

Fitting Instructions Part Number C40 Holden RG Colorado Dual Cab 2012+

Check contents of kit before commencing fitment and report any discrepancies

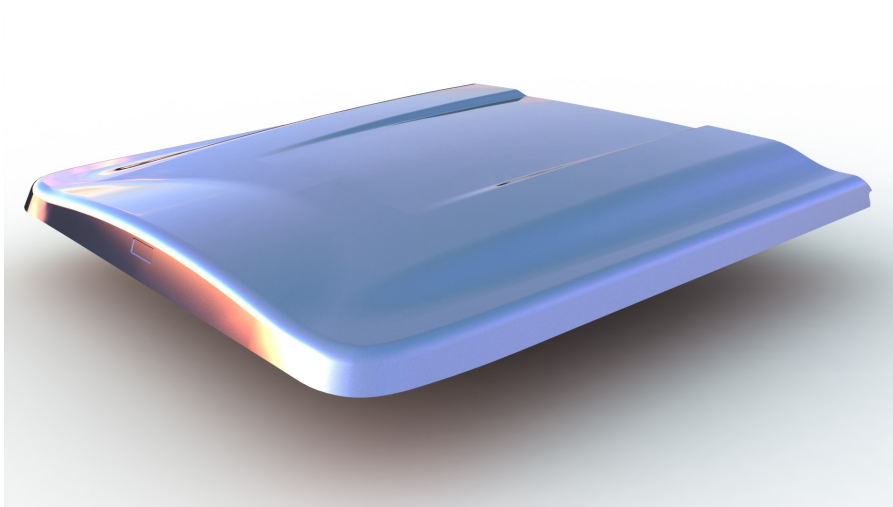

*Image example shown only

IMPORTANT	<ul style="list-style-type: none"> • Do not stand/sit or rest heavy objects on Tonneau Cover • Humans or animals are not to be under the closed Tonneau at any given time • Securely lock tonneau Cover before operating vehicle • Tonneau Cover is not dust or water tight • Do not carry open volatile chemicals with Tonneau Cover installed • If contact with volatile chemicals occur, clean Tonneau with mild detergent and water solution 			
Care Instructions	<ul style="list-style-type: none"> • Read Instructions fully before commencing installation. • Clean Tonneau Cover with a mild detergent and water solution • Do not use abrasive cleaners or solvents • Refer to manufactures instructions applicable to power drill. • Protect Tub floor against scratches during installation process. 			
Maintenance	If lubrication of the locks or hinges is required use only Graphite Powder. DO NOT use any other lubricants or oils.			
Tools Required	<table style="width: 100%; border: none;"> <tr> <td style="vertical-align: top;"> <ul style="list-style-type: none"> • Pen / Marker • Centre Punch • Drill & Drill bits • Phillips head screwdriver • Caulking Gun • Silicon - Non Acetic </td> <td style="vertical-align: top;"> <ul style="list-style-type: none"> • Die Grinder & multi tool • Masking Tape • Scissors & Knife • Ruler • Spanner & Socket • Tape measure </td> <td style="vertical-align: top;"> <ul style="list-style-type: none"> • Soapy water solution • Allen Key set (Metric) </td> </tr> </table>	<ul style="list-style-type: none"> • Pen / Marker • Centre Punch • Drill & Drill bits • Phillips head screwdriver • Caulking Gun • Silicon - Non Acetic 	<ul style="list-style-type: none"> • Die Grinder & multi tool • Masking Tape • Scissors & Knife • Ruler • Spanner & Socket • Tape measure 	<ul style="list-style-type: none"> • Soapy water solution • Allen Key set (Metric)
<ul style="list-style-type: none"> • Pen / Marker • Centre Punch • Drill & Drill bits • Phillips head screwdriver • Caulking Gun • Silicon - Non Acetic 	<ul style="list-style-type: none"> • Die Grinder & multi tool • Masking Tape • Scissors & Knife • Ruler • Spanner & Socket • Tape measure 	<ul style="list-style-type: none"> • Soapy water solution • Allen Key set (Metric) 		

PARTS CHECK SHEET

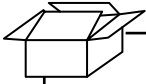

PARTS IN MAIN CARTON

1

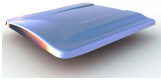

Tonneau Cover
Qty - 1

4



Lock Keys
(Attached to
Tonneau rotary
latch) Qty - 2

5

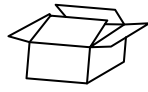

Fitting Kit
Qty - 1

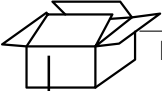

PARTS IN FITTING KIT

1178



Lid HInge
Qty - 2

1177



Hinge Bracket
Qty - 2

1177

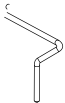

Hinge Pin
Qty - 2

S700-220



Gas Strut
Qty - 2

1040



Strut body mount
Qty - 2

UB



Striker U-Bolt
Qty - 2

1189

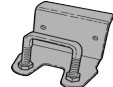

Striker
Bracket
Qty - 2

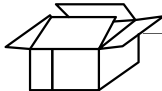

LID NUTS AND BOLTS

25



M8x25 ALAN
Head Bolt
Qty - 8

24



M8 3mm thick
Flat Washer
Qty - 8

19



Self drilling screws
Qty - 12

23



M8
Hex Nut
Qty - 8

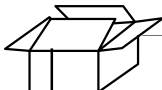

OTHER

42



Alan key
Qty - 1



Alcohol wipe
Qty - 1



Fitting
Instruction
Qty - 1

Installation Steps Flow Chart

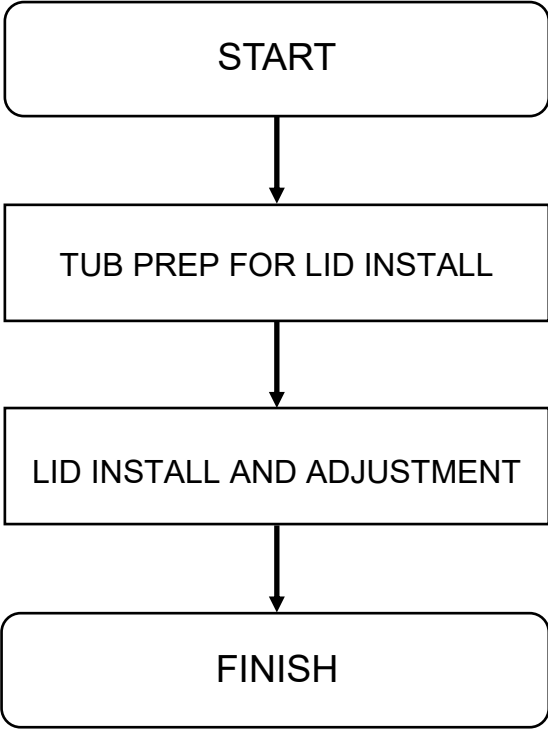

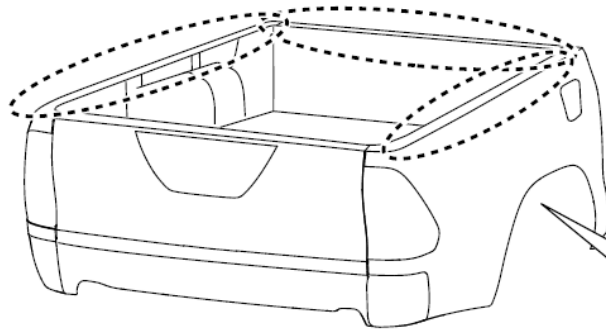

Thoroughly clean installation areas.

Important:

Instructions are for Utes with an UNDER-RAIL tubliner. If you have an OVER-RAIL tubliner you must trim the top off.

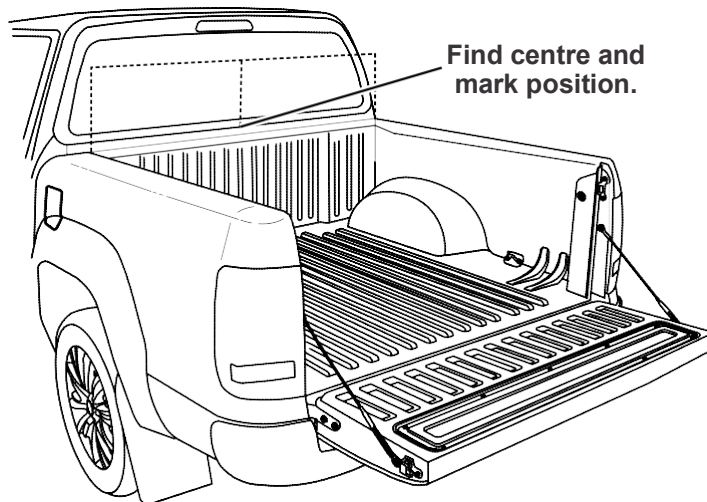

Find centre and
mark position.

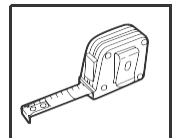

Hinge mounts:

Align the hinge mounts along front of tray, ensuring the hinges are properly positioned from centre of tub **460 mm** to centre of hinge mount either side along the inside of the front of tub. Attach the hinges using self-drilling screws (supplied) through holes pre-drilled into the hinges. Apply clear or black silicone to any gaps and between the hinges and the vehicle to prevent water entry.

Measure distance from centre on both sides and mark.

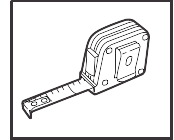
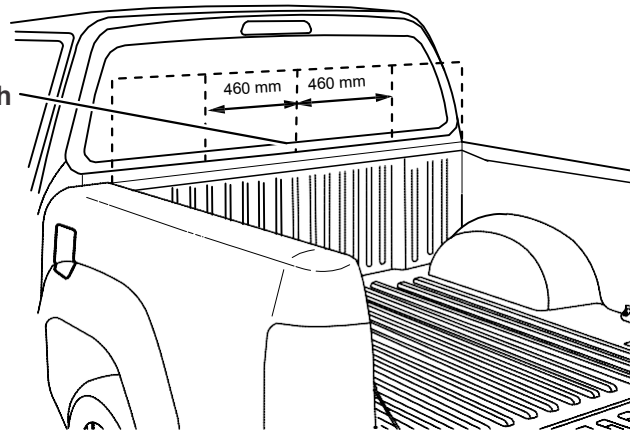

Measure and mark the positions as indicated above from the centre of the bed for placement of the bottom hinges.
WARNING: RECHECK DIMENSIONS TO ENSURE CORRECT MEASUREMENT

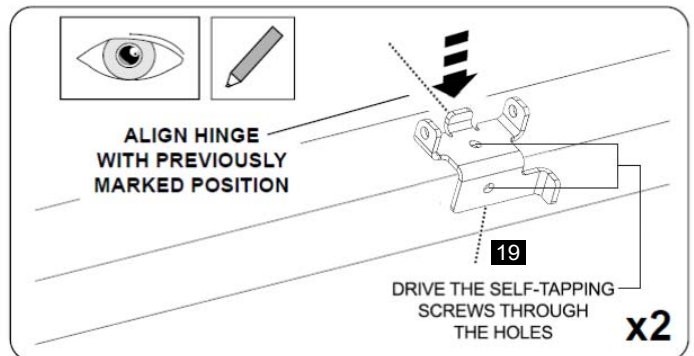
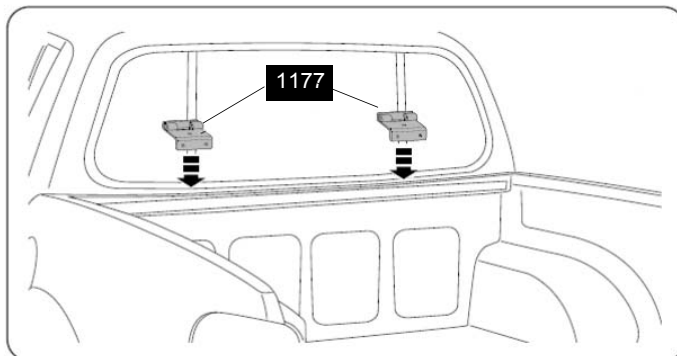

Drive the self-tapping screws through the holes in the top and the base of the hinge plate into the tub. Tighten to 3Nm.

Gas Struts:

Measure from the front rail inside of tub, measure along top edge of tray **700 mm** (windscreen end) then down **20mm** and mark the screws position for the gas strut bracket. Position the gas strut bracket accordingly, mark two mounting holes and centre. Refer to Fig. 1 and Fig. 2

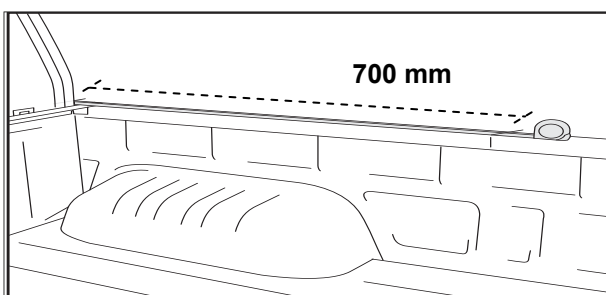

Fig.1 - Gas strut bracket location

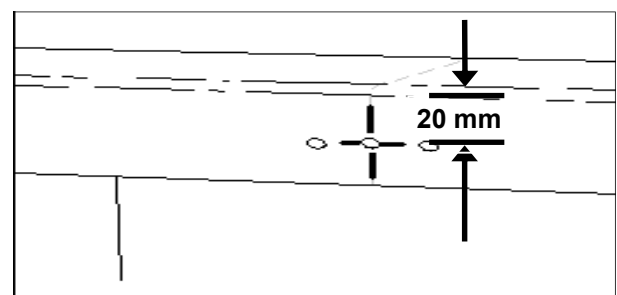

Fig.2 - Gas strut bracket location

Using a **2 mm** diameter drill bit set to **5 mm** drill stop. Drill two pilot holes. Attach small gas strut bracket using self drilling screws provided. Repeat process on other side of tray. **Refer to Fig. 2 and Fig.3**

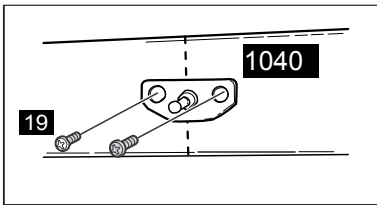

Fig.3 - Gas strut bracket fitment

Attach small shaft end of gas strut onto gas strut brackets, by clicking them in place. **Refer to Fig.4 with regard to gas strut orientation.**

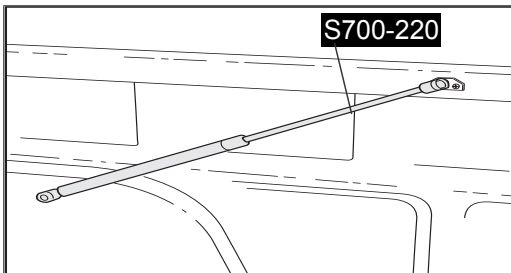
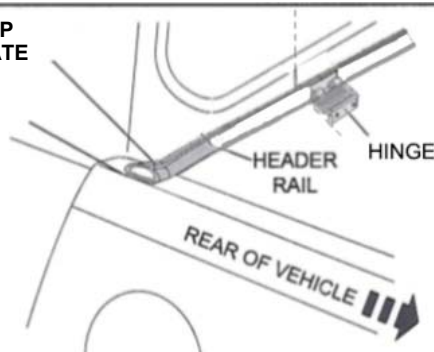

Fig.4 - Gas strut orientation

**NOTE: SEALING LIP
MUST FACE TAILGATE**

**START EXTRUSION
AT EDGE OF SIDERAIL**



Extrusion to run behind hinge and finish to the same spot on the other side.

You may cut off the desired excess at the end of your installation

Clean header rail (where extrusion will sit) with alcohol wipes provided and wipe away residue with a dry clean cloth. Place the extrusion tape seal along the top of the header rail with the sealing lip facing towards the tailgate. Start the extrusion at the edge of the side rail. **IMPORTANT:** Position extrusion as close to the header rail rear radius. Rub down firmly to ensure maximum adhesion.

Important:
DO NOT over tighten screws. Recommended tightening torque is 1- 3 Nm

Attach lid hinges to tub hinges
by aligning and pushing pin
through.
Click pin down into hinge
locking tab

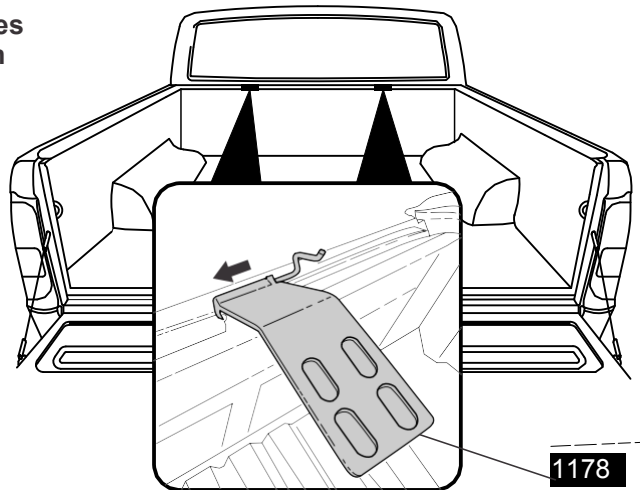

Fit the lid and adjust so it is even on
both sides and forward as far as
possible while staying level.

Note: When gas struts are fitted, lid
will be pulled back slightly.

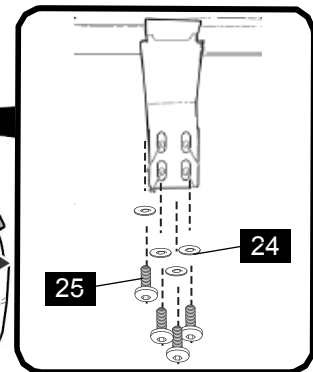
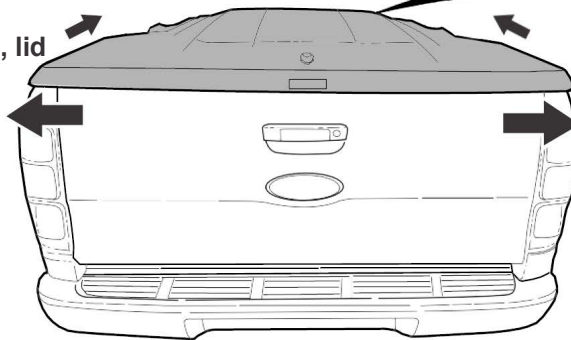

When lid is aligned correctly,
secure the catch hinge to the
lid using 4 M8 Thick
Washers and M8 Bolts

Important:
Ensure tongues are fully inserted into the hinge slots with hinge pin securely in place.

With the Hard Tonneau Cover opened, attach the cylinder end of each gas strut onto the mounting brackets attached to the Hard Tonneau Cover by clicking into place
Refer to Fig. 9

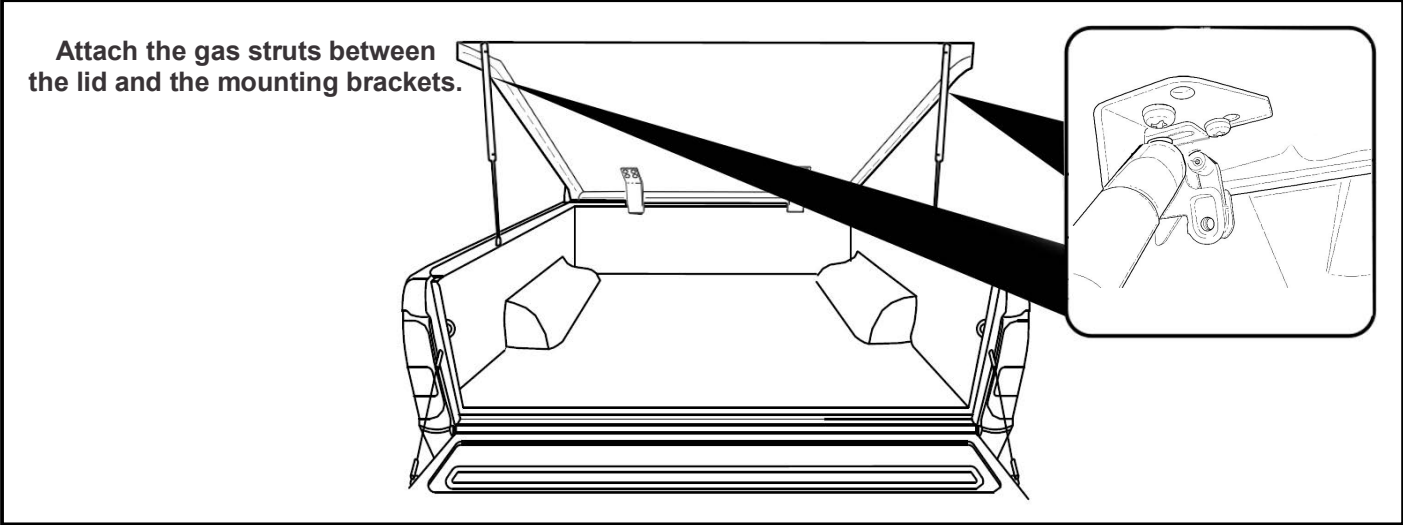
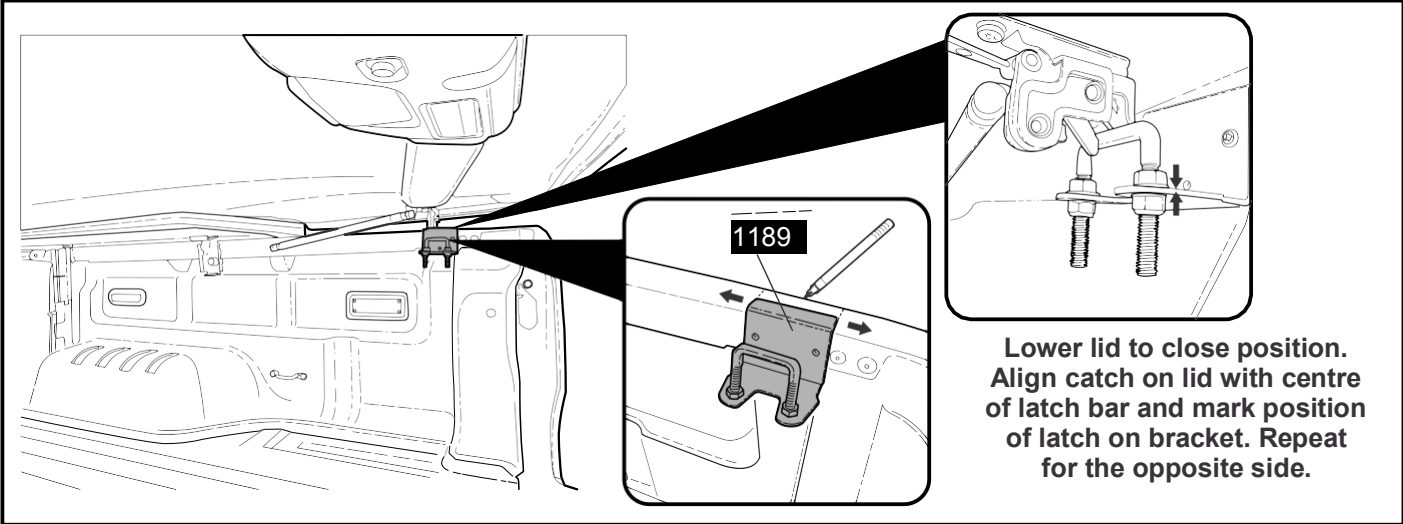

Fig. 9 - Attach gas strut



Important:

If you have purchased a Central Locking Ute Lid please ignore the next page concerning Lock Bracket Installation and Lock Bracket adjustment.

**Fasten latch bracket
in place with self-tapping
screws.**

**Repeat for the opposite
side.**

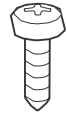
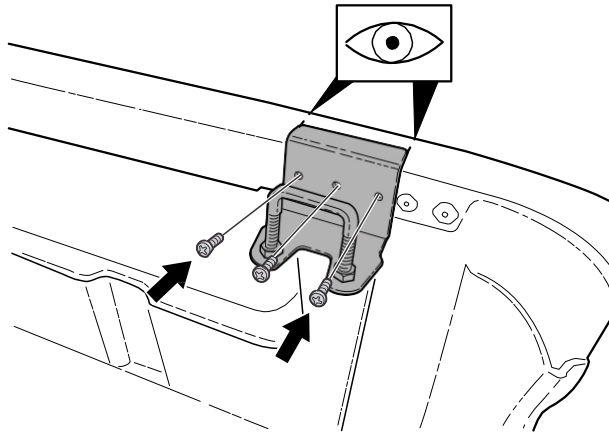

**Part No: 19
Self Tapping
Screws**

Loosen 2 screws and slide catch to align correctly with latch bar. Tighten screws to secure in place.

Adjust nuts on latch bar to alter height of bar to suit.

Repeat for the opposite side.

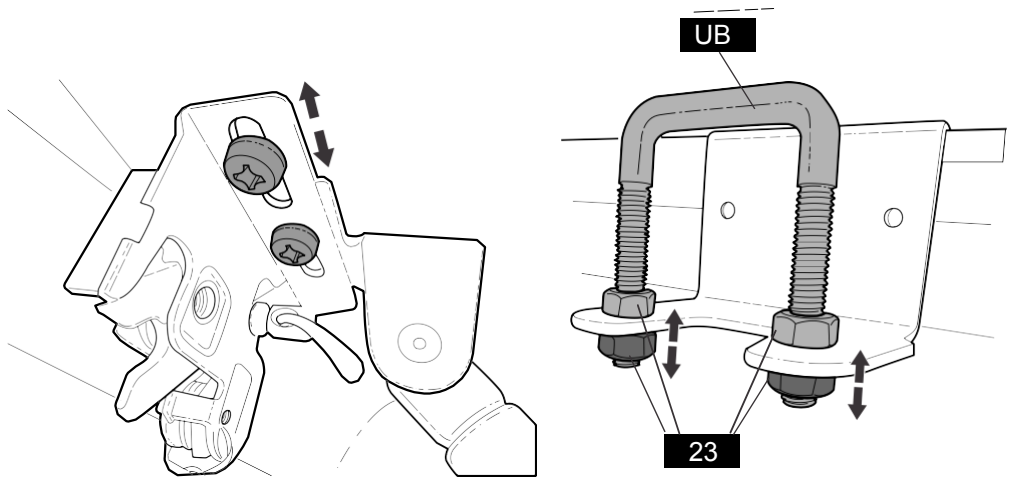

Use an Allen key to loosen the hex key screw on the catch and tension cable so it is tight but doesn't move the catch at all, then re-tighten the hex key screw.

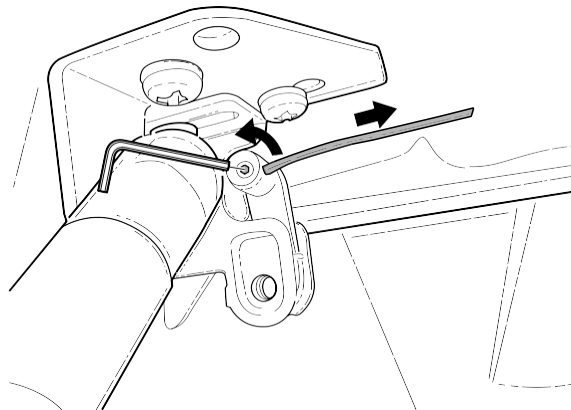

Cut off excess cable making sure to leave 20mm from locking allen key bolt.

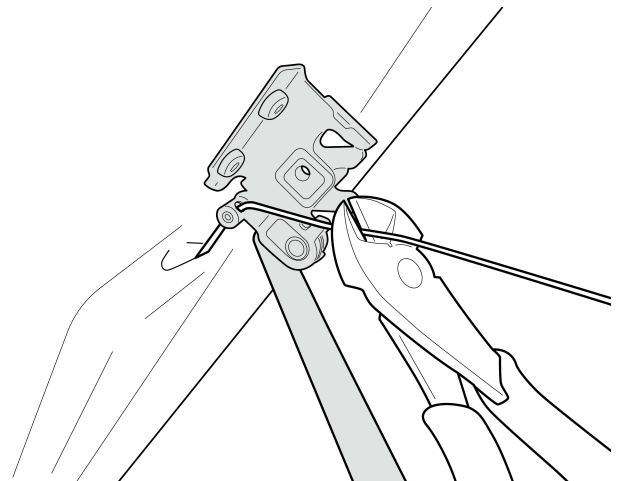

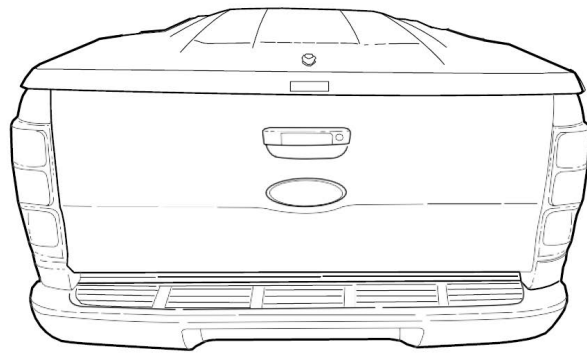

REPLACEMENT OF TONNEAU COVER

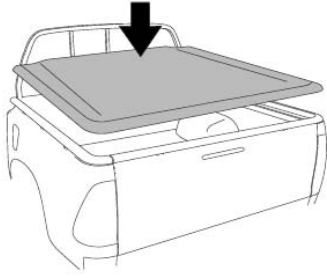

FIGURE 4

NOTE: 2 people are required to lift and fit the tonneau cover onto the vehicle.

1. Fit tonneau cover (2) and secure hinges with hinge pins (1). Refer to figure 5.

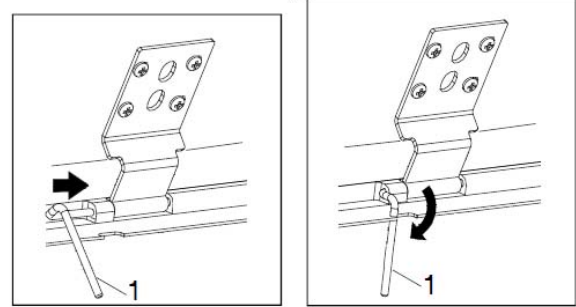
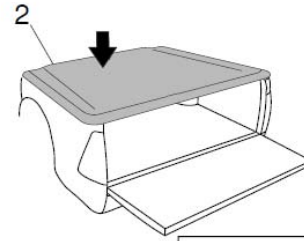

FIGURE 5

2. Attach gas struts (2) by clipping into place. Ensure narrow end (1) mounts to the vehicle. Refer to figure 6.

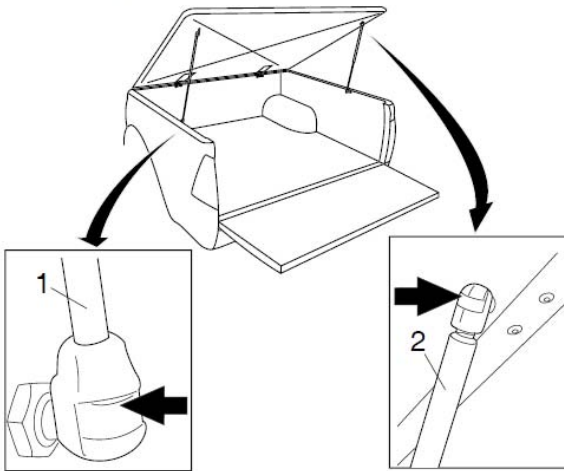

FIGURE 6

Paint care instructions:

Your new painted Hard Tonneau Cover has been covered with a plastic film to protect the paint from damage. It will require cleaning and possibly light polishing after the protective film has been removed. Use polish as per new paint on a new vehicle. Wash Hard Tonneau Cover using water and normal carwash detergent and polish with an automotive polish.

NOTE: Please ensure Lid is kept locked at all times when not being used, for both safety and longevity.

Having trouble? Call your Supplier.

REMOVAL OF TONNEAU COVER

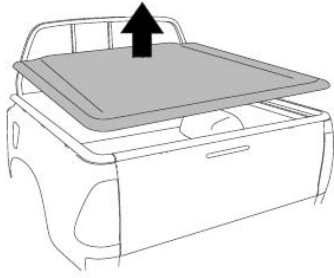

FIGURE 1

1. Open tonneau cover, Detach gas strut (1) by inserting a small screwdriver and adjusting the spring clip (2) on the gas strut (1). Refer to figure 2.
NOTE: Do not remove the spring clip. only a small amount of levering is required to detach.

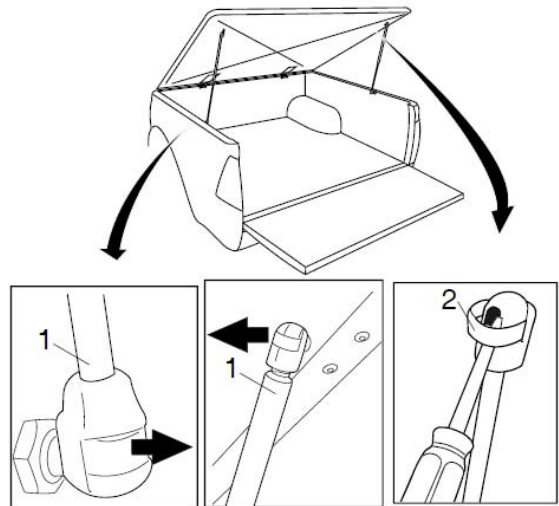

FIGURE 2

NOTE: 2 people are required to lift and remove the tonneau cover from the vehicle.

2. Remove hinge pins (1) and remove tonneau cover (2). Refer to figure 3.

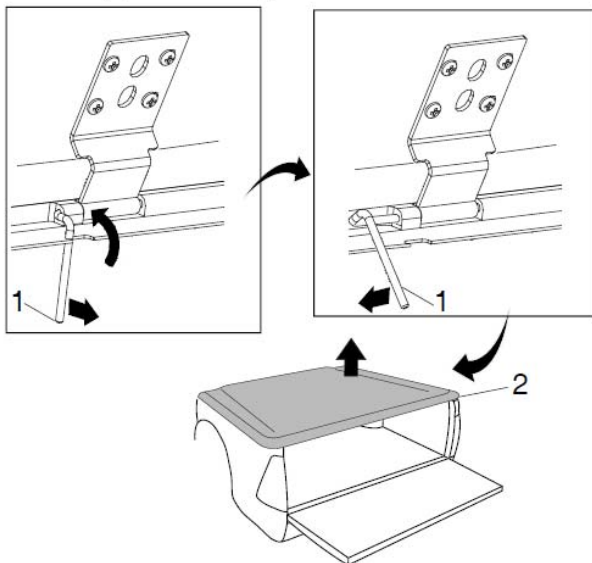

FIGURE 3

C40P

Holden RG Colorado Dual Cab

PREMIUM LID

C40P	LID		
PART DISCIPTION	PART NUMBER	QUANTITY/LENGTH	CHECK
LID FRONT HINGES	1178	2	
LID TUB MOUNTS WITH PINS	1177	2	
GAS STRUTS	S700-220	2	
STRUT BODY MOUNTS	1040	2	
M8 U BOLT	UB	2	
LOCK STRICKER BRACKETS	1189	2	
LID NUTS AND BOLTS			
M8 BOLTS	25	8	
M8 WASHER (3MM THICK)	24	8	
SELF DRILL SCREWS	19	18	
M8 NUTS	23	8	
OTHER			
Allen Key	42	1	
D MOLD	LID-SEAL-04	1530 MM	
ALCOHOL WIPE		1	
FITTING INSTRUCTION MANUAL		1	