



WWW.HSPUTELIDS.COM

Part No: HJ4R

Fitting Time: 180 minutes

ROLL-R-COVER

To suit Toyota Hilux Revo Dual Cab J-Deck

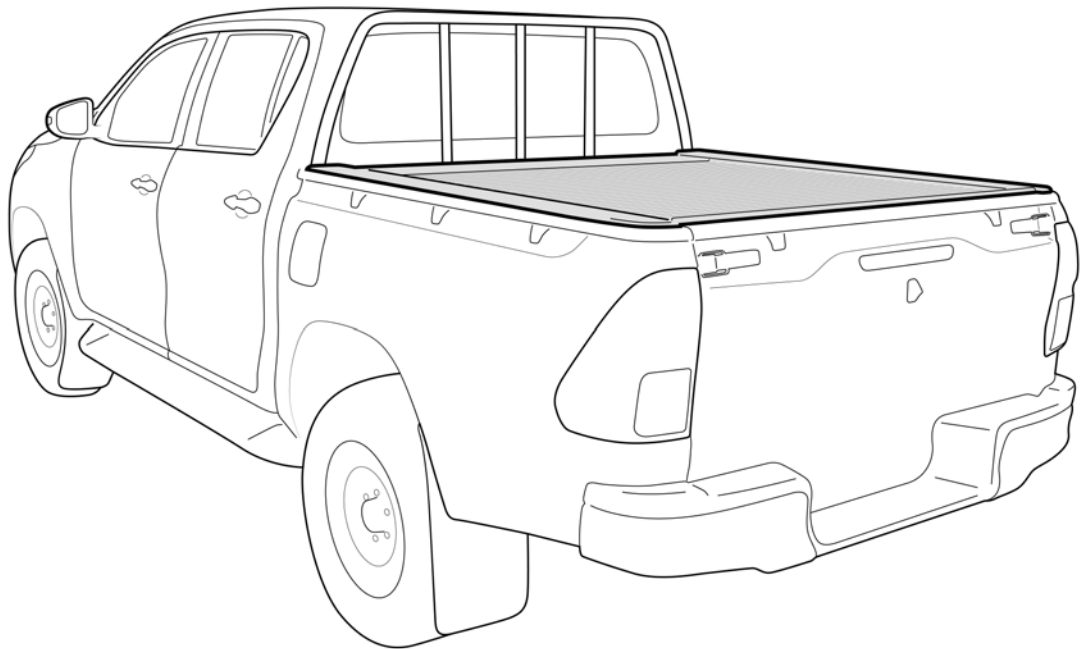

Roll-R-Cover

Fitting Instructions

– General Notes

- Read through the fitting instructions before installation of accessory.
- Always install the Roll R Cover Wiring Kit following the workshop manual and fitting instructions provided. Failure to do so may cause damage to the vehicle or the accessory.
- Ensure all recyclable components and packaging are discarded and recycled following local recycling regulations.
- It is always recommended that the Roll R Cover Wiring Kit is fitted by a qualified automotive technician.
- Safely store and protect any removed vehicle components.

– Safety Notes

- Check that all work practices comply with safety standards.
- Please wear appropriate clothing and use safety equipment.



– Fitting Time



180 minutes

– Parts Supplied

HJ4R	DUAL CAB TOYOTA HILUX SR5 (J DECK) - ROLL R COVER		
PART DESCRIPTION	PART NUMBER	QUANTITY/LENGTH	CHECK
HJ4R FITTING INSTRUCTIONS	372*	1	
LUBRICANT PUMP SPRAY	47*	1	
REMOTE	215*	2	
PRIMER STICK	44*	1	
CABLE TIE 4.8X300MM	217*	10	
ROLL R LOOM	216*	1	
H4JR CANISTER AND CURTAIN	272*	1	
H4JR RAIL RIGHTHAND	313*	1	
H4JR RAIL LEFTHAND	314*	1	
SELF TAPPER WAFER SCREWS	48*	6	
HJ4R FRONT BAR ASSEMBLY	150*	1	
HOSE 600MM	11*	4	
COMPLETE CANISTER COVER	400	1	
OPERATION LEAFLET	66	1	
MAINTENANCE LEAFLET	67	1	
BLACK PUTTY	3*	8	

**The following steps are for vehicles with bed liners.
If there are no bed liners installed move to Step 5**

– Step 1

Trim front of bed liner by 180mm from the top of the ute bed as shown.

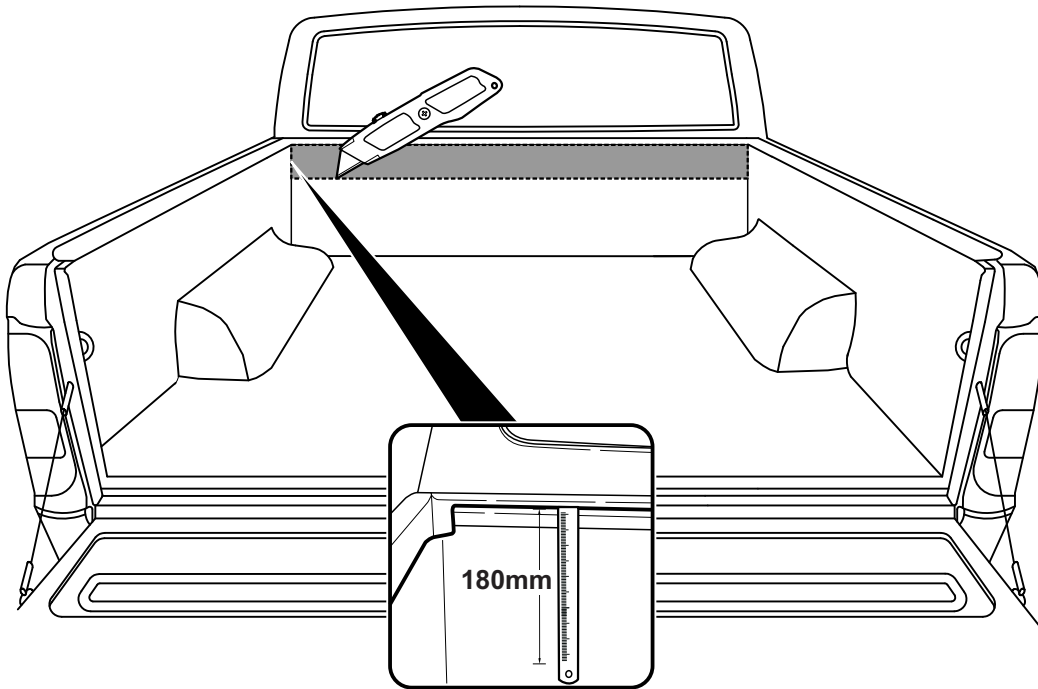

– Step 2

Cut a 20mm split for bed liner to flex.

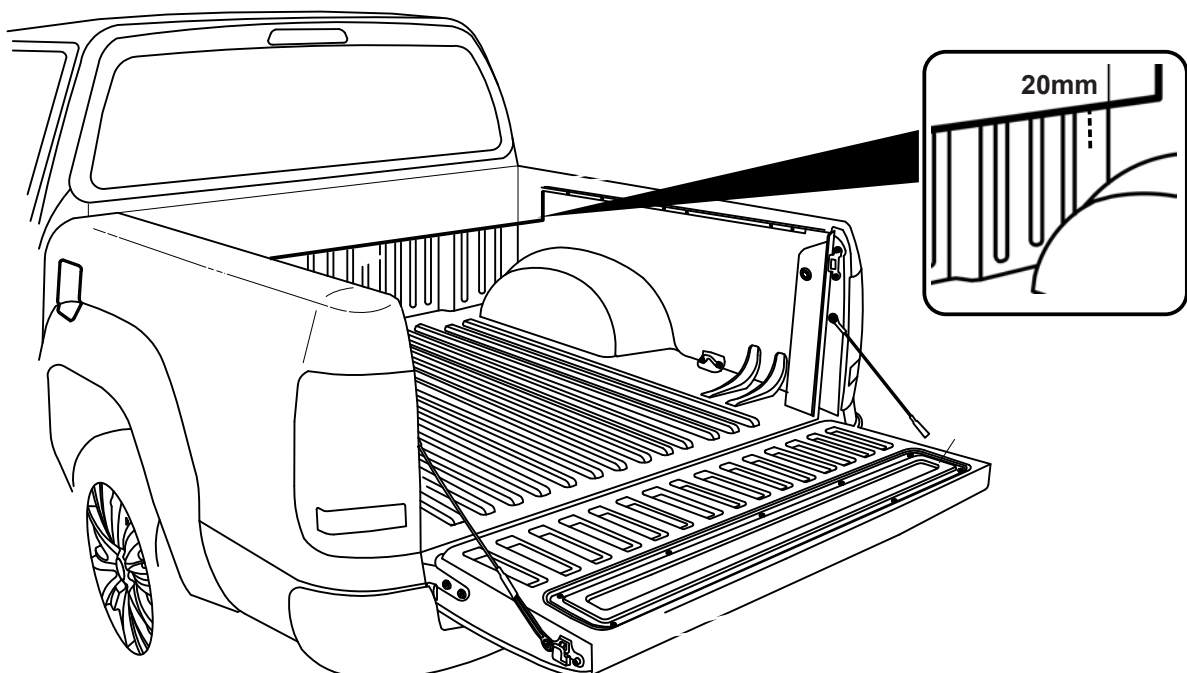

— Step 3

Measure 60mm from top of tub and trim liner.

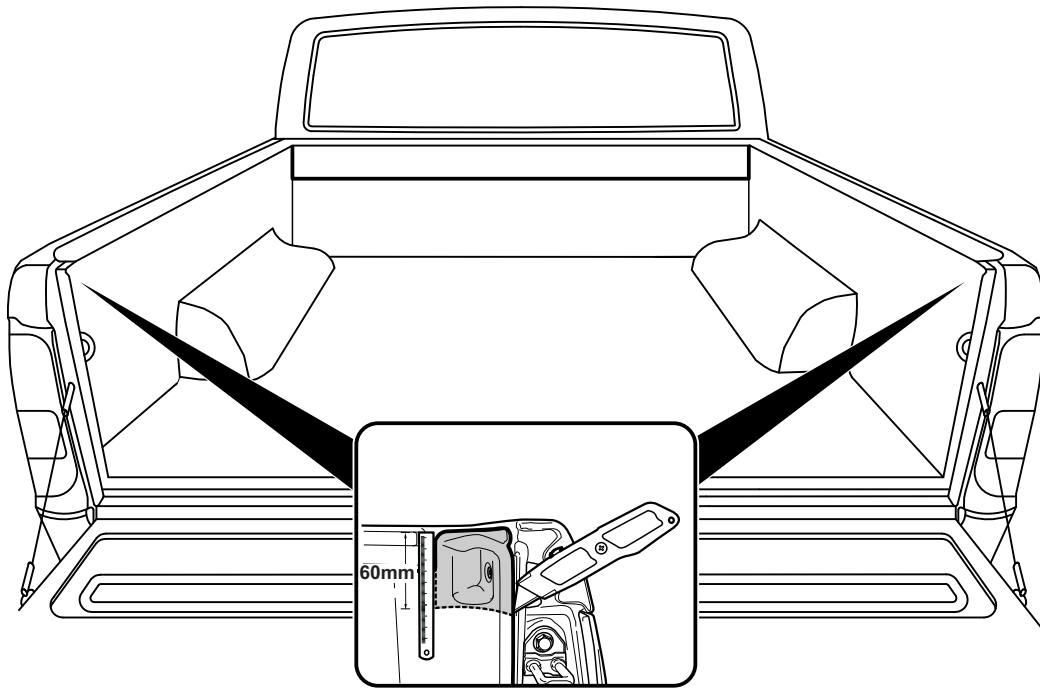

— Step 4

Measure 20mm down from top of tailgate and trim tailgate liner.

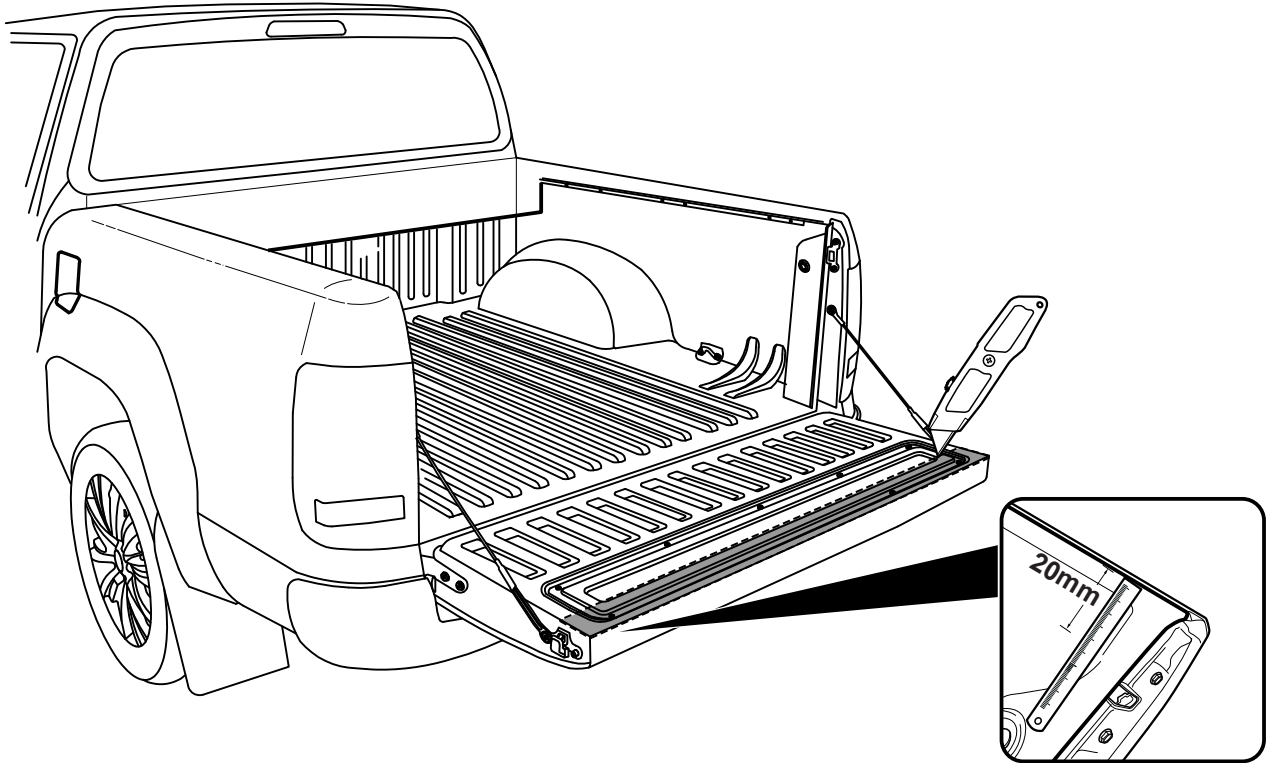

– Step 5

Roll-R-Cover preparation steps

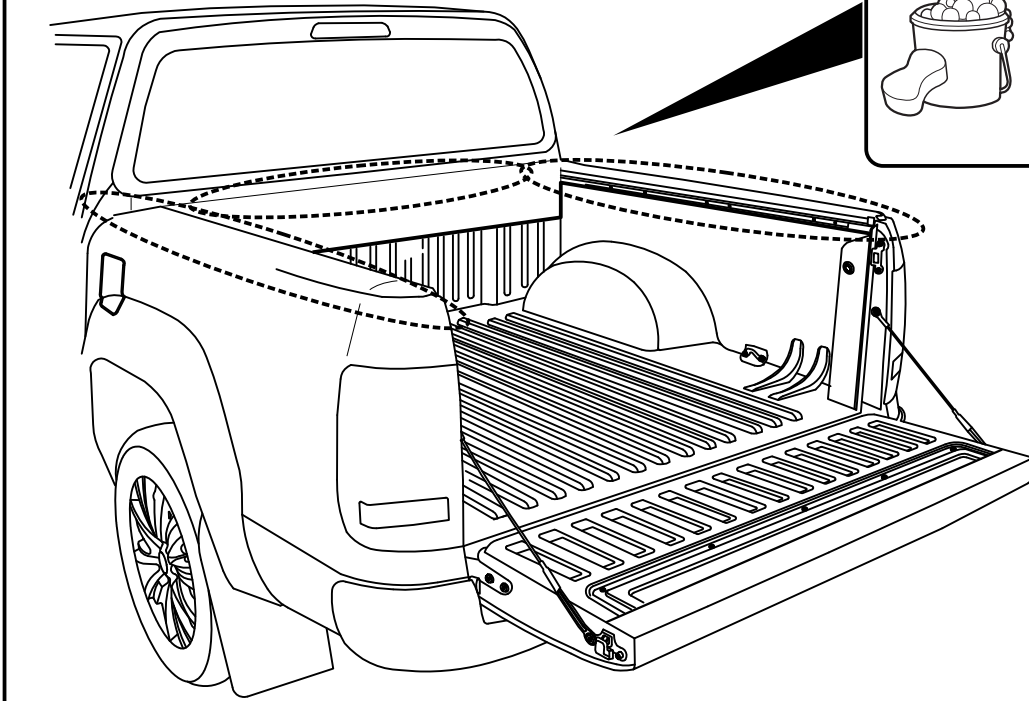

– Step 6

Carefully unpack the box.

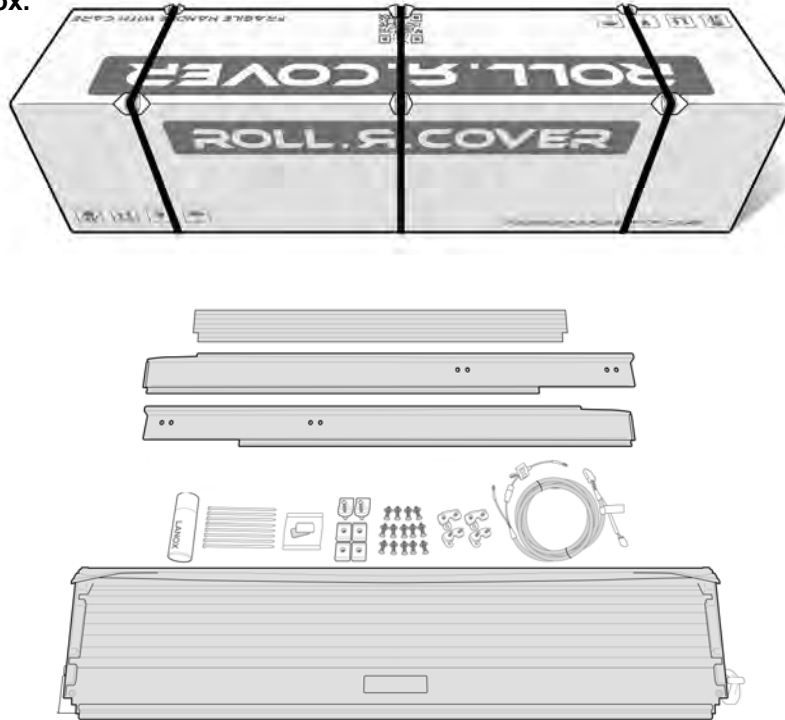

– Step 7

Wiring Harness steps

1 Drill through passenger side front panel to feed wiring loom.

Note- when drilling, check for obstructions and after drilling apply rust inhibitor to the hole.

2

3

216

Run the wiring from the front corner cavity to the battery over the chassis rail. Making sure to keep away from hot obstructions and cable tie every 400mm.

– Step 8

Remove M8 Bolt & M8 Spring Washer

270

305/306 LHS & RHS

M8

M8

Important
Ensure the black tar is not removed with the film.

— Step 9 —

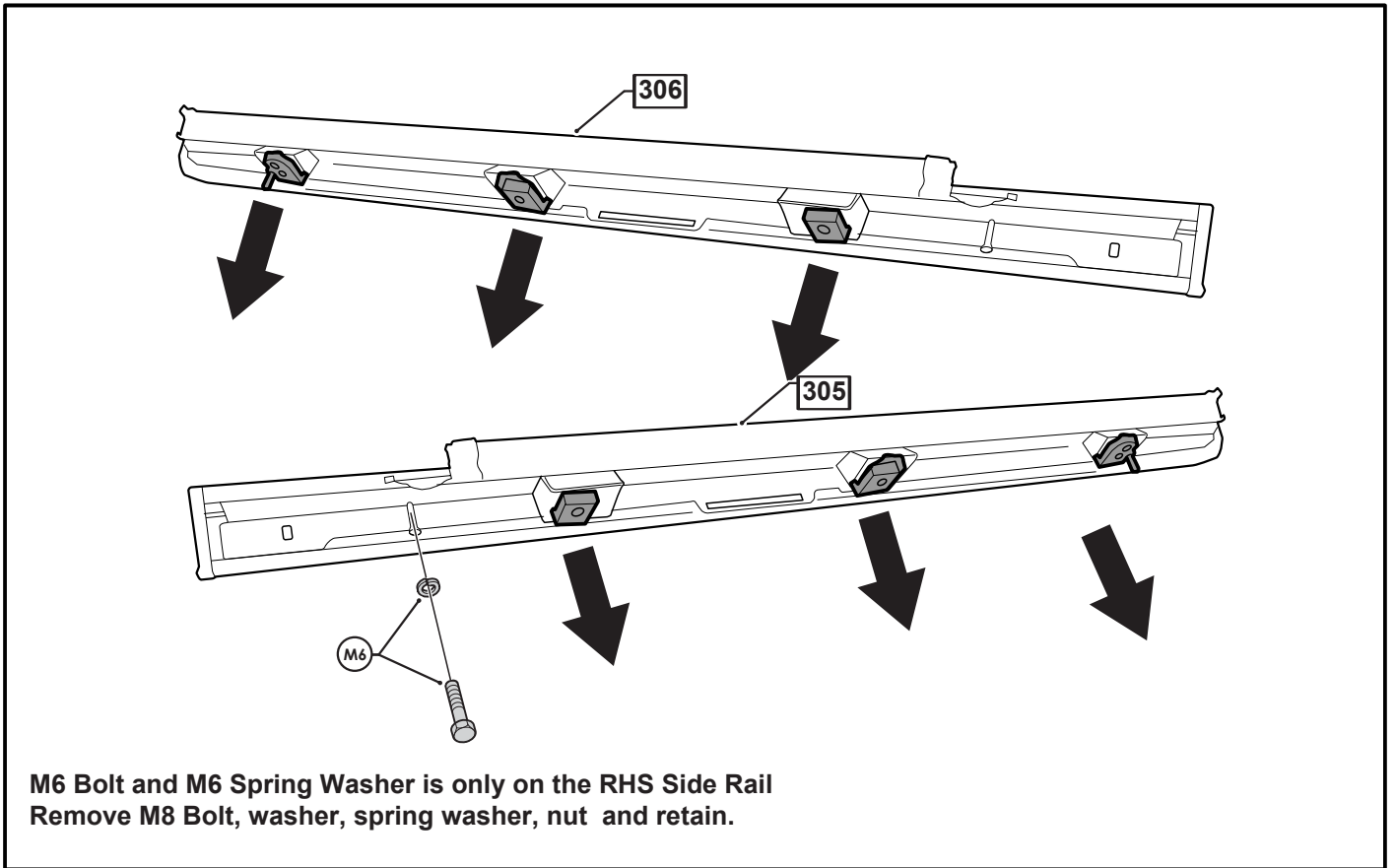

— Step 10 —

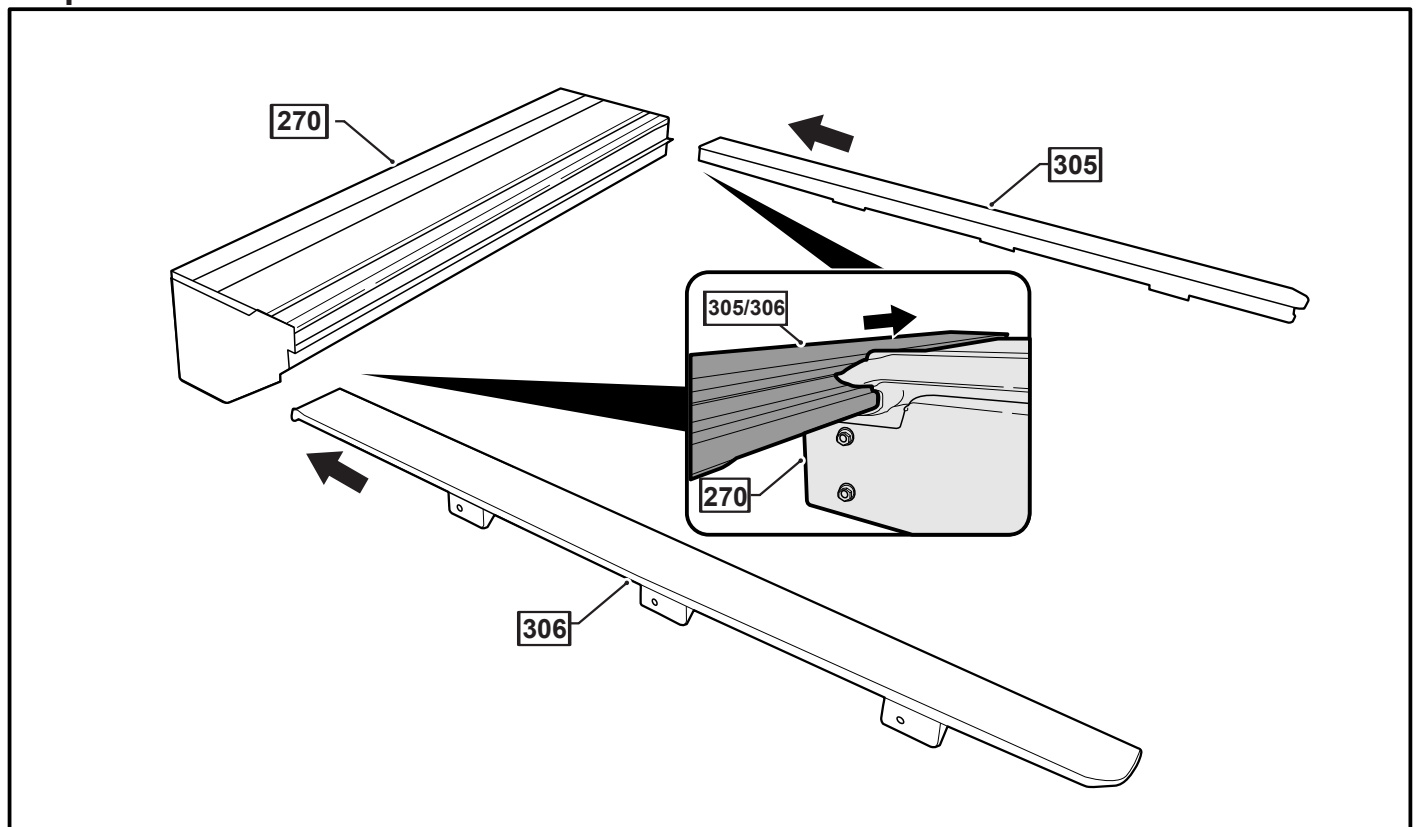

– Step 11

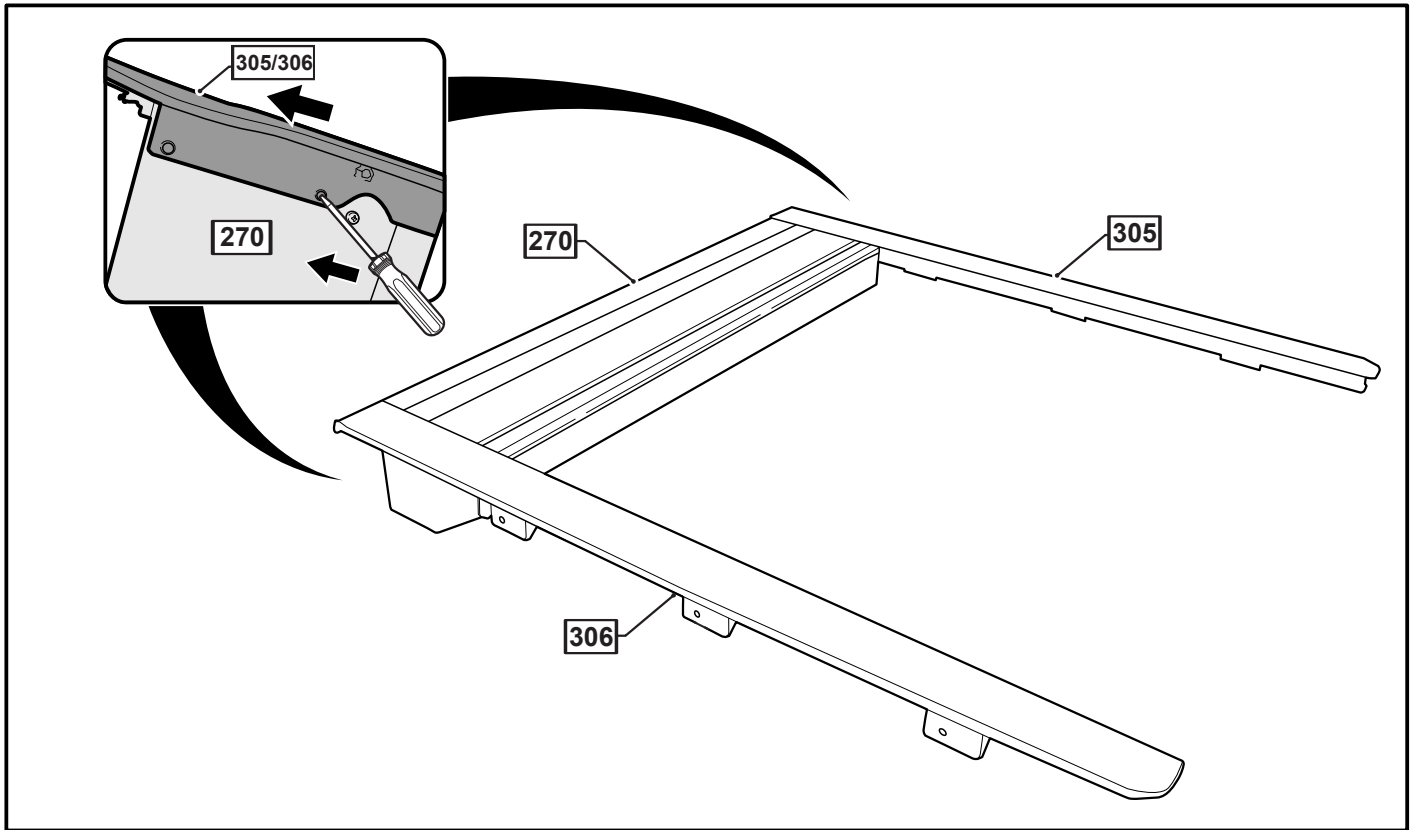

– Step 12

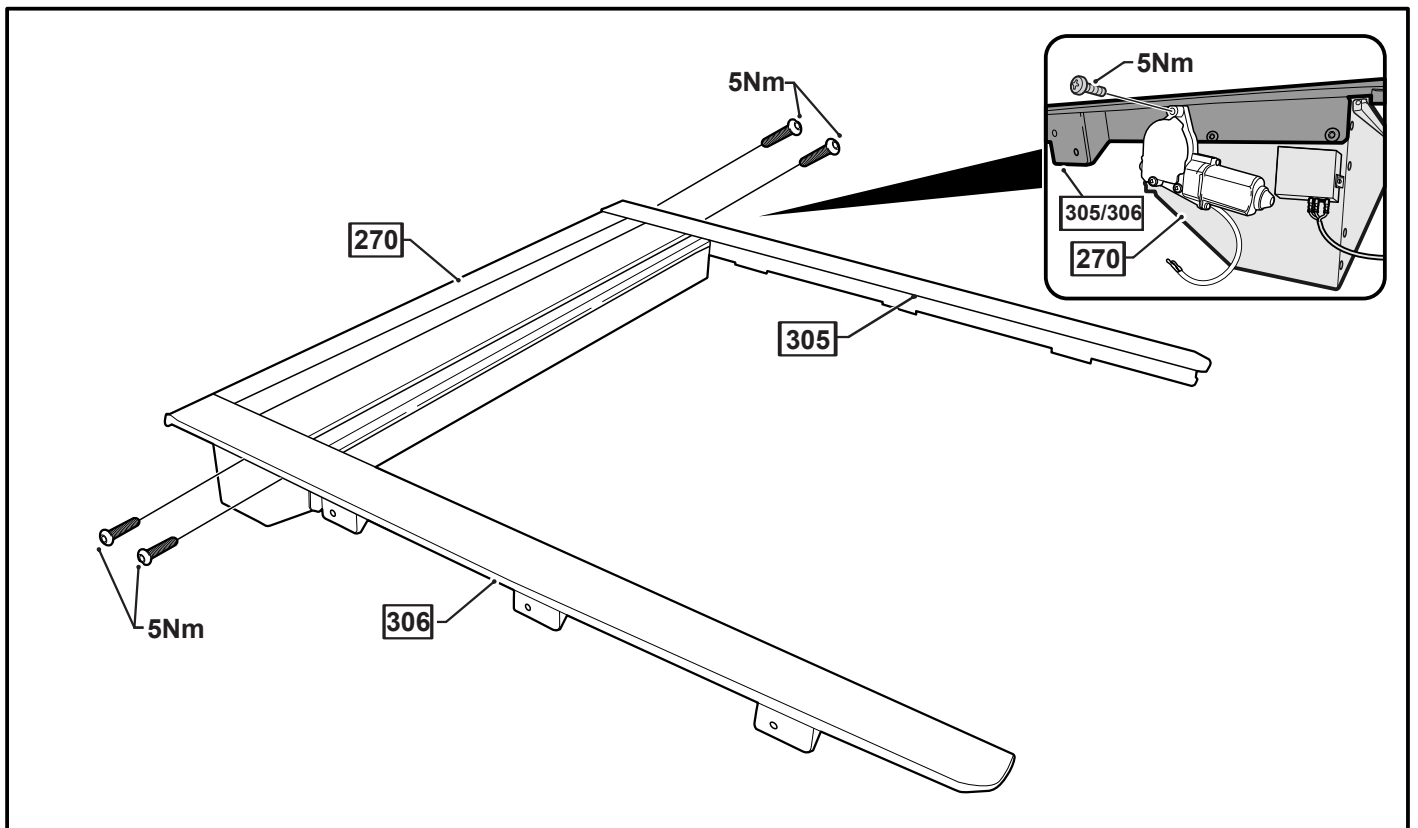

– Step 13

Apply tar sealant to the gap under water channel.

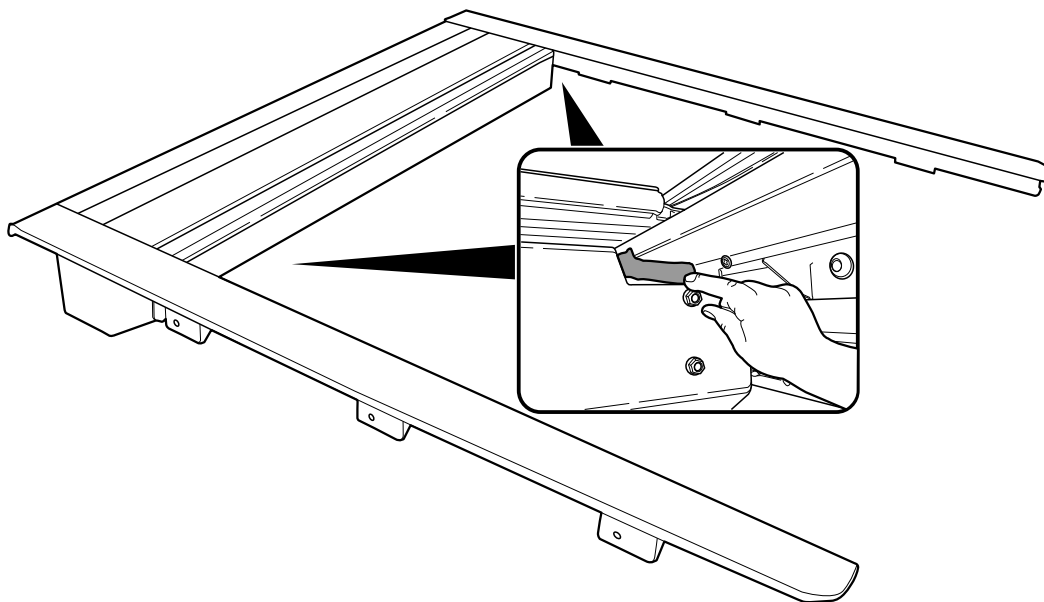

– Step 14

Apply tar sealant to both sides of the canister as shown (where accessible).

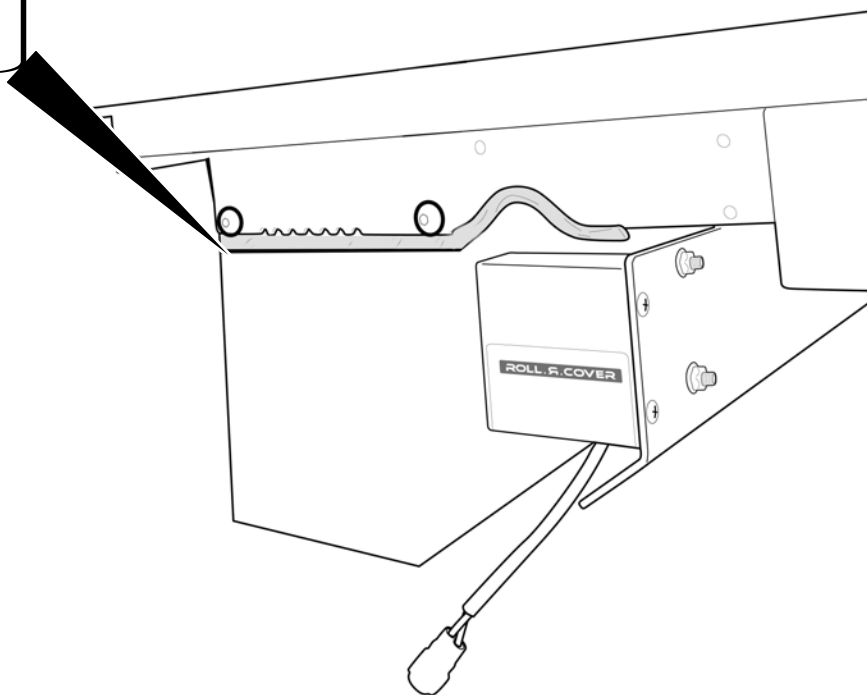

– Step 15

Align the front bar assembly along the front of the tray ensuring that the bar is centered. Attach FBA using the self-drilling screws [supplied] through the holes pre-drilled in the front bar making sure the top is level with the side of the tub.

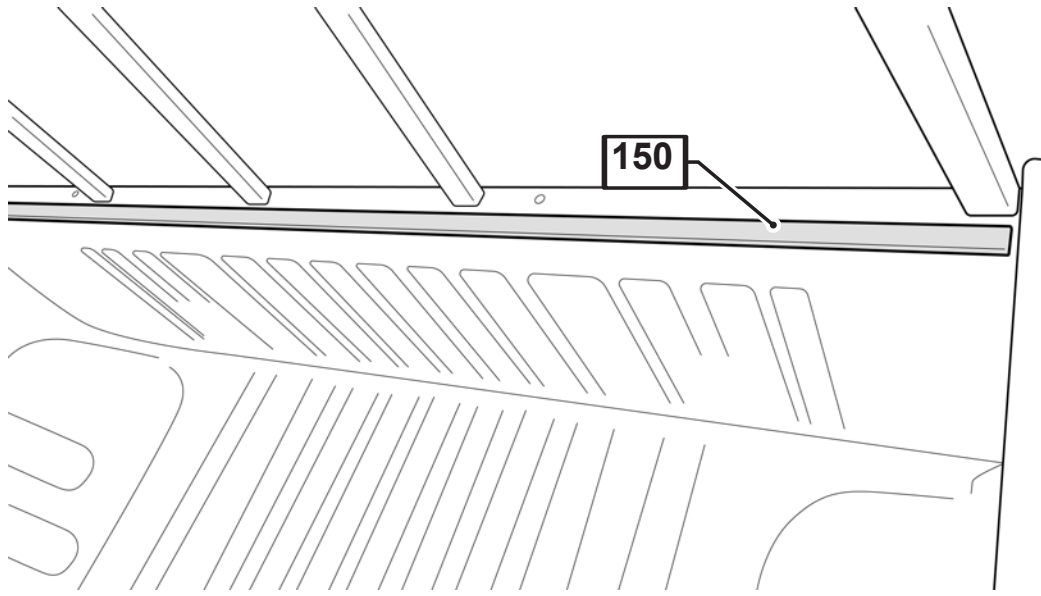

– Step 16

Place Roll-R-Cover on the tub

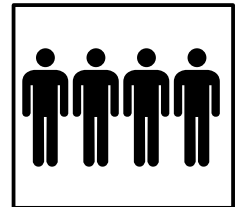
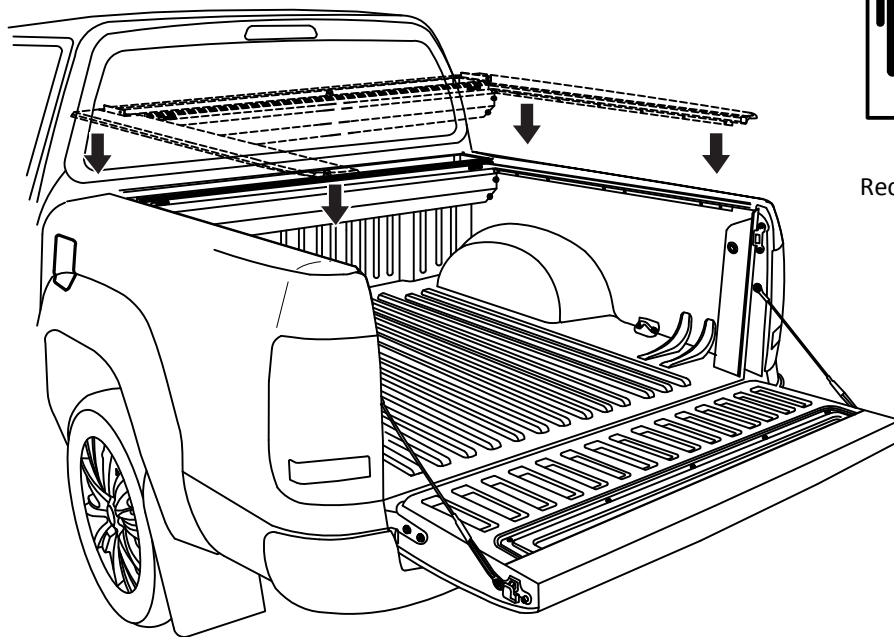

4 People
Recommended for lift

– **Step 17**

Locate side rail tabs that are resting against the side of tub, mark through the per-drilled holes on the tabs. Repeat for all 6 tabs.

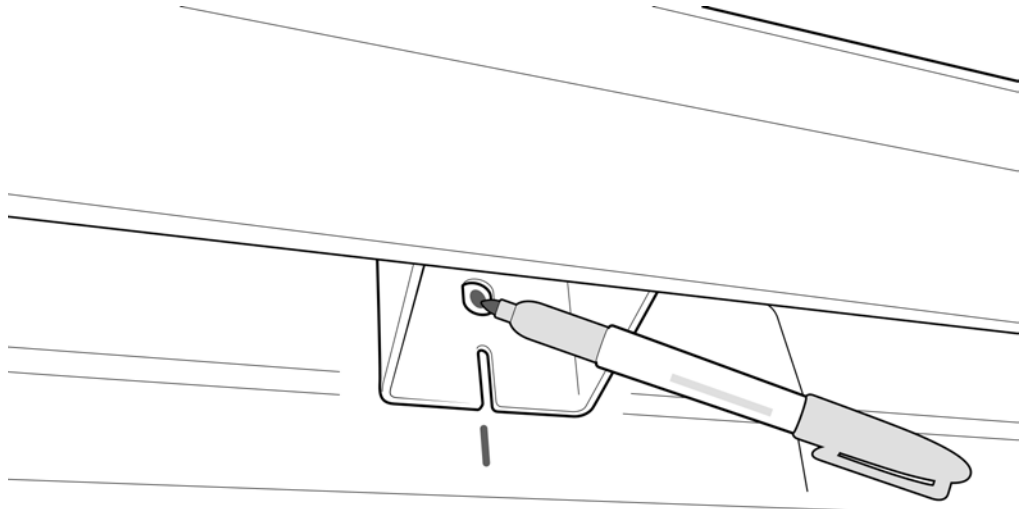

– **Step 18**

Remove Roll R Cover from the tub.

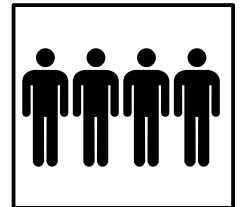
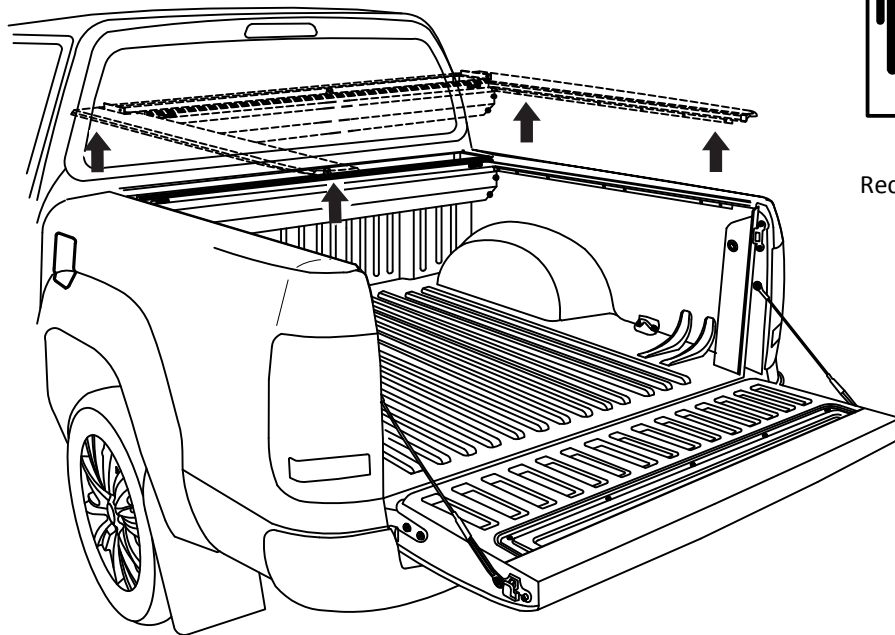

4 People
Recommended for lift

– Step 19

Drill through pre-marked hole using 9mm drill bit.

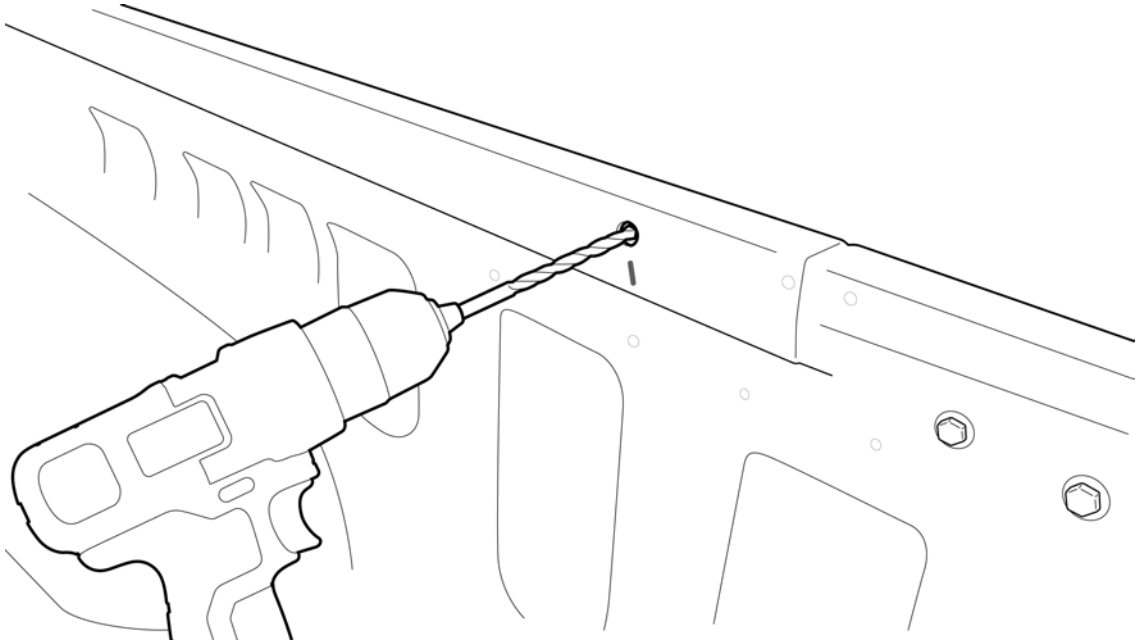

– Step 20

Seal any exposed gaps.

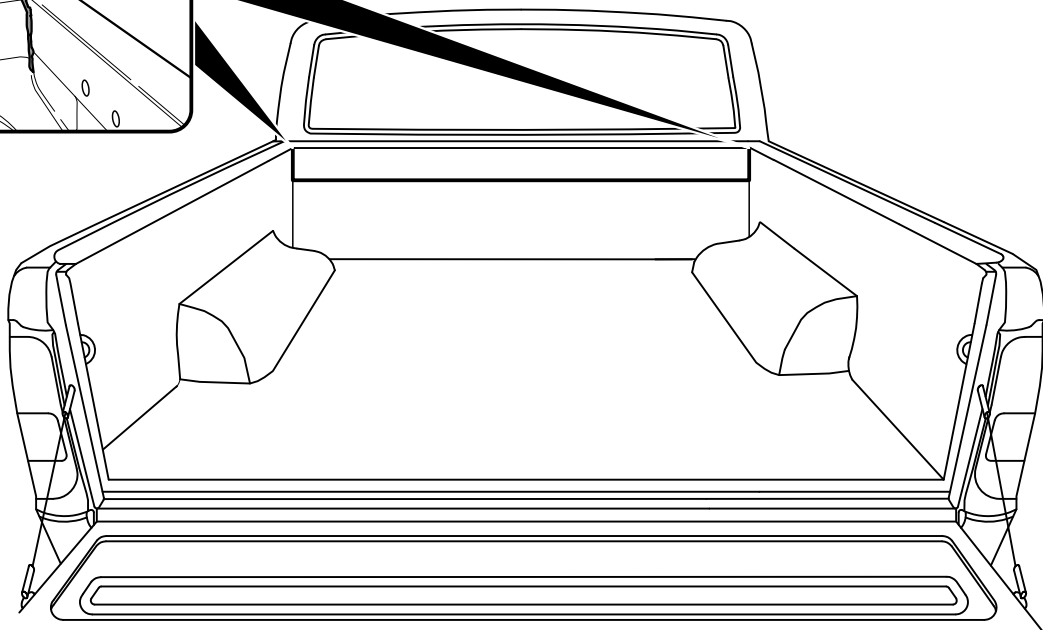
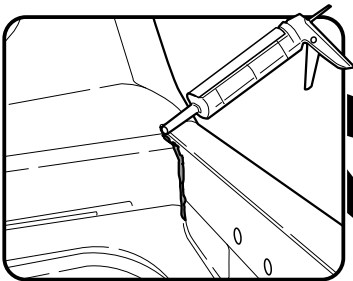

– Step 21

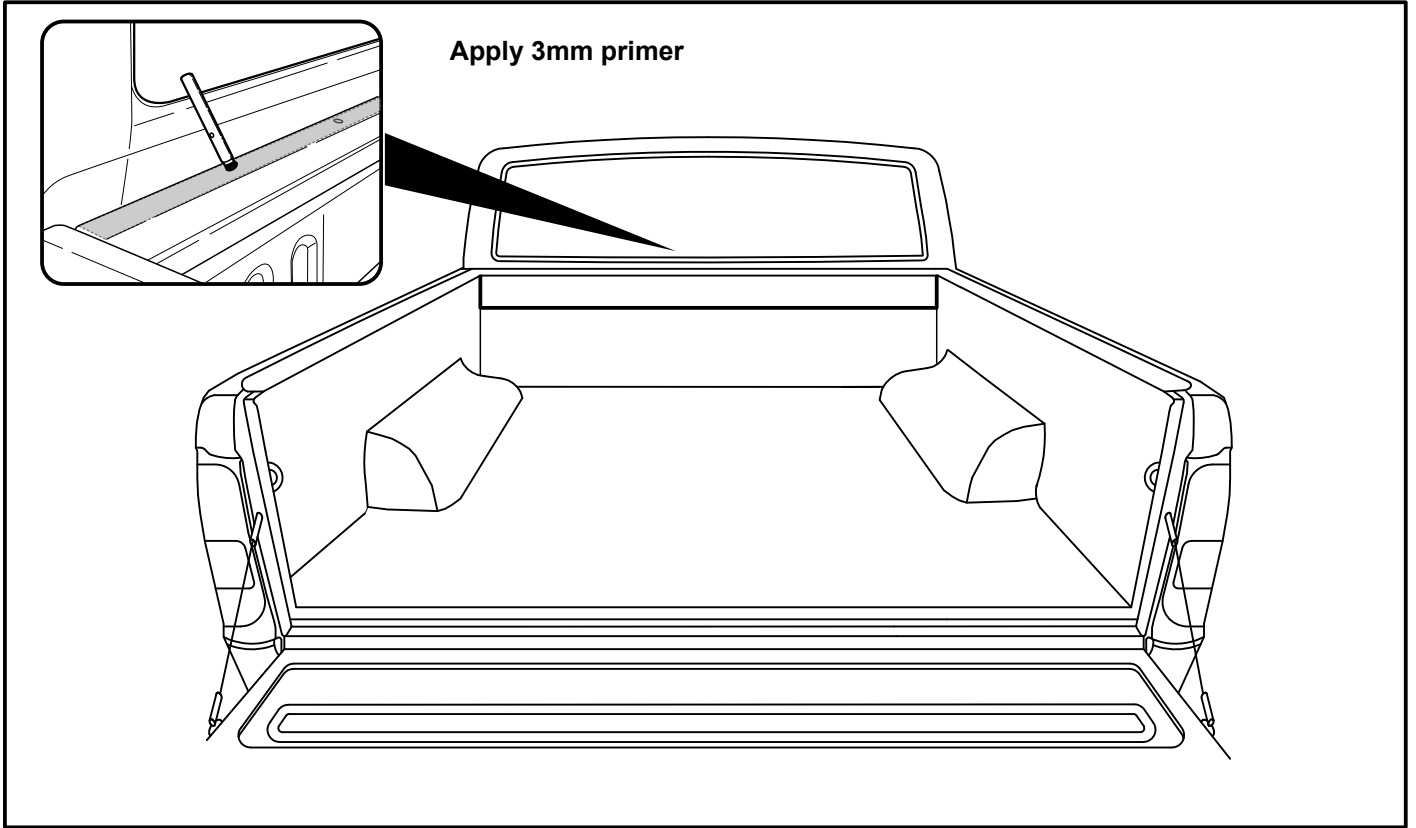

– Step 22

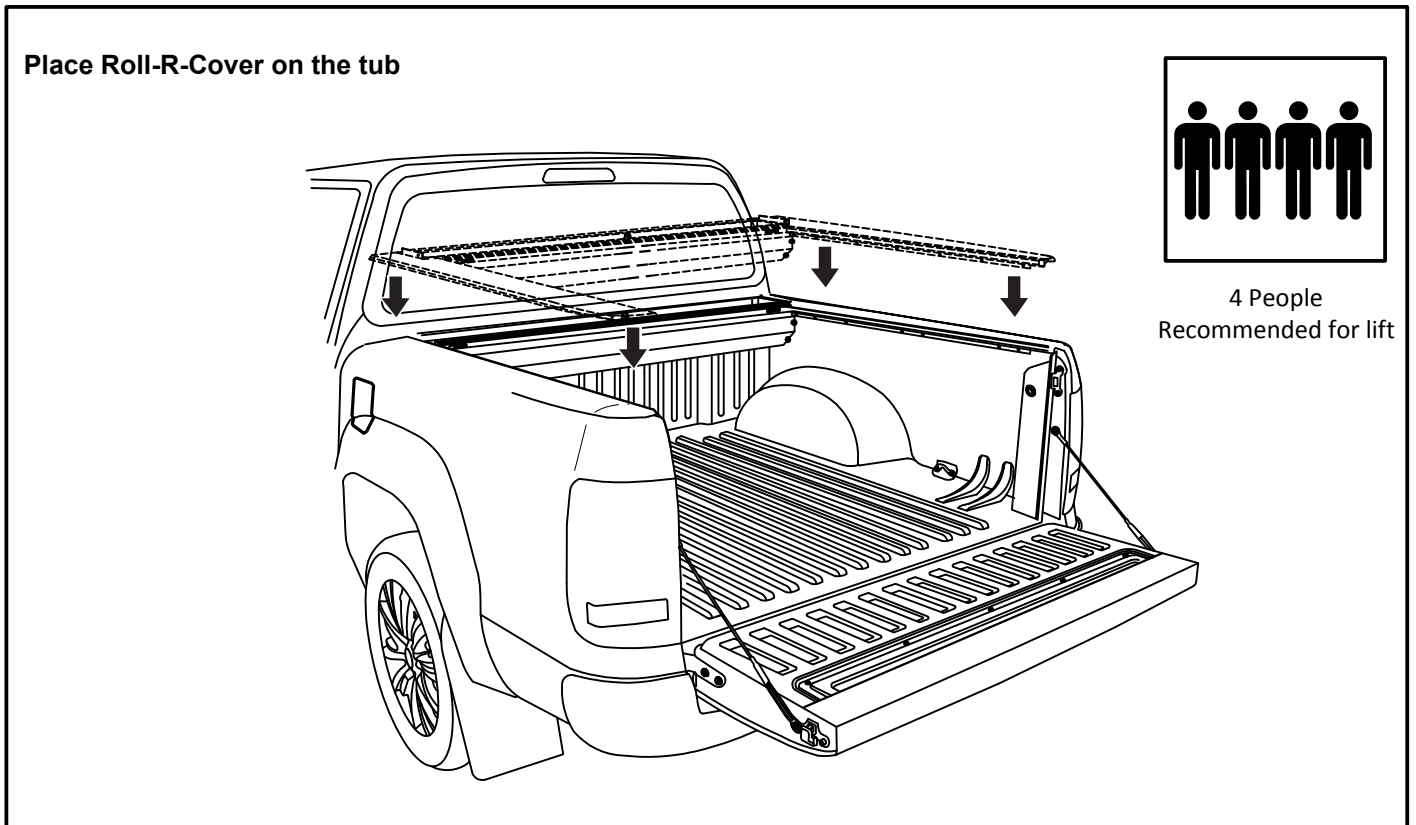

– Step 23

Before dropping the Roll R cover into place on the tub, connect all relevant connections or plugs to the receiver and motor plug connection.

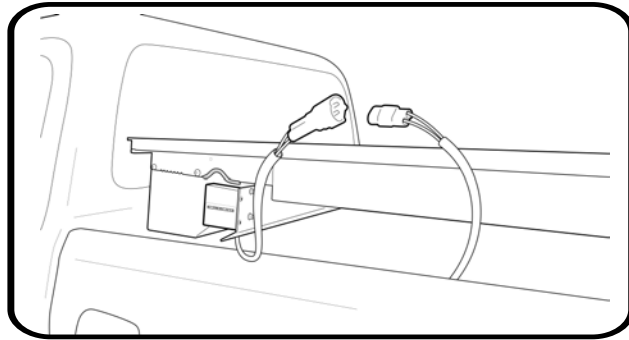
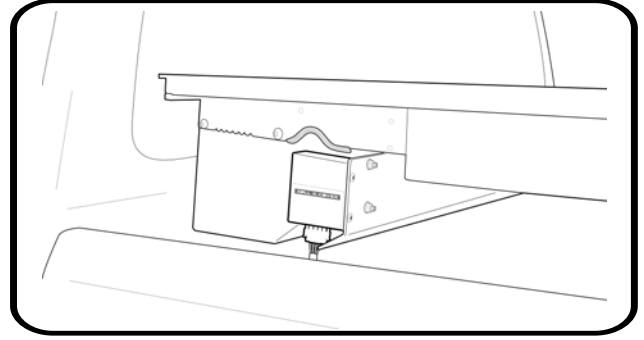
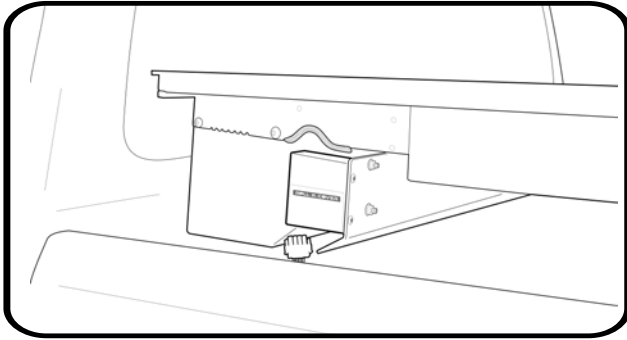

– Step 24

A

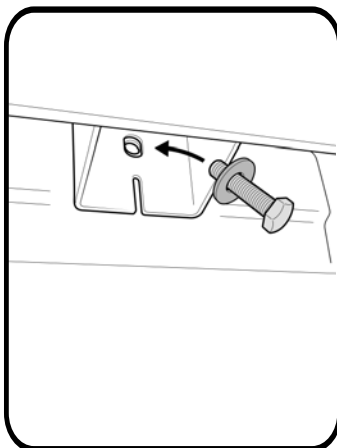

Using retained M8 Bolt and flat washer, feed through side rail tab

B

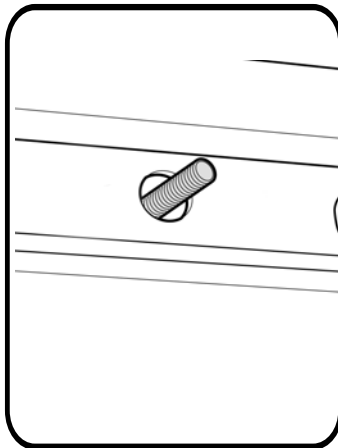

View from outside of tub.

C



Place flat washer and spring washer over bolt.

D

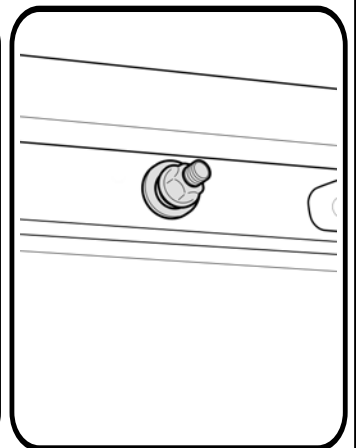

Place M8 Nyloc nut to M8 thread.

– Step 25

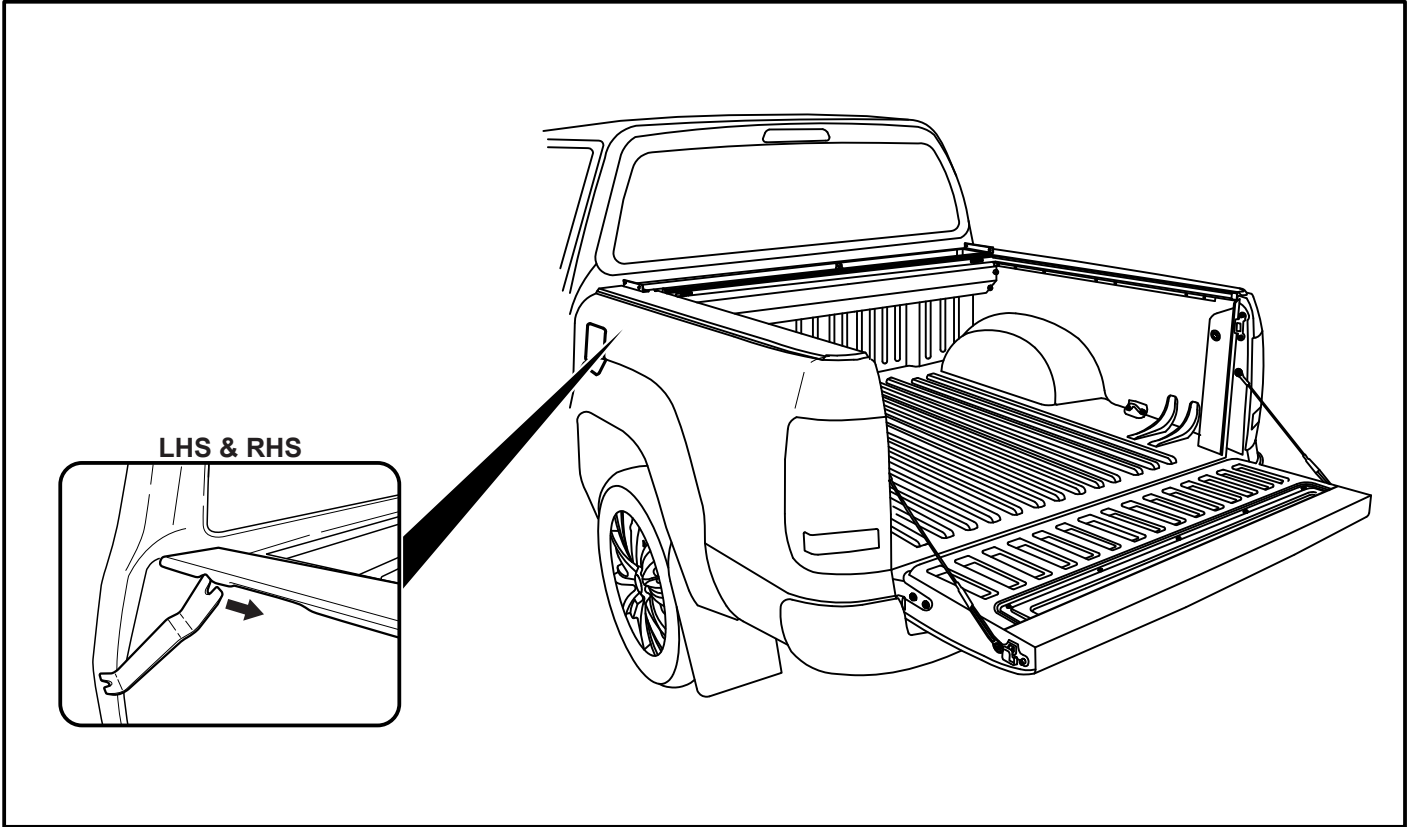

– Step 26

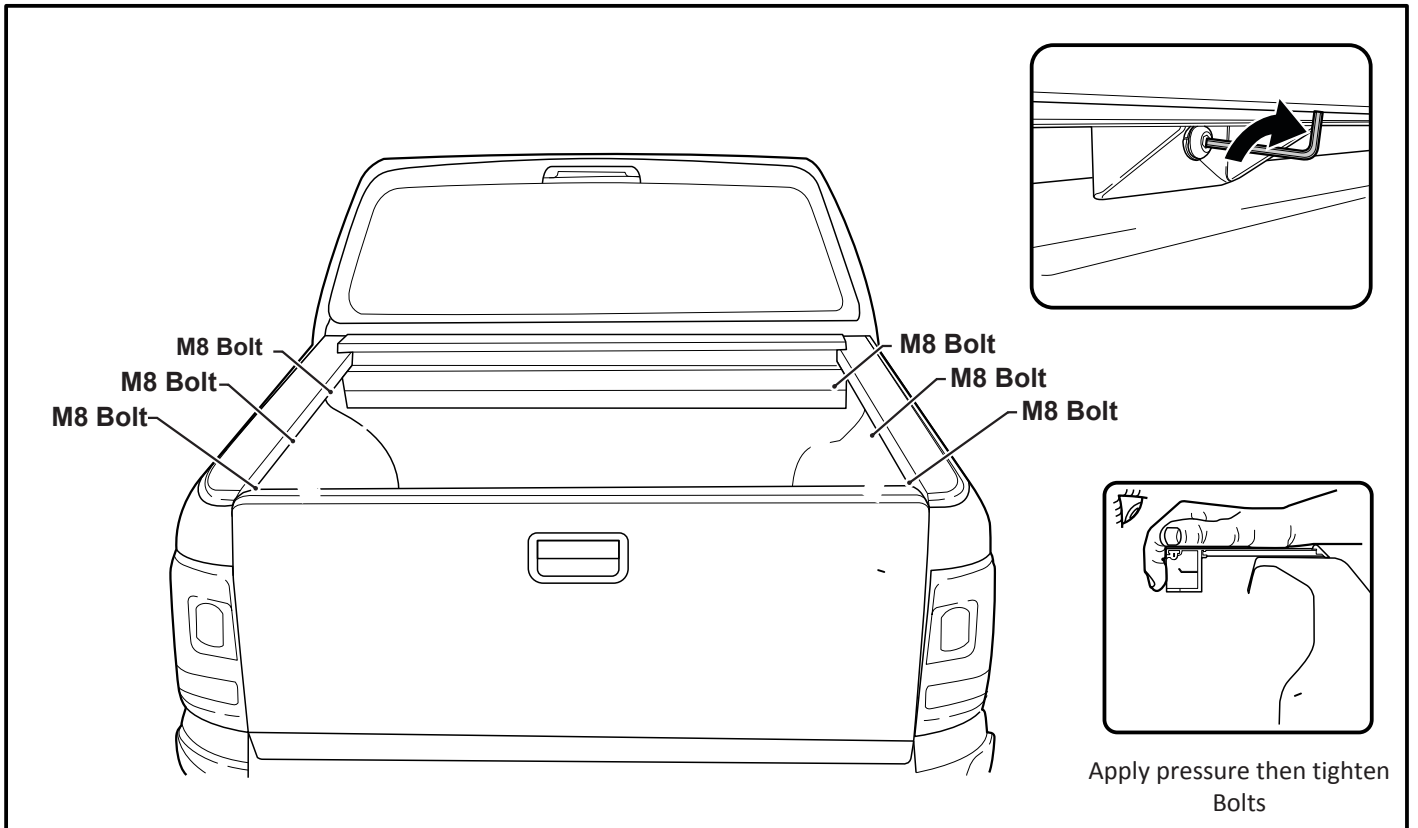

— Step 27 —

If curtain doesn't meet the tailgate in it's fully open position, loosen the clamps and shift the unit back.

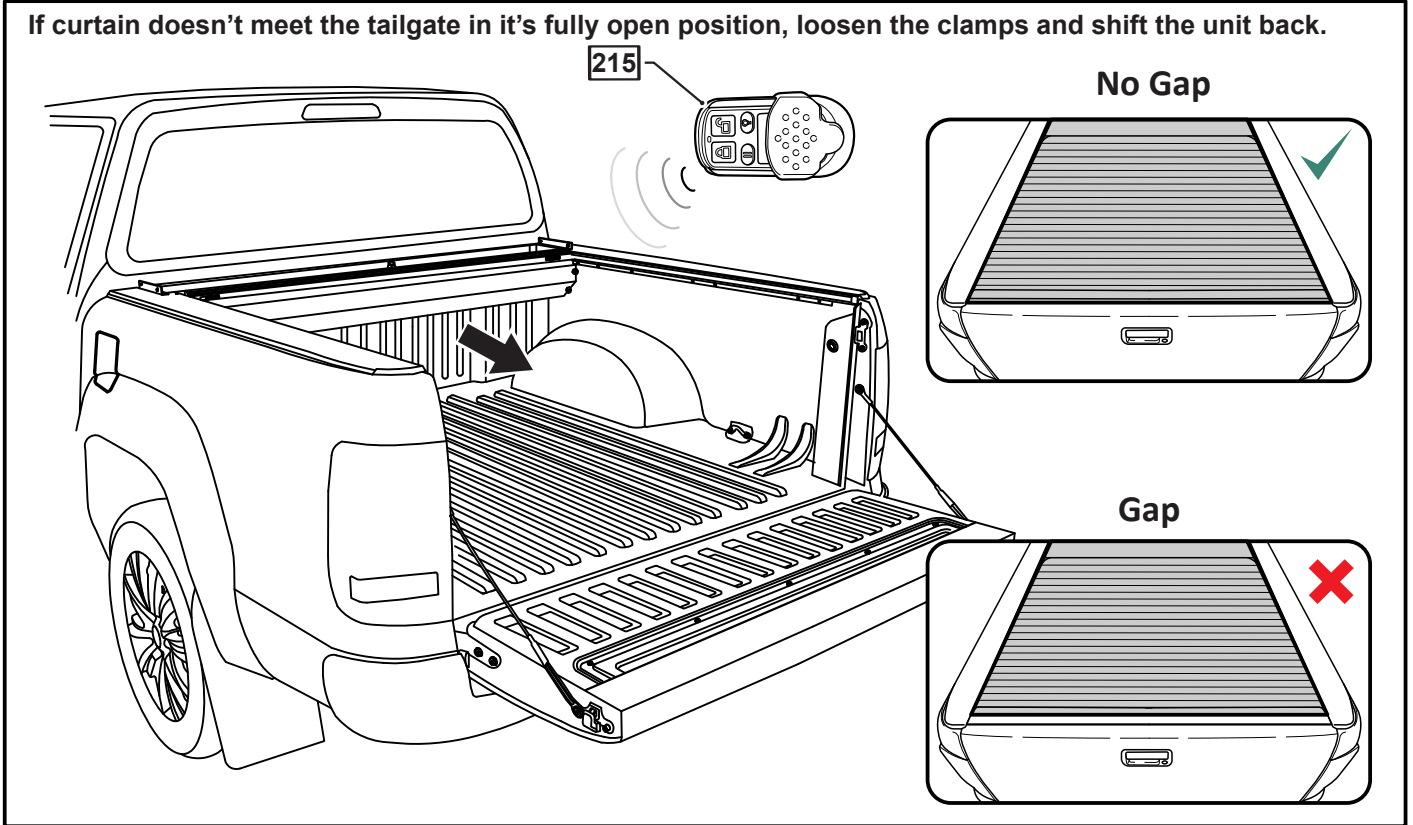

— Step 28 —

Peel double sided tape backing off and stick to vehicle.

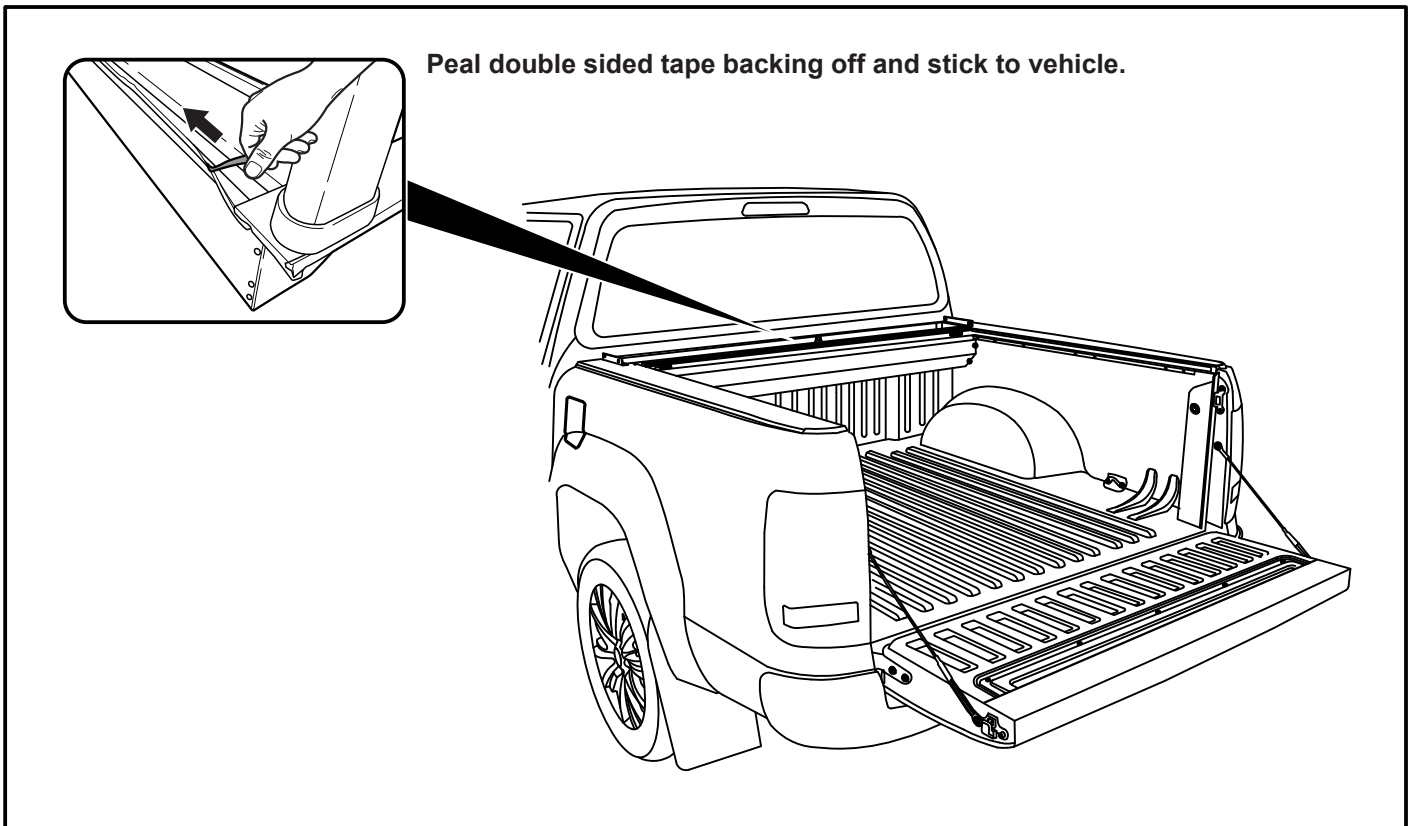

— Step 29

Drill through bed and liner (check for obstructions).

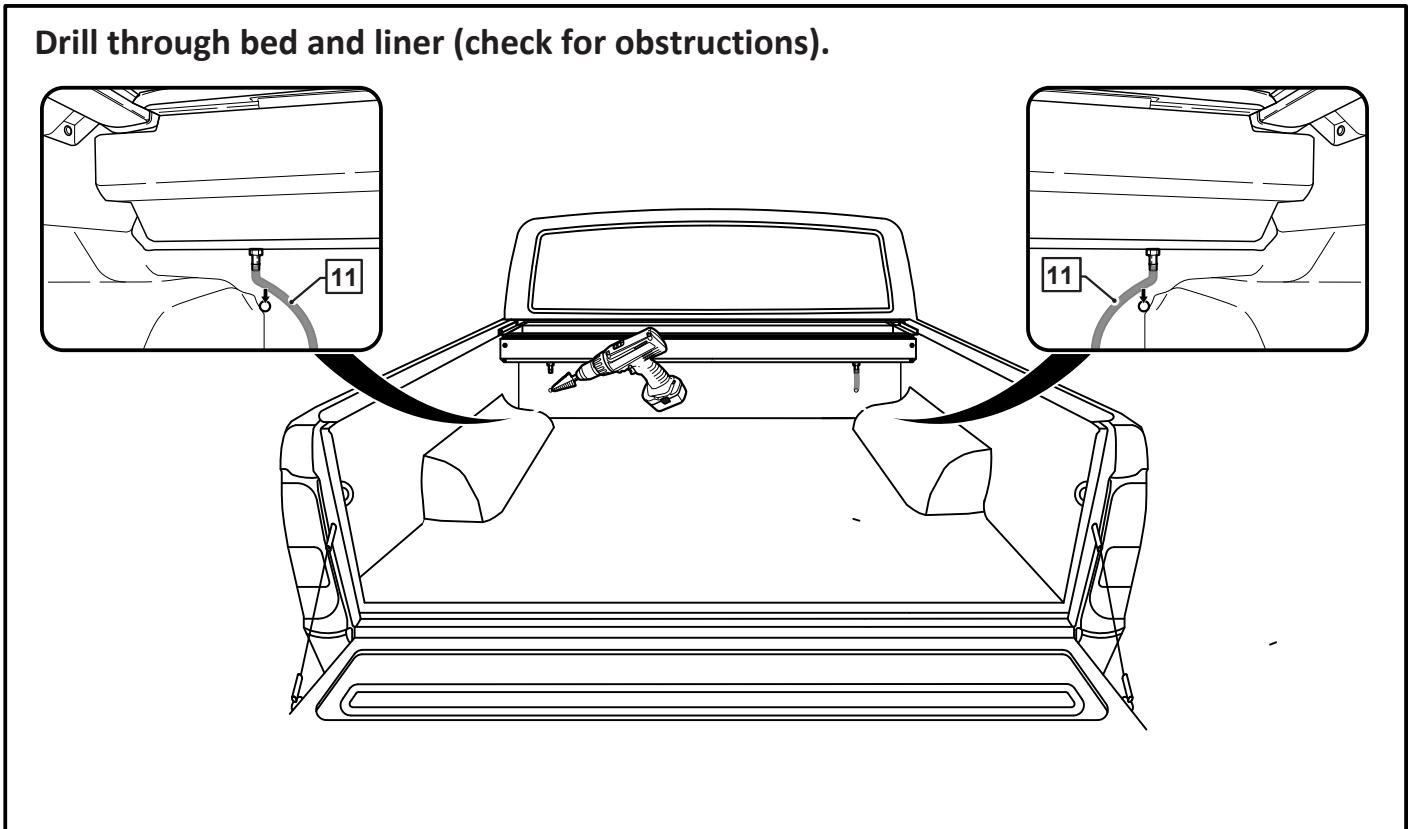

— Step 30

Remove the tail light to check for obstructions before drilling

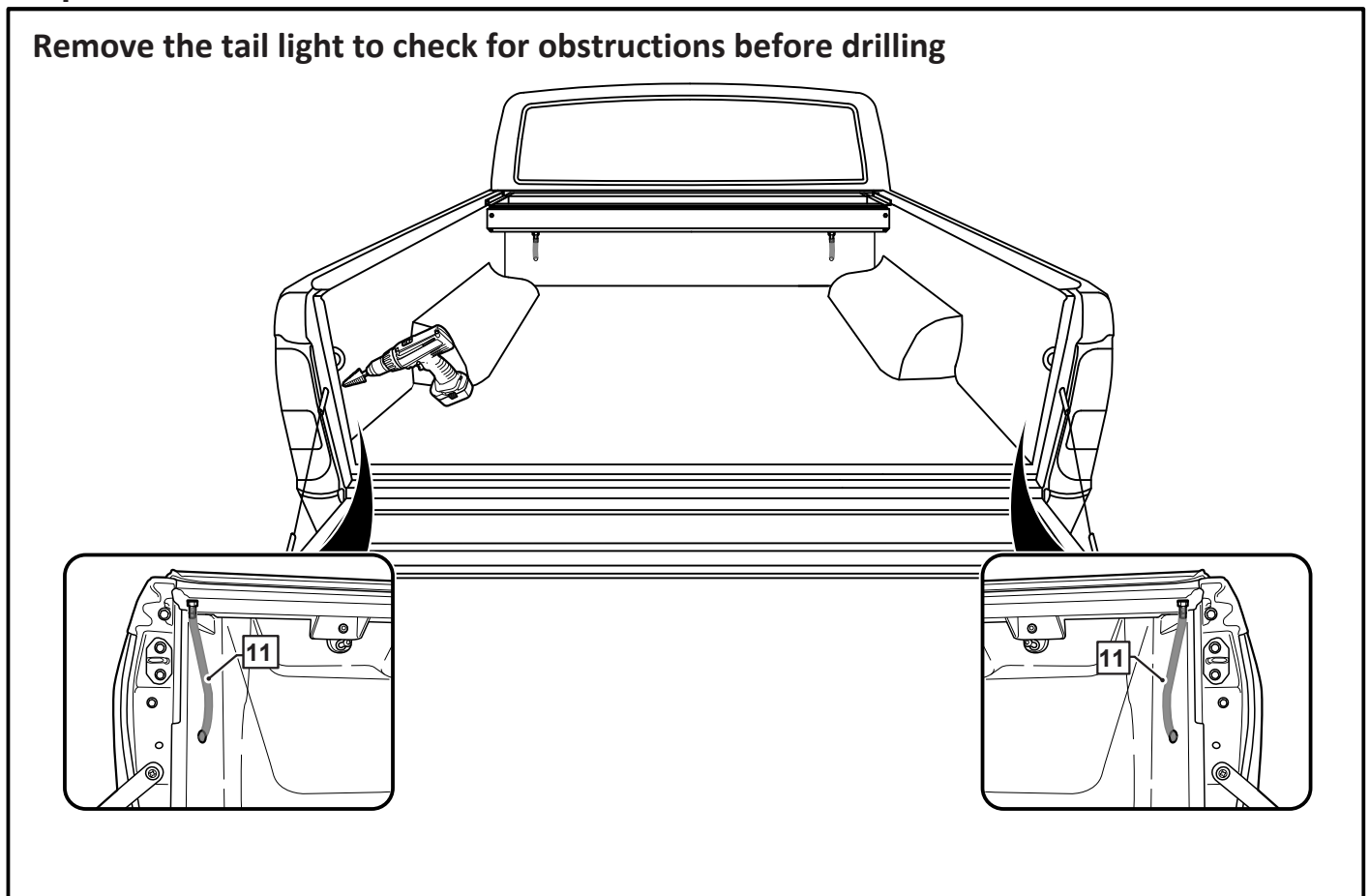

– Step 31

Snap fit the top cover.

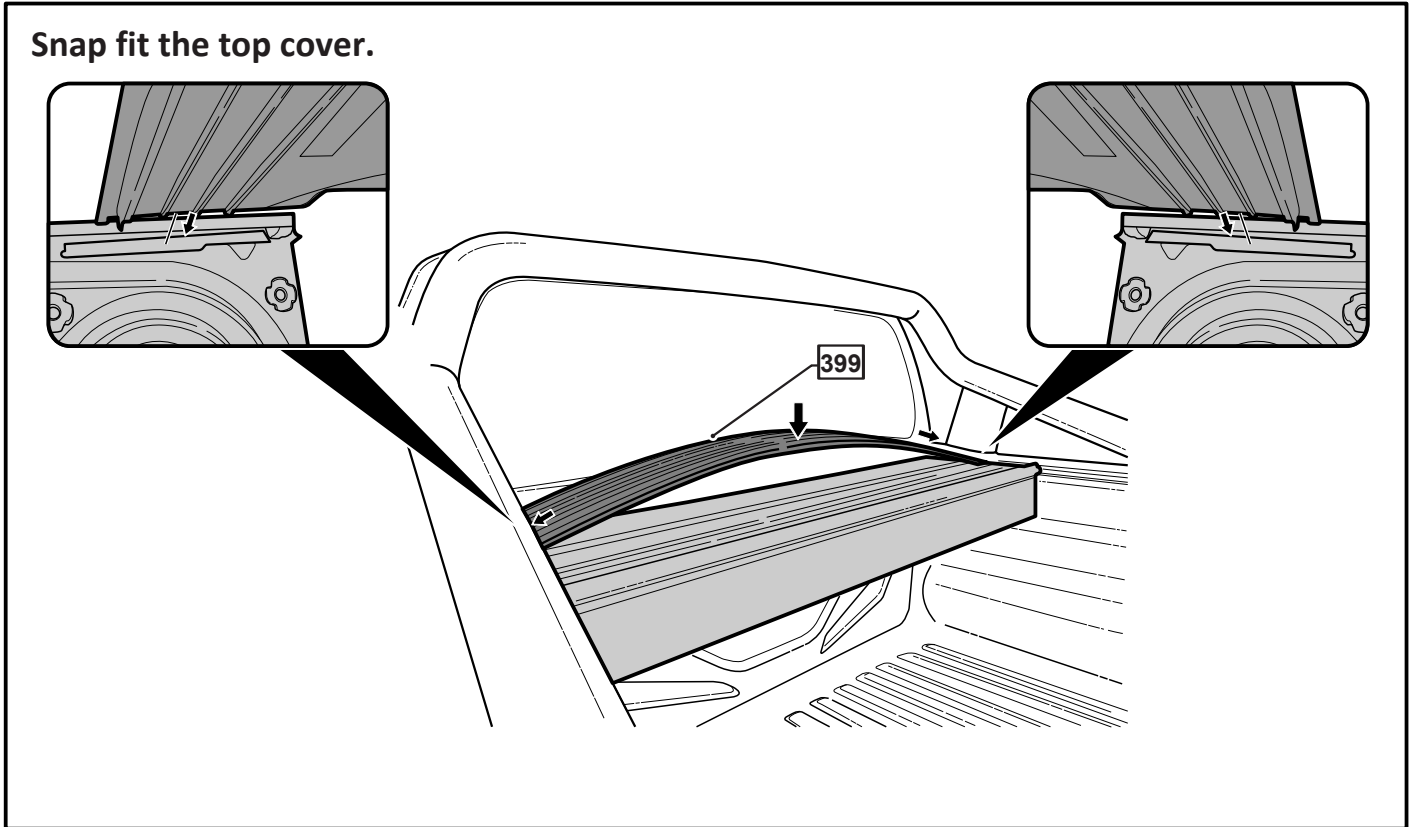

– Step 32

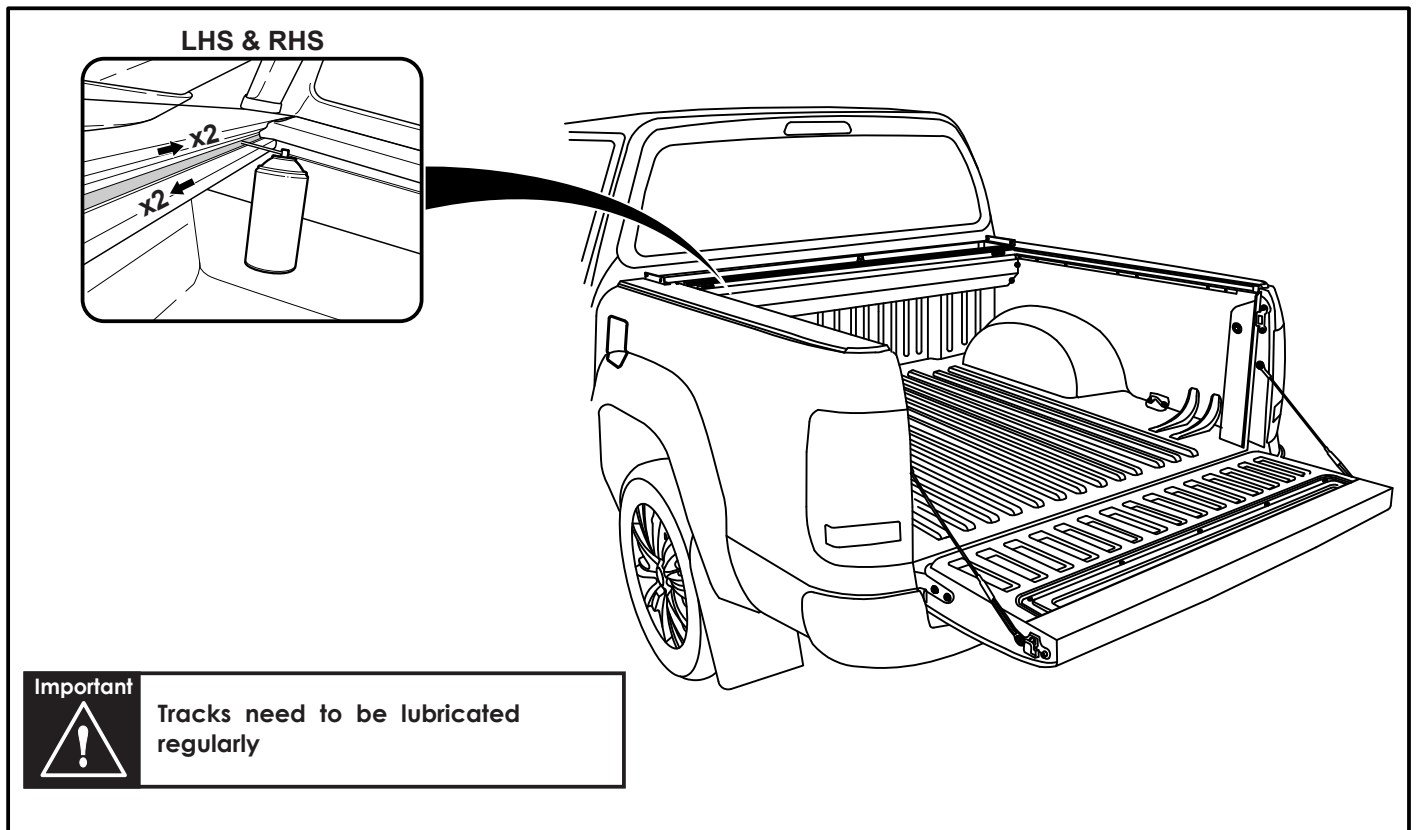

— Step 33 —

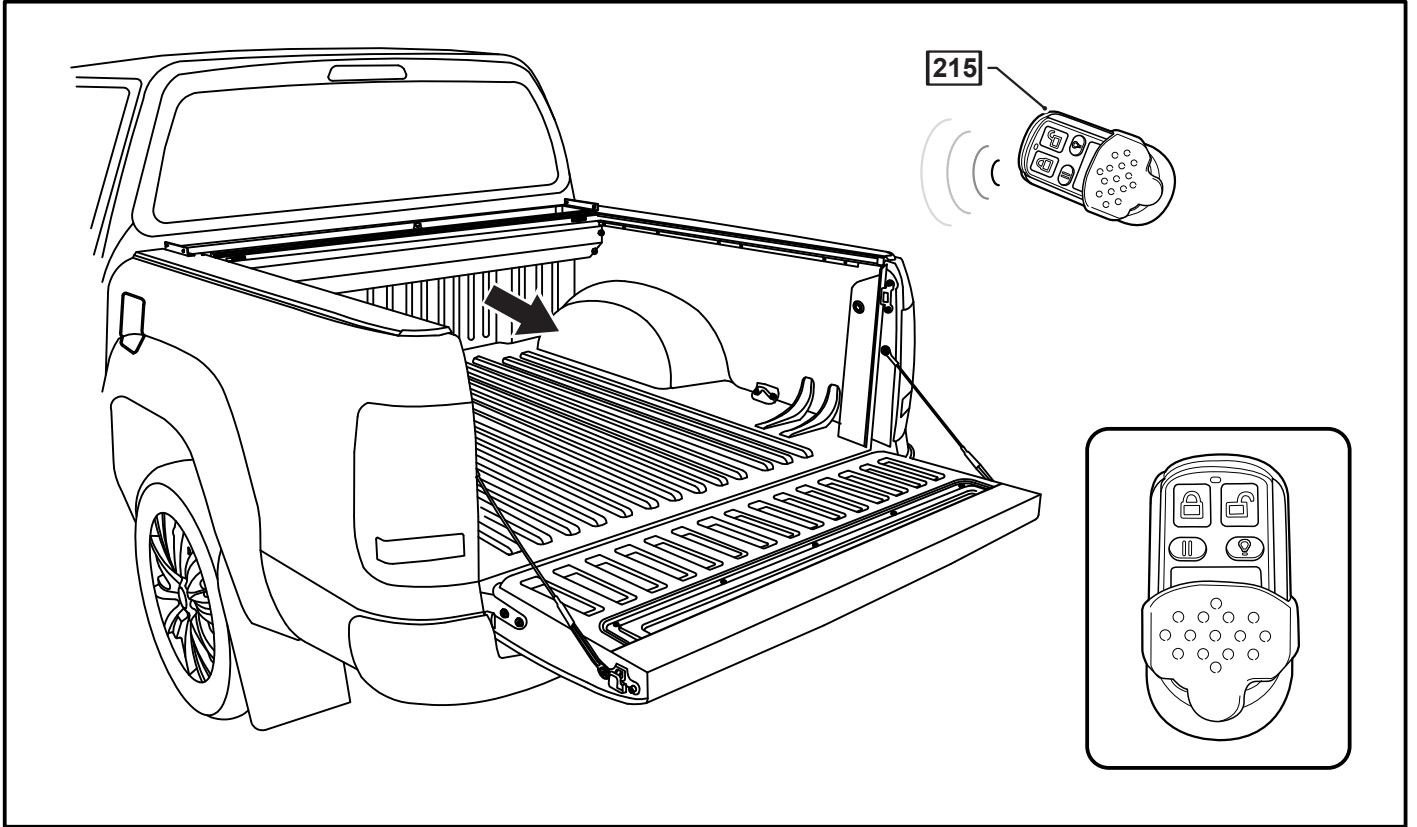

Important



You may open tailgate when Roll R Cover is in closed position, however you **MUST NOT** close the tailgate when Roll R Cover curtain is in the fully closed position.

WARNINGS!				www.hsputelids.com			
 NO STANDING	 ENSURE LOAD IS SECURE	 CHECK GLIDES OIL REGULARLY	 6Nm CHECK CLAMPS AND TIGHTEN	 DO NOT PLACE LOAD ON COVER	 CHECK DRAIN CLEAN CANISTER	 MECHANICAL HAZARD	 NO PEOPLE OR ANIMALS UNDER ROLL TOP

E. & O.E. This document is copyright and must not be used except as permitted below or under the Copyright Act 1968. You may reproduce and publish this document in whole or in part for your or your organisation's own personal or internal compliance, educational or non-commercial purposes. You must not alter or amend this document in any way. You must not reproduce or publish this document for commercial gain without the prior written consent of the copyright owner.