



WWW.HSPUTELIDS.COM

Part No: P5R

Fitting Time: 180 minutes

ROLL. R. COVER

To suit Ford Ranger PX Space Cab 2011+

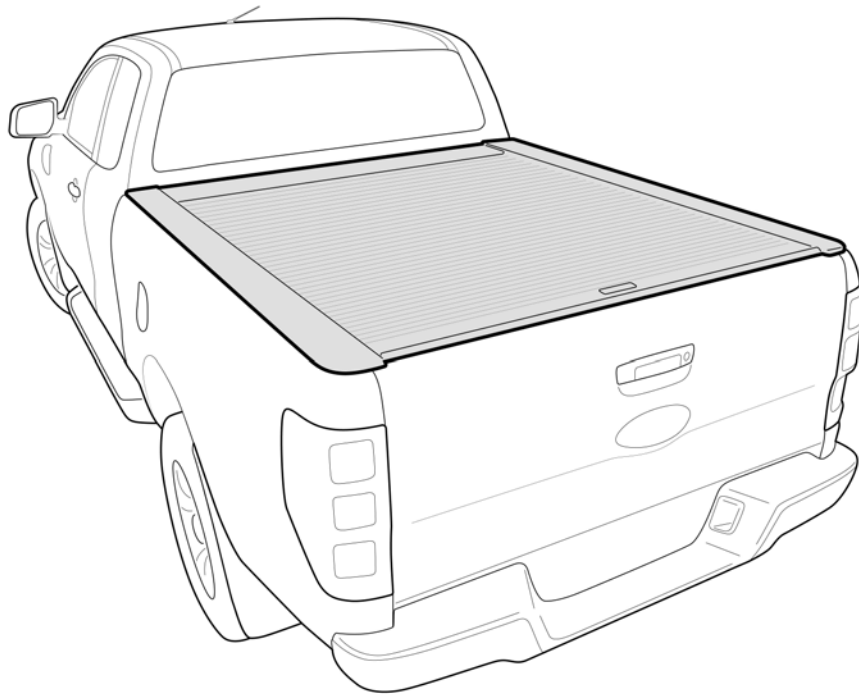

Roll-R-Cover

Fitting Instructions

– General Notes

- Read through the fitting instructions before installation of accessory.
- Always install the Roll R Cover Wiring Kit following the workshop manual and fitting instructions provided. Failure to do so may cause damage to the vehicle or the accessory.
- Ensure all recyclable components and packaging are discarded and recycled following local recycling regulations.
- It is always recommended that the Roll R Cover Wiring Kit is fitted by a qualified automotive technician.
- Safely store and protect any removed vehicle components.

– Safety Notes

- Check that all work practices comply with safety standards.
- Please wear appropriate clothing and use safety equipment.



– Fitting Time



180 minutes

– Parts Supplied

P5R	EXTRA CAB FORD RANGER PX & PU - ROLL R COVER		
PART DESCRIPTION	PART NUMBER	QUANTITY/LENGTH	CHECK
PSR FITTING INSTRUCTIONS	384*	1	
LUBRICANT PUMP SPRAY	47*	1	
REMOTE	215*	2	
PRIMER STICK	44*	1	
CABLE TIE 4.8X300MM	217*	10	
ROLL R LOOM	216*	1	
PSR CANISTER AND CURTAIN	278*	1	
PSR RAIL RIGHTHAND	337*	1	
PSR RAIL LEFTHAND	338*	1	
HOSE 600MM	11*	4	
BLACK NITRILE FOAM 6MMX25MMX1.6M	391*	1	
COMPLETE CANISTER COVER	404	1	
OPERATION LEAFLET	66	1	
MAINTENANCE LEAFLET	67	1	
RIGHT ANGLE BRACE BRACKET	RBRH	1	
RIGHT ANGLE BRACE BRACKET	RBLH	1	
ADJUSTMENT PLATES	31	2	
BLACK PUTTY	3*	8	

**The following steps are for vehicles with bed liners.
If there are no bed liners installed move to Step 4**

– Step 1

Trim front of bed liner by 180mm from the top of the ute bed as shown.

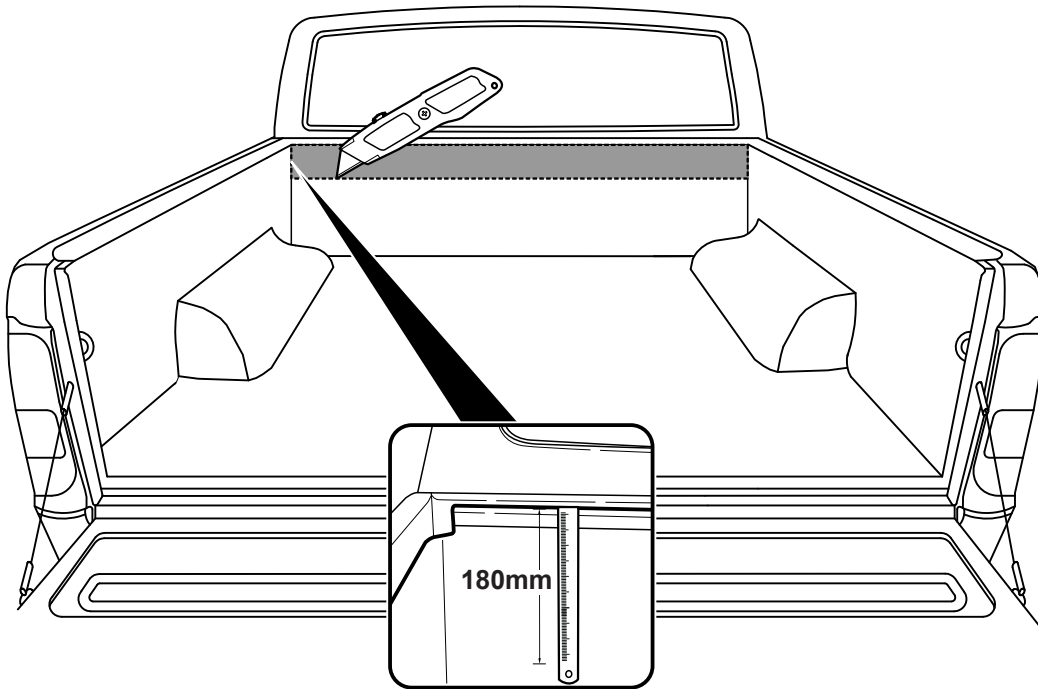

– Step 2

Cut a 20mm split for bed liner to flex.

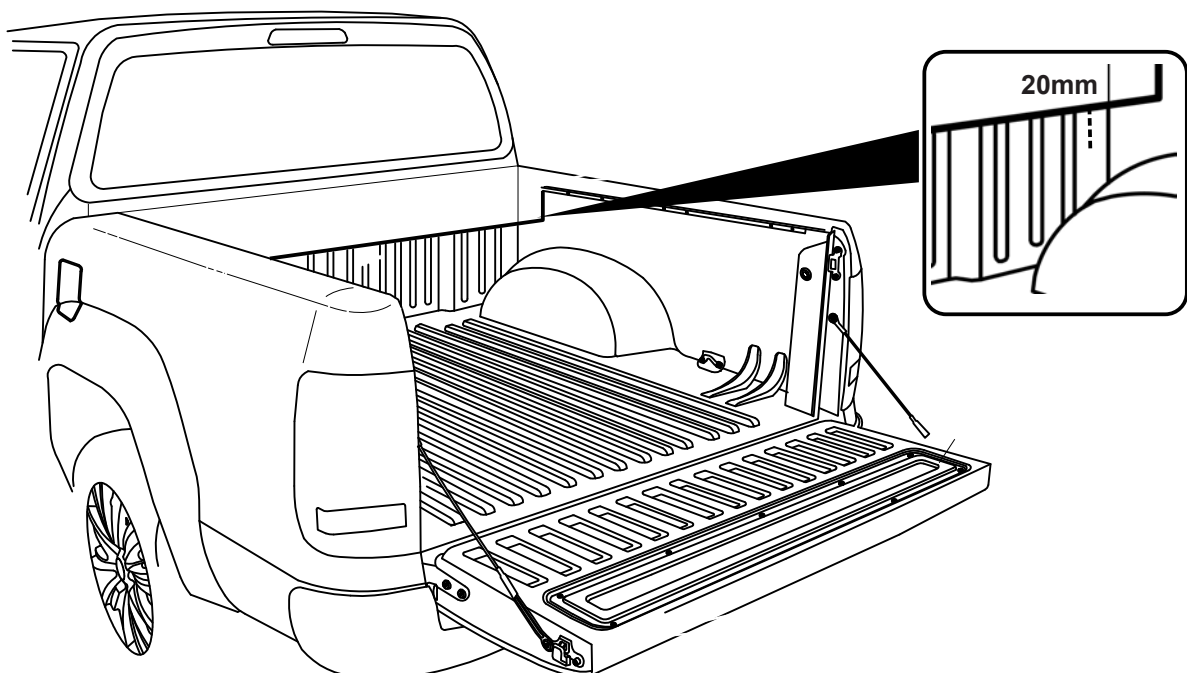

— Step 3 —

Measure 20mm down from top of tailgate and trim tailgate liner.

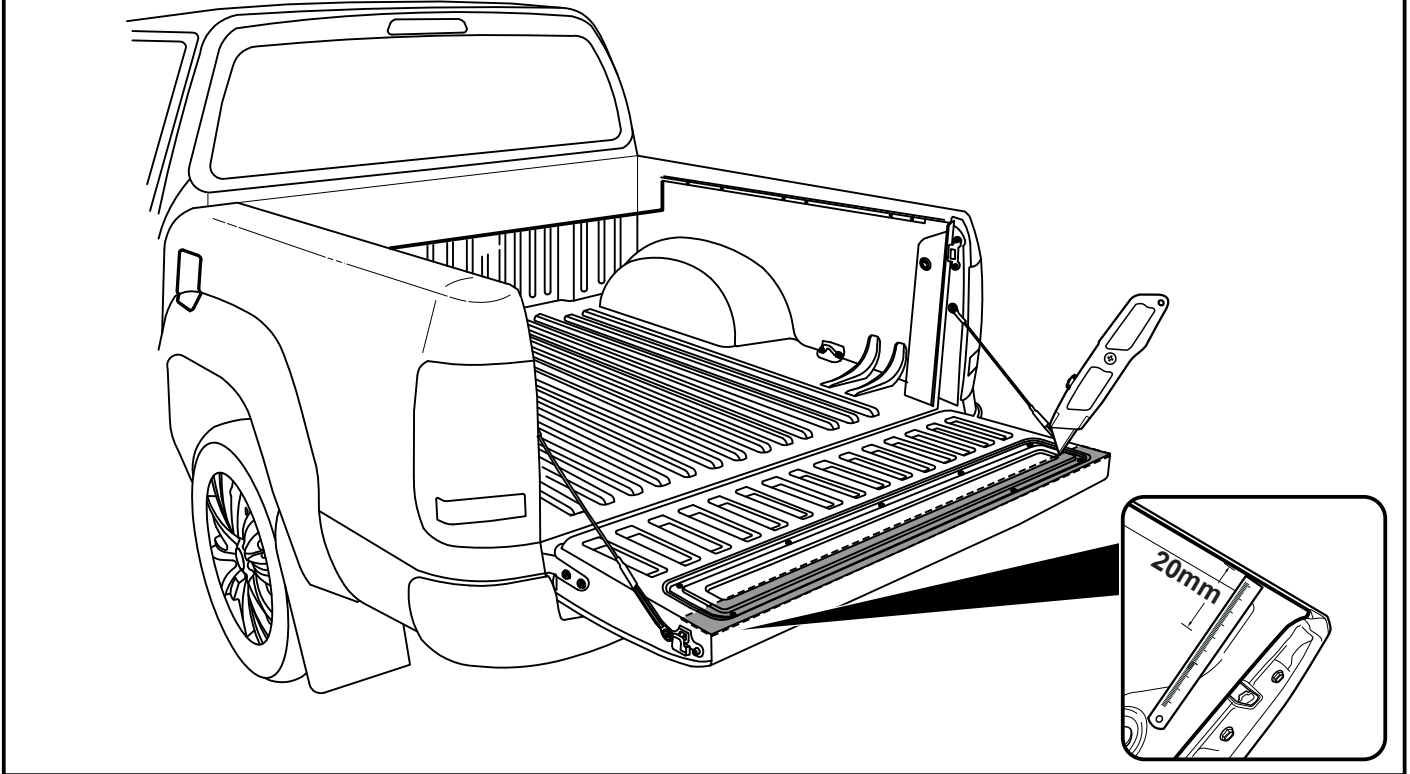

— Step 4 —

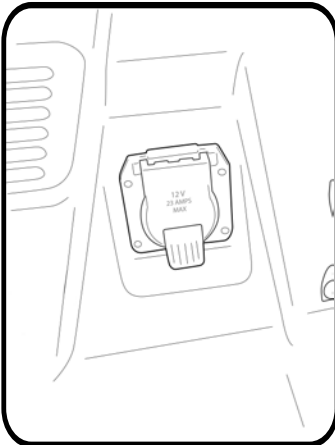
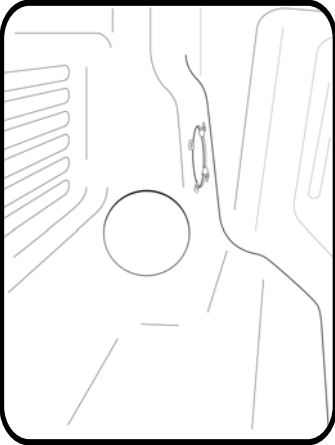
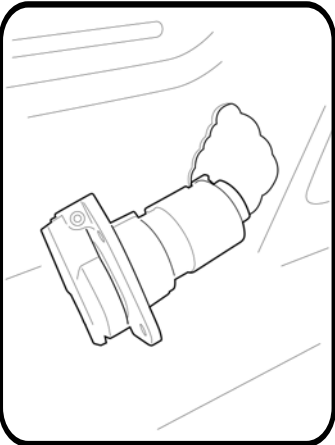
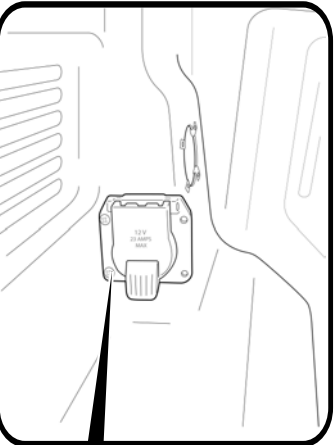
A	B	C	D
			
<p>Remove unit and unplug from loom</p>	<p>Make a 50mm hole</p>	<p>Feed loom through the hole and plug into power unit</p>	<p>Secure power unit with two screws to the left only</p>

— Step 5 —

Roll-R-Cover preparation steps

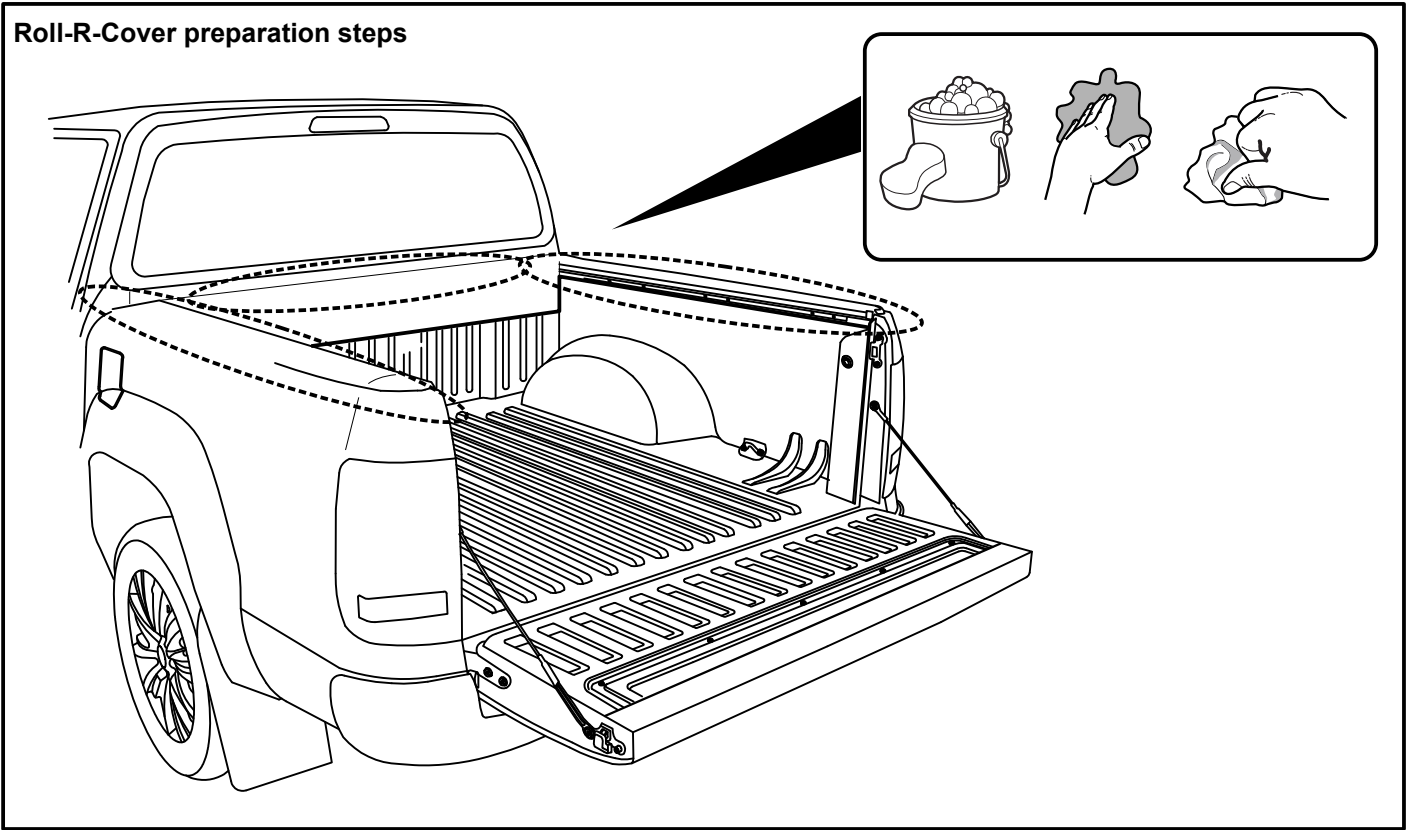

— Step 6 —

Carefully unpack the box.

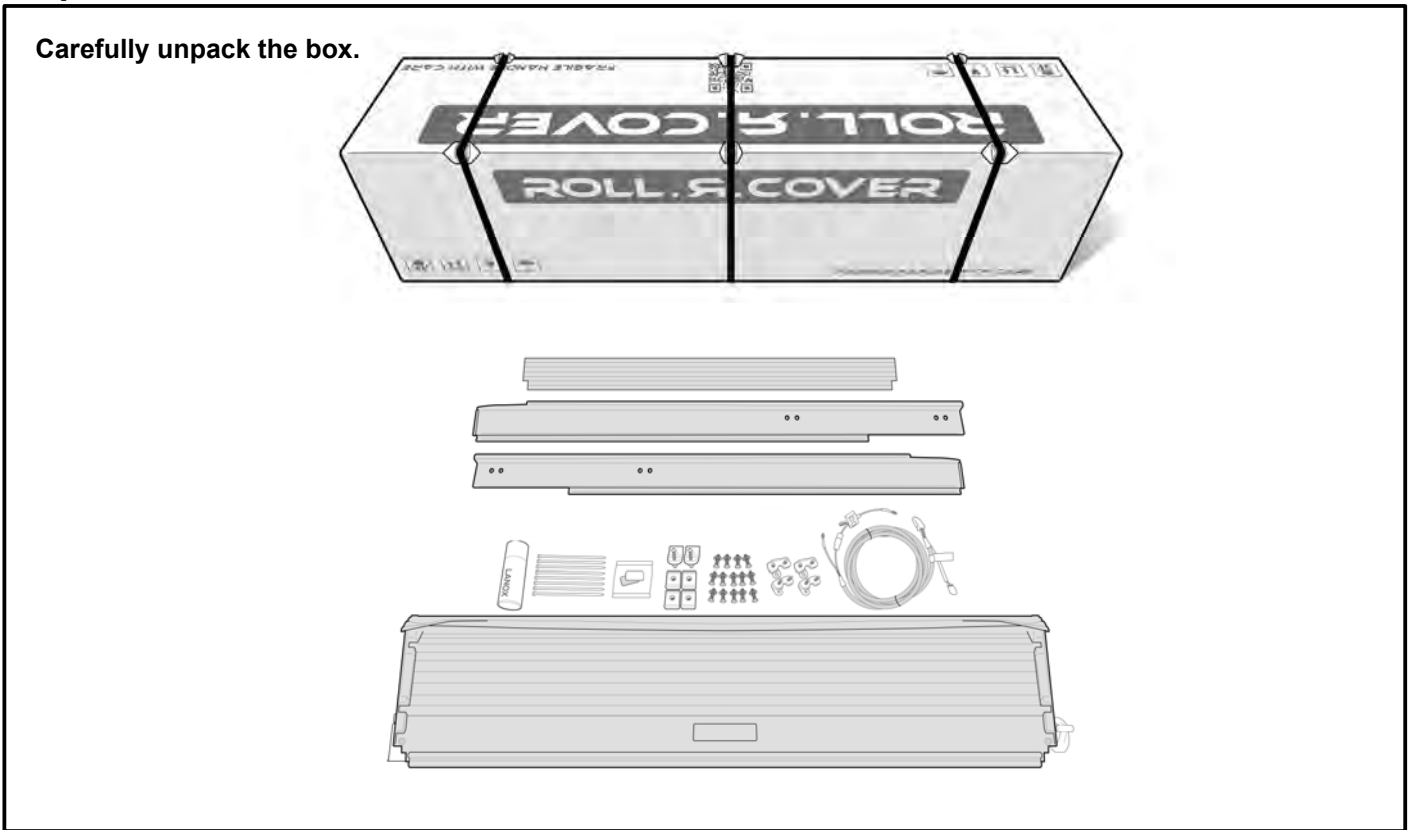

– Step 7

Wiring Harness steps

1 Feed through the cavity

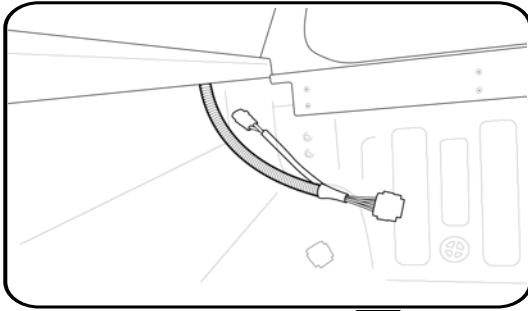

3

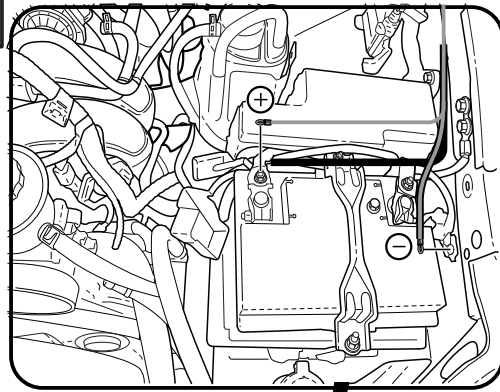

2

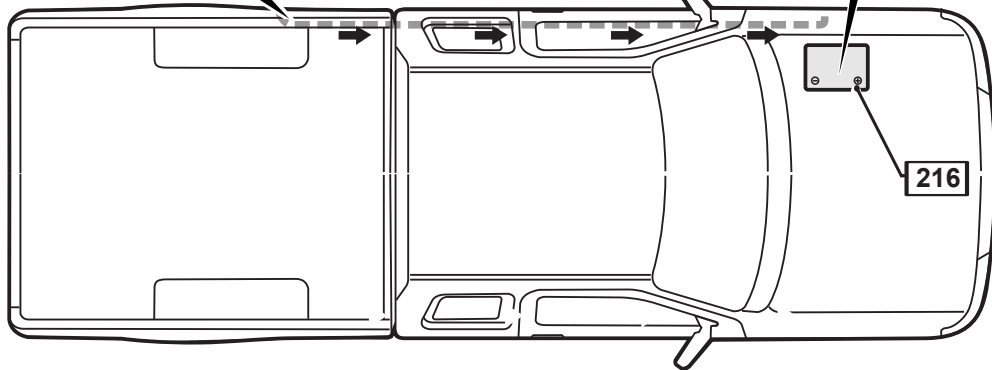

Run the wiring from the front corner cavity to the battery over the chassis rail. Making sure to keep away from hot obstructions and cable tie every 400mm.

– Step 8

Remove M8 Bolt & M8 Spring Washer

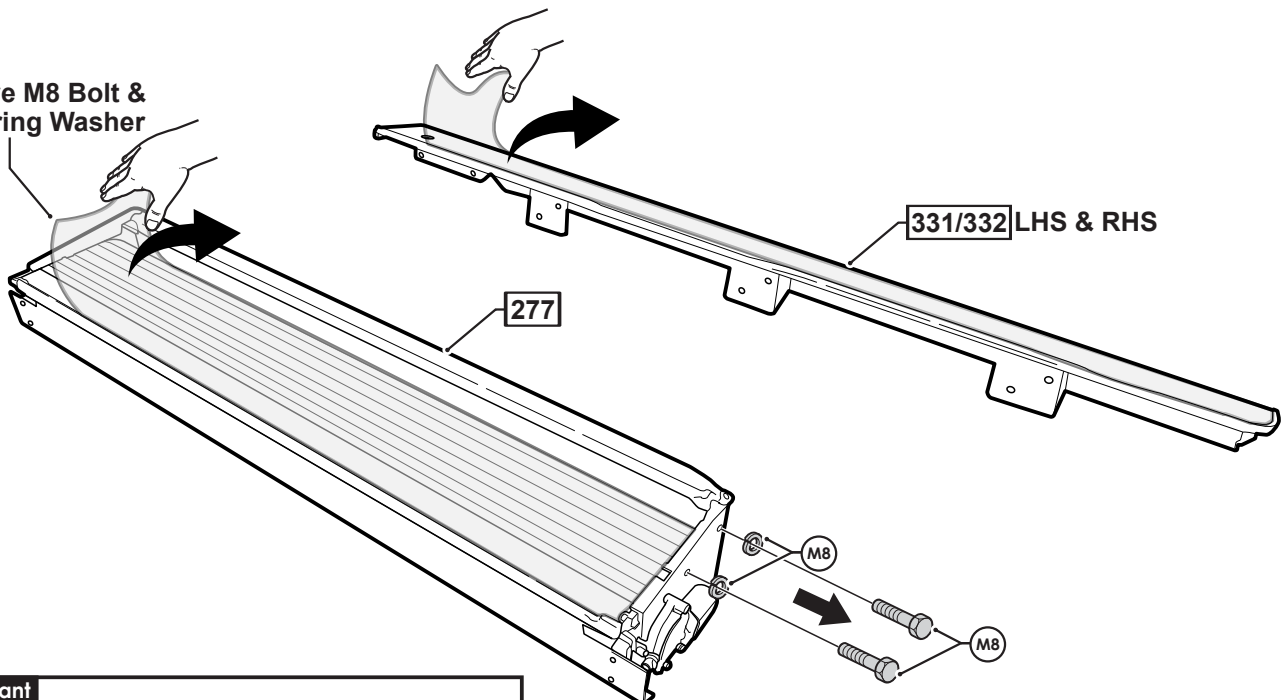

Important



Ensure the black tar is not removed with the film.

– Step 9

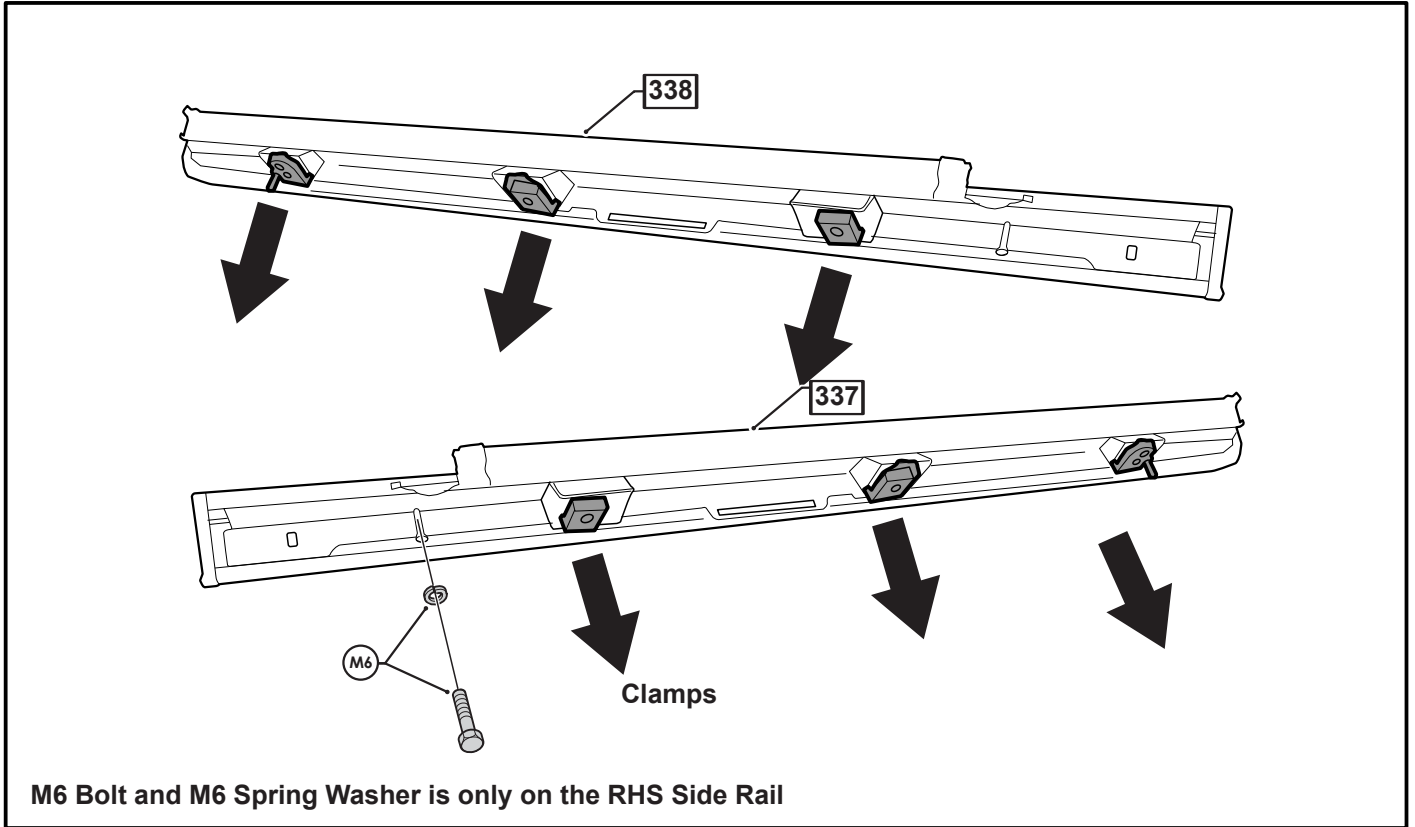

– Step 10

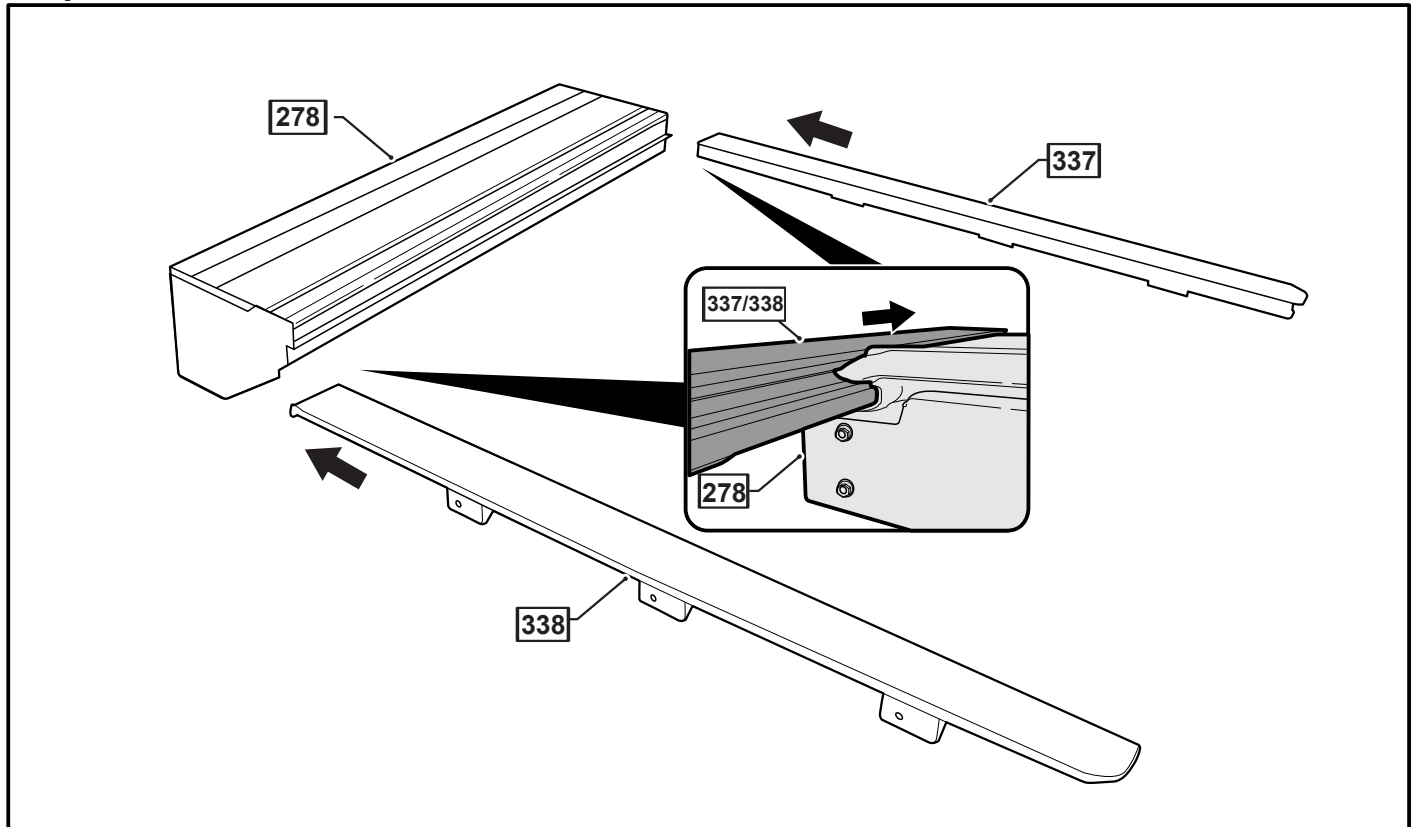

– Step 11

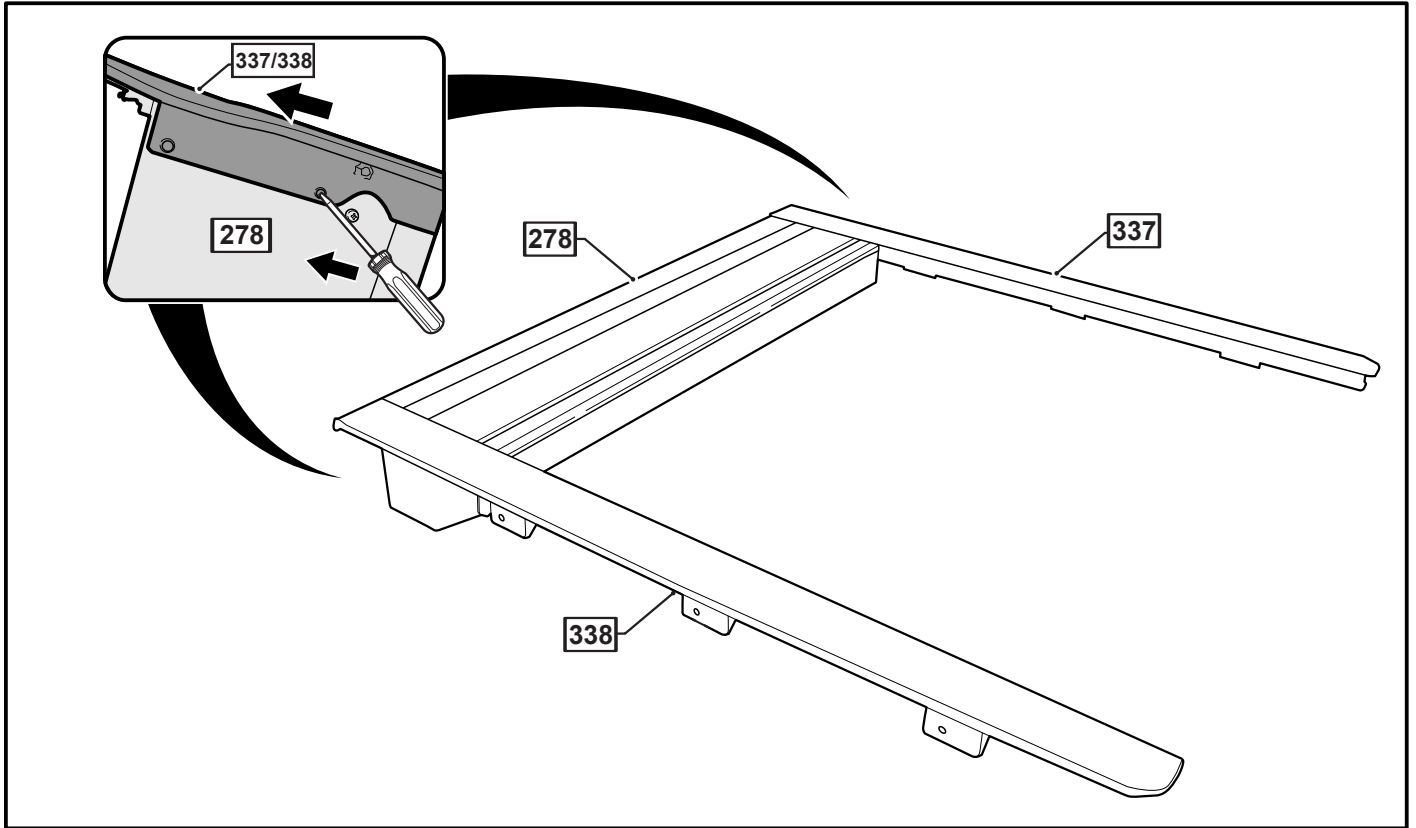

– Step 12

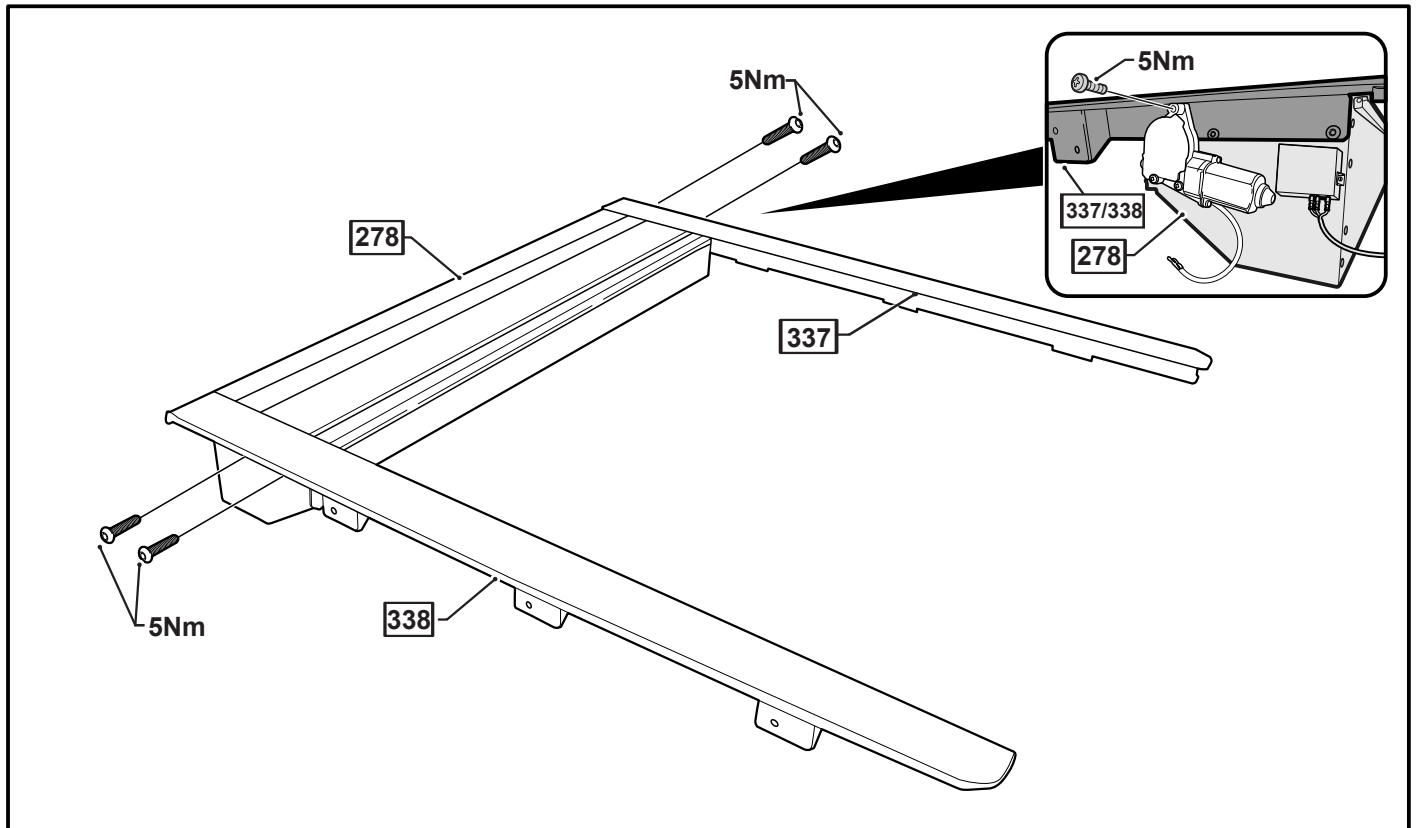

– Step 13

Apply tar sealant to the gap under water channel.

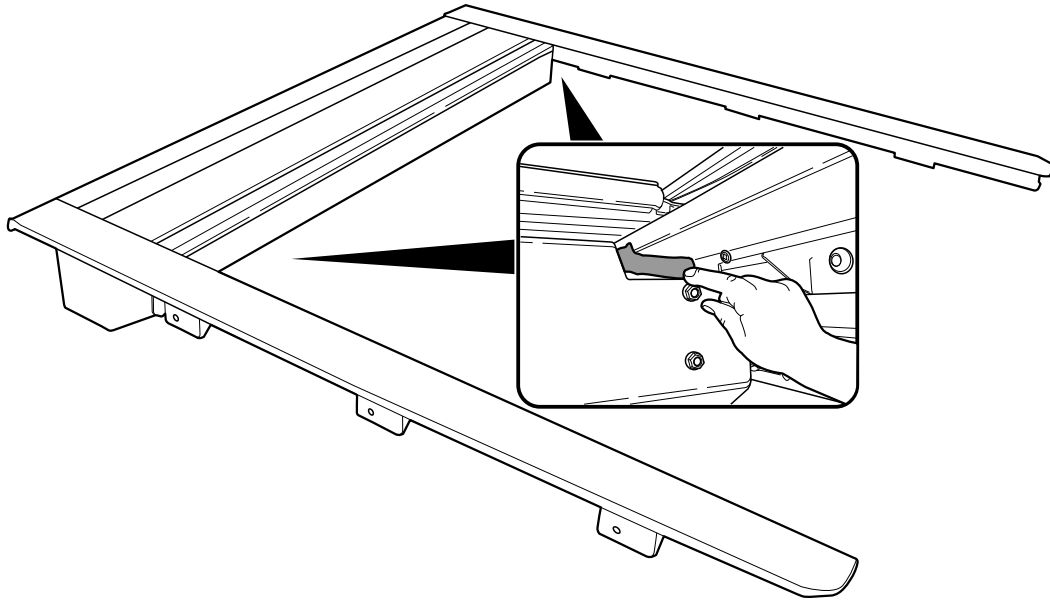

– Step 14

Apply tar sealant to both sides of the canister as shown (where accessible).

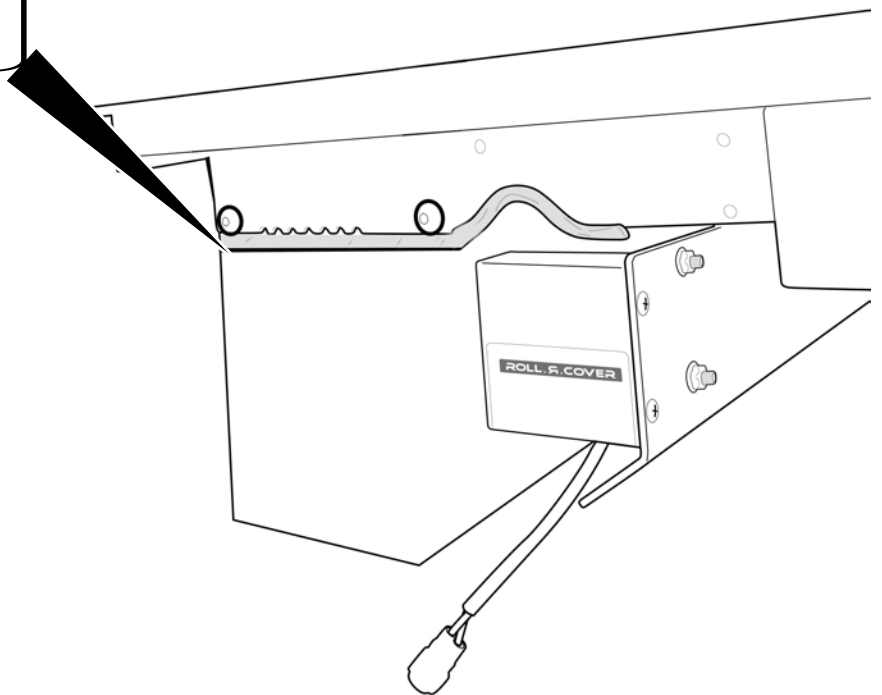

– Step 15

Run foam seal provided along the front of the tub to make headrail level with sides with sides.

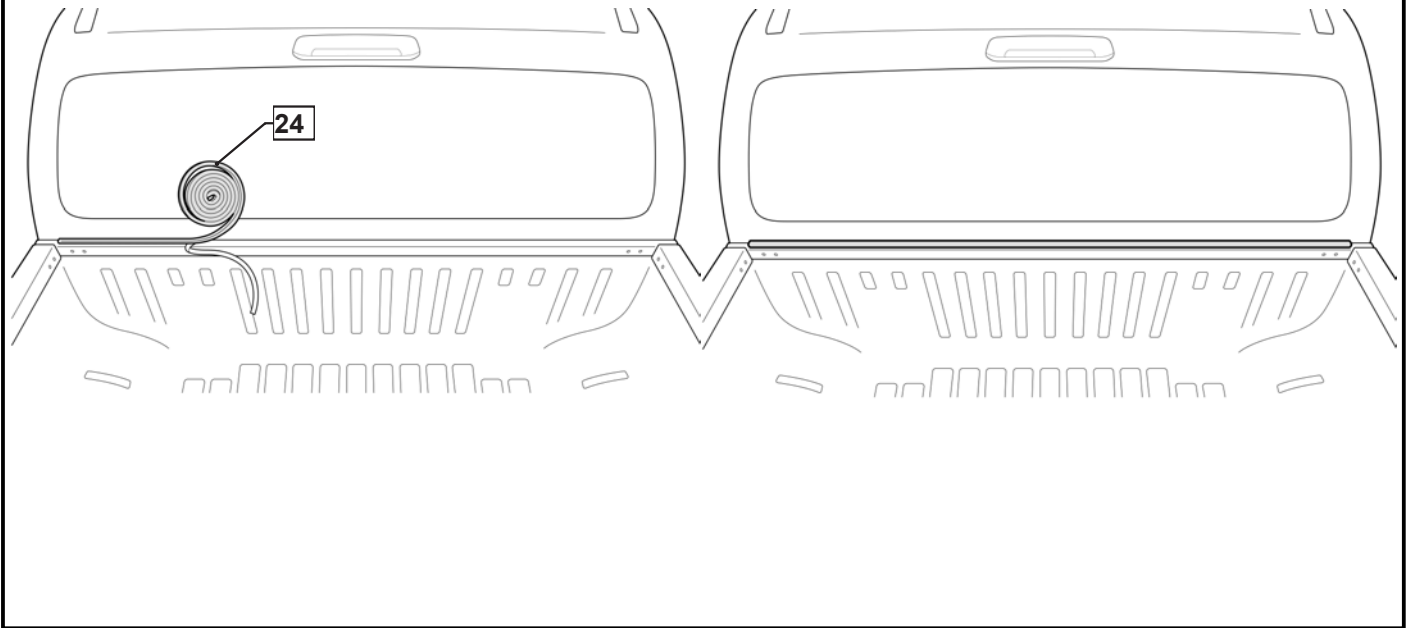

– Step 16

Seal any exposed gaps.

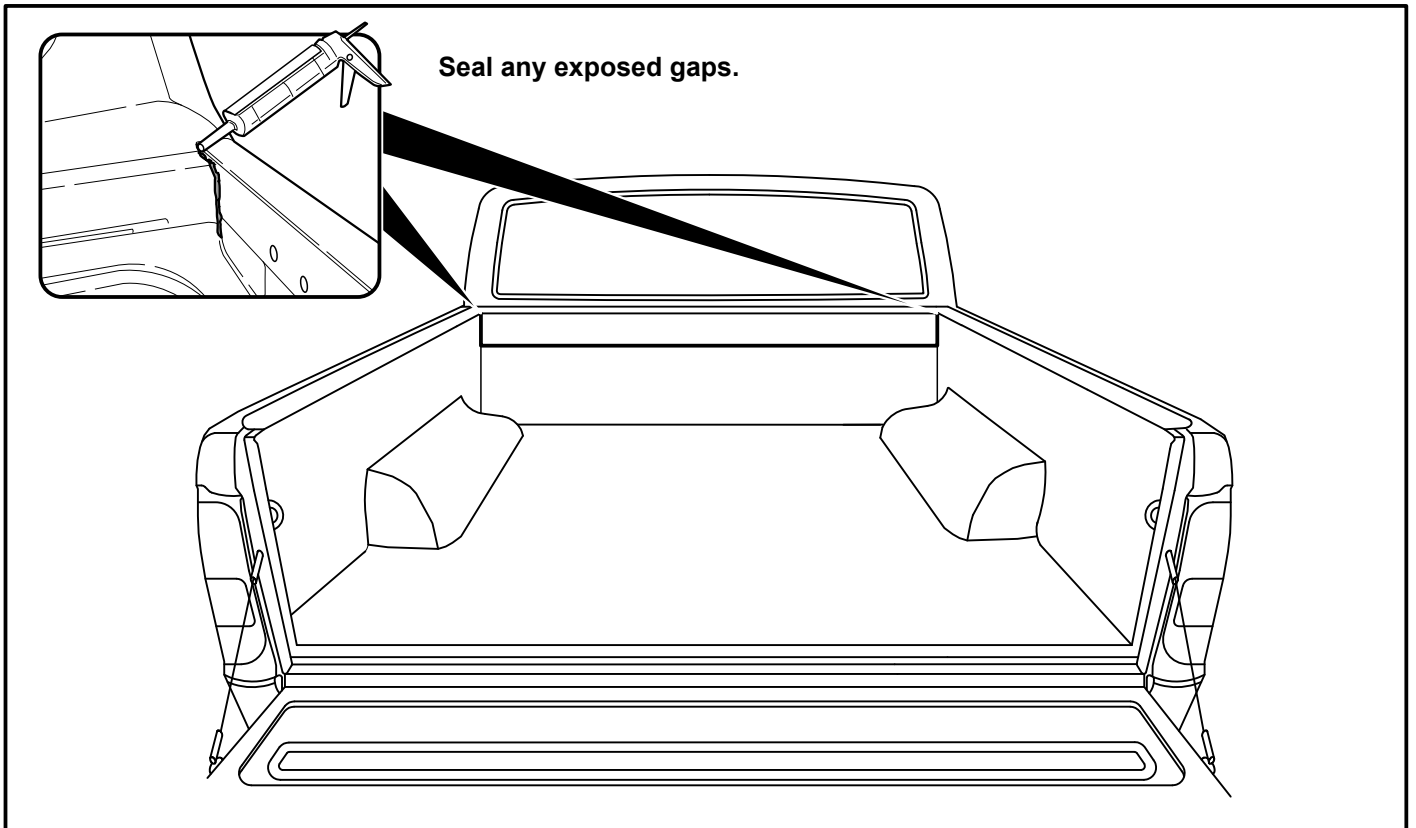

– Step 17

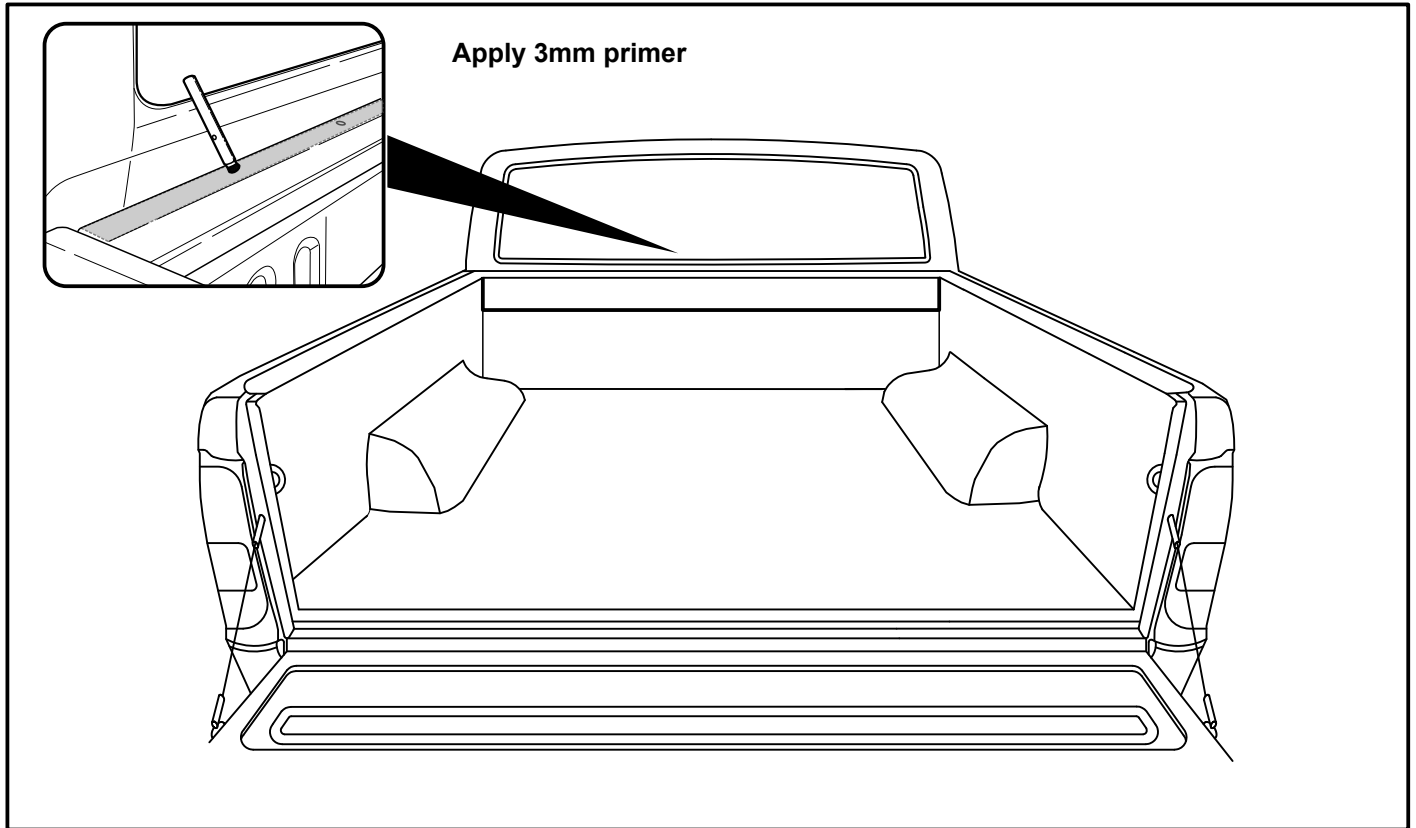

– STEP 18

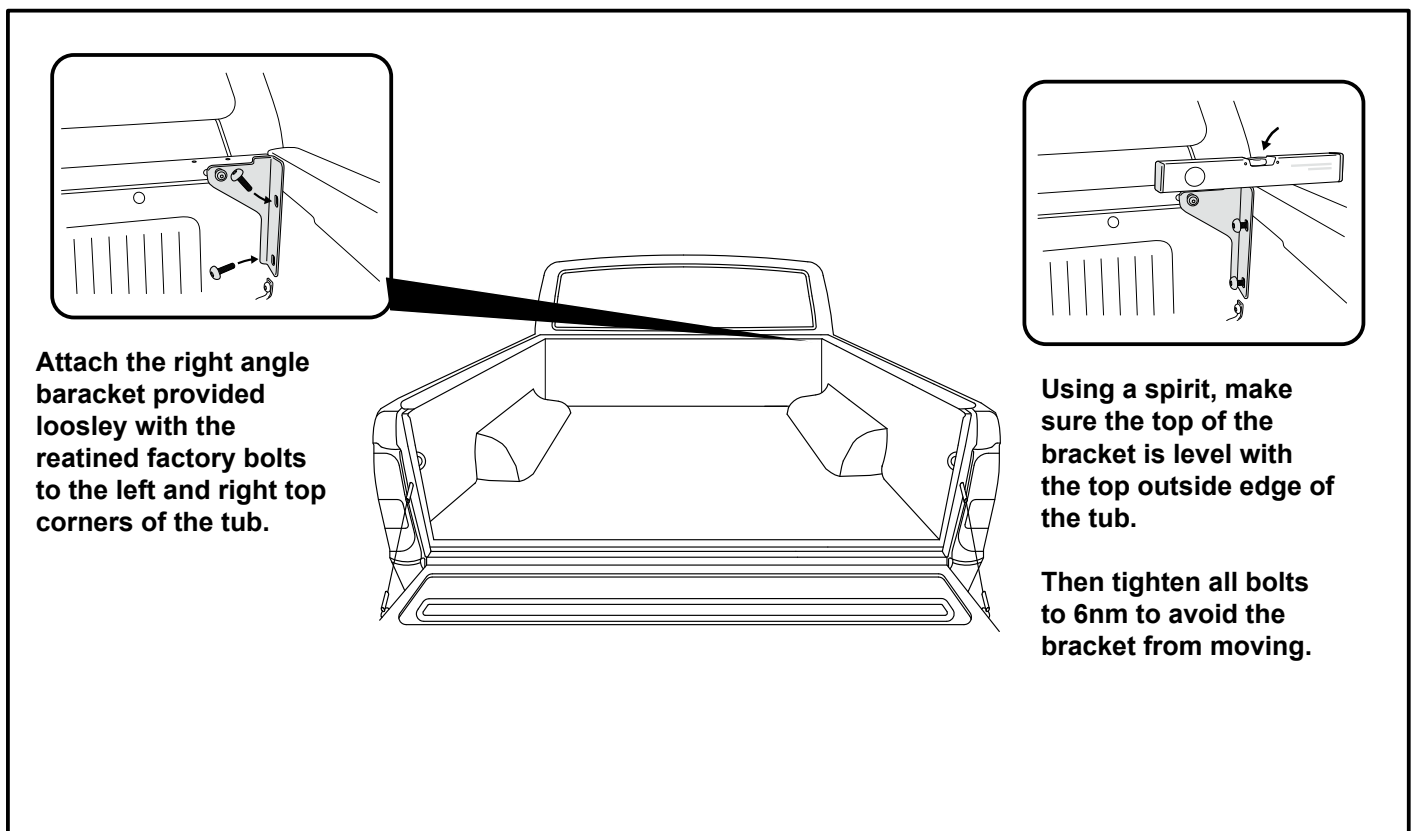

— Step 19 —

Installing the Roll-R-Cover

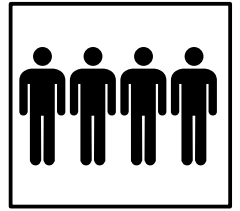
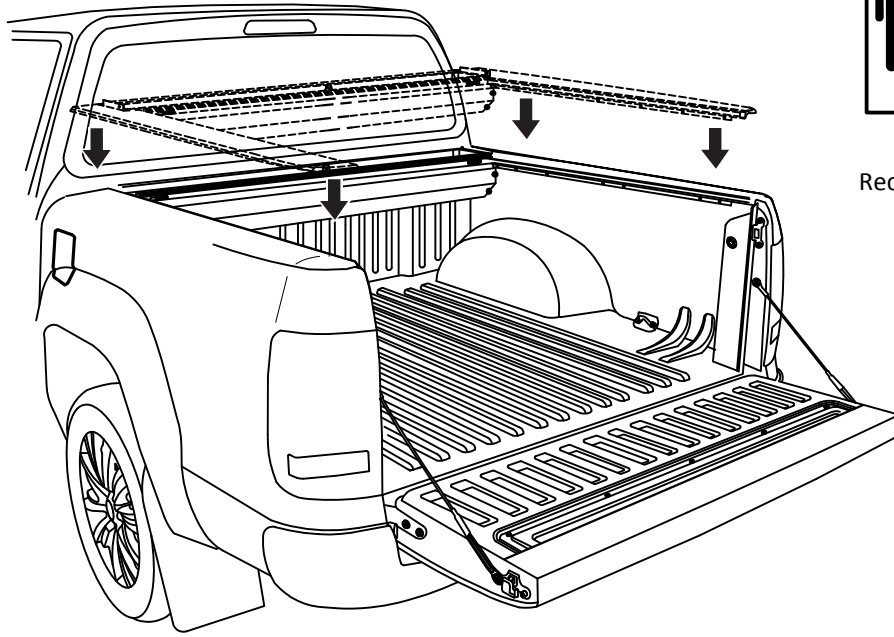

4 People
Recommended for lift

— Step 20 —

Before dropping the Roll R cover into place on the tub, connect all relevant connections or plugs to the receiver and motor plug connection.

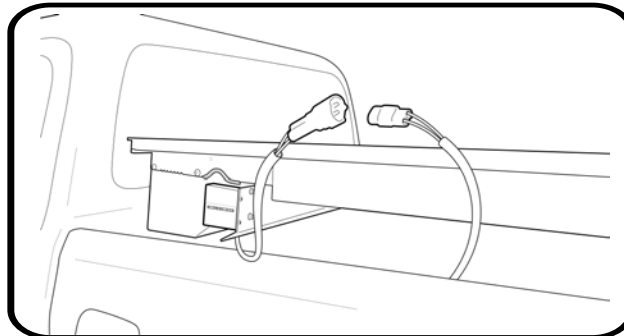
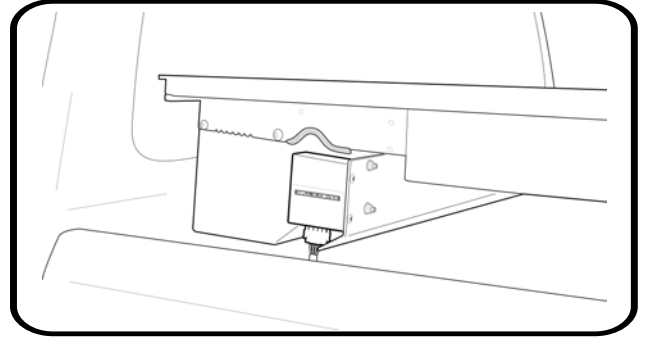
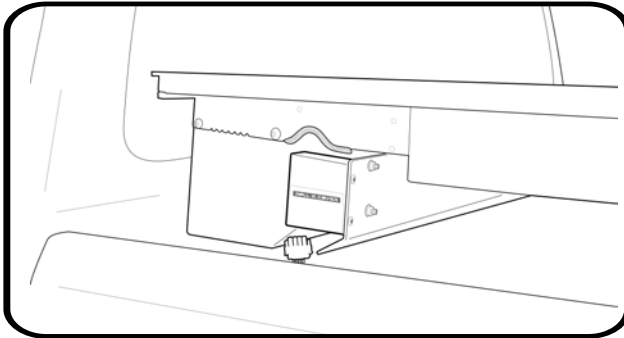

– Step 21

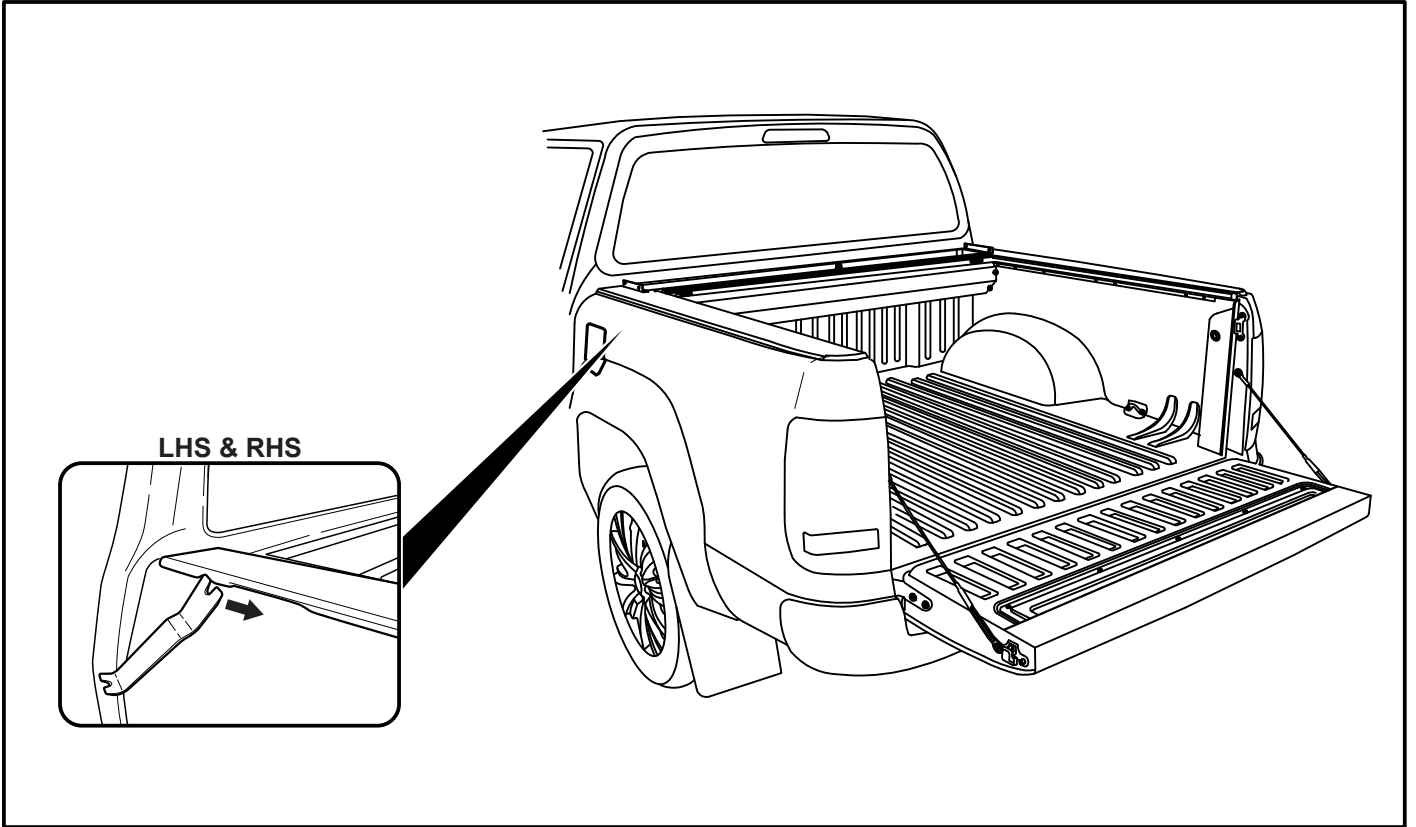

– Step 22

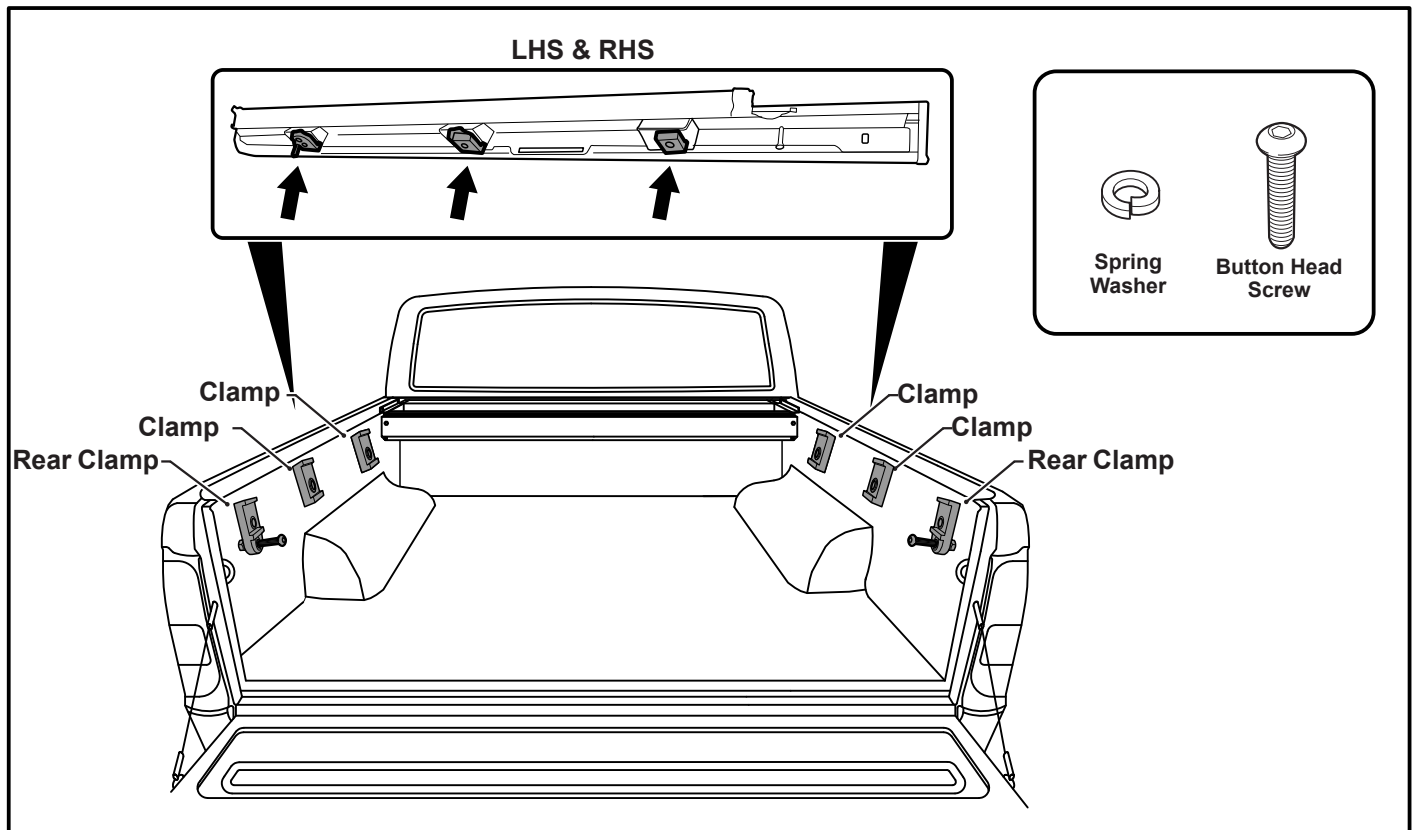

– Step 23

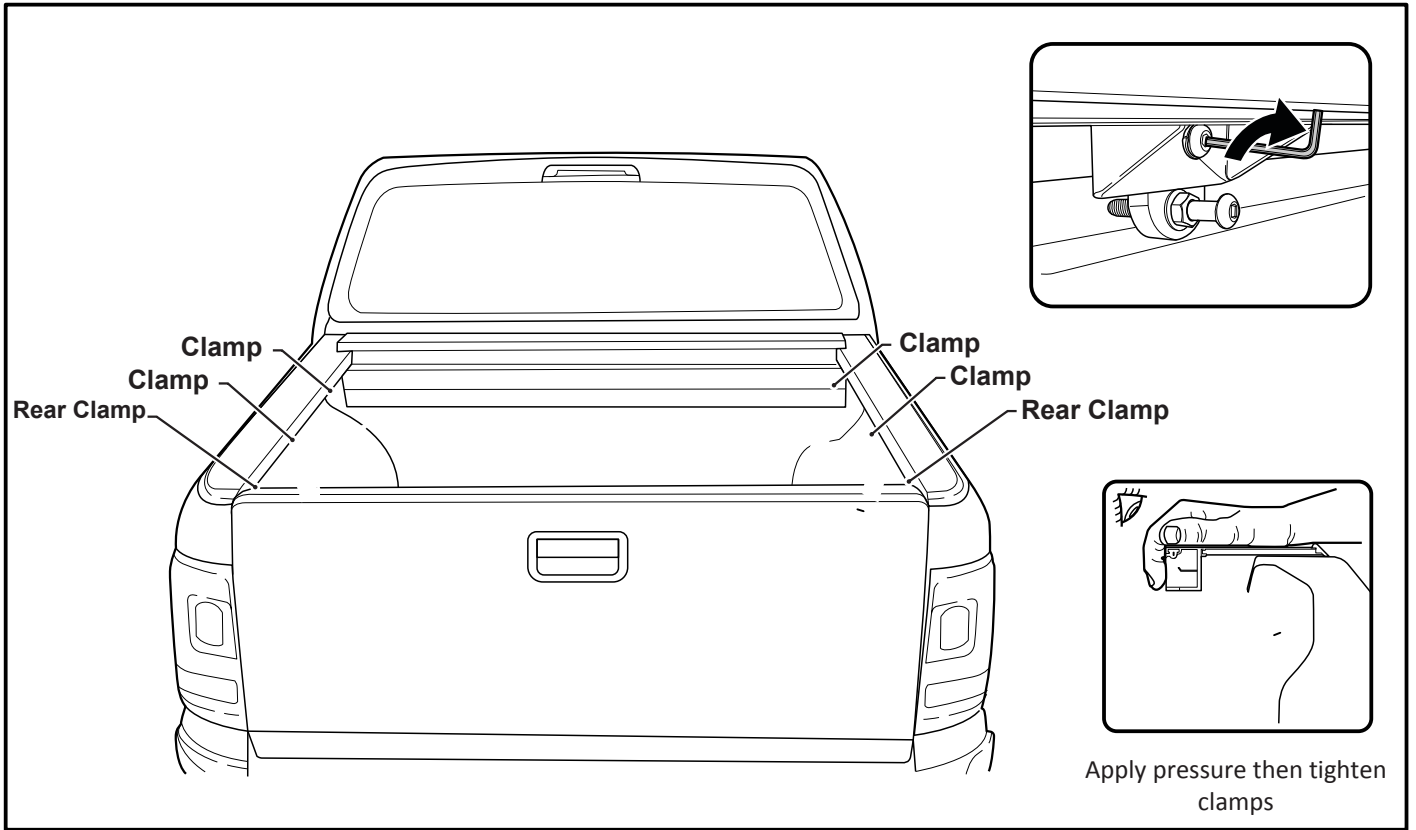

– Step 24

If curtain doesn't meet the tailgate in it's fully closed position, loosen the clamps and shift the unit back.

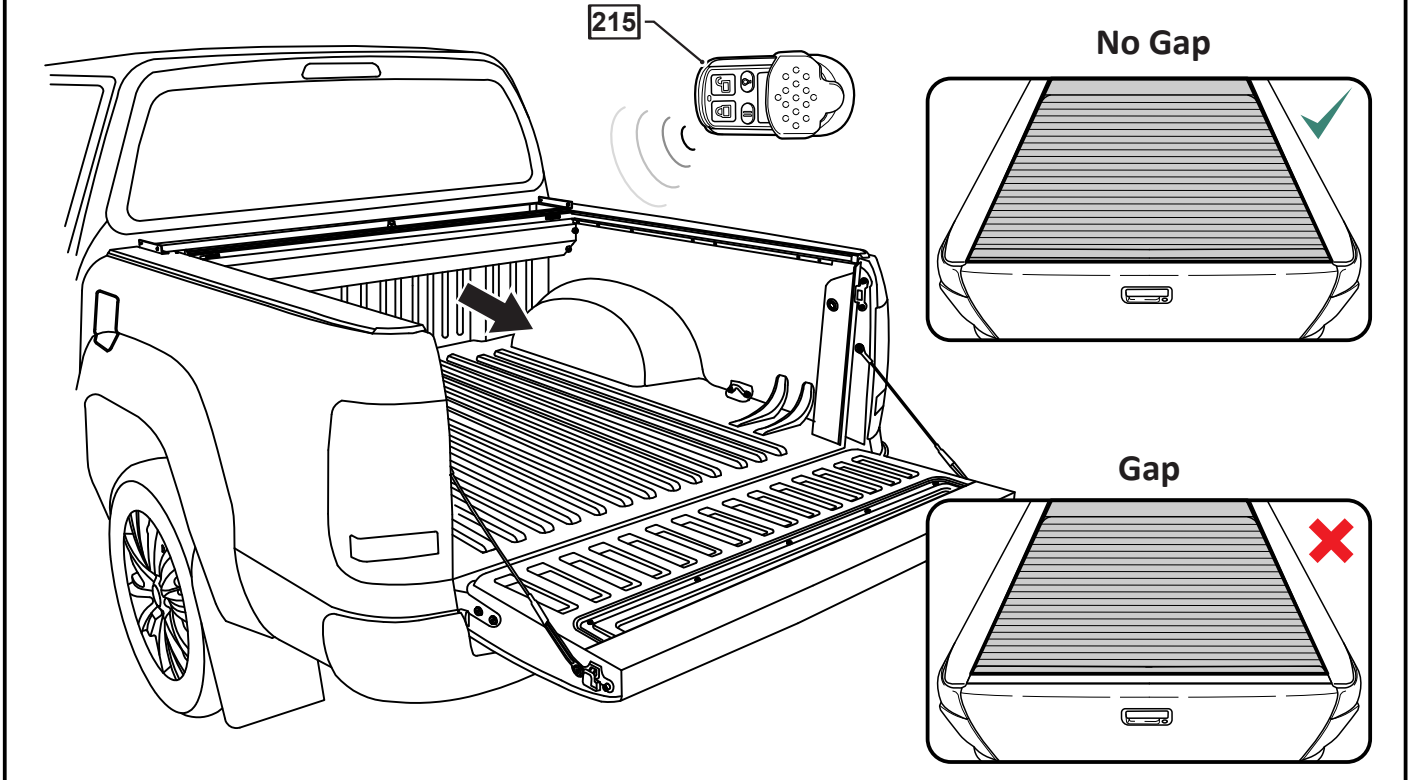

– Step 25

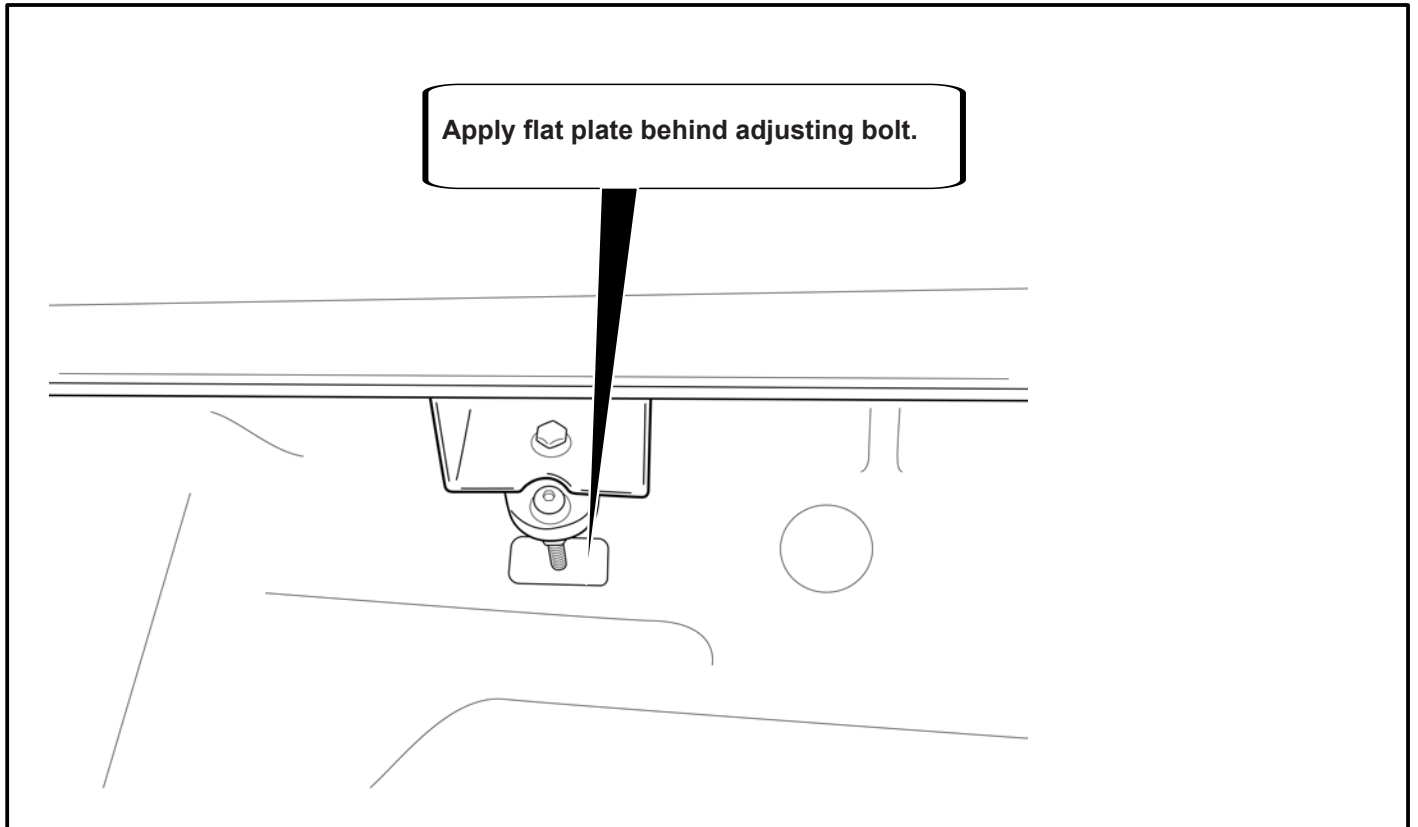

– Step 26

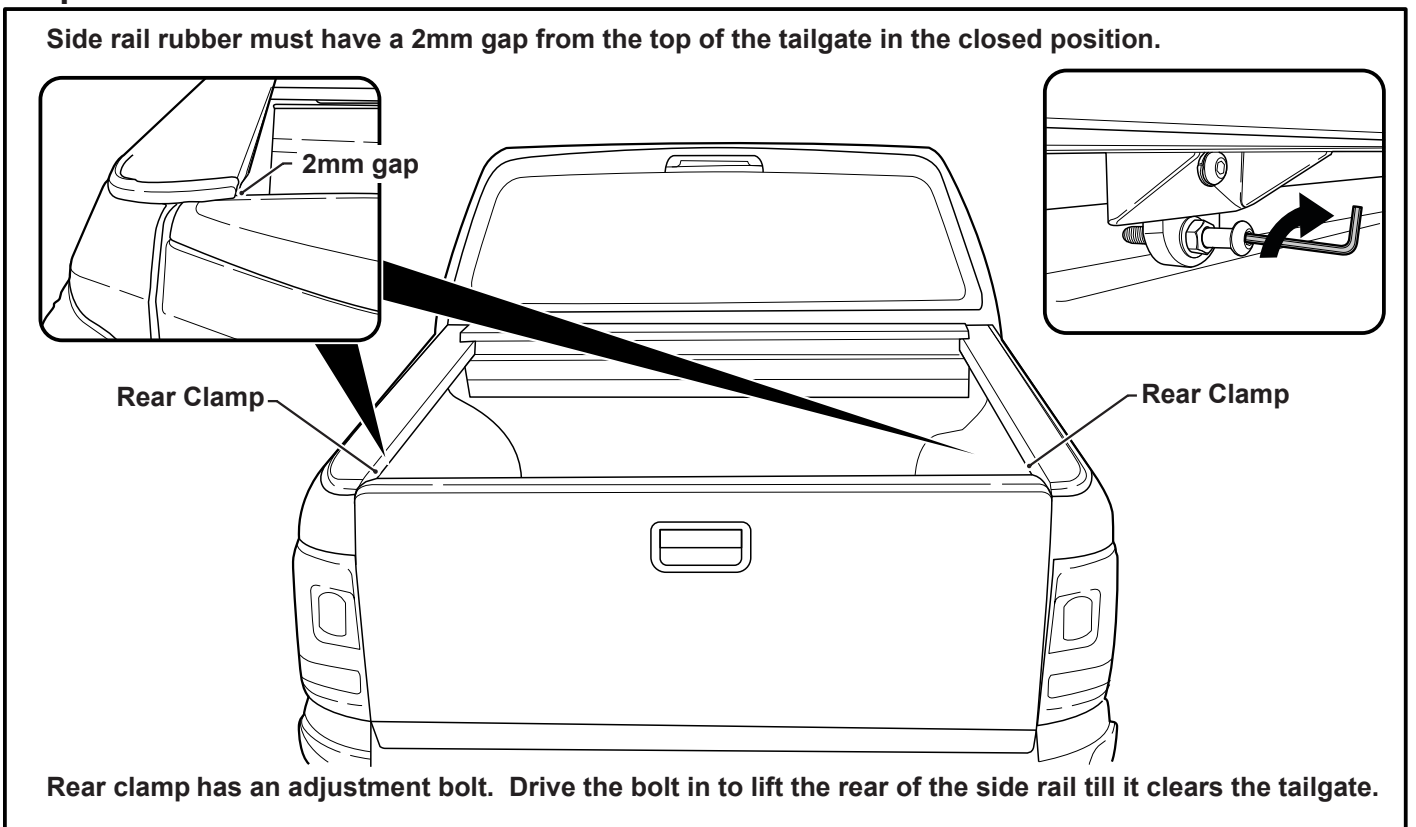

— Step 27 —

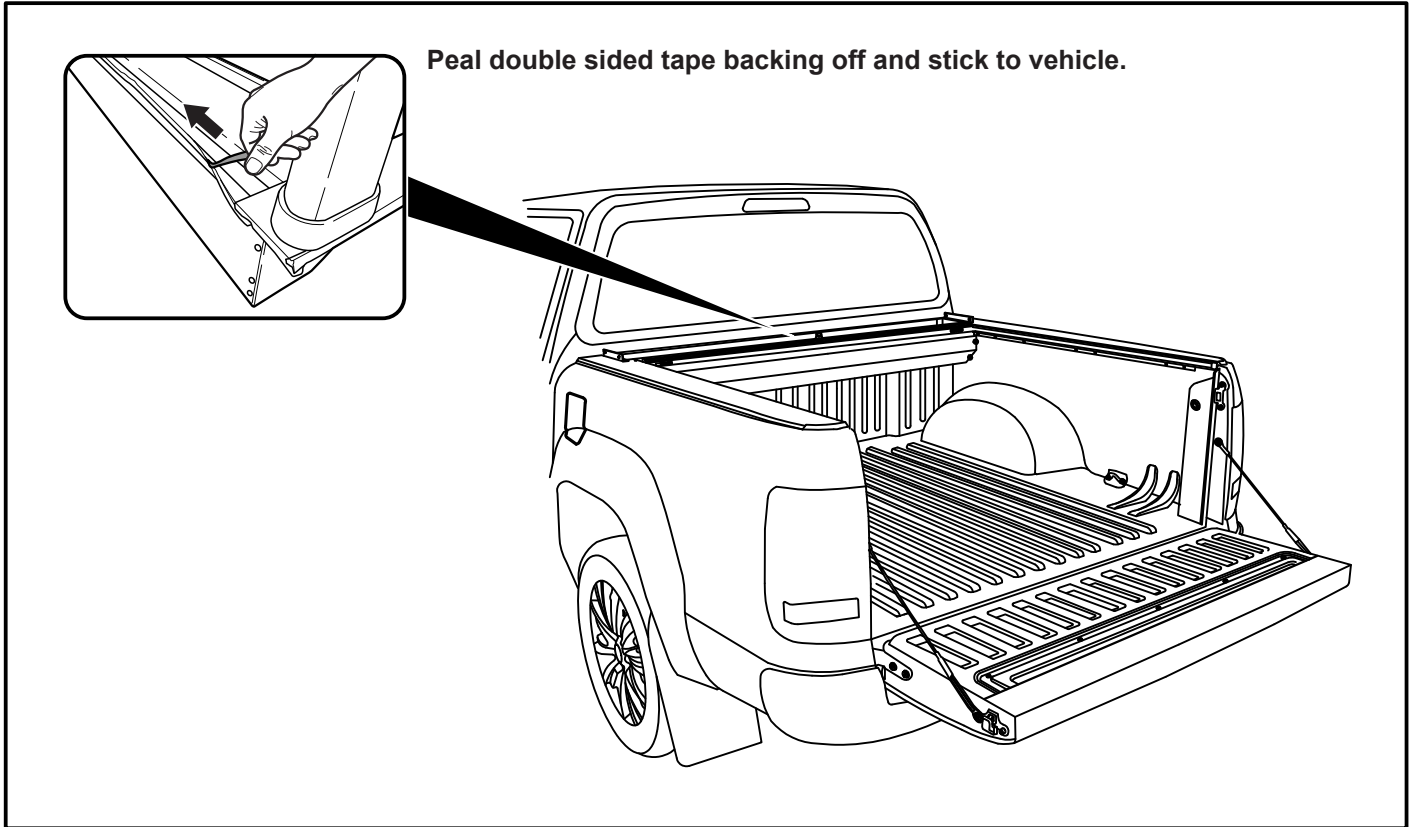

— Step 28 —

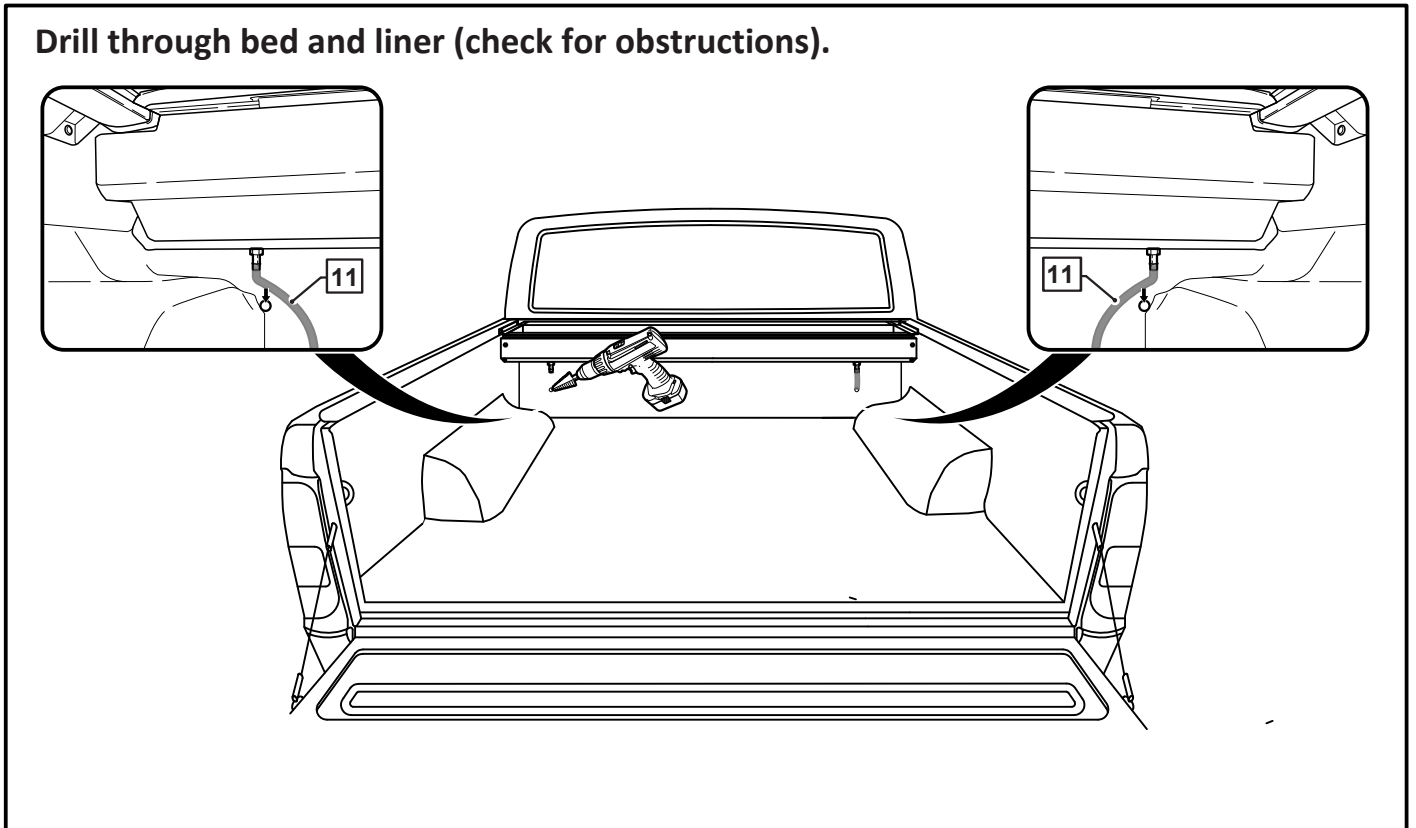

– Step 29

Remove the tail light to check for obstructions before drilling

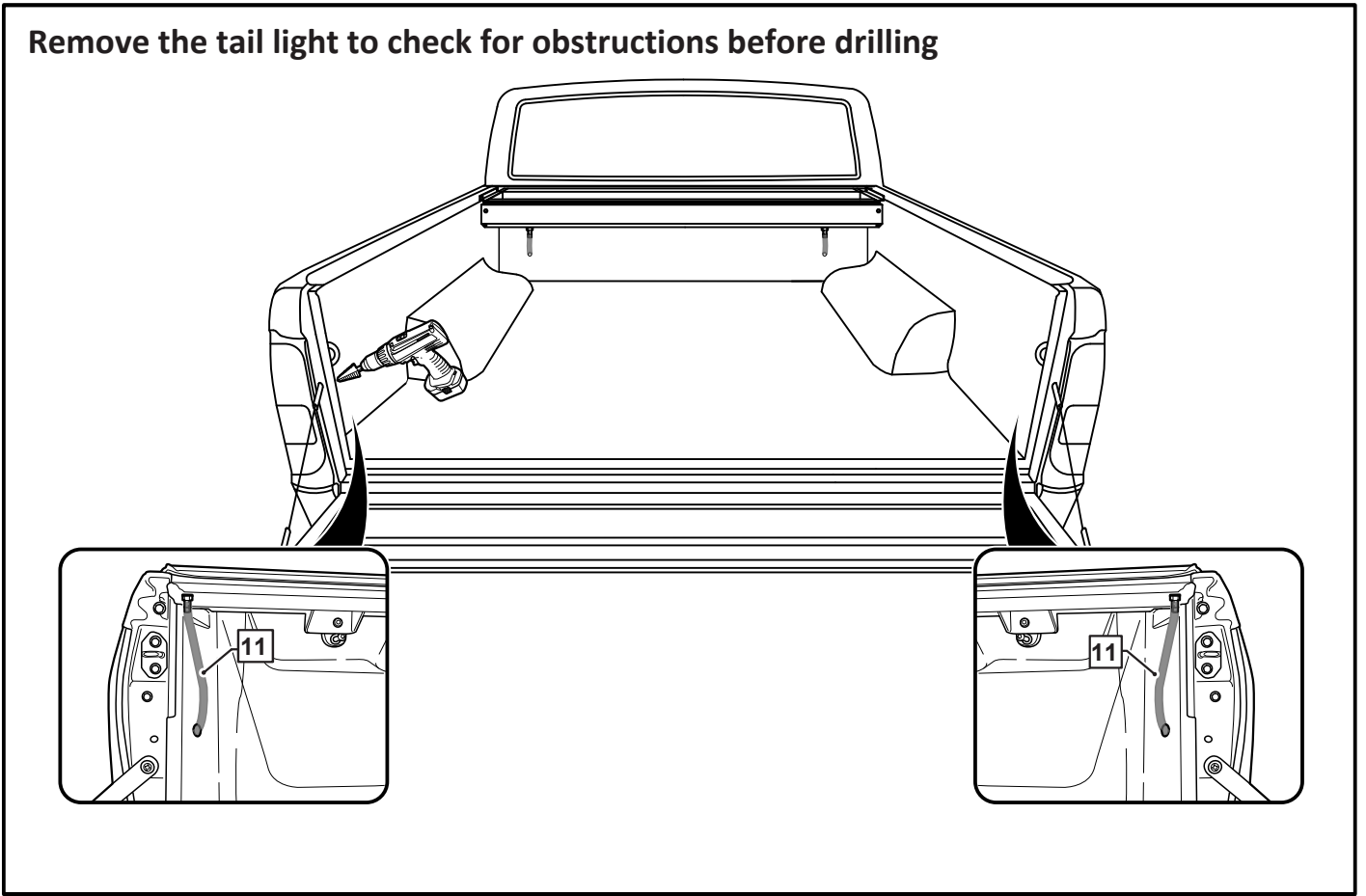

– Step 30

Snap fit the top cover.

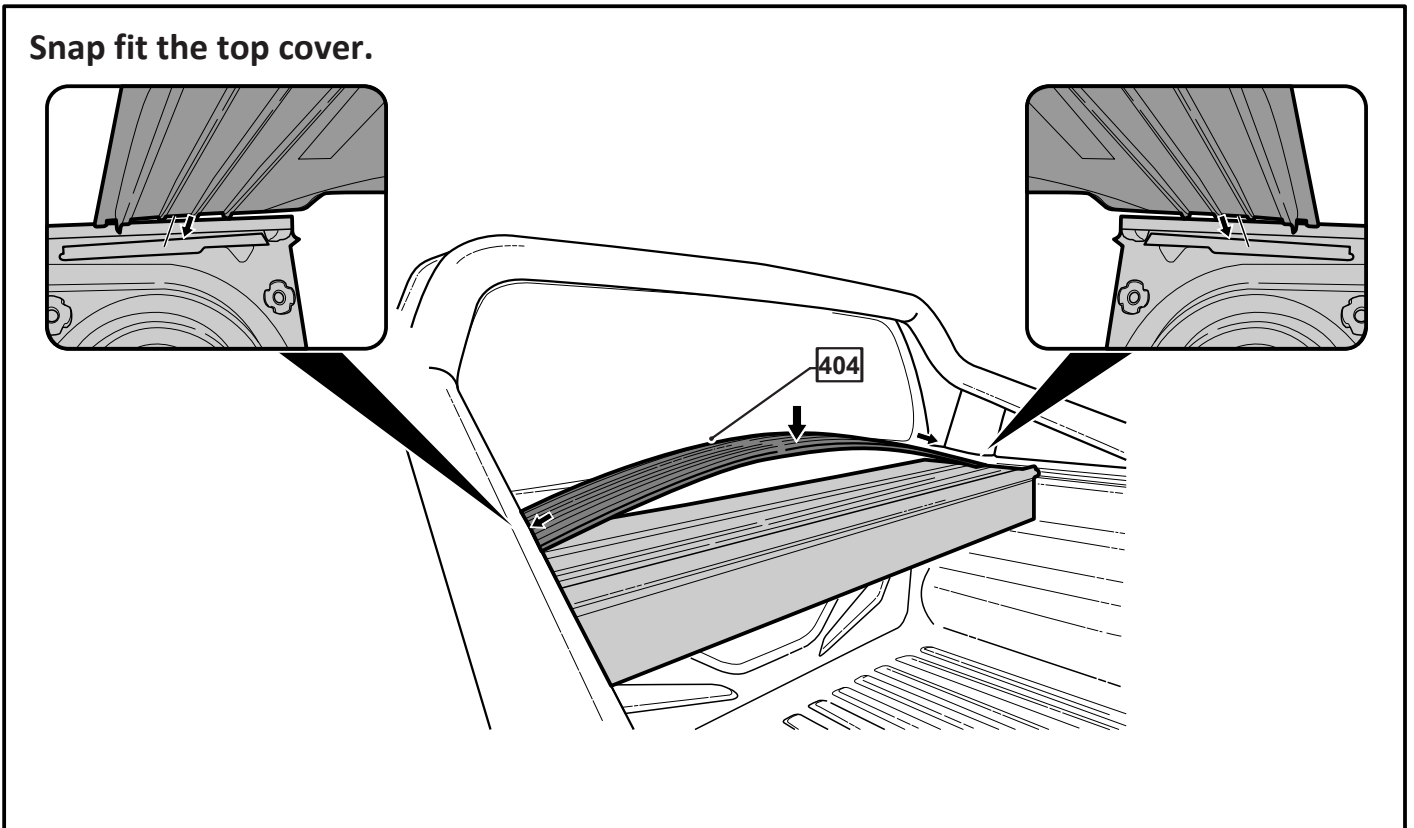

— Step 31 —

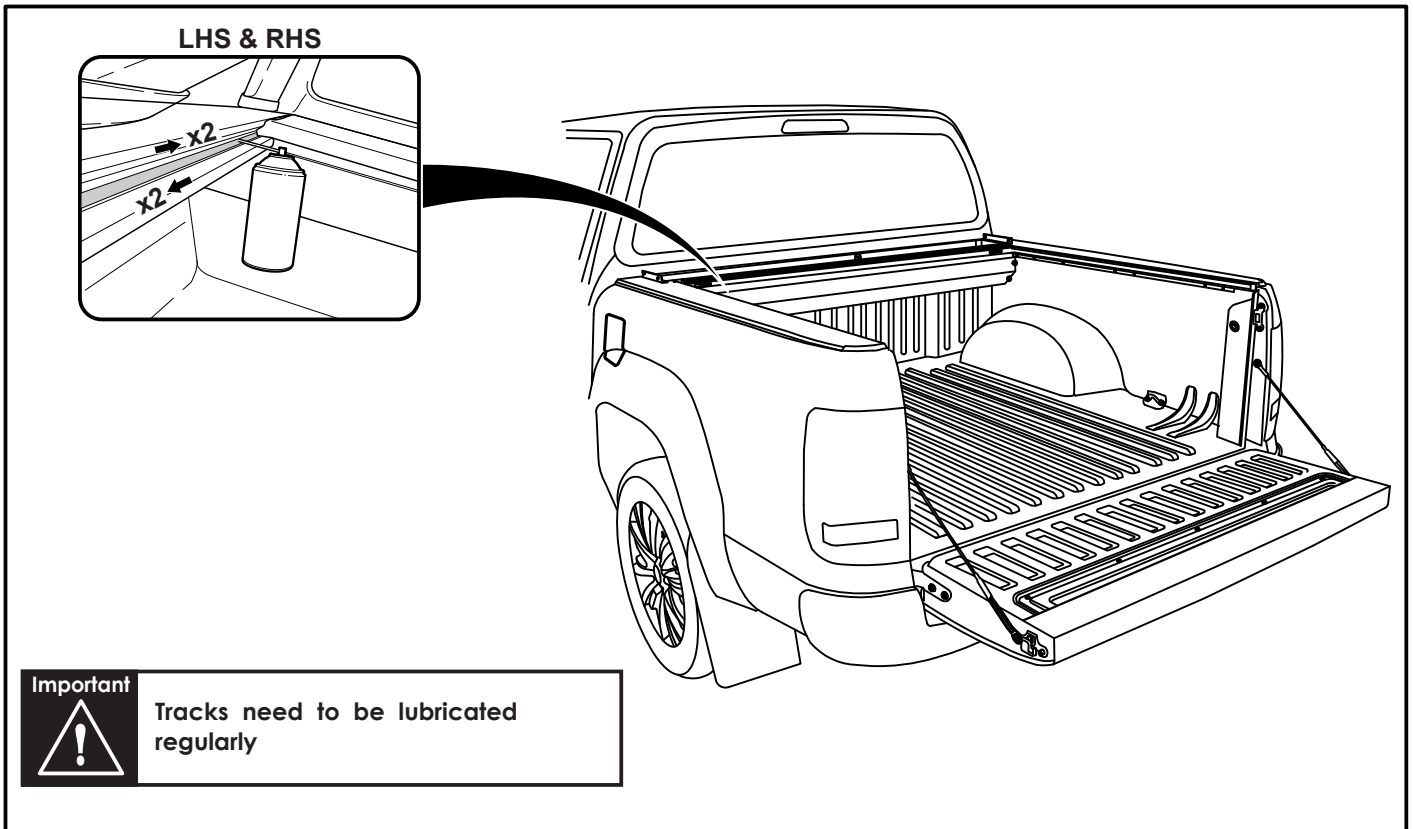

— Step 32 —

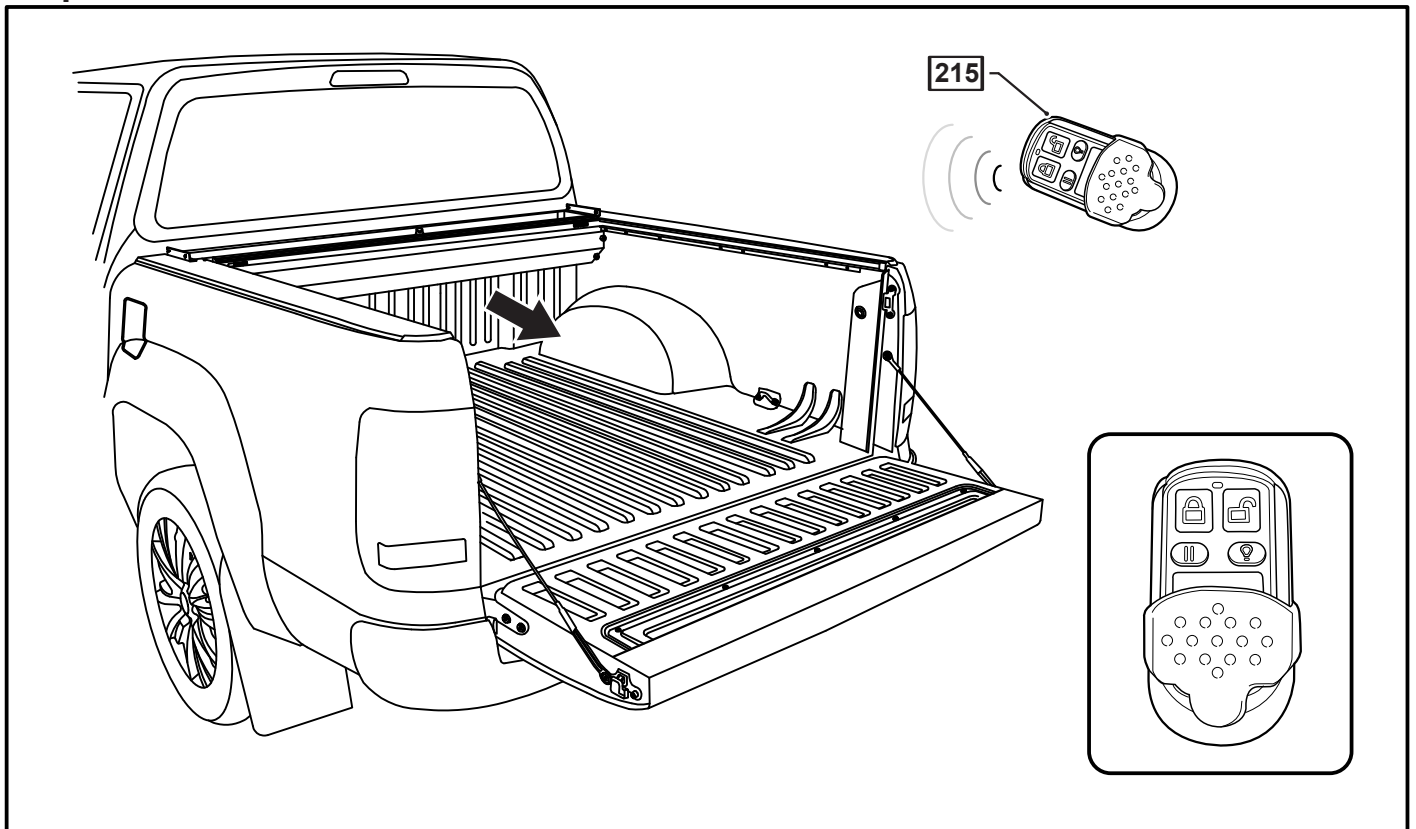

– Step 33

Important



You may open tailgate when Roll R Cover is in closed position, however you **MUST NOT** close the tailgate when Roll R Cover curtain is in the fully closed position.

WARNINGS!

www.hsputelids.com

 NO STANDING	ENSURE LOAD IS SECURE 	 CHECK GLIDES OIL REGULARLY	 CHECK CLAMPS AND TIGHTEN	 DO NOT PLACE LOAD ON COVER	CHECK DRAIN CLEAN CANISTER	 MECHANICAL HAZARD	NO PEOPLE OR ANIMALS UNDER ROLL TOP
------------------------	--	---	---	---	---	--------------------------------------	--

E. & O.E. This document is copyright and must not be used except as permitted below or under the Copyright Act 1968. You may reproduce and publish this document in whole or in part for your or your organisation's own personal or internal compliance, educational or non-commercial purposes. You must not alter or amend this document in any way. You must not reproduce or publish this document for commercial gain without the prior written consent of the copyright owner.