



WWW.HSPUTELIDS.COM

Part No: X5R

Fitting Time: 180 minutes

ROLL. R. COVER

To suit Isuzu Dmax Space Cab

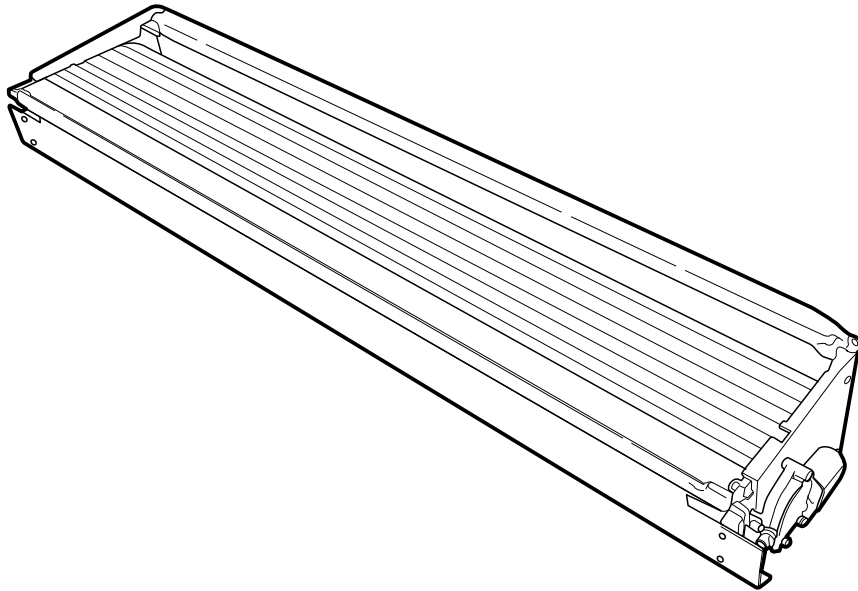

Roll-R-Cover

Fitting Instructions

– General Notes

- Read through the fitting instructions before installation of accessory.
- Always install the Roll R Cover Wiring Kit following the workshop manual and fitting instructions provided. Failure to do so may cause damage to the vehicle or the accessory.
- Ensure all recyclable components and packaging are discarded and recycled following local recycling regulations.
- It is always recommended that the Roll R Cover Wiring Kit is fitted by a qualified automotive technician.
- Safely store and protect any removed vehicle components.

– Safety Notes

- Check that all work practices comply with safety standards.
- Please wear appropriate clothing and use safety equipment.



– Fitting Time



180 minutes

– Parts Supplied

X5R	EXTRA CAB ISUZU D'MAX - ROLL R COVER		
PART DESCRIPTION	PART NUMBER	QUANTITY/LENGTH	CHECK
X5R FITTING INSTRUCTIONS	389*	1	
LUBRICANT PUMP SPRAY	47*	1	
REMOTE	215*	2	
PRIMER STICK	44*	1	
CABLE TIE 4.8X300MM	217*	10	
ROLL R LOOM	216*	1	
X5R CANISTER AND CURTAIN	425*	1	
X5R RAIL RIGHTHAND	347*	1	
X5R RAIL LEFTHAND	348*	1	
BLACK NITRILE FOAM 6MMX25MMX1.6M	391	1	
HOSE 600MM	11*	4	
COMPLETE CANISTER COVER	406	1	
OPERATION LEAFLET	66	1	
MAINTENANCE LEAFLET	67	1	
ADJUSTMENT PLATES	31	2	
BLACK PUTTY	3*	8	

**The following steps are for vehicles with bed liners.
If there are no bed liners installed move to Step 4**

– Step 1

Trim front of bed liner by 180mm from the top of the ute bed as shown.

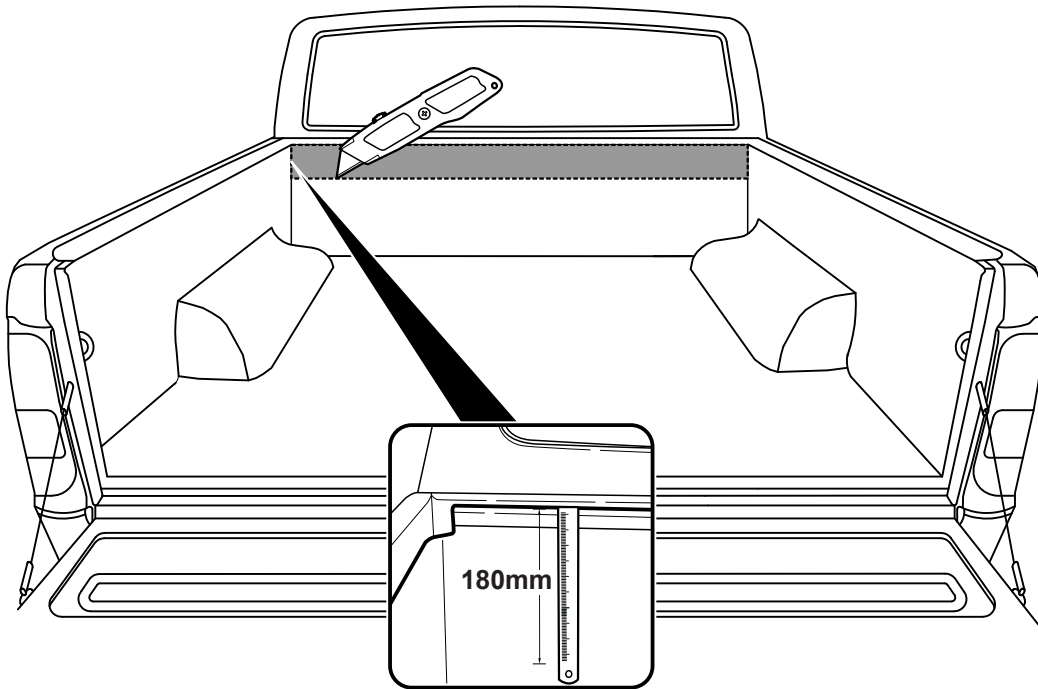

– Step 2

Cut a 20mm split for bed liner to flex.

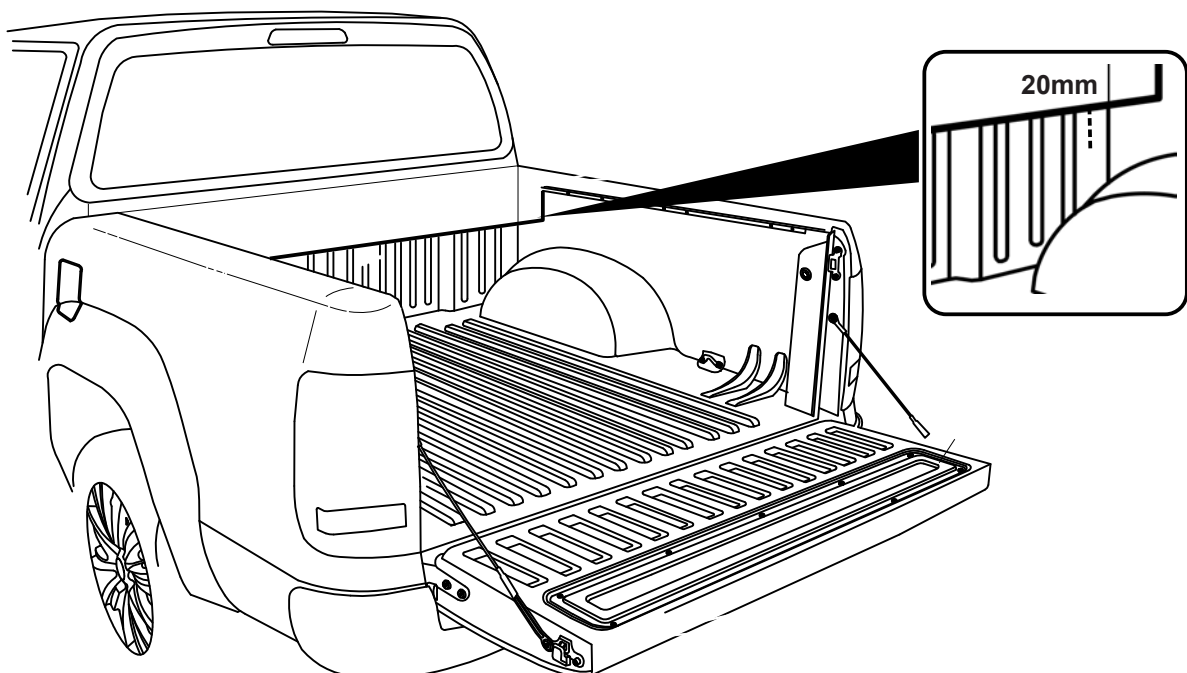

— Step 3 —

Measure 20mm down from top of tailgate and trim tailgate liner.

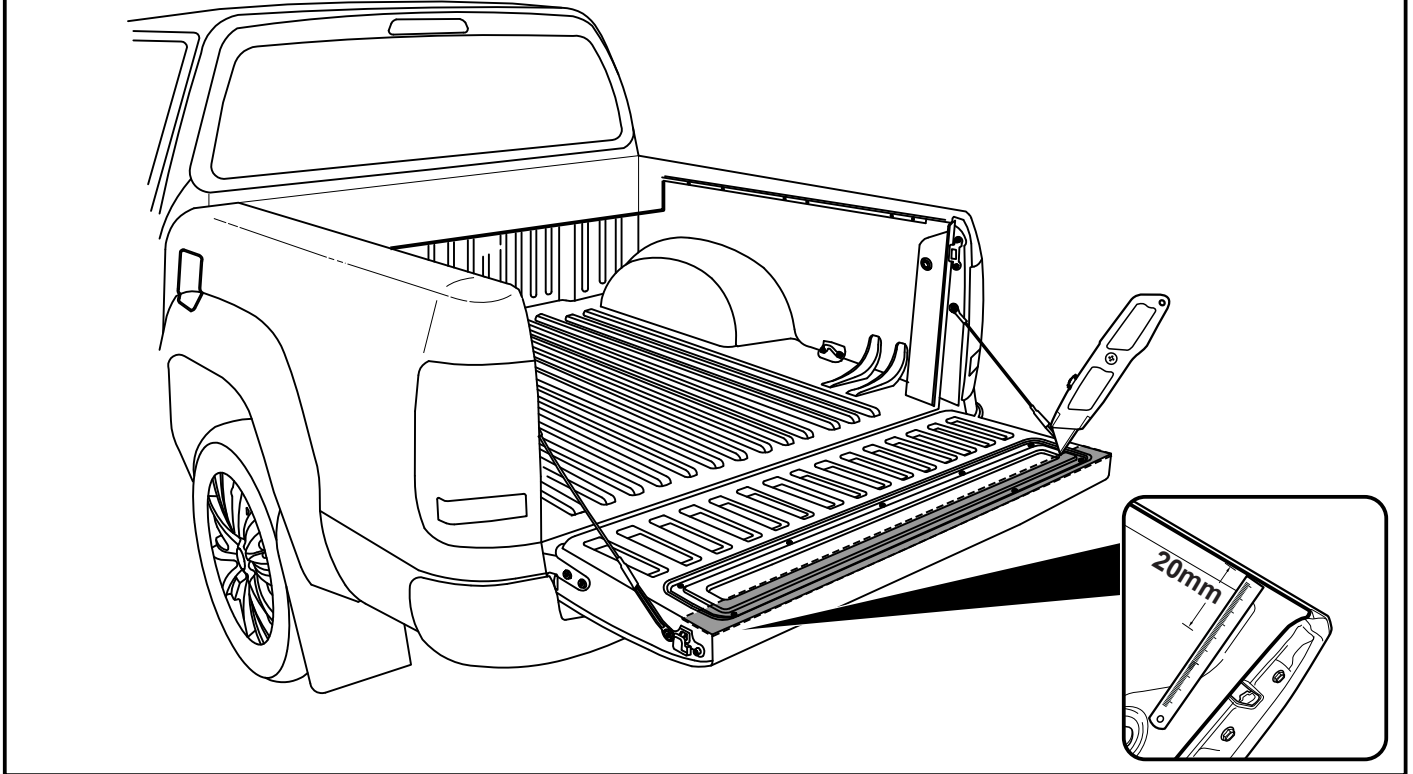

— Step 4 —

Roll-R-Cover preparation steps

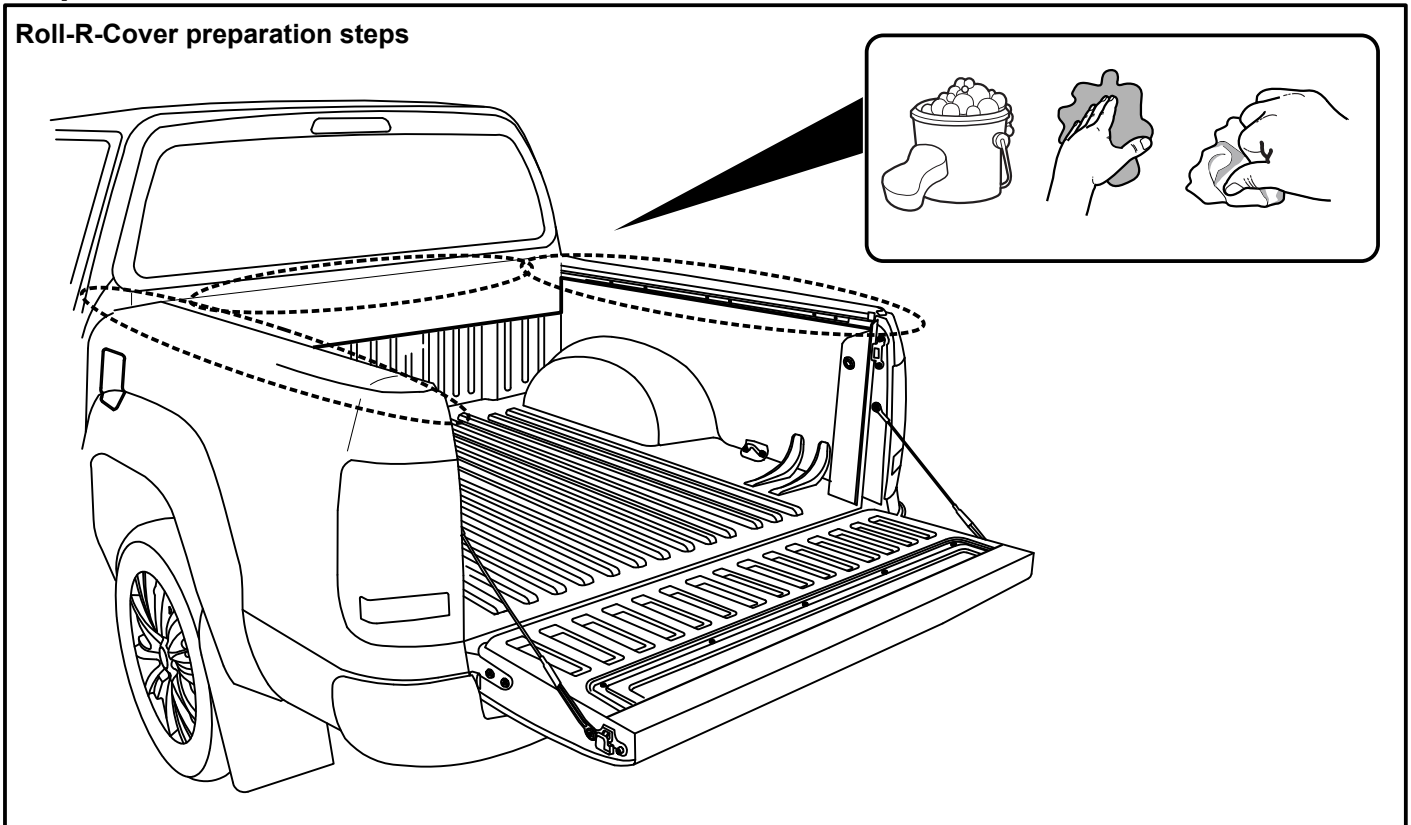

– Step 5

Carefully unpack the box.

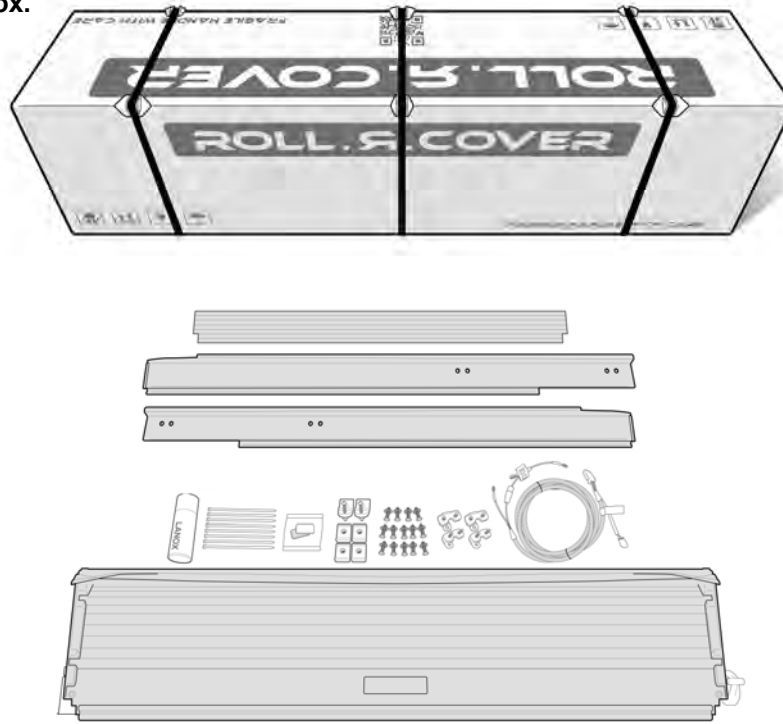

– Step 6

Wiring Harness steps

1 Feed through the cavity

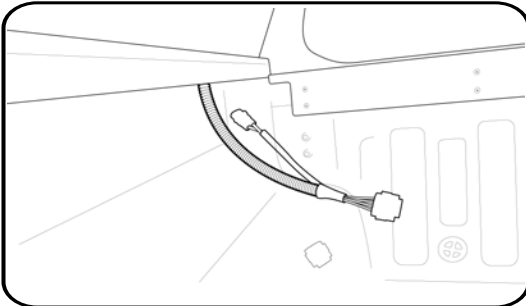

3

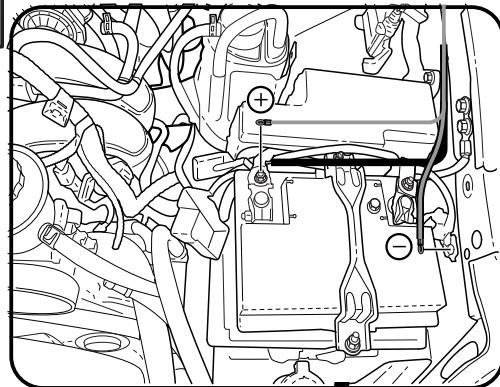

2

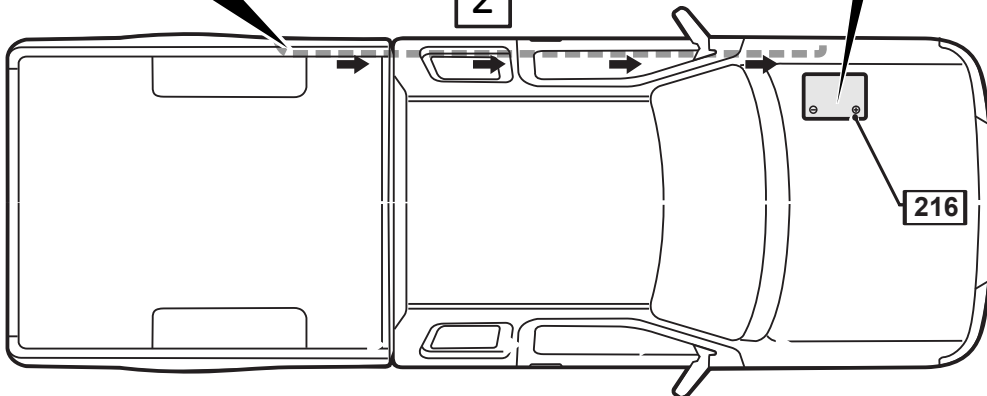

Run the wiring from the front corner cavity to the battery over the chassis rail. Making sure to keep away from hot obstructions and cable tie every 400mm.

– Step 7

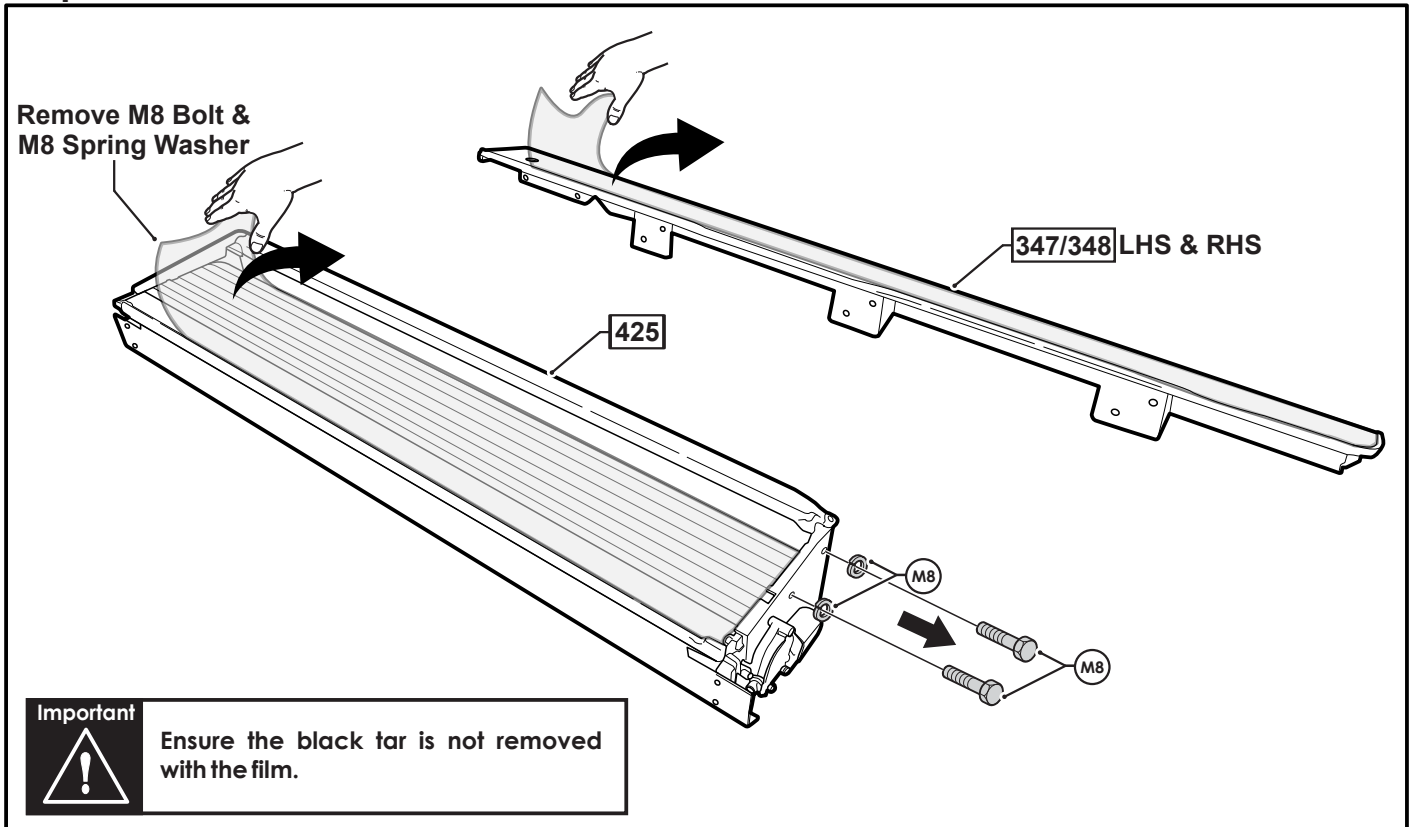

– Step 8

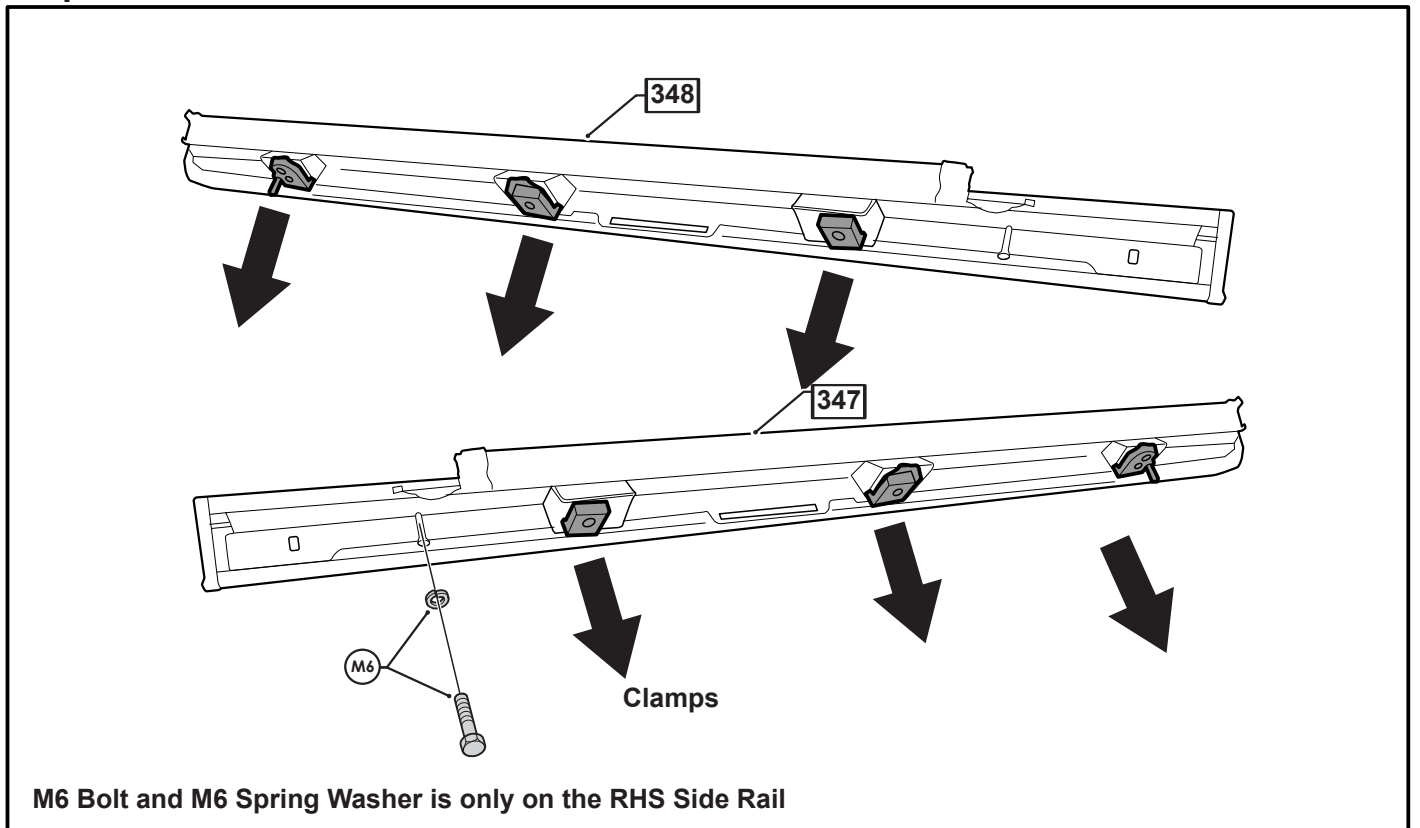

— Step 9

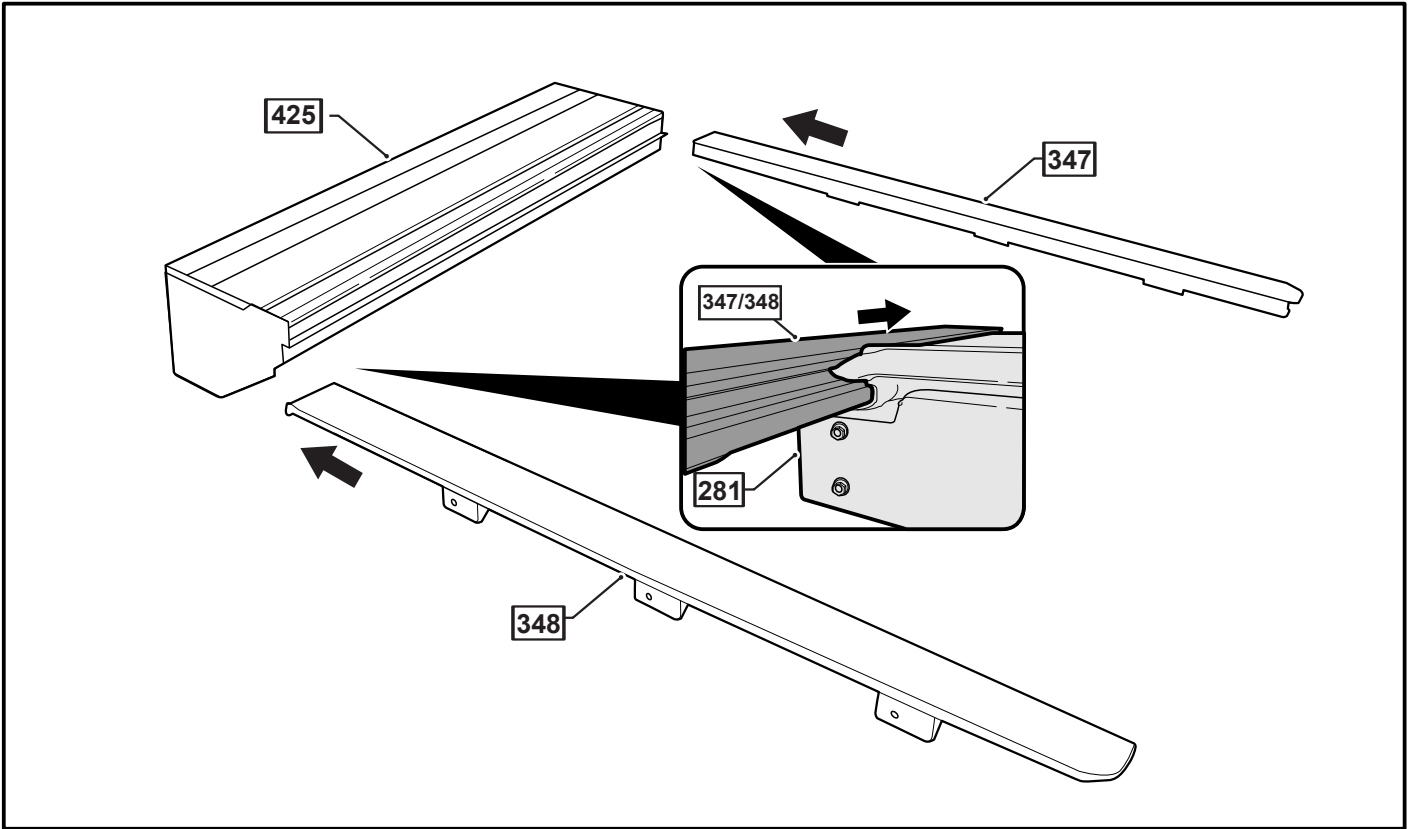

— Step 10

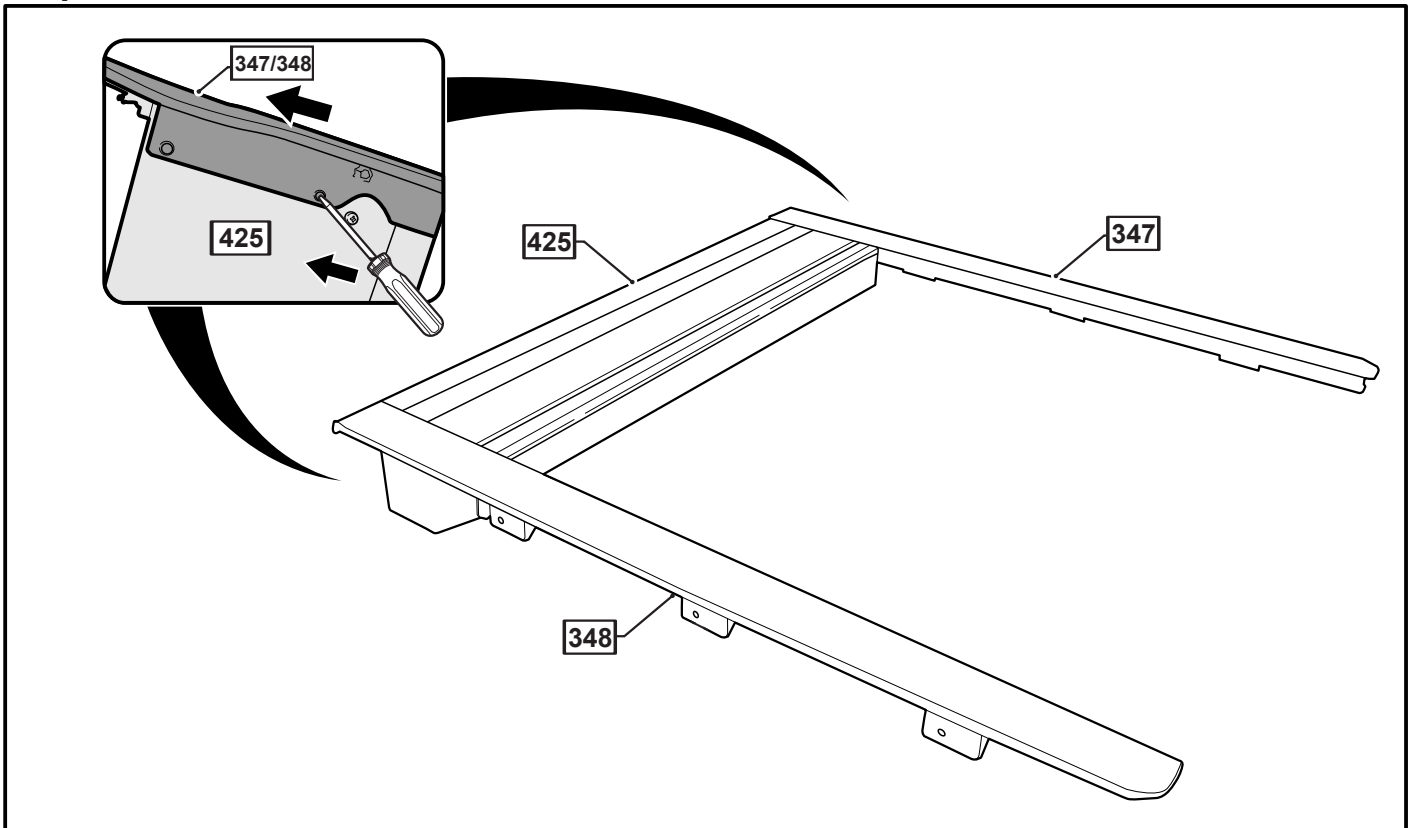

– Step 11

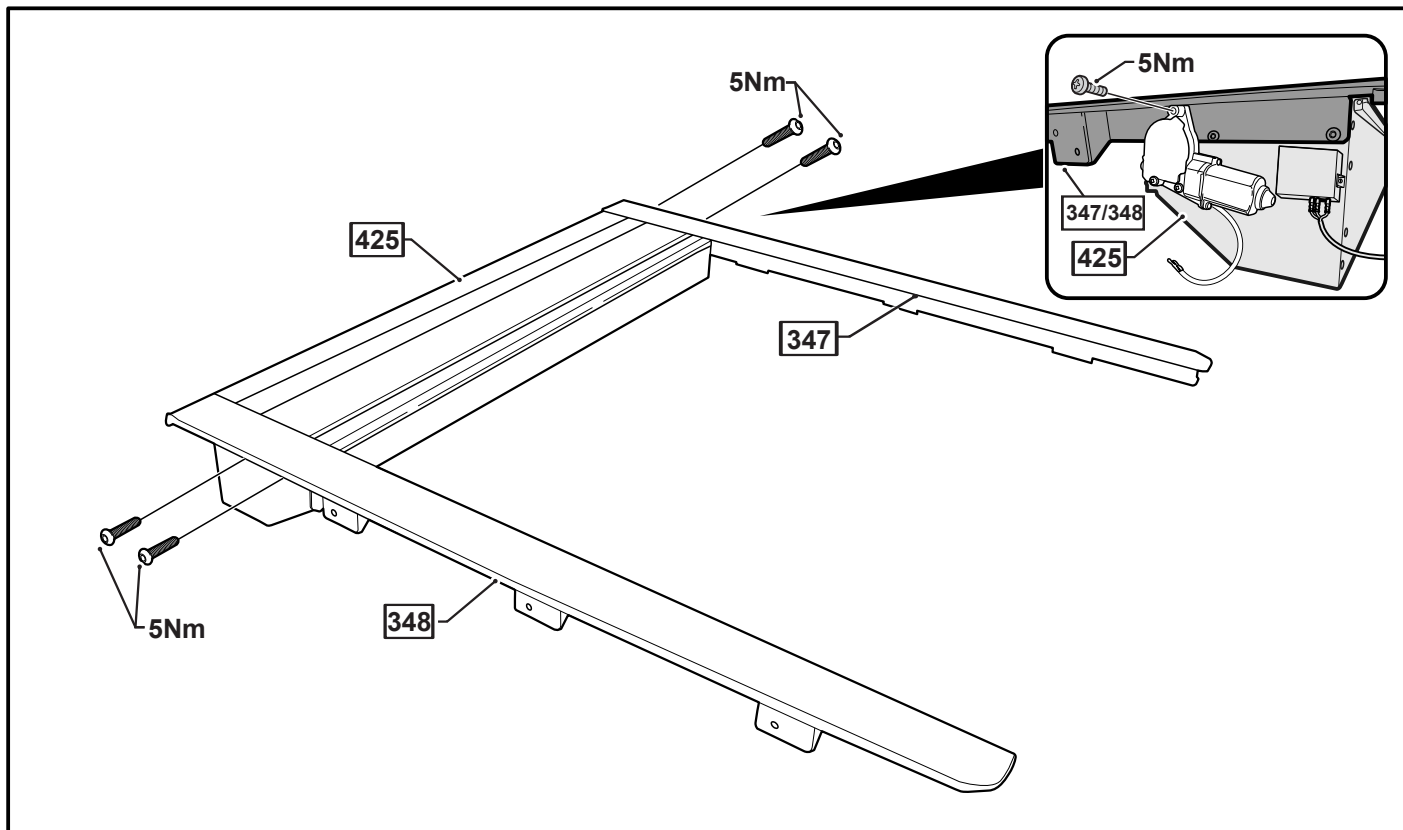

– Step 12

Apply tar sealant to the gap under water channel.

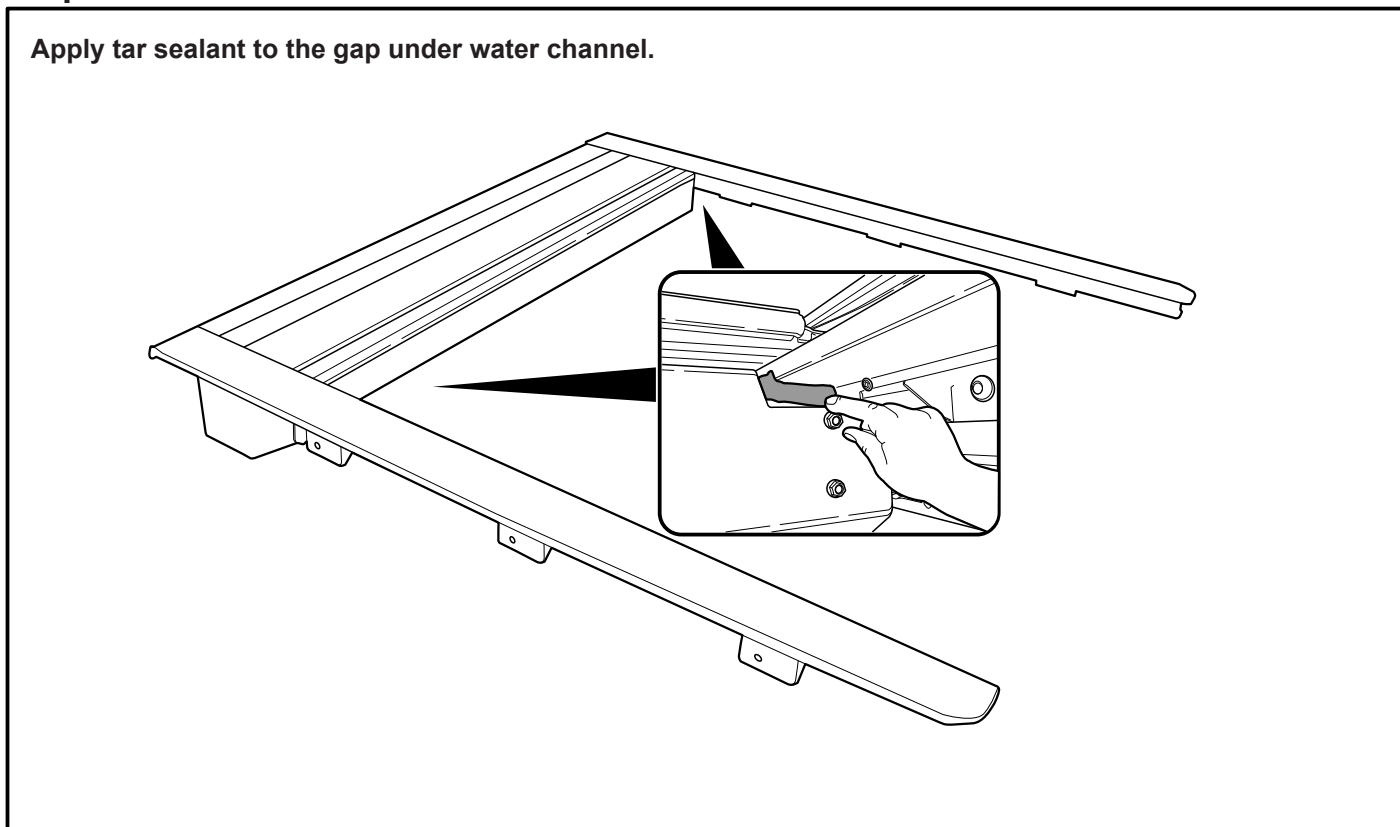

– Step 13

Apply tar sealant to both sides of the canister as shown (where accessible).

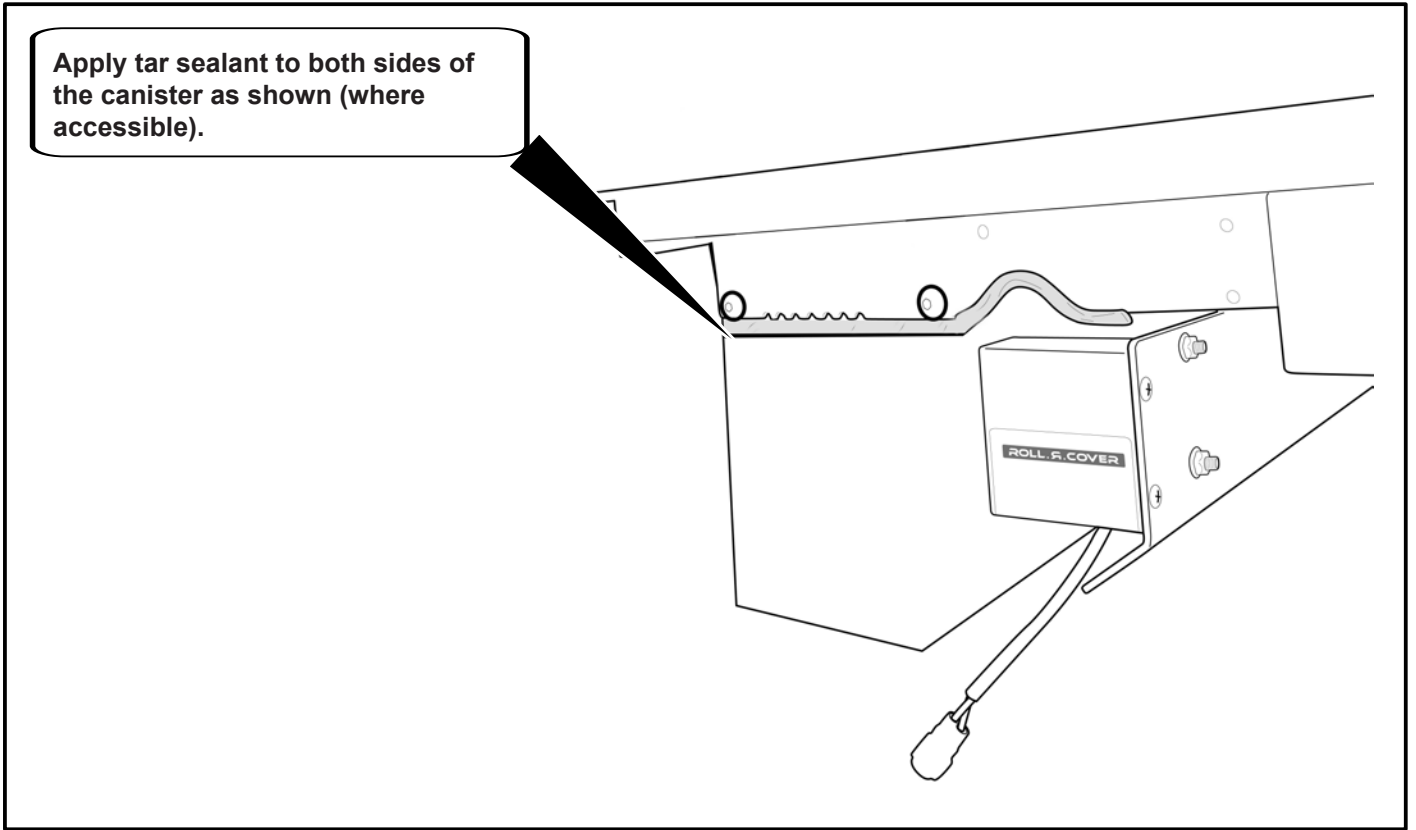

– Step 14

Run foam seal provided along the front of the tub to make headrail level with sides.

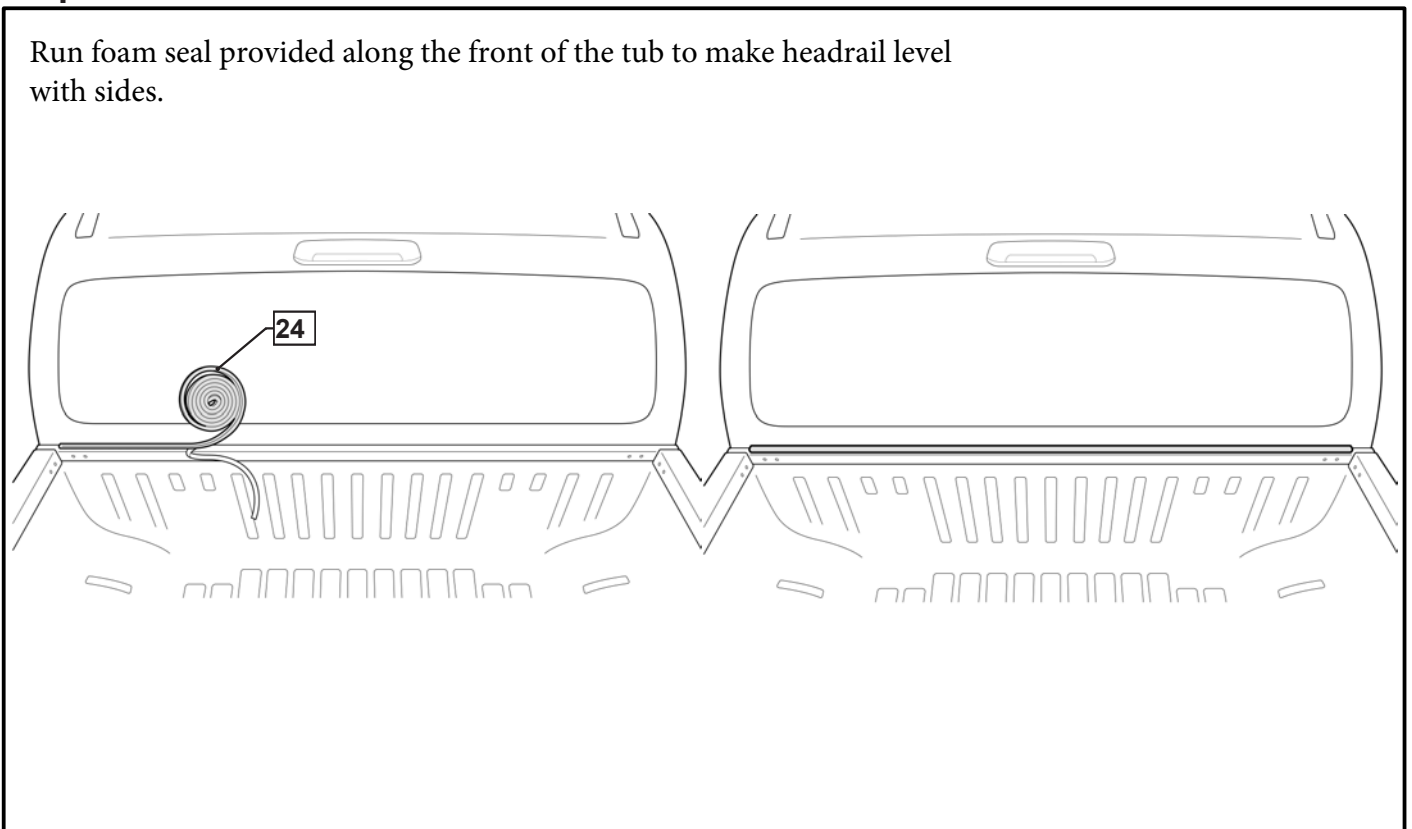

– Step 15

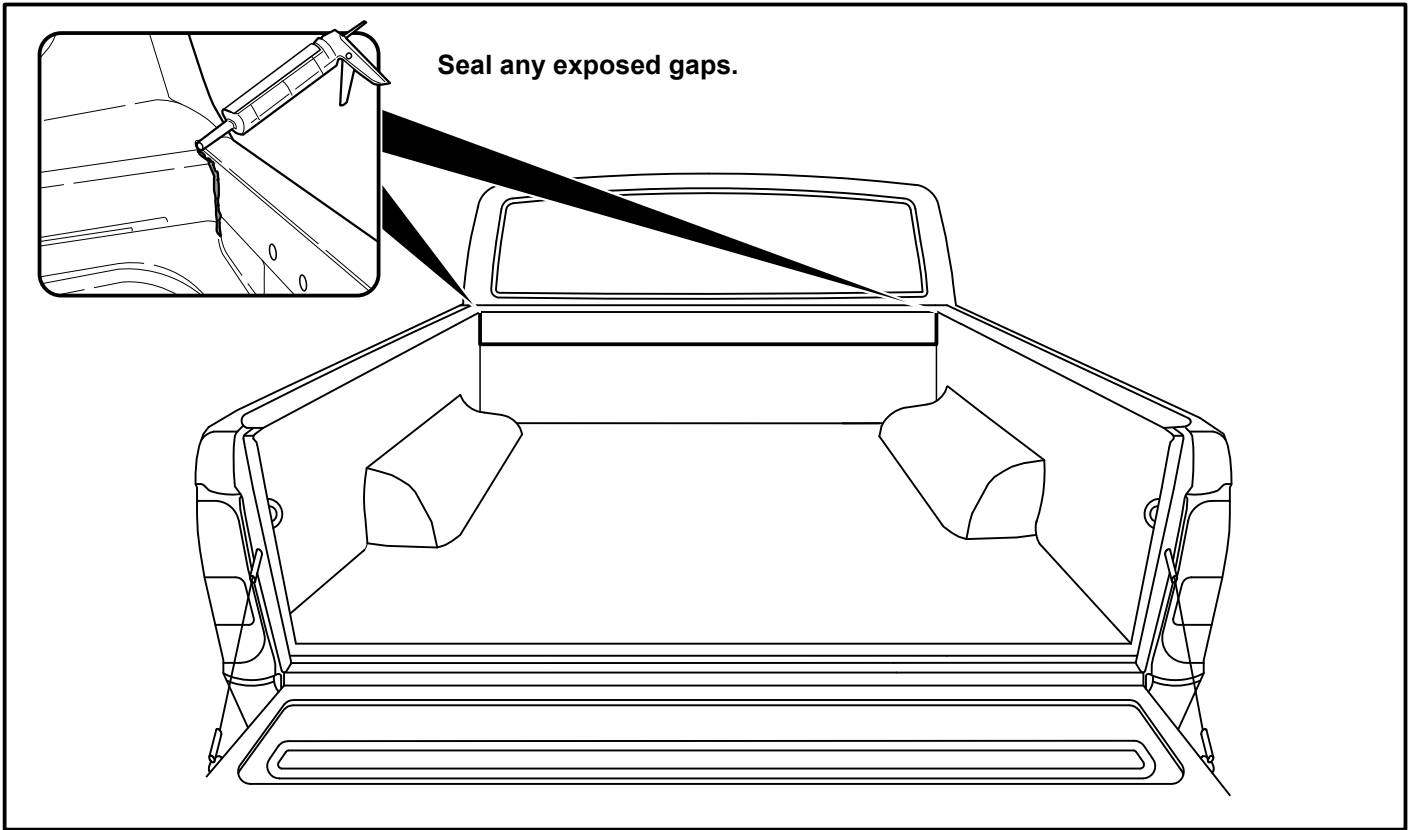

– Step 16

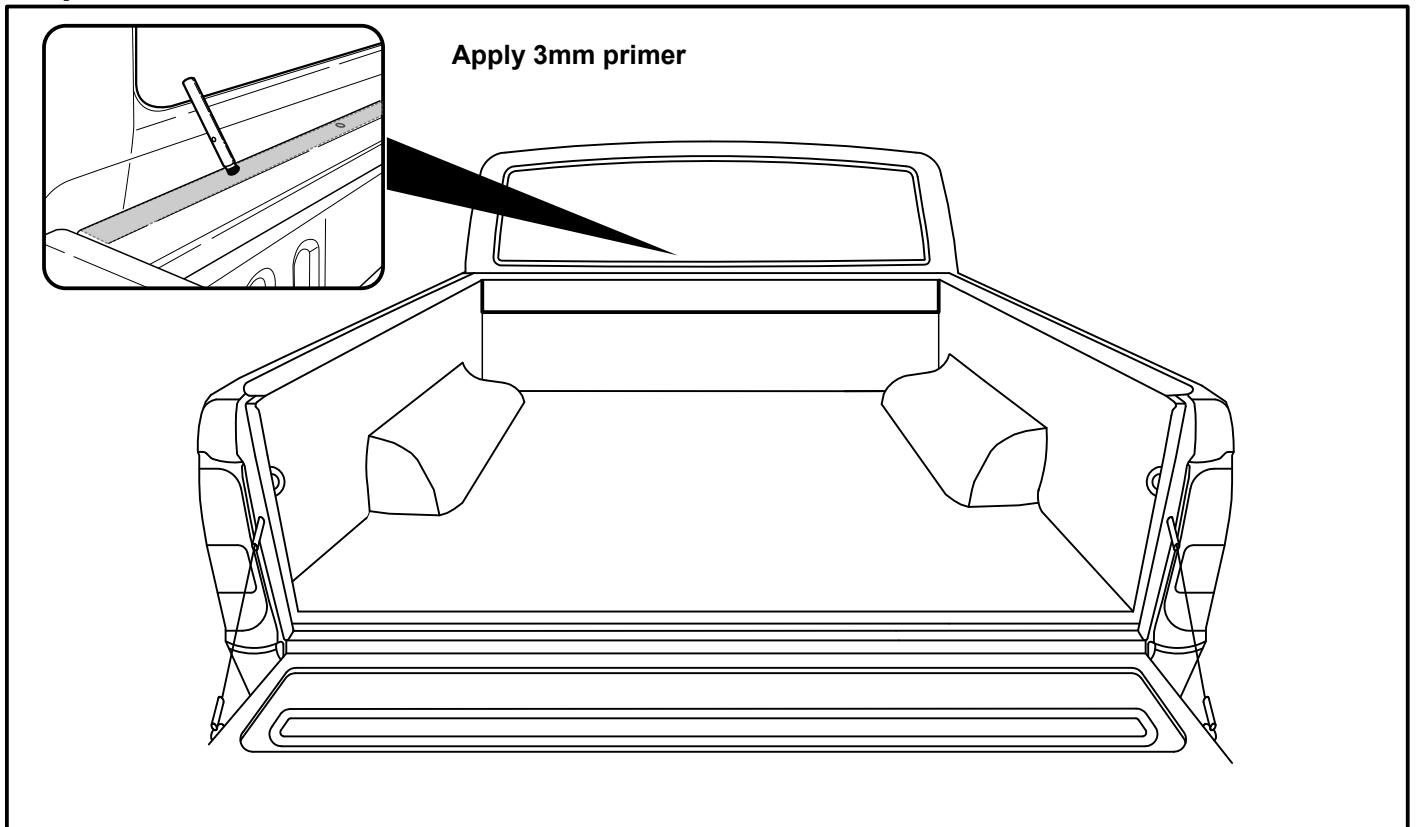

— Step 17 —

Installing the Roll-R-Cover

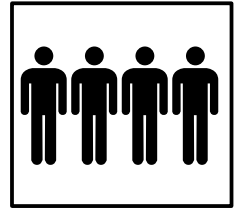
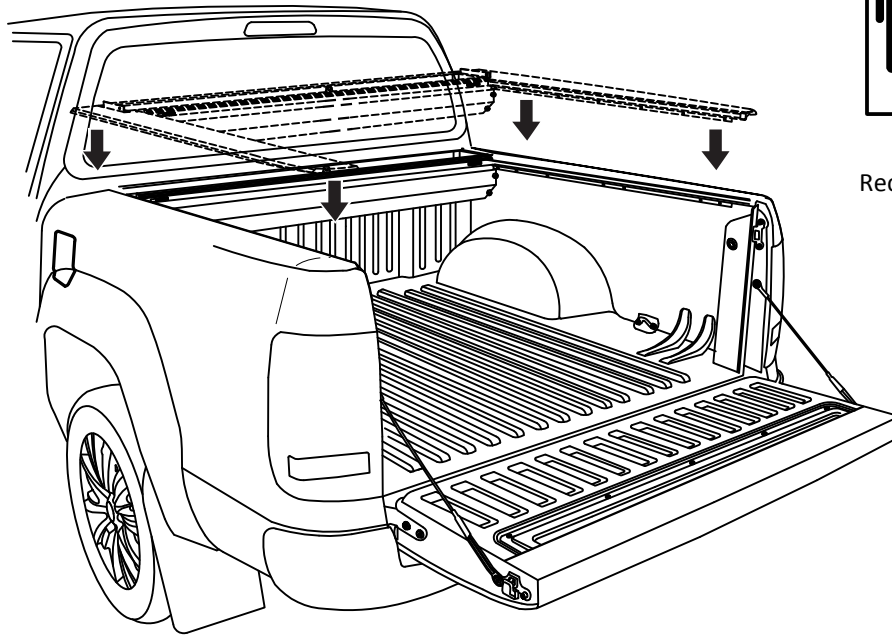

4 People
Recommended for lift

— Step 18 —

Before dropping the Roll R cover into place on the tub, connect all relevant connections or plugs to the receiver and motor plug connection.

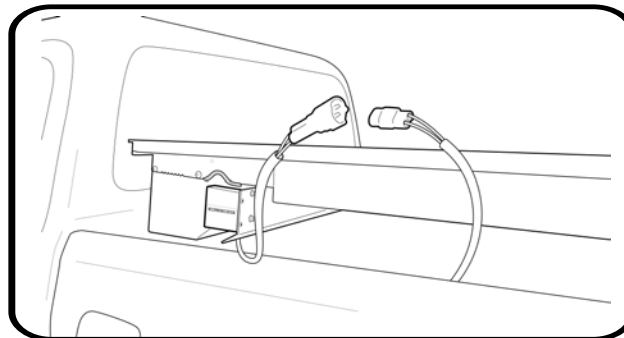
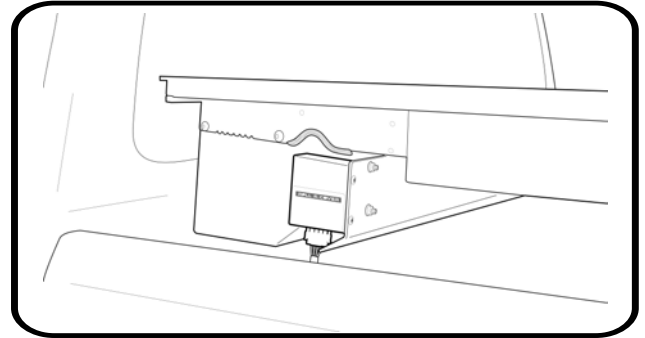
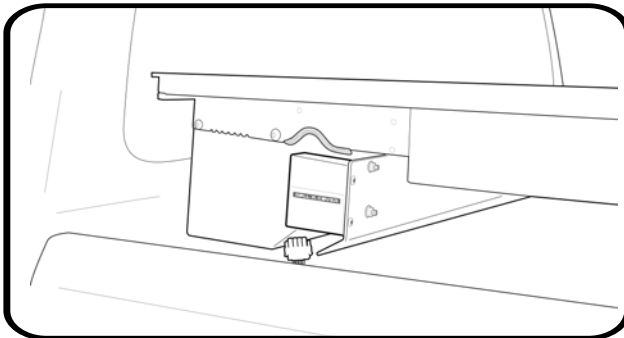

– Step 19

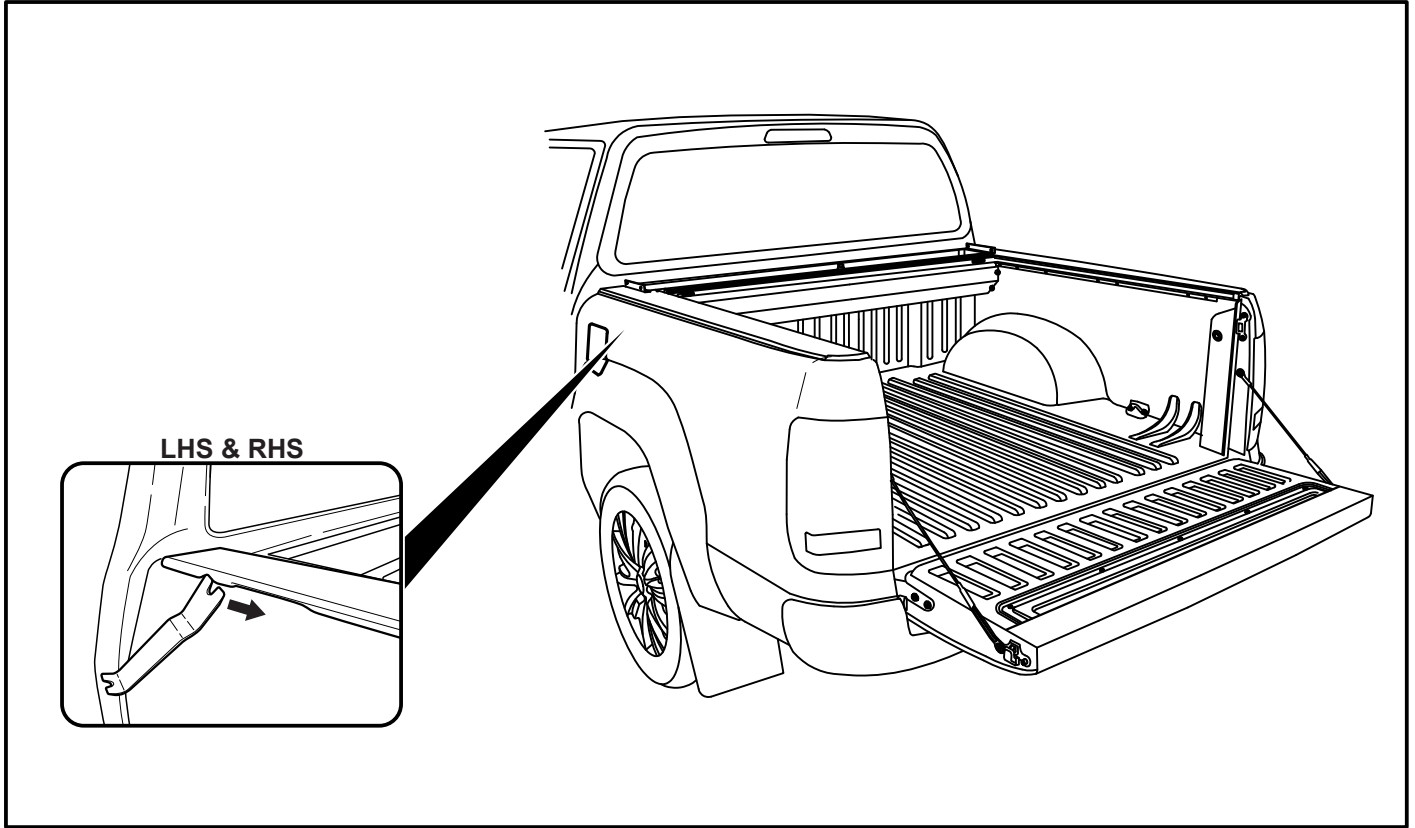

– Step 20

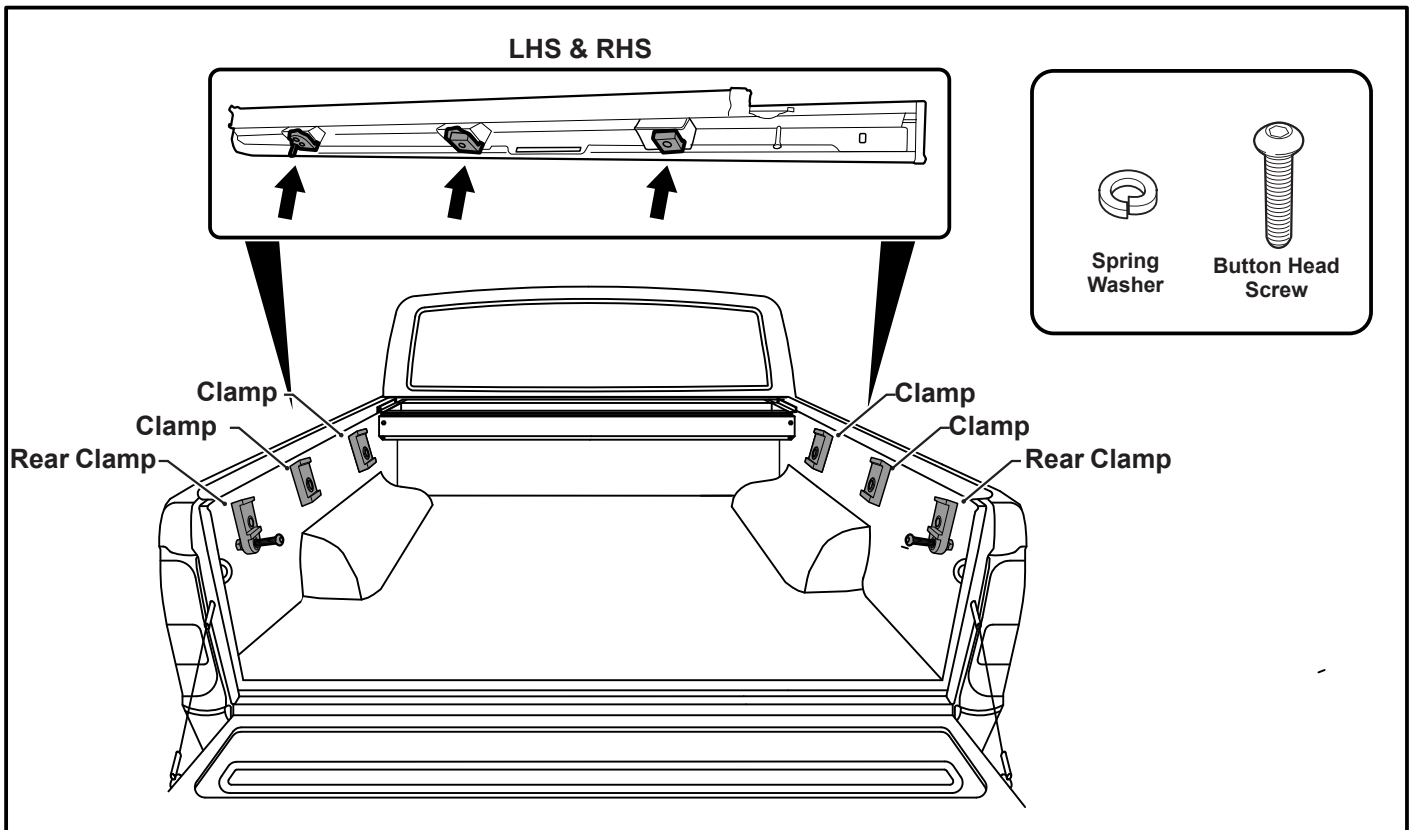

– Step 21

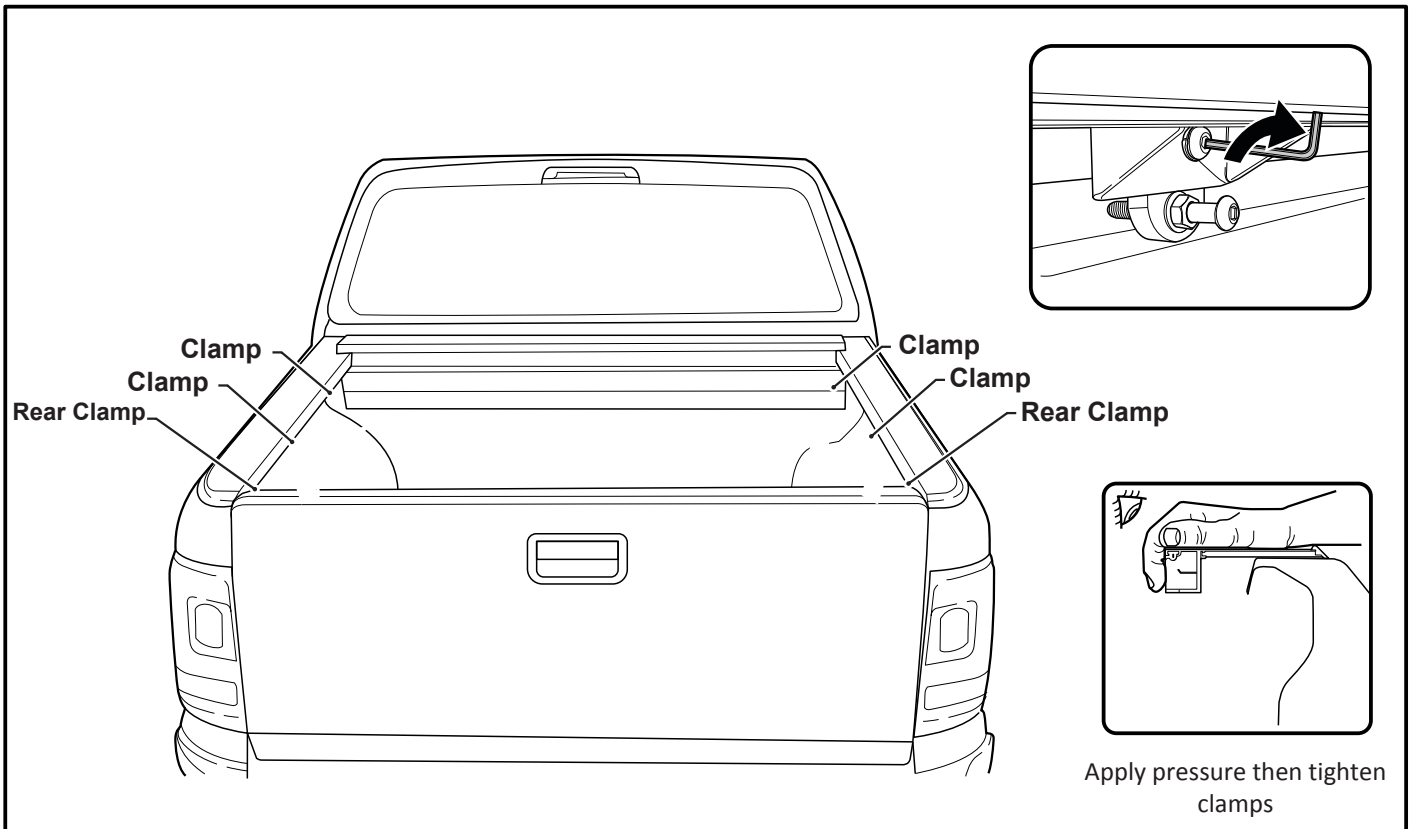

– Step 22

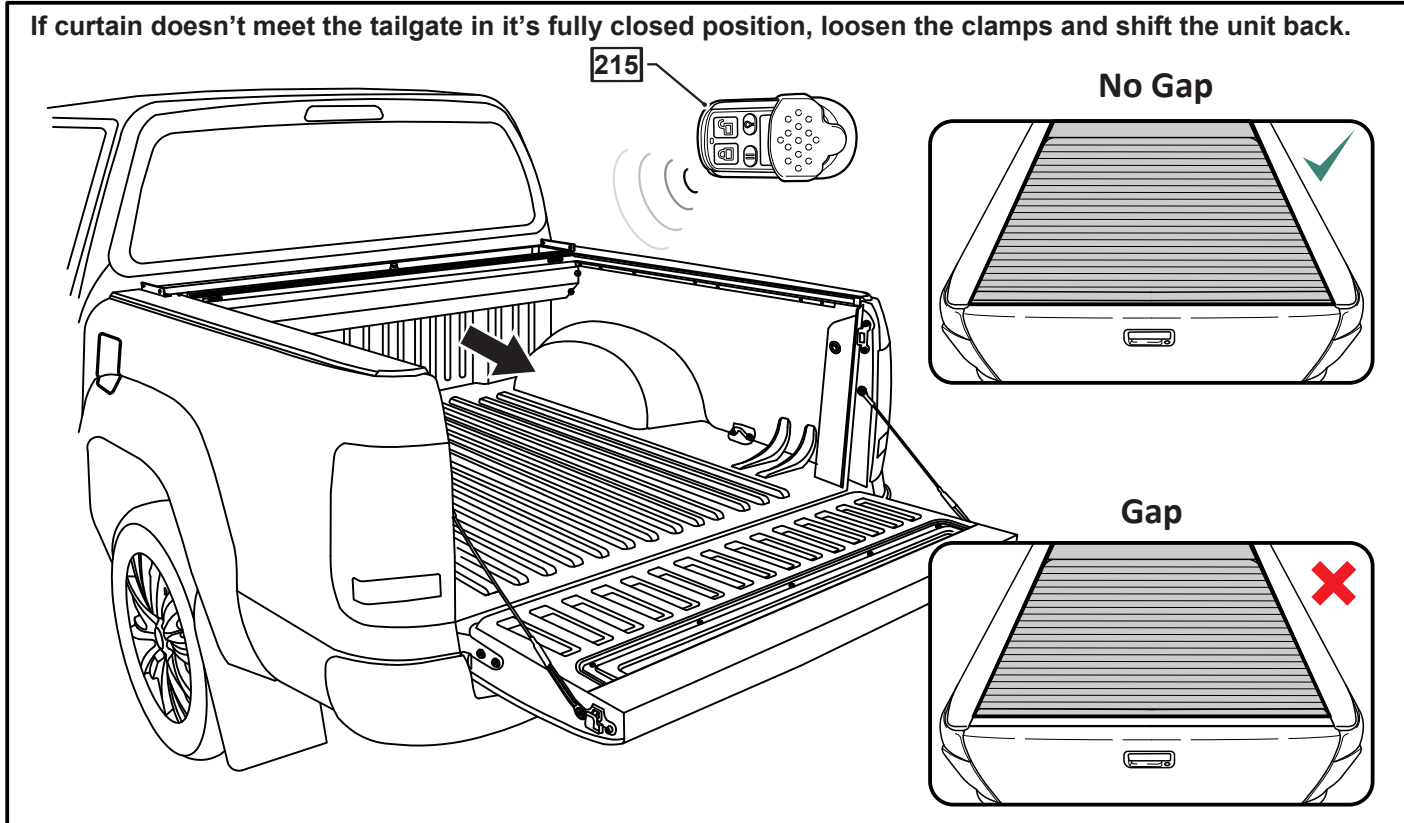

– Step 23

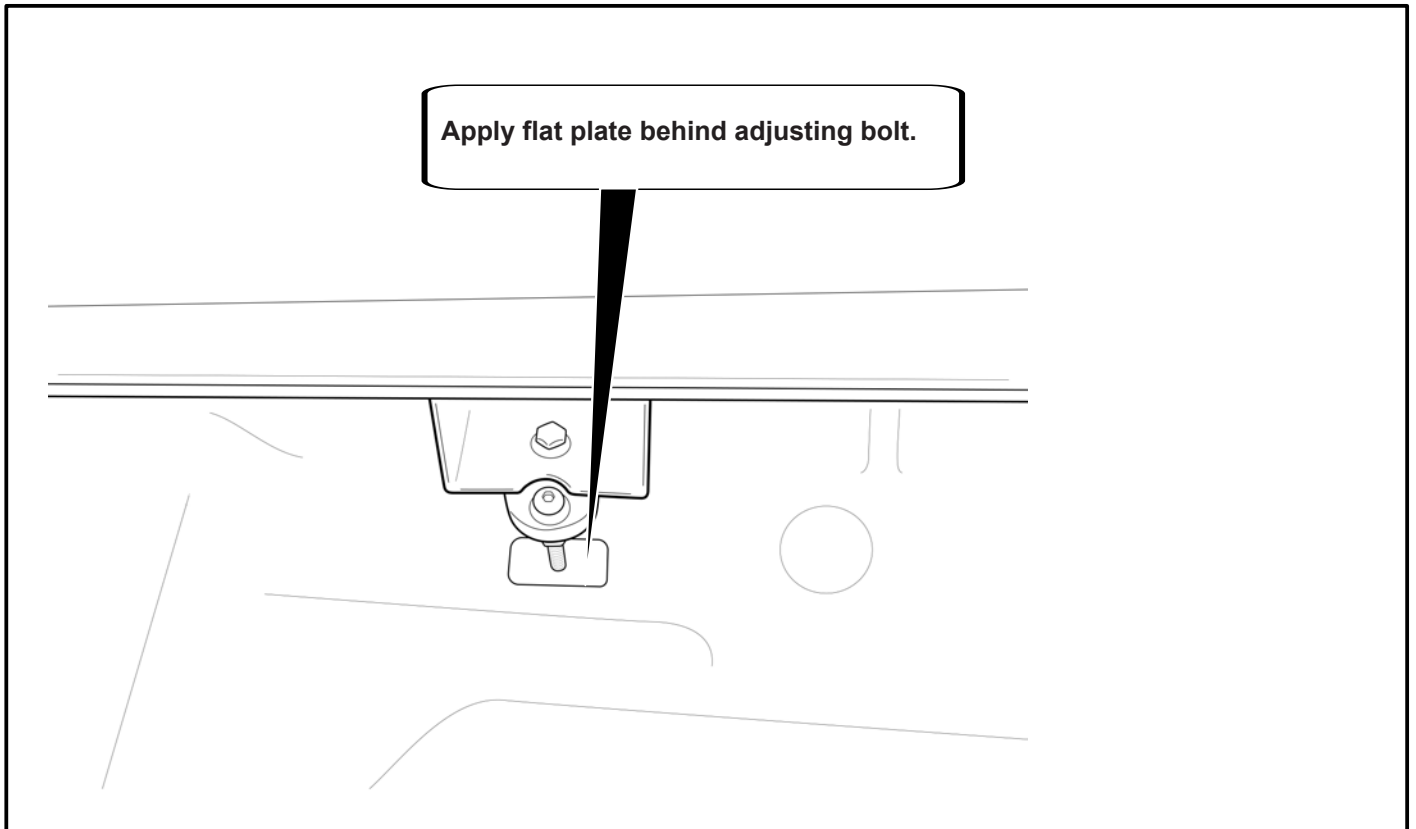

– Step 24

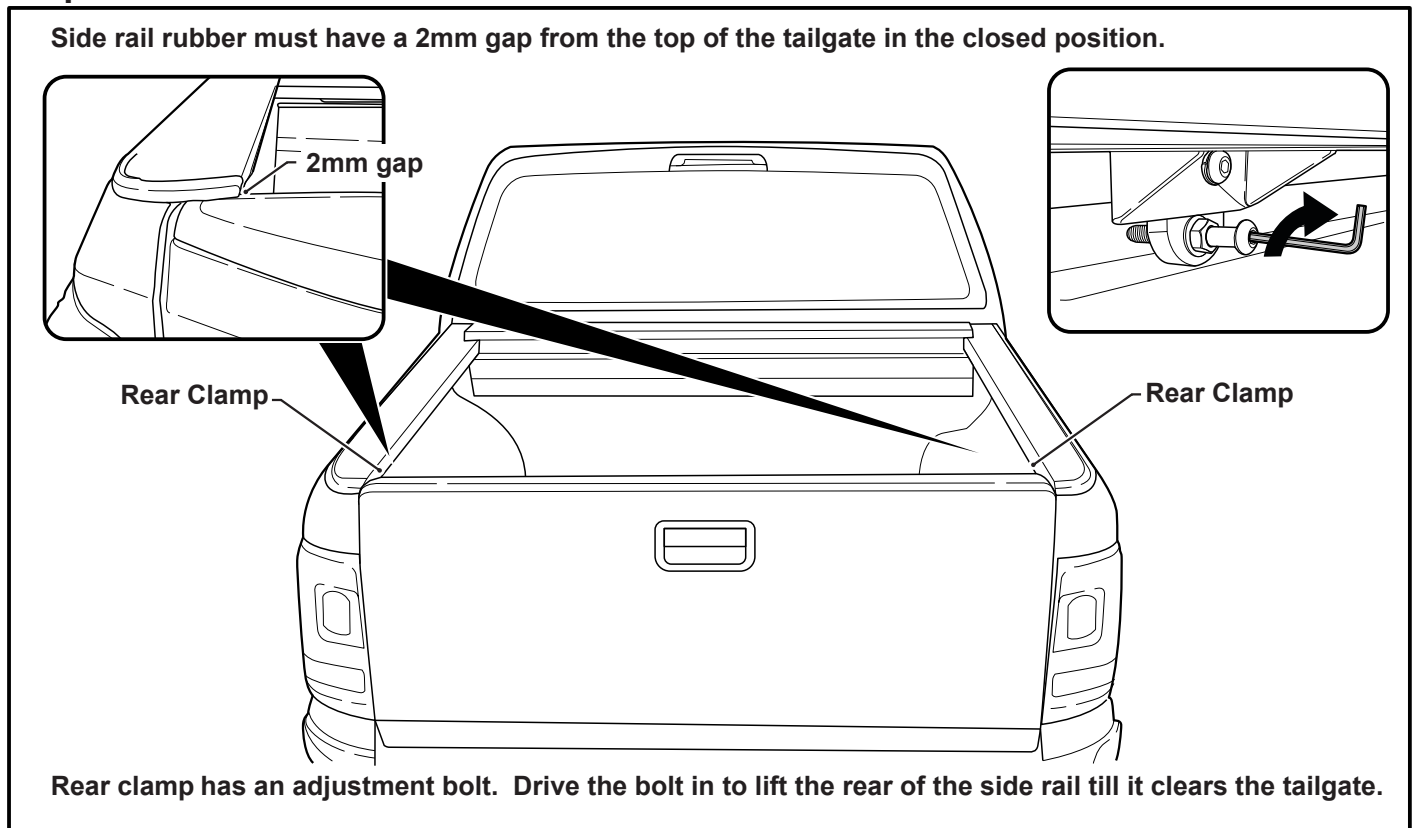

– Step 25

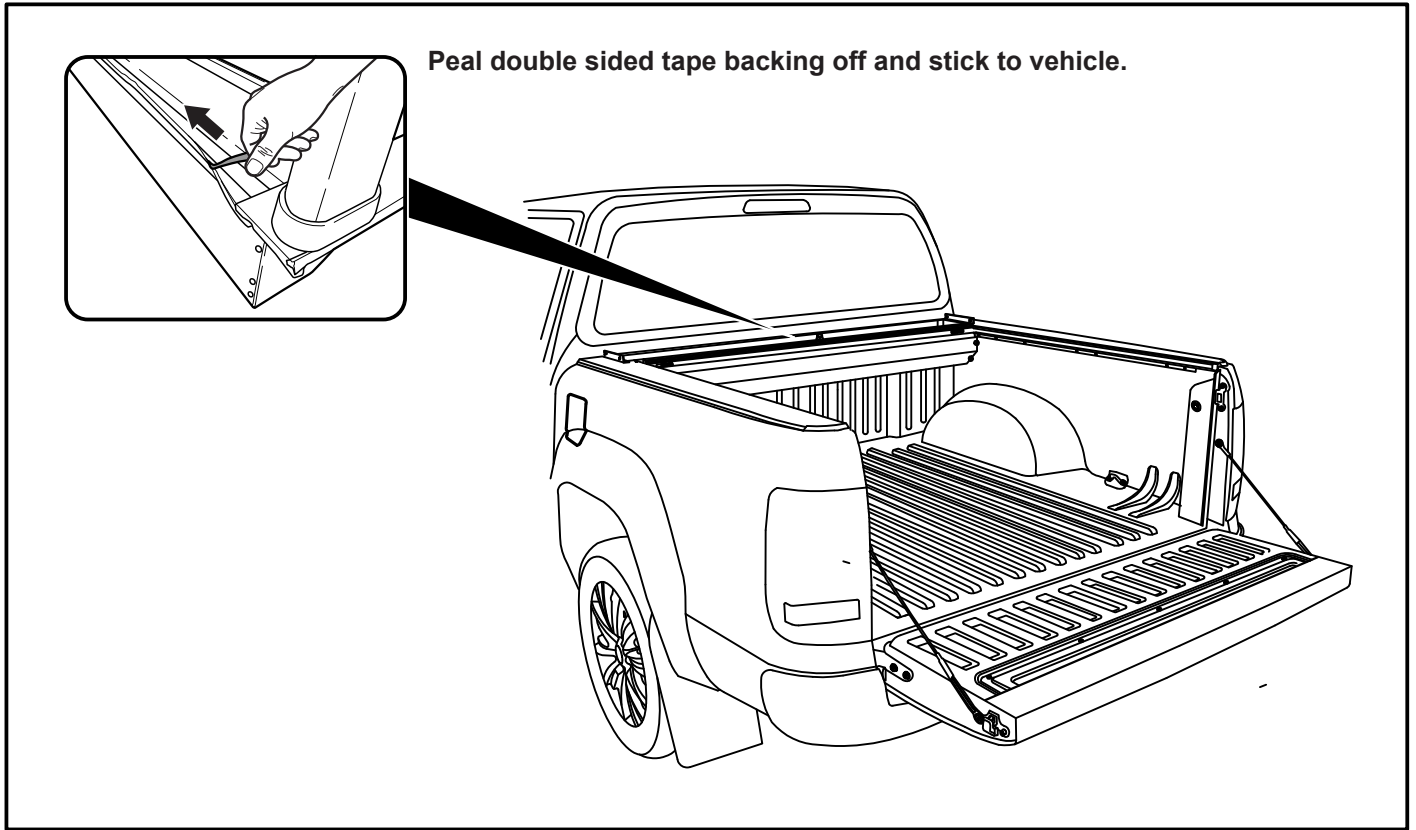

– Step 26

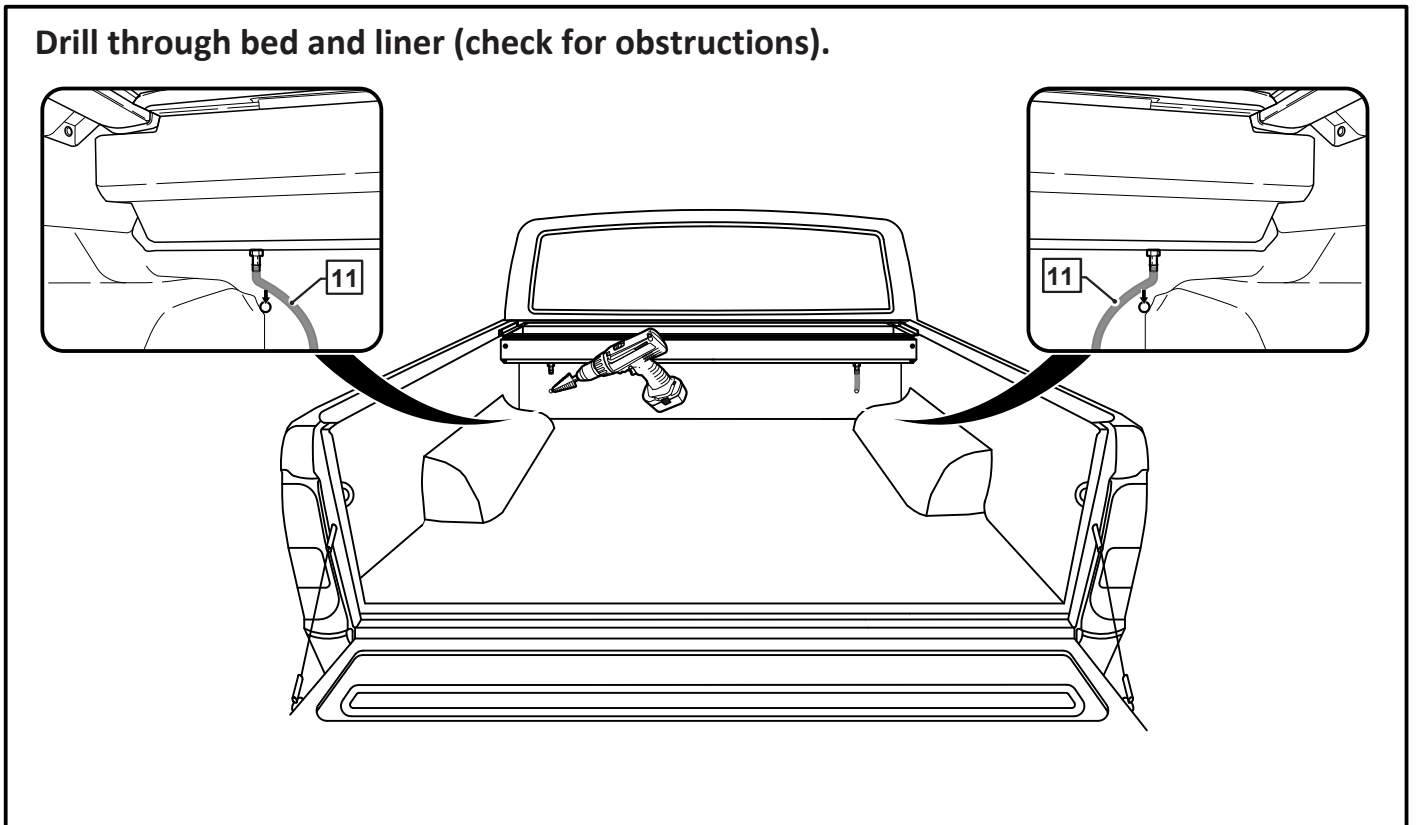

– Step 27

Remove the tail light to check for obstructions before drilling

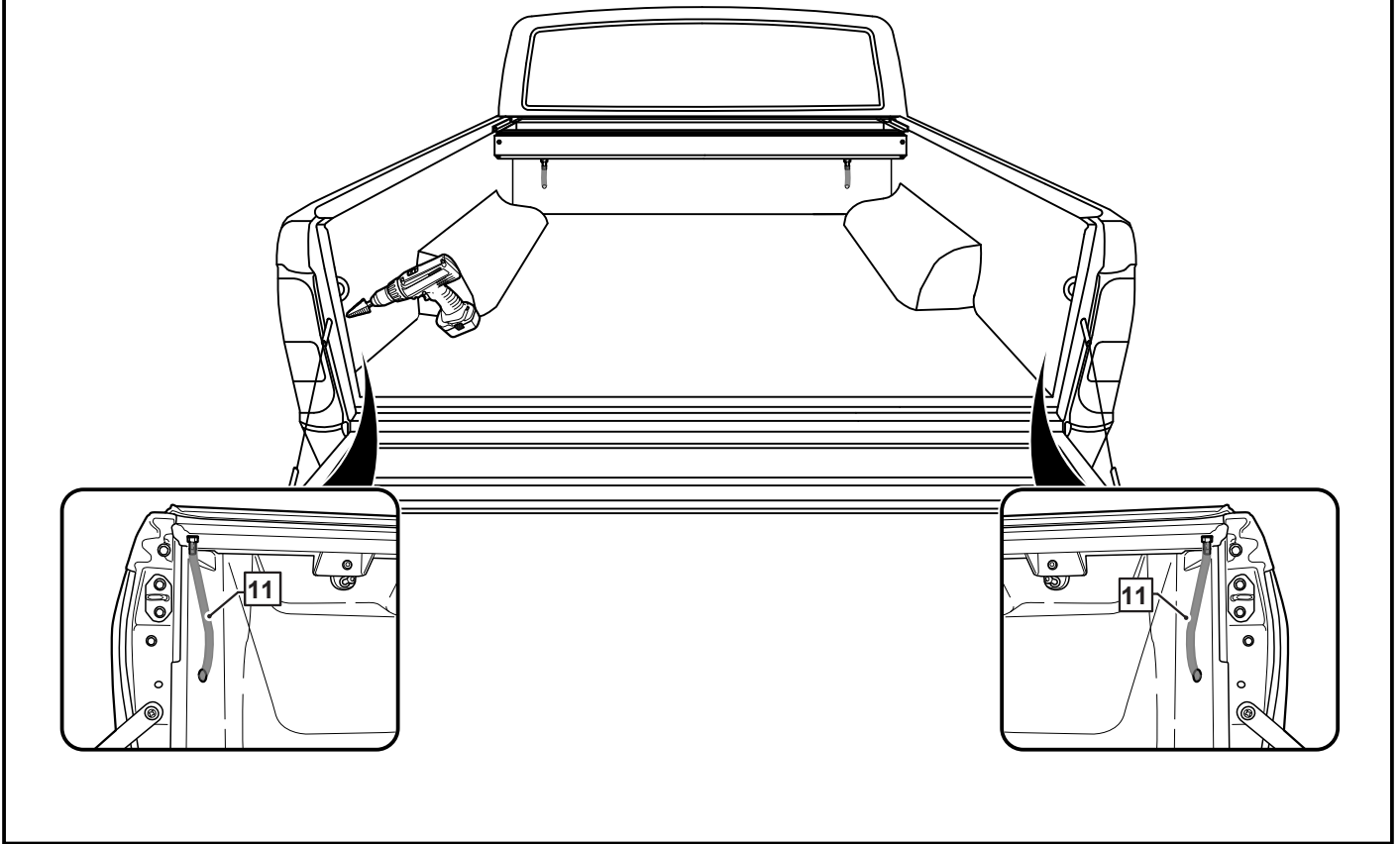

– Step 28

Snap fit the top cover.

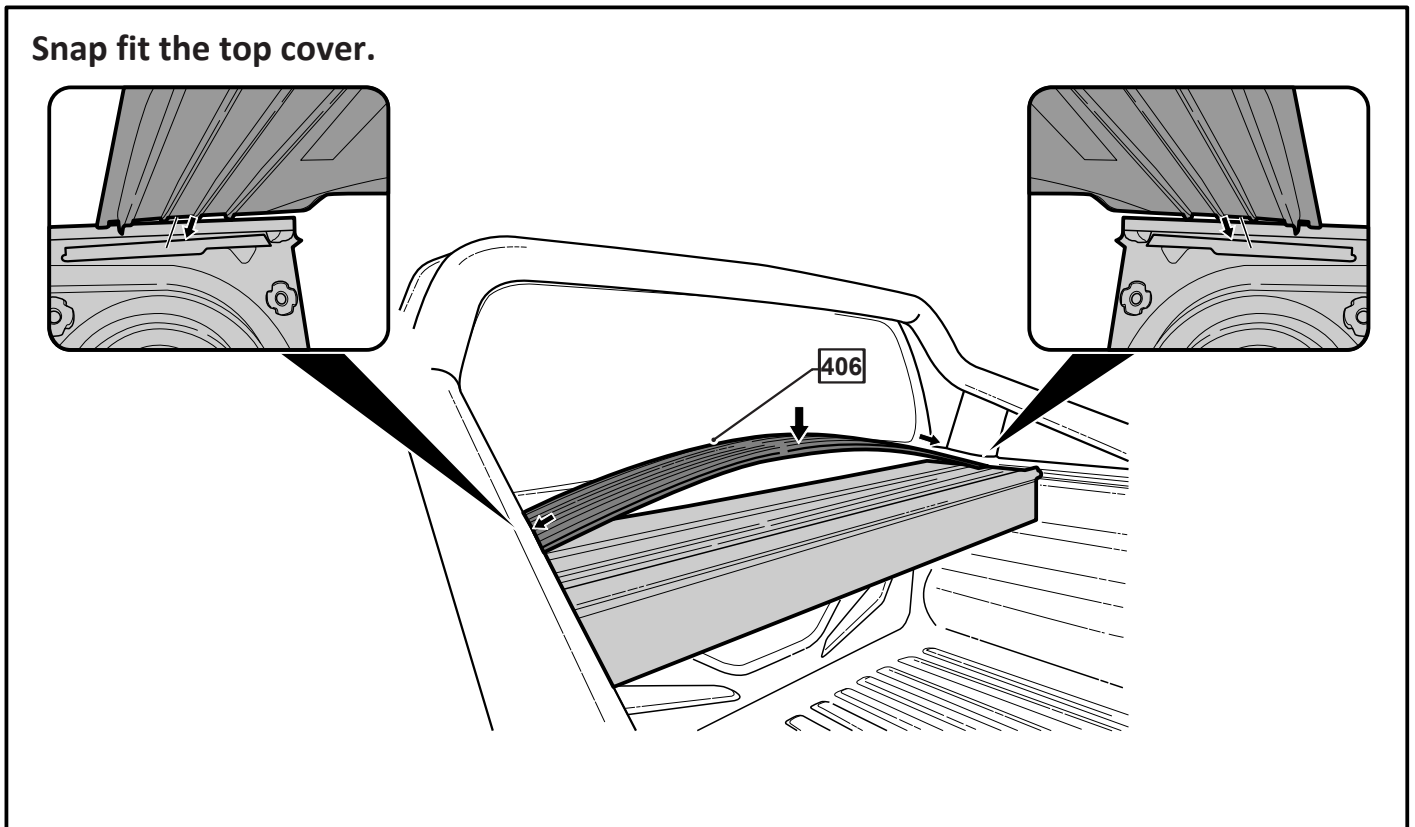

– Step 29

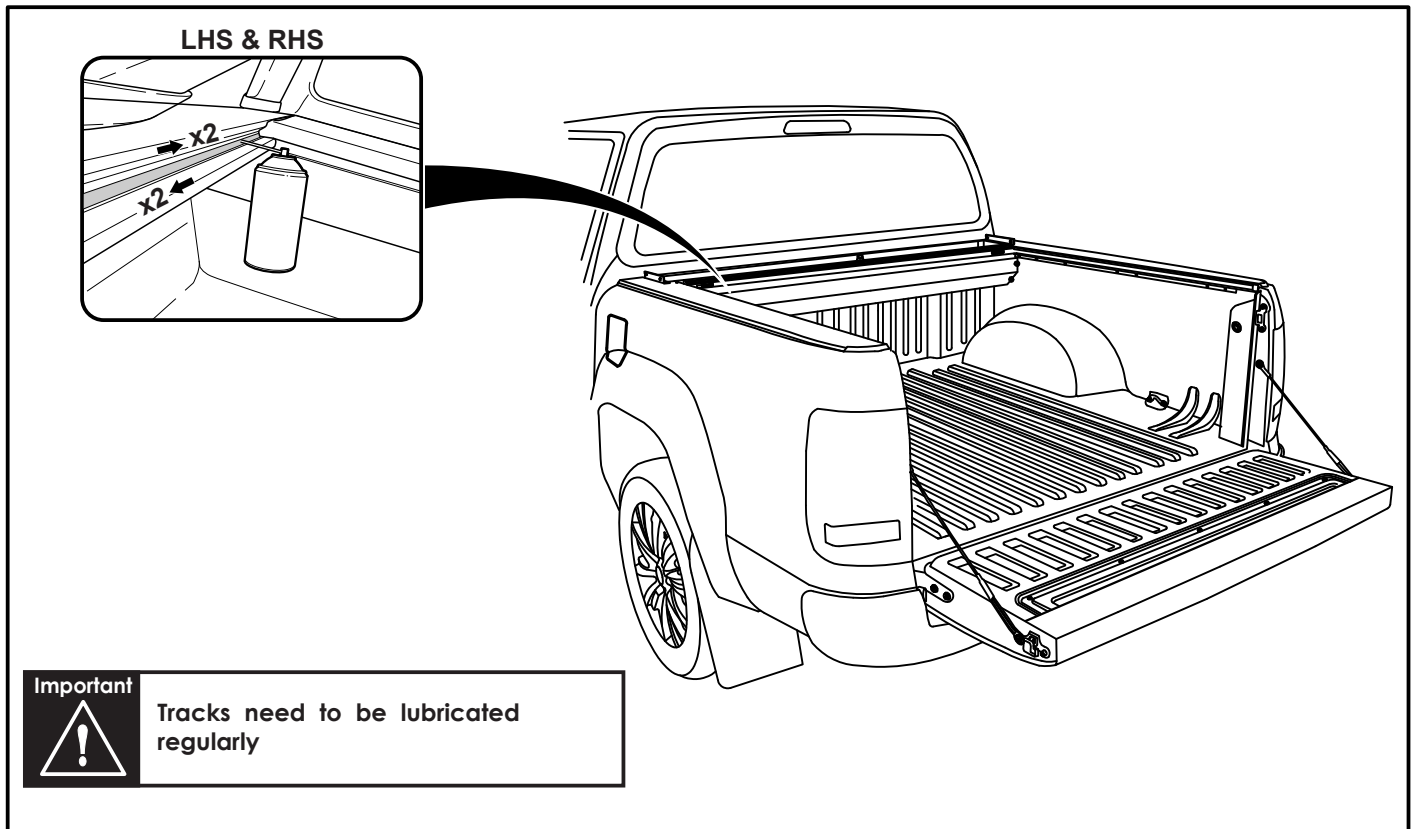

– Step 30

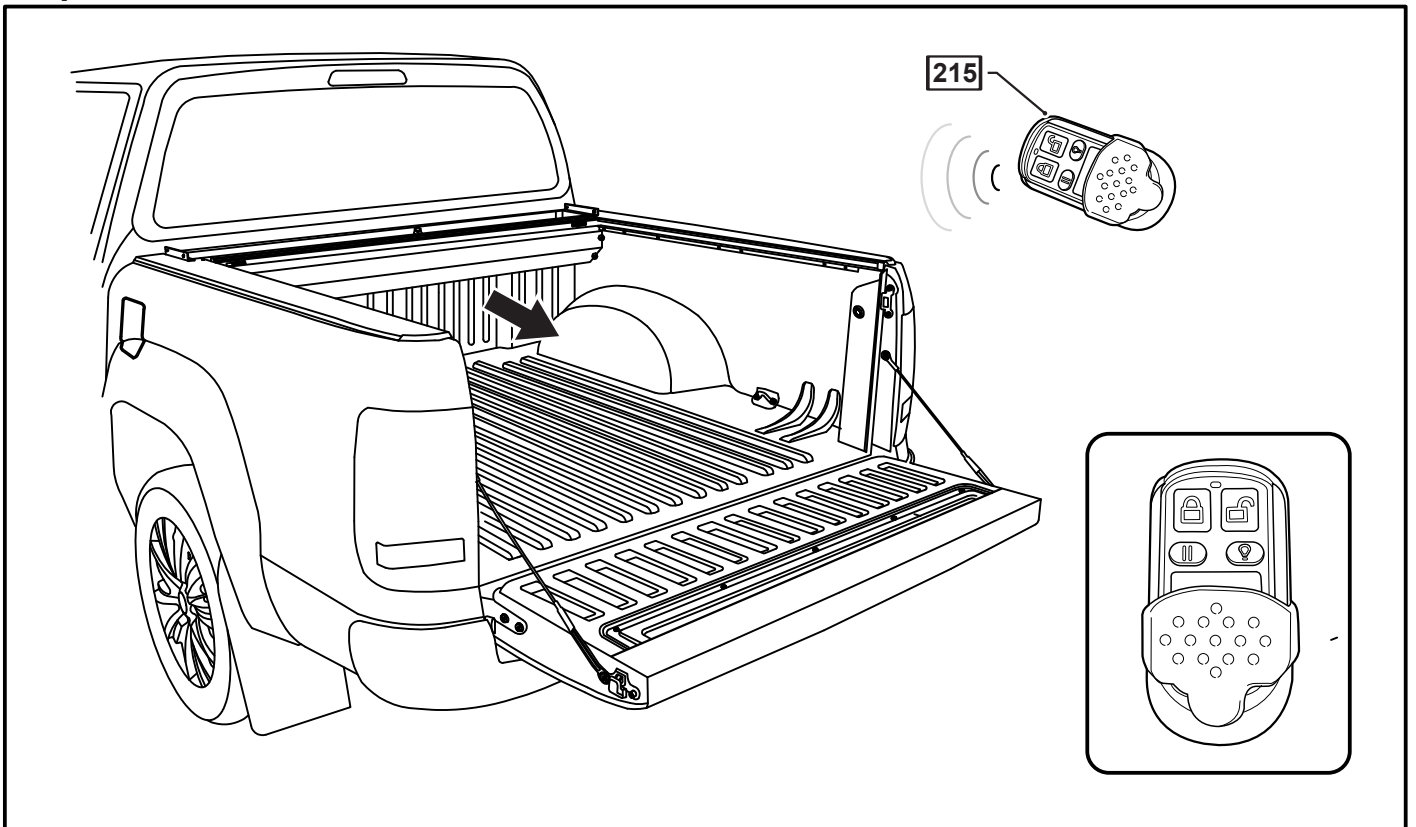

Important



You may open tailgate when Roll R Cover is in closed position, however you **MUST NOT** close the tailgate when Roll R Cover curtain is in the fully closed position.

WARNINGS! www.hsputelids.com

 NO STANDING	 ENSURE LOAD IS SECURE	 OIL CHECK GLIDES OIL REGULARLY	 6Nm CHECK CLAMPS AND TIGHTEN	 kg DO NOT PLACE LOAD ON COVER	 CHECK DRAIN CLEAN CANISTER	 MECHANICAL HAZARD	 NO PEOPLE OR ANIMALS UNDER ROLL TOP
-----------------	------------------------------------	--	--	---	--------------------------------------	--------------------------	---

E. & O.E. This document is copyright and must not be used except as permitted below or under the Copyright Act 1968. You may reproduce and publish this document in whole or in part for your or your organisation's own personal or internal compliance, educational or non-commercial purposes. You must not alter or amend this document in any way. You must not reproduce or publish this document for commercial gain without the prior written consent of the copyright owner.