



Important Information!

Please note that with the box of the Roll R Cover, there is a service kit that includes:

- A User Guide**
- Specific Lubrication**
- A Servicing Guide**
- A Warranty Guide**

This must be handed over to the end user in order for them to register their warranty and understand the servicing requirements.

ROLL. R. COVER[®]
SERIES 3



INSTALLATION INSTRUCTIONS

To suit Nissan Navara Face Lift Dual Cab
MY21+ with sports bars



INSTALLATION TIME: 2.5 Hours (Approximately)

This instructions has QR codes on relevant sections. You must scan the QR codes via your smart phone camera and watch the video to ensure your fitment is to standard.

IMPORTANT	<ul style="list-style-type: none"> • Do not stand/sit or rest heavy objects on Roll R Cover • Humans or animals are not to be under the closed cover at any given time • Tonneau Cover is not dust or water tight • If contact with volatile chemicals occur, clean Cover with mild detergent and water solution 			
Care Instructions	<ul style="list-style-type: none"> • Read Instructions fully before commencing installation. • Clean Cover with a mild detergent and water solution • Do not use abrasive cleaners or solvents • Refer to manufactures instructions applicable to power drill. • Protect Tub floor against scratches during installation process. 			
Maintenance	Refer to Maintenance instructions.			
Tools Required	<table border="0"> <tr> <td> <ul style="list-style-type: none"> • Pen / Marker • Centre Punch • Drill & Drill bits • Caulking Gun • Silicon - Non Acetic </td> <td> <ul style="list-style-type: none"> • Scissors & Knife • Spanner & Socket • Tape measure • Holesaw • Filing tool </td> <td> <ul style="list-style-type: none"> • Soapy water solution • Allen Key set • Screw driver • Rust Inhibitor • Trim Removal Tool </td> </tr> </table>	<ul style="list-style-type: none"> • Pen / Marker • Centre Punch • Drill & Drill bits • Caulking Gun • Silicon - Non Acetic 	<ul style="list-style-type: none"> • Scissors & Knife • Spanner & Socket • Tape measure • Holesaw • Filing tool 	<ul style="list-style-type: none"> • Soapy water solution • Allen Key set • Screw driver • Rust Inhibitor • Trim Removal Tool
<ul style="list-style-type: none"> • Pen / Marker • Centre Punch • Drill & Drill bits • Caulking Gun • Silicon - Non Acetic 	<ul style="list-style-type: none"> • Scissors & Knife • Spanner & Socket • Tape measure • Holesaw • Filing tool 	<ul style="list-style-type: none"> • Soapy water solution • Allen Key set • Screw driver • Rust Inhibitor • Trim Removal Tool 		

PERSONAL PROTECTIVE EQUIPMENT:



Rubber Gloves



Goggles



Hearing Protection

BOX CONTENTS

LEFT & RIGHT SIDE RAIL

S2.5-DC-AE-002ps-NN42 

S2.5-DC-AE-003ds-NN42 



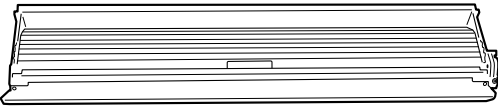







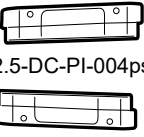

CANISTER ASSEMBLY

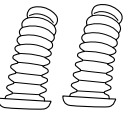
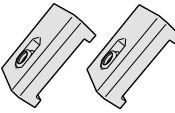
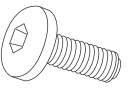
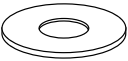

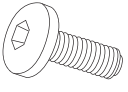

S3-DC-AF-NN4R-001-002

CANISTER TOP COVER  **S2.5-DC-AE-005 -NN4**





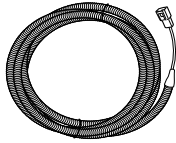
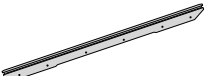

STANDARD KIT

<p>COVER END CAPS</p>  <p>S2.5-DC-PI-004ps S2.5-DC-PI-004ds</p>	 <p>COUNTERSUNK SCREW Qty - 4</p>	 <p>CABLE TIE Qty x 16</p>	 <p>BATTERY LOOM S2.75</p>	 <p>Drainage pipe Qty - 2</p>	 <p>SIDERRAIL CLAMP Qty - 4</p>
 <p>M8 x 35mm Qty - 8</p>	 <p>M8 WASHER Qty - 16</p>	 <p>M8 SPRING WASHER Qty - 4</p>	 <p>M8 NUT Qty - 4</p>	 <p>M8 NYLOC NUT Qty - 4</p>	
 <p>M6 x 20mm Qty - 4</p>	 <p>M6 SPRING WASHER Qty - 4</p>	 <p>P-9595 PS bracket Qty 1</p>	 <p>P-9596 DS bracket Qty 1</p>		

SPECIFIC KIT NMA4R

 <p>NN-PATCH-K</p>	 <p>CL-LOOM-SHORT</p>	 <p>ASSEMBLY BAR</p>	 <p>M8 x 20 ALLEN Head Bolt Qty - 6</p>	 <p>Clear protective tape (30mm x 65mm) Qty - 2</p>	
--	---	--	---	--	--

SPORTS BAR KIT NN42R

 <p>3M PRIMER</p>	 <p>L/H SIDERRAIL HOLE GASKET Qty - 2</p>	 <p>R/H SIDERRAIL HOLE GASKET Qty - 2</p>	 <p>M10 FLAT WASHER Qty - 4</p>	 <p>M10 LOCK NUT Qty - 4</p>	
 <p>FRONT SPACER(704) Qty - 2</p>	 <p>REAR SPACER (705) Qty - 2</p>				

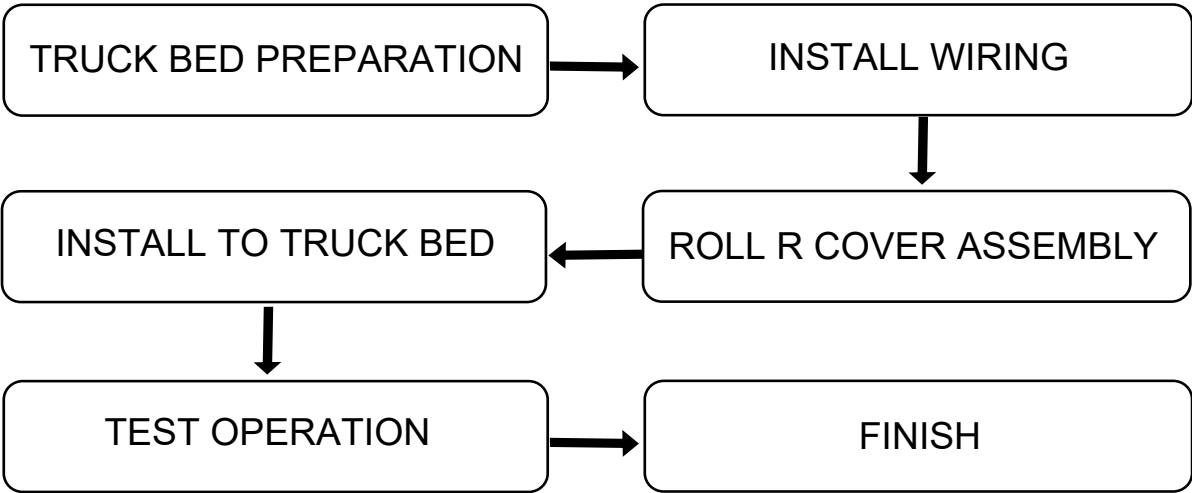

TUB PREPARATION

If the Vehicle is fitted with a sports styling bar, remove from Ute Tub (truck bed) including any bracket's holding it.



VISUAL TIP

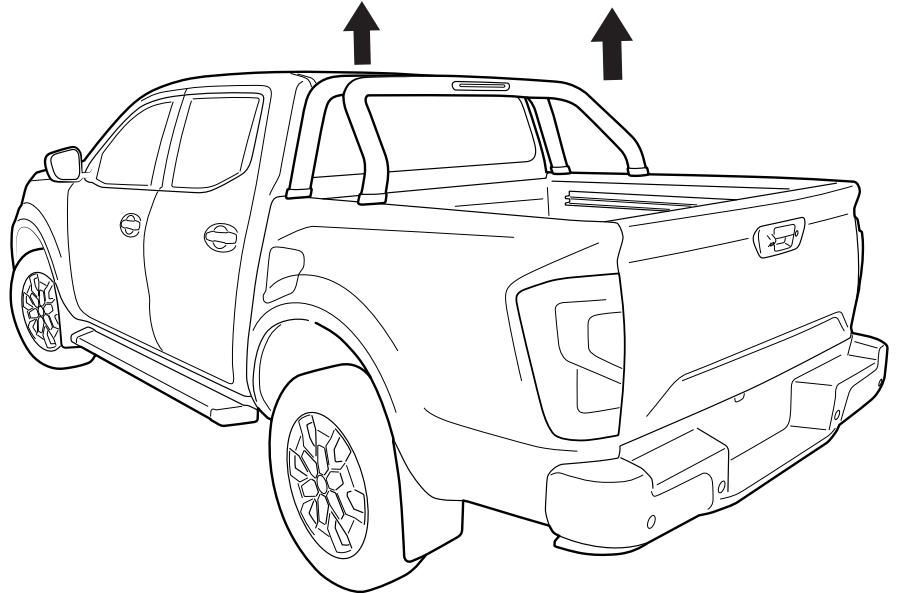
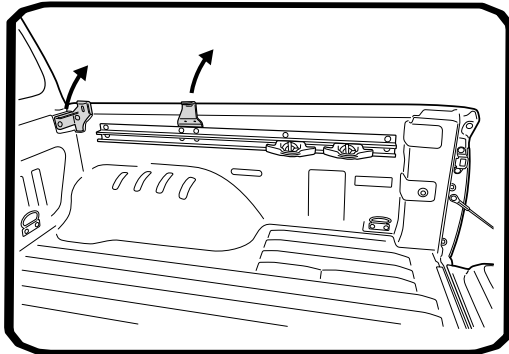

Clean are as indicated.

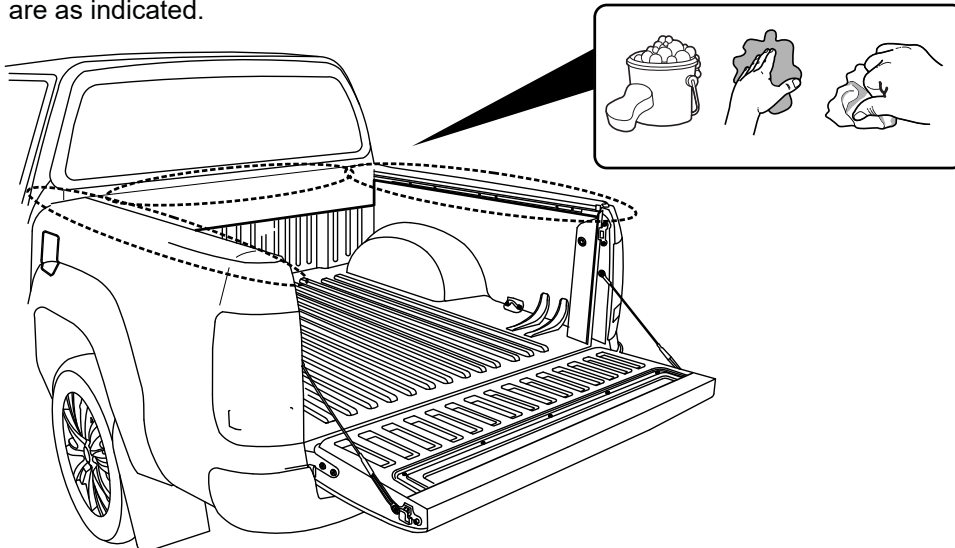

Carefully unpack the box.

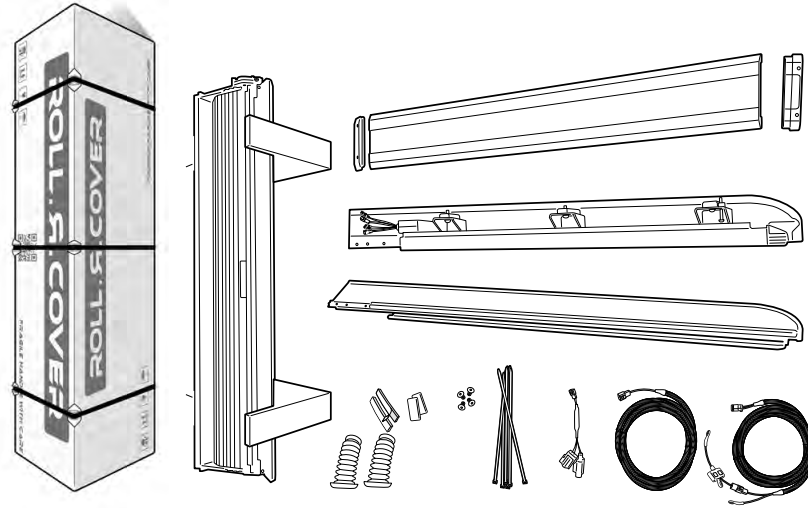

1. Unfasten and retain 4 factory bolts as indicated.
2. Remove factory grommet (left and right grommet and discard).

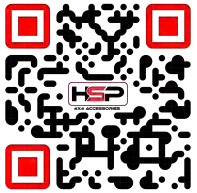

 VISUAL TIP

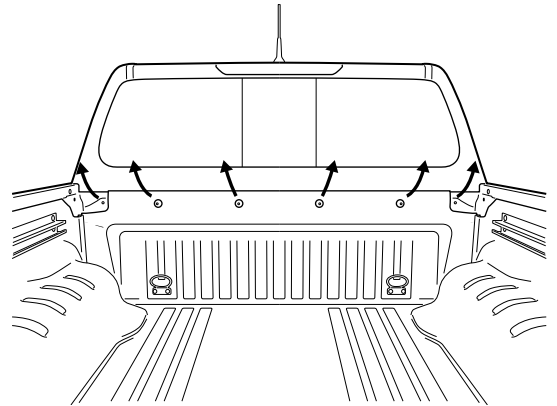

Place Front bar assembly to headboard and line up with factory threads. Note: If tub is fitted with factory liner, place Front bar assembly between head board and liner.
Push down on the bar while fasten using factory bolts where possible. M8 bolts are provided in the kit where needed.
Fasten to 10 NM torque.

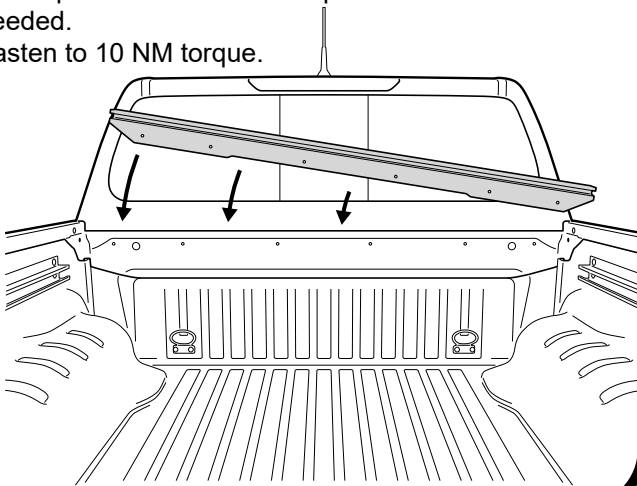

Fasten into position with supplied allen head M8 x 20mm bolts.
Fasten to 10 NM torque.

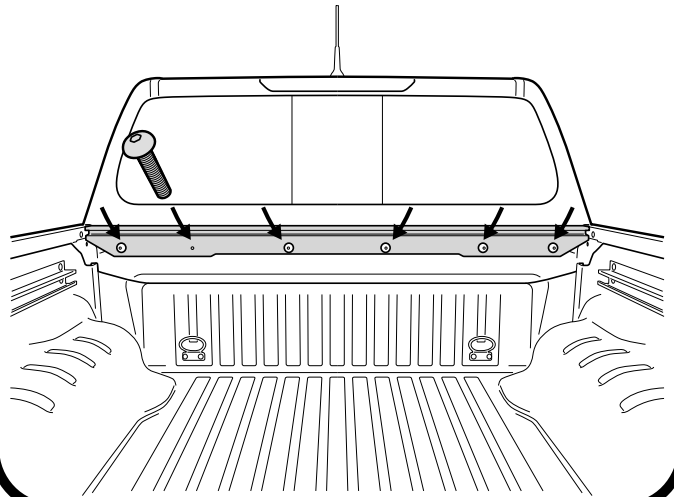

 VISUAL TIP

Measure down from top of headboard 225mm & 65mm from inside wall of bed liner as shown. Repeat to the other side.
Using a 50mm hole-saw drill the liner only as indicated.

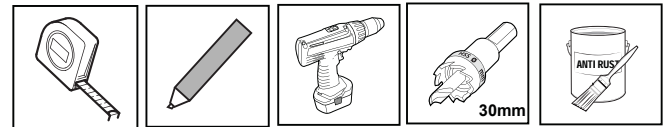
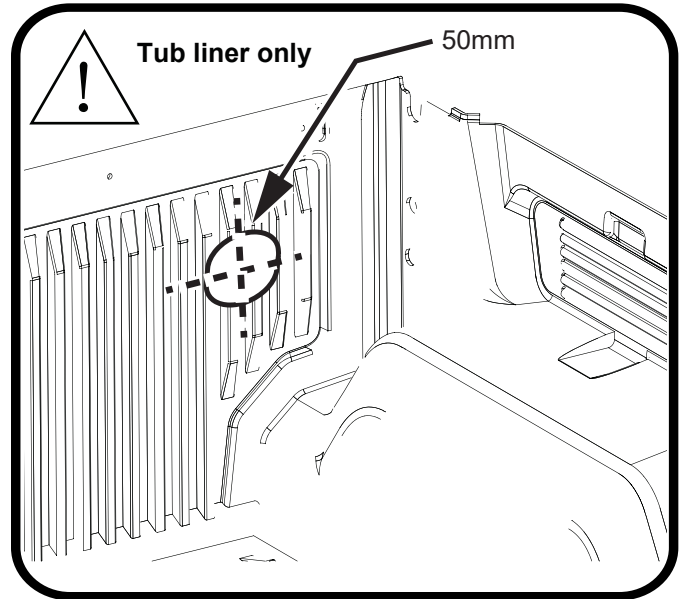
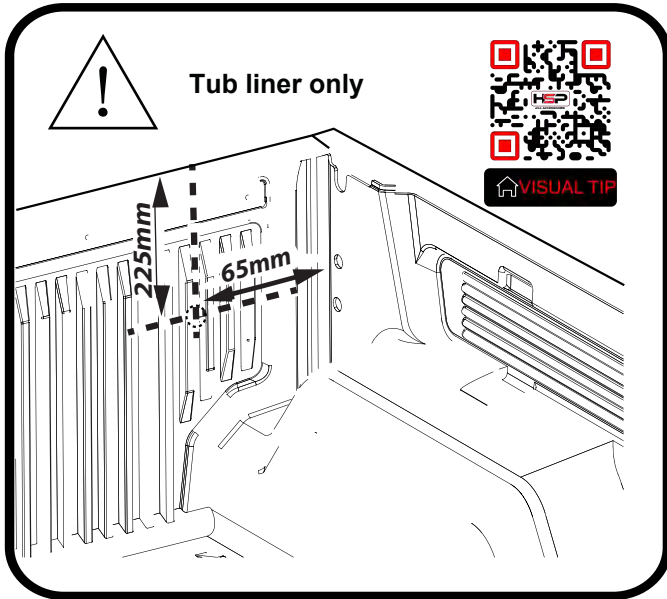
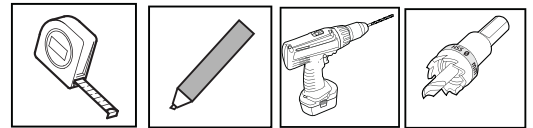

Measure down from top of headboard 225mm & 70mm from inside wall of bed as shown.
Repeat to the other side.
Using a 30mm hole-saw drill through tub front panel, file away any sharp edges. Apply anti rust coating. Repeat to other side.

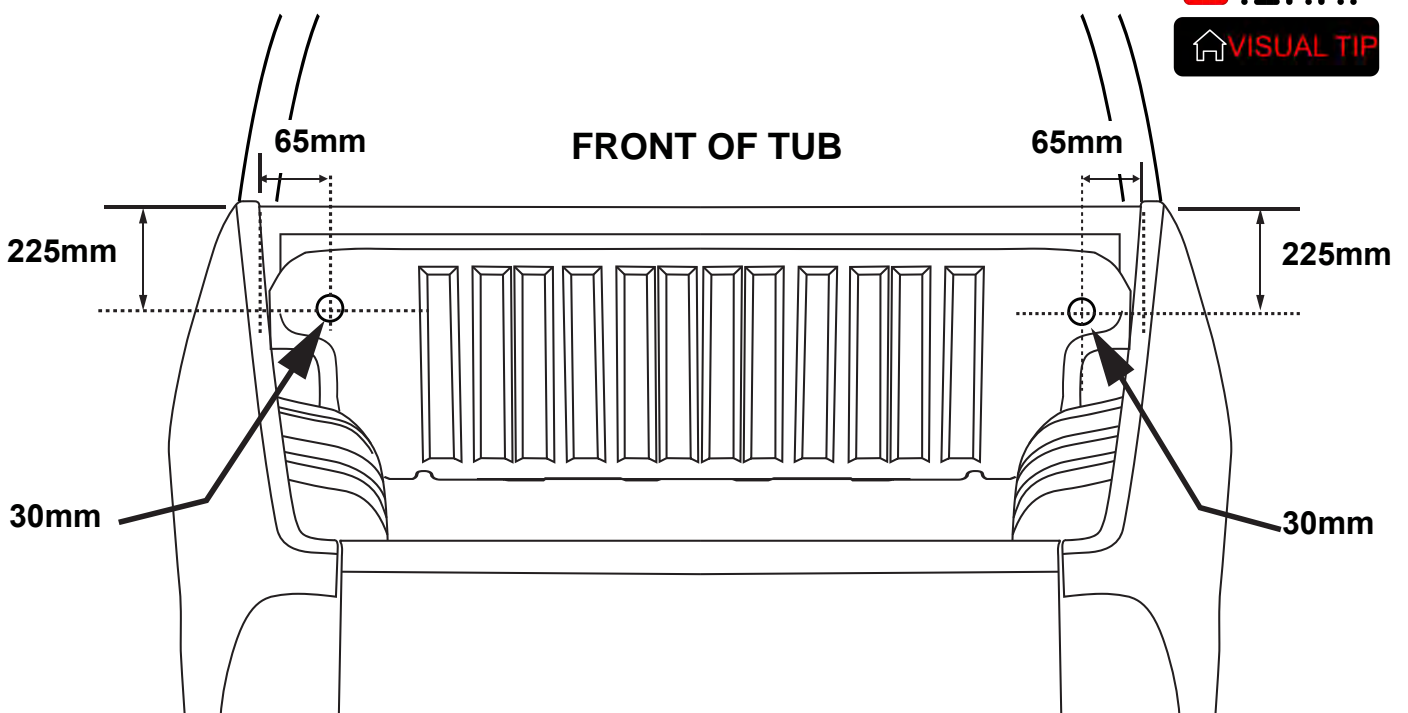
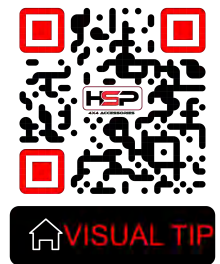

ATTENTION: Do not exceed 30mm hole.

Sealing any gaps on the bed and FBA. It is recommended to use black sealant.

Apply an adequate amount of sealant to the areas indicated, then smooth sealant out.

Clean any excess sealant. Repeat to the other side.

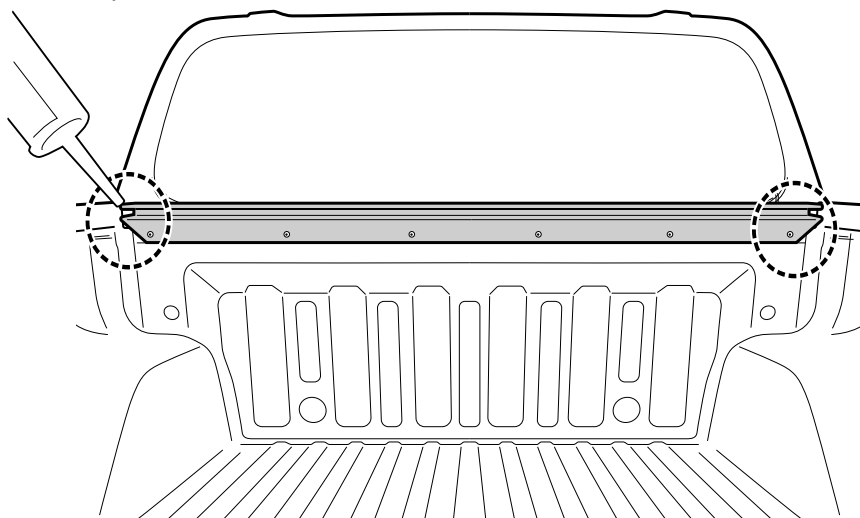

Apply an adequate amount of sealant to the area indicated, Repeat to the other side.

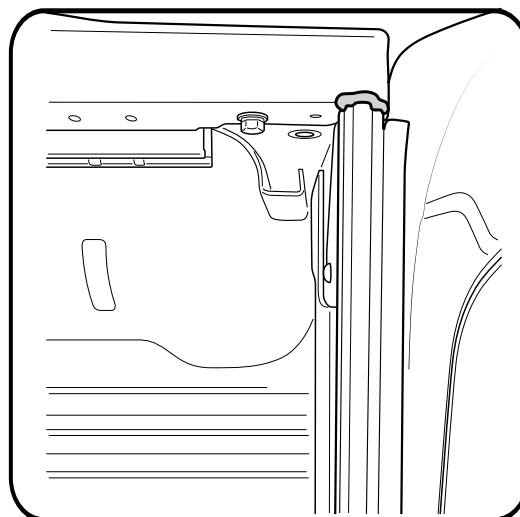
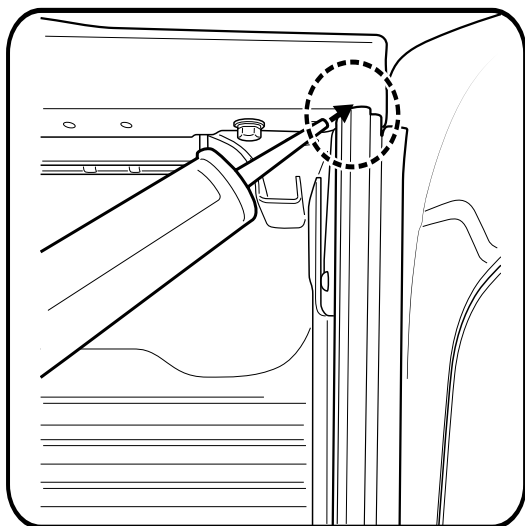

Install front drain pipes (55mm diameter end of hose) through pre-drilled holes on the front tub panel.



Note: With care push tube in.
Taking care pull the tube back so it seals correctly against the front panel of the tub.

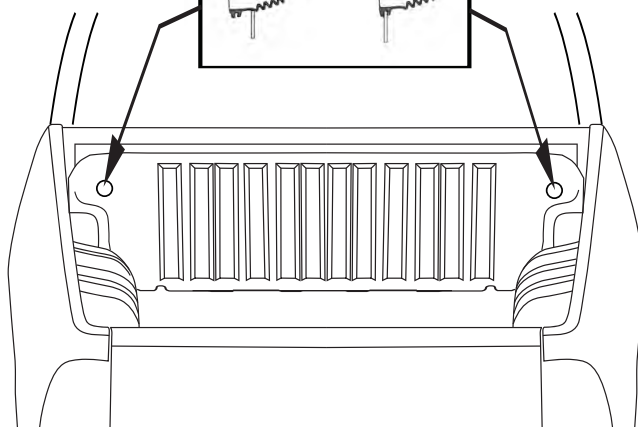
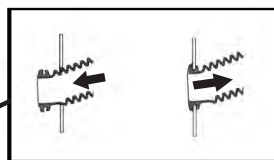

VISUAL TIP



Vehicles fitted with tub liner.

Align P-9596 drive side bracket to the area indicated.

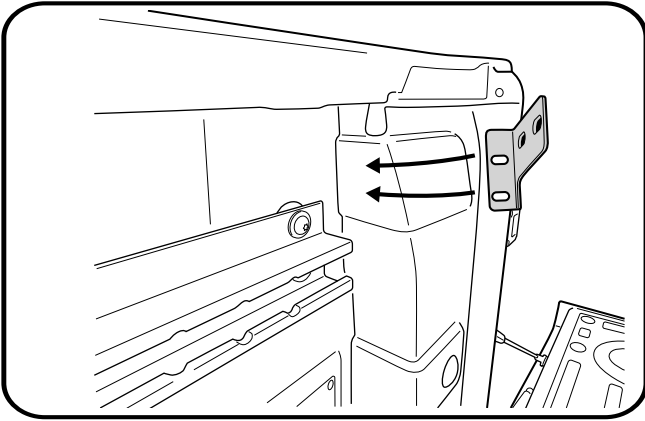

Push bracket up against the tub inner rail lip. Mark liner around the bracket as indicated.

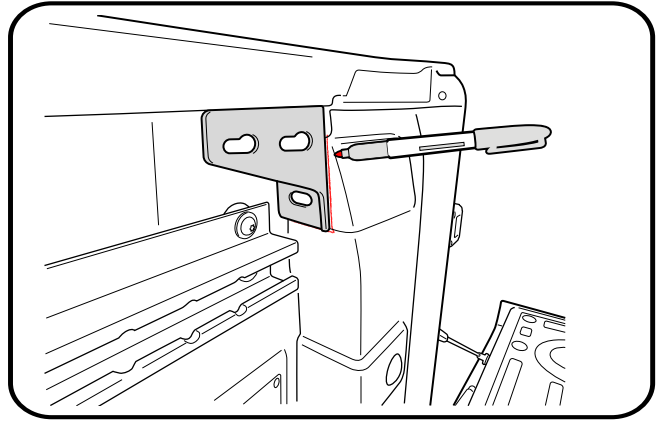

Trim liner around the marked location and discard piece.

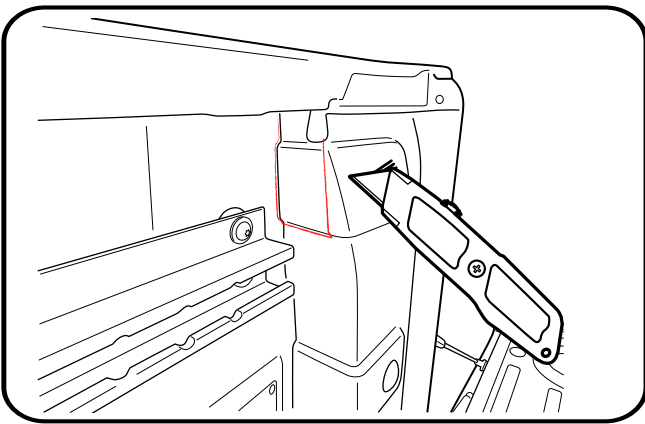

View with liner trimmed.

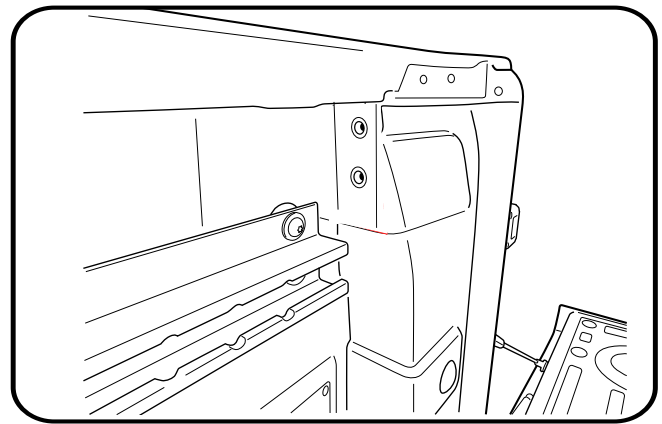

Unfasten the indicated bolts and discard. Repeat to the other side.

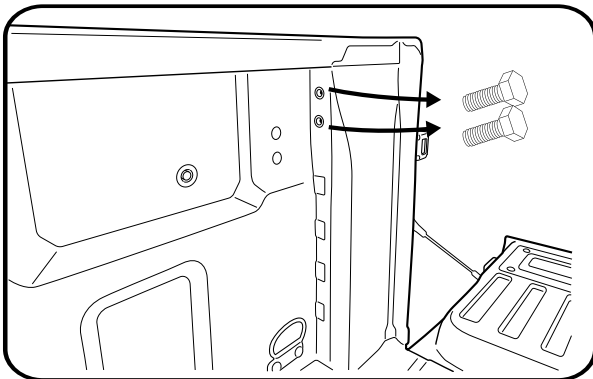

Place P-9596 driver side bracket over factory threads as indicated.

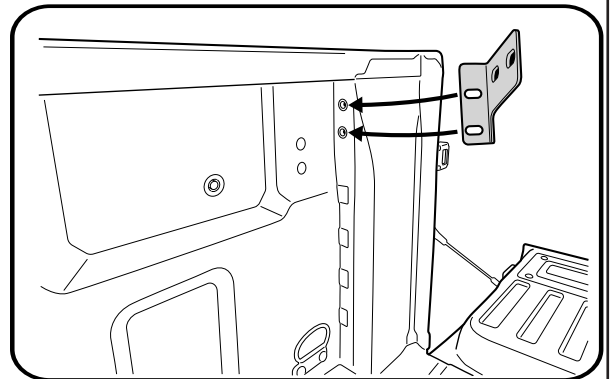

Push bracket up against the tub inner rail lip

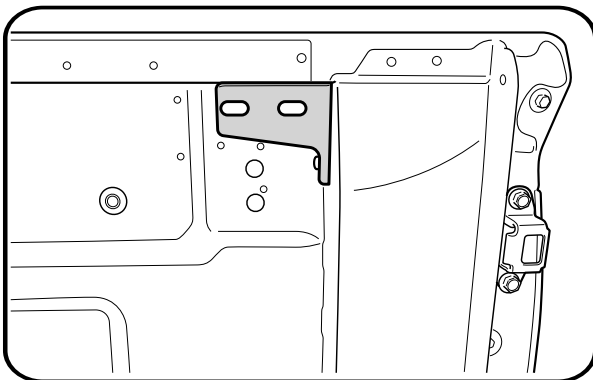

 **VISUAL TIP**

Fasten into position using M6x20mm button head bolt followed by M6 spring washer and M8 washer to 2Nm torque.

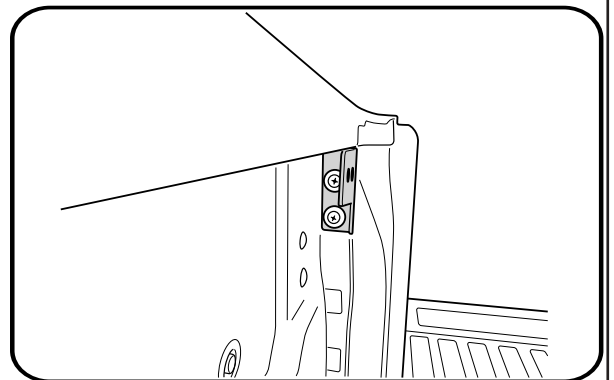

Disconnect fuse patch from battery loom S2.75.

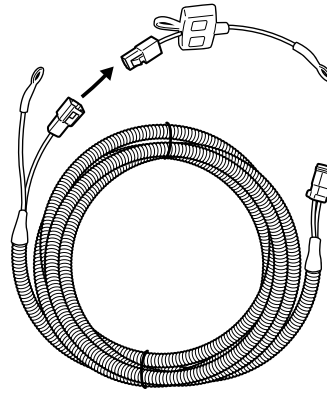

Wiring Harness steps

1 Feed Battery Loom S2.75 through the cavity*

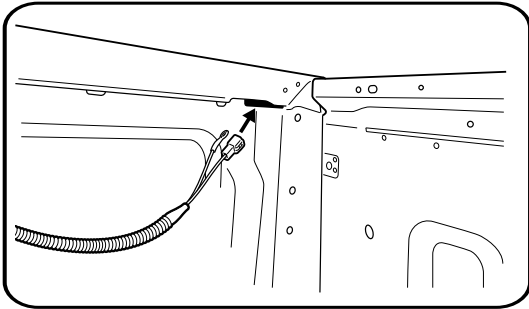

3

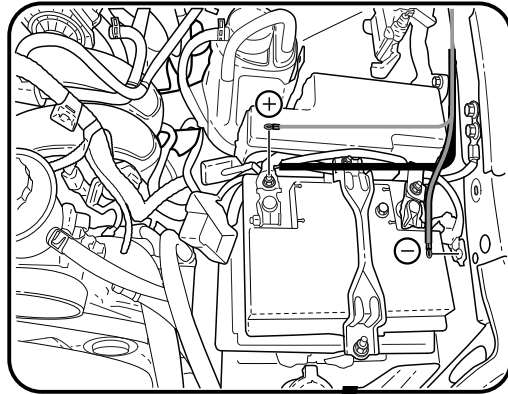

2

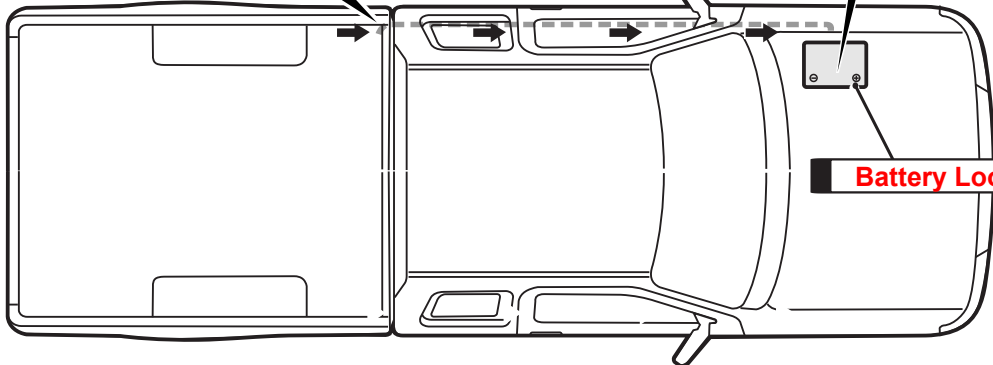

Run the wiring from the front corner cavity* (leaving 200mm in the tub) to the battery over the chassis rail. Making sure to keep away from hot obstructions and cable tie every 400mm. Reconnect fuse patch to battery loom S2.75, now attach fuse patch to positive of battery and earth to the body of the Ute.

* If limited room via cavity, locate any factory hole in the tub to exit. you may be required to enlarge or drill new hole.

Feed CL-Short-Loom through the cavity.

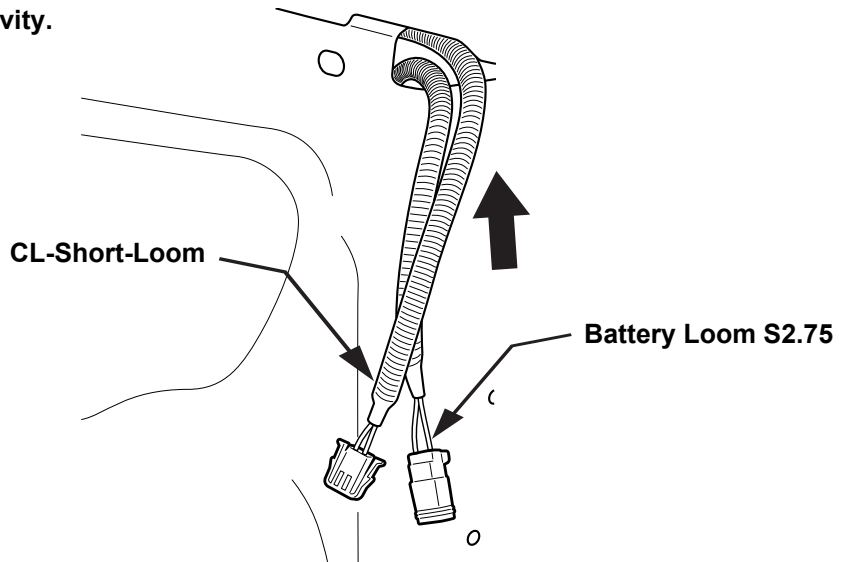

Remove required clips and cover to gain access to fuel flap actuator loom.

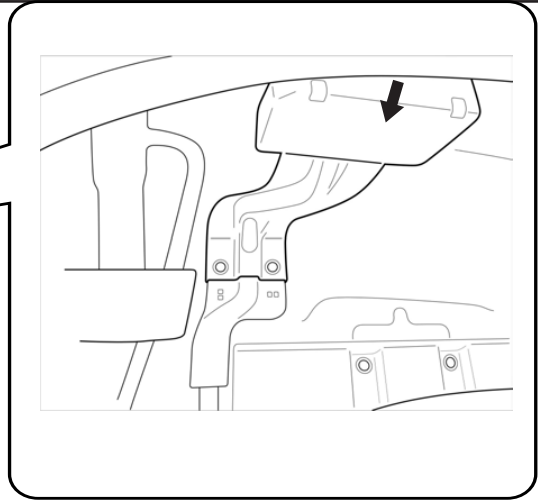
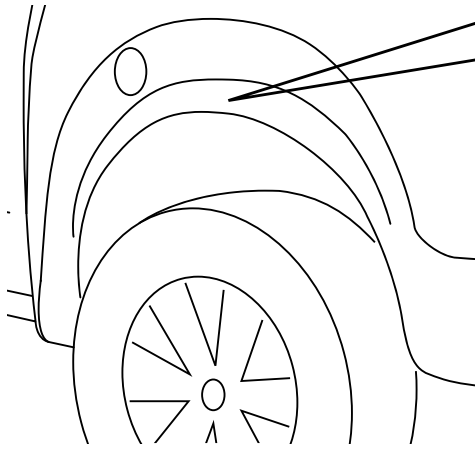

- 1) Plug NN-PATCH wiring.
- 2) Plug CL-LOOM-SHORT wiring.

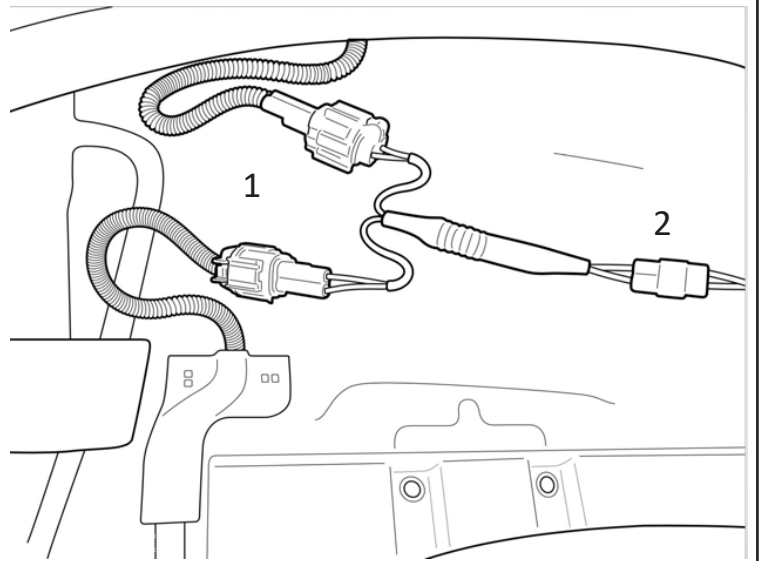

Cable tie overhang of wiring and re-fit the cover removed earlier.

1. Clear area with non oil based cleaner, ie alcohol wipe.
2. Apply clear protective tape to left and right top corners of the tailgate as indicated.

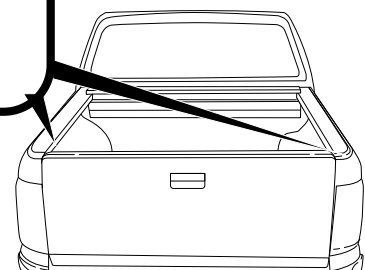
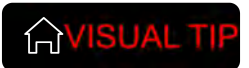
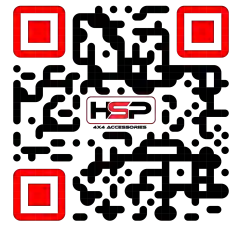
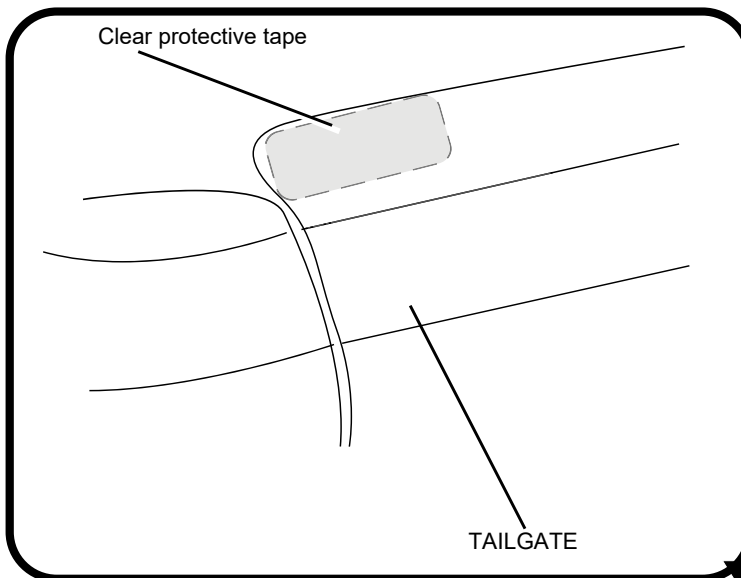

keep the cannister in the foam blocks from the packaging for assembly.

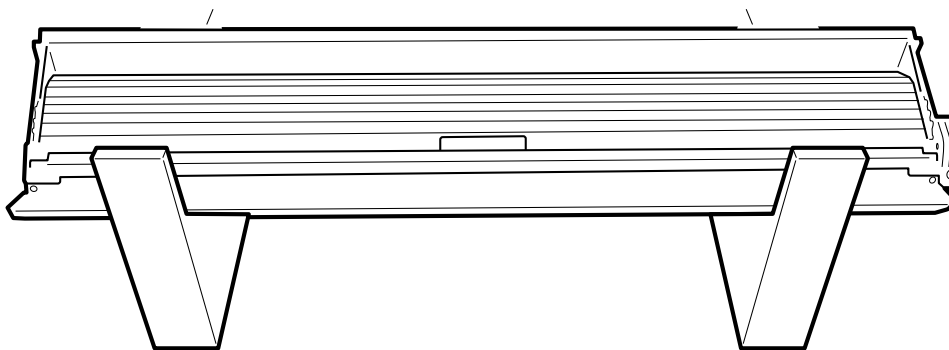
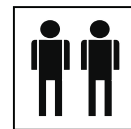

With assistance turn the canister on its back on the foam blocks.

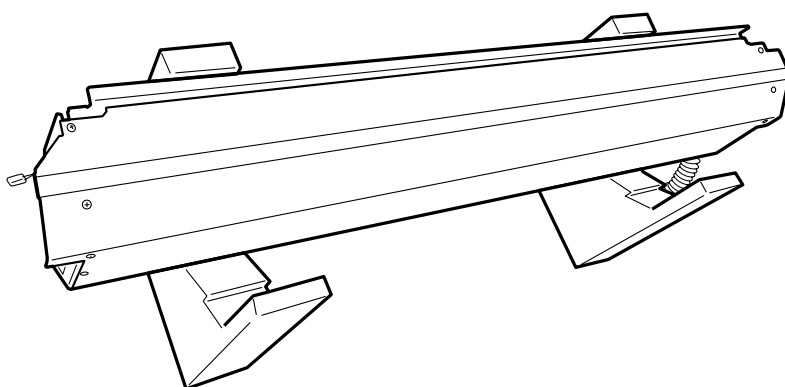
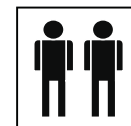

Disengage motor from the axle by unfastening the 3 Screw as indicated. Retain all parts.

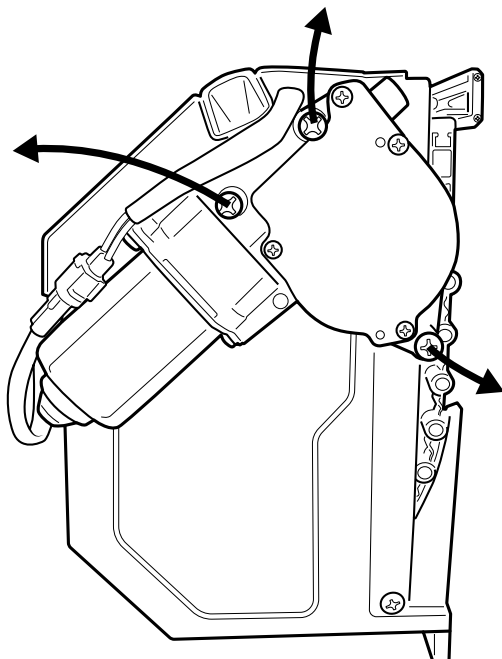

Remove and retain the 3 screw from the canister as indicated.

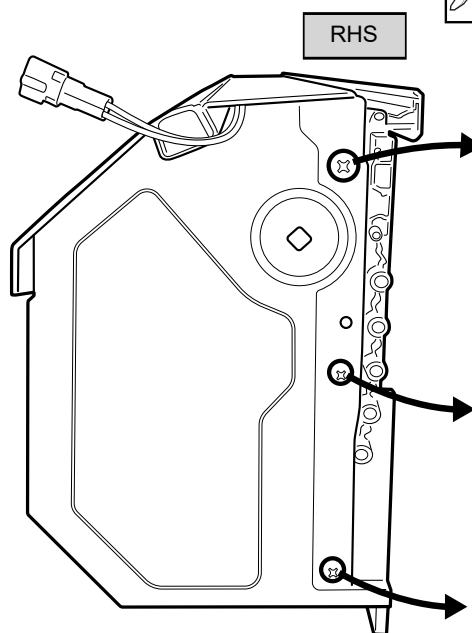
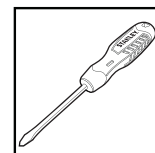

ATTENTION: Motor to remain off until both side rails are installed to the canister.

Now on the other side, remove and retain all 4 screws, spring washers and flat washers from the canister as indicated.

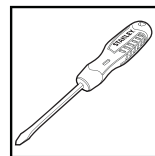
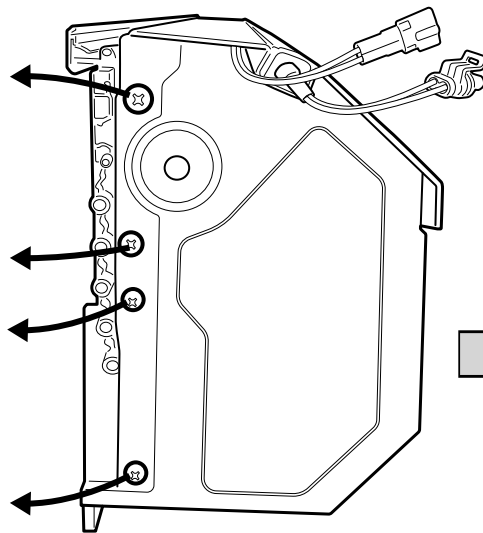

Align side rail to side of canister, guide the track to go in between the curtain end robber stop.

NOTE: LHS side rail to be assembled first.

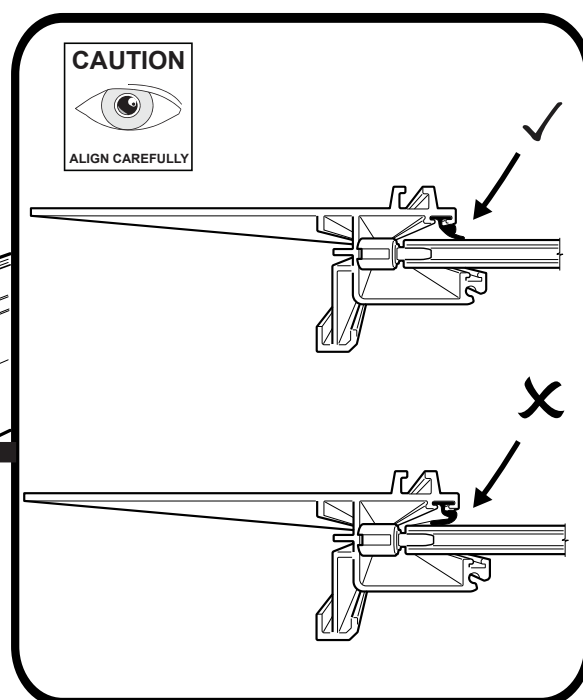
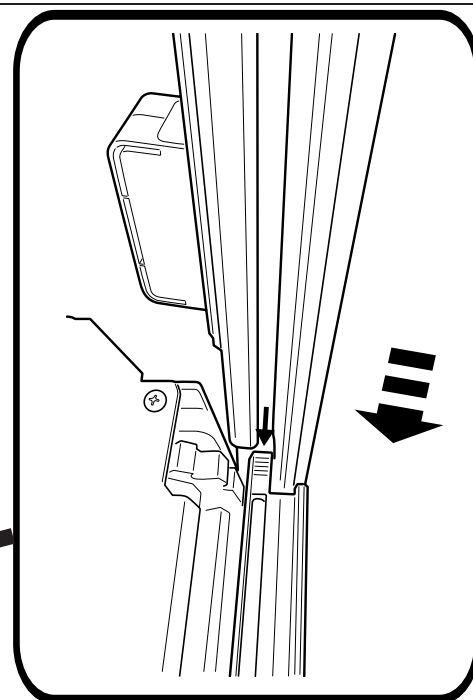
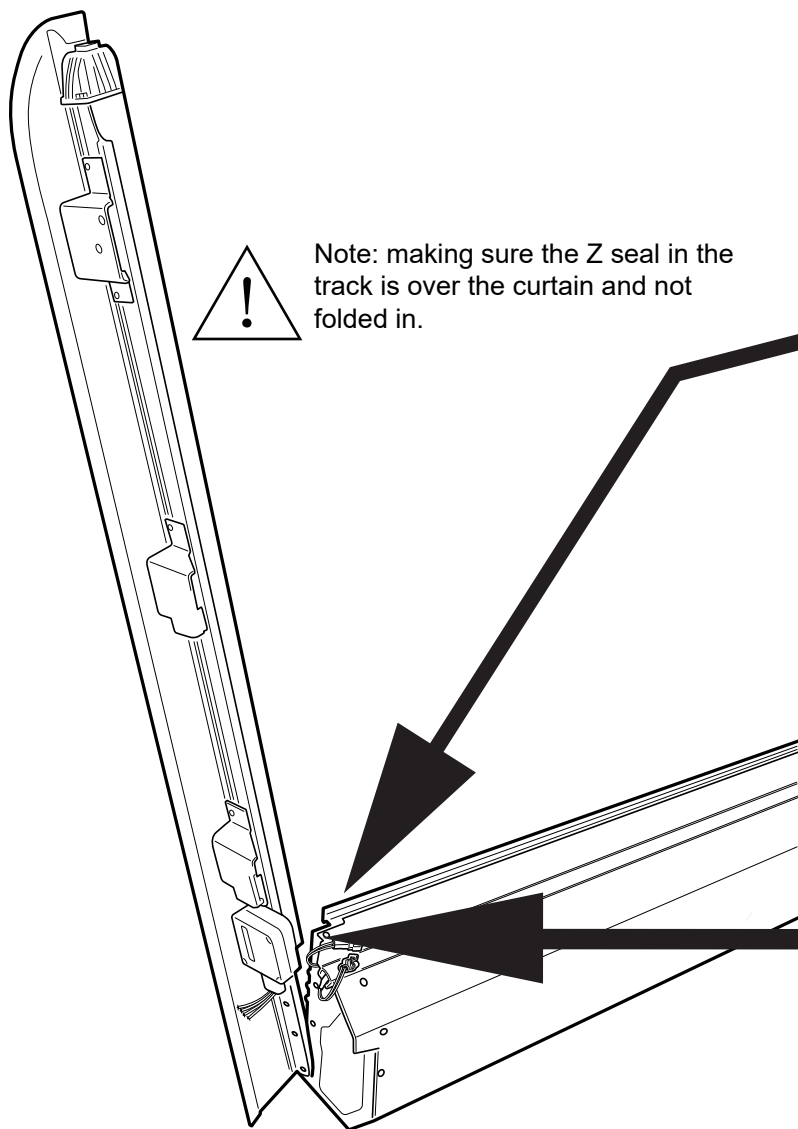

1. Using the retained screws, spring washer and washer, Loosely fasten the side rail to the location indicated.
2. Side rail edge must compress and meet with the canister profile as indicated below.
3. Fasten all screws tight.

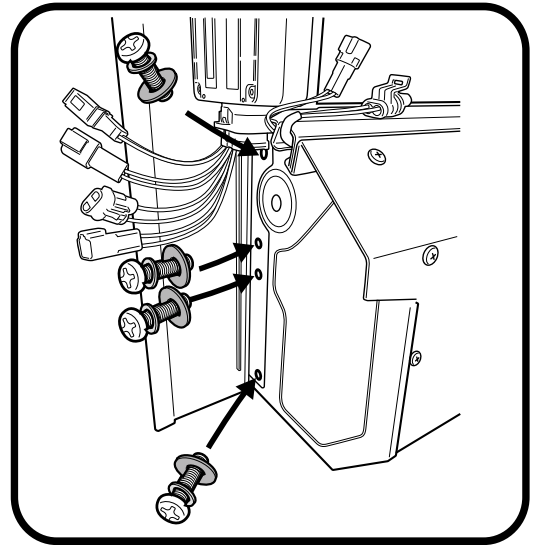
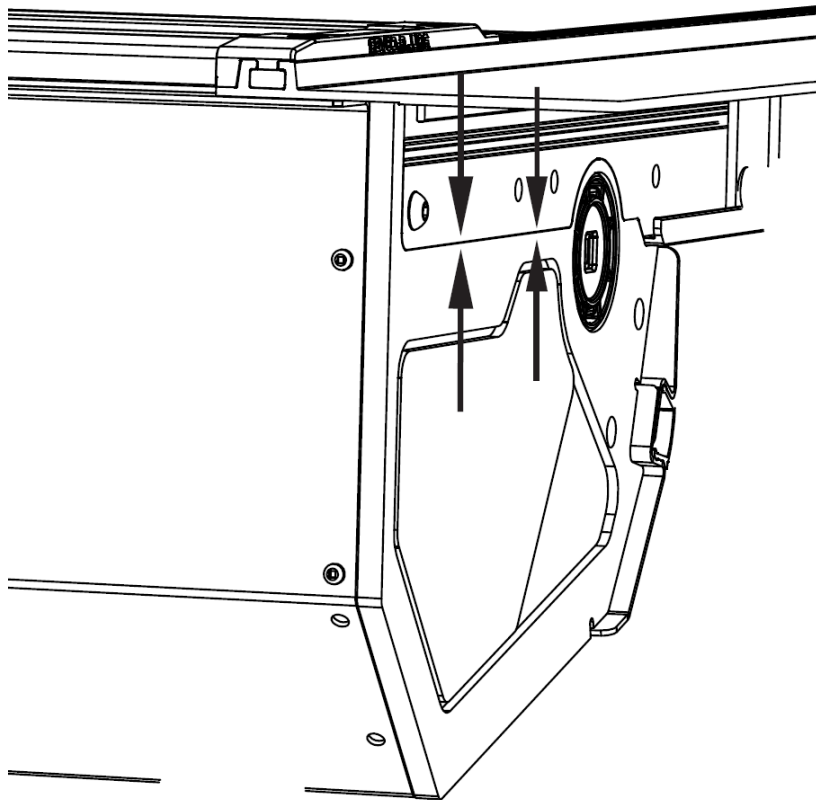
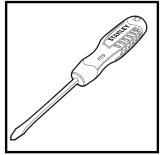

Connect motor connector to receiver

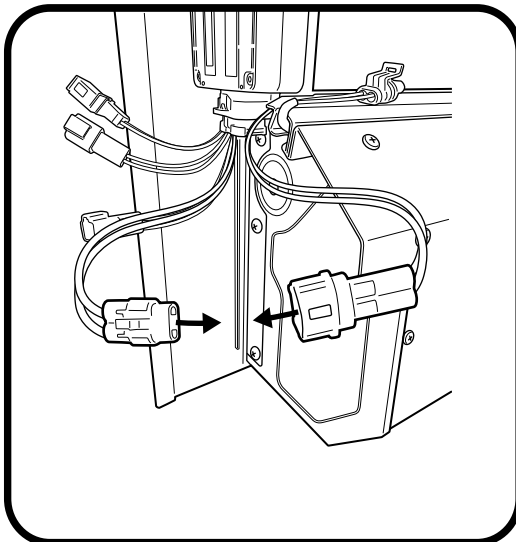

Connect LED Loom to receiver

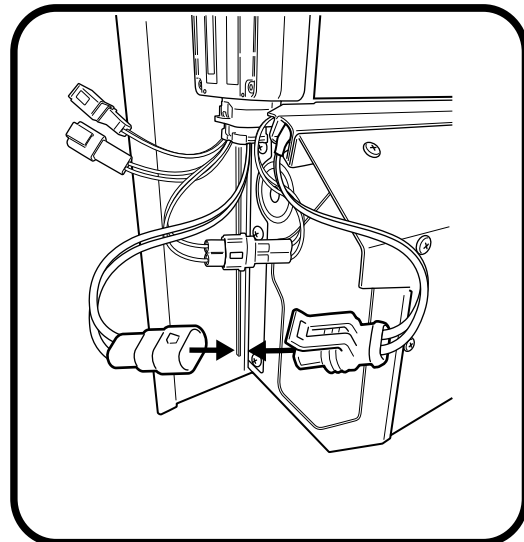

Align side rail to side of canister, guide the track to go in between the curtain end robber stop.

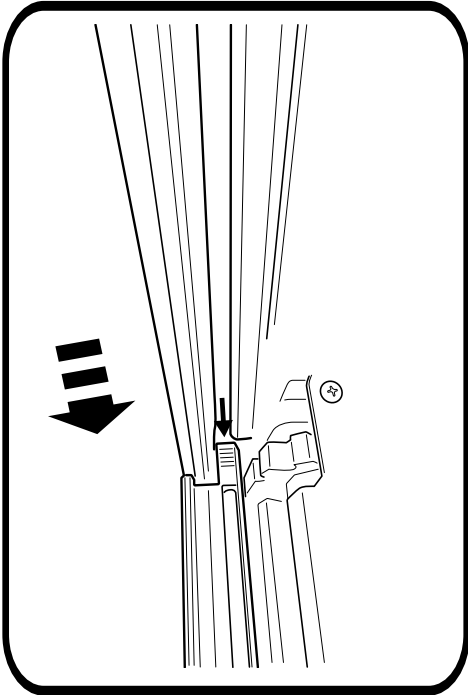

Note: making sure the Z seal in the track is over the curtain and not folded in.

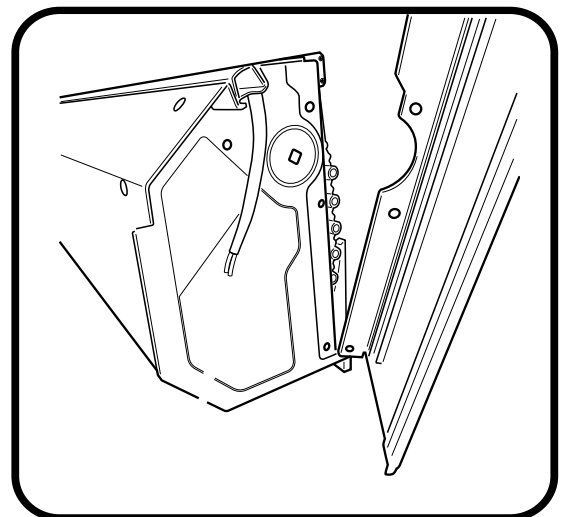
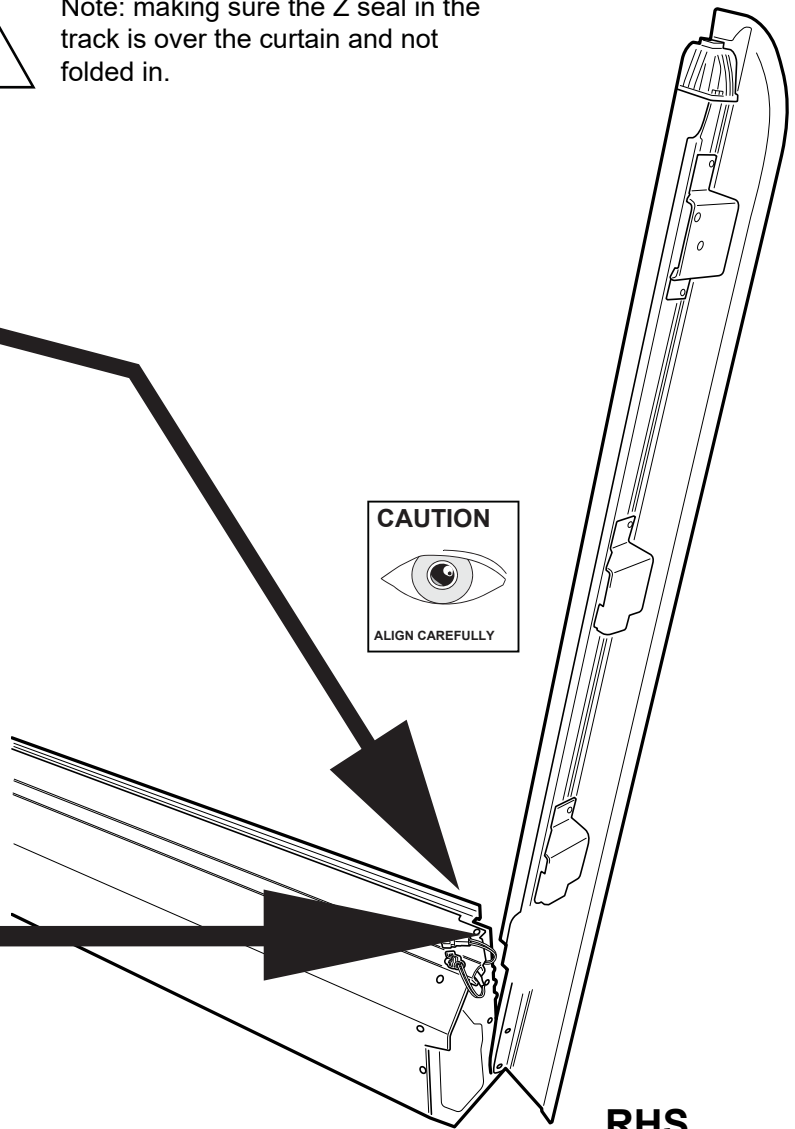
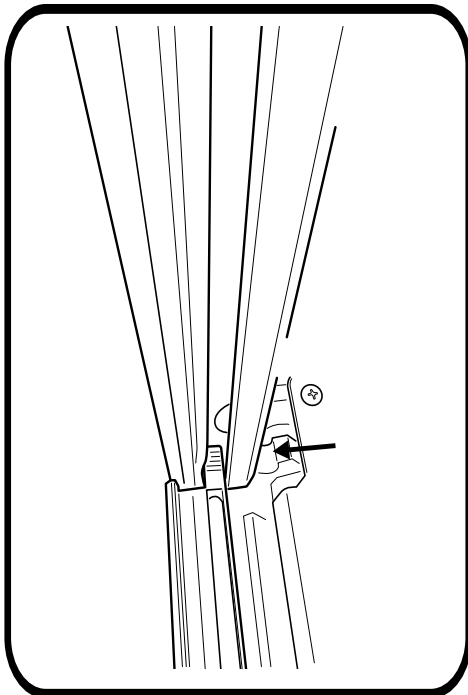

1. Using the retained screws, spring washer and washer, Loosely fasten the side rail to the location indicated.
2. Side rail edge must compress and meet with the canister profile as indicated below.
3. Fasten all screws tight.

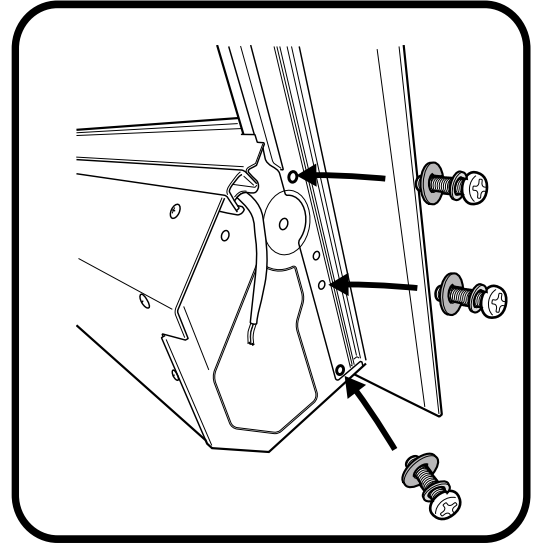
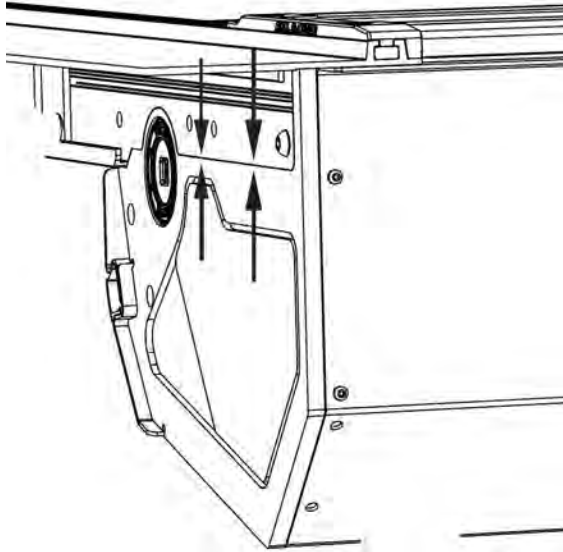
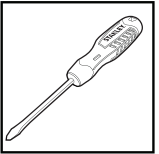

Feed M6 bolt through spring washer, motor and rubber bush.

NOTE: Rubber bush orientation has to be as per image. (side with text on rubber, to face the motor).

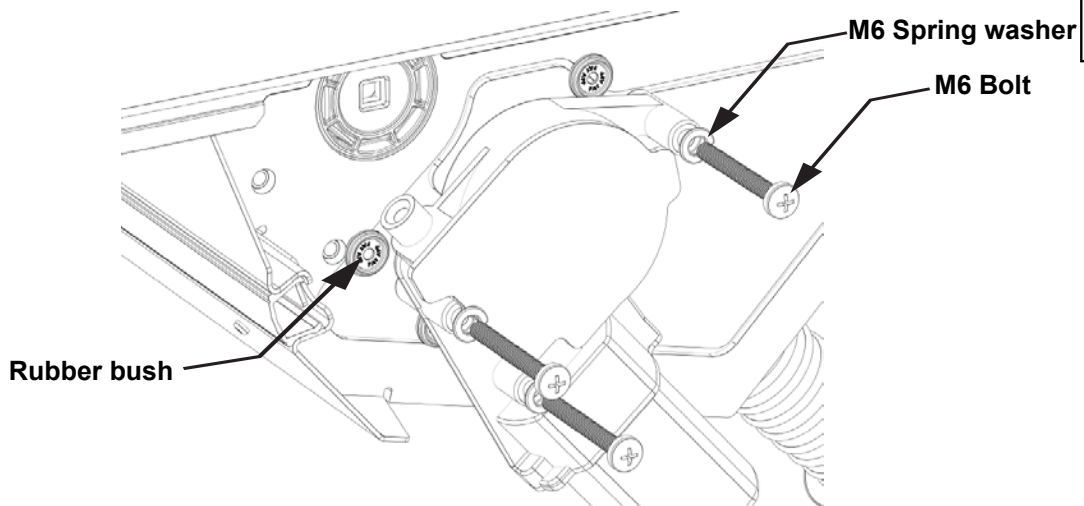
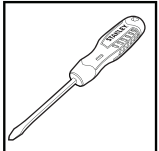

Align & insert motor shaft to axle.

NOTE: Pull / push curtain for axle to rotate.

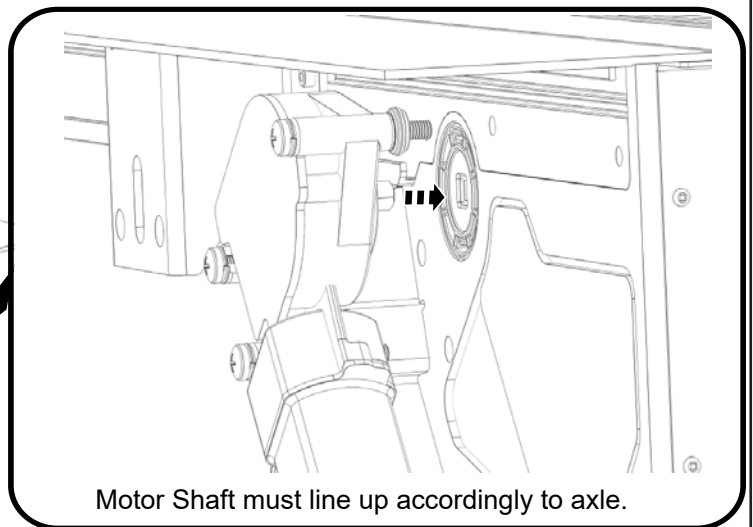
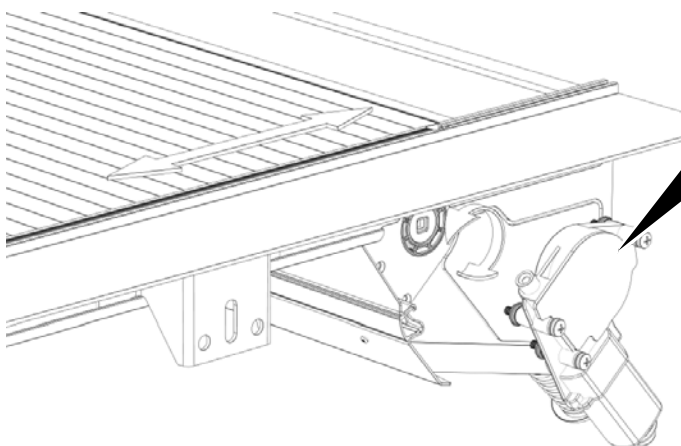

Motor Shaft must line up accordingly to axle.

Fasten all 3 screws to 2nm torque. Over tensioning will cause operating issue's.

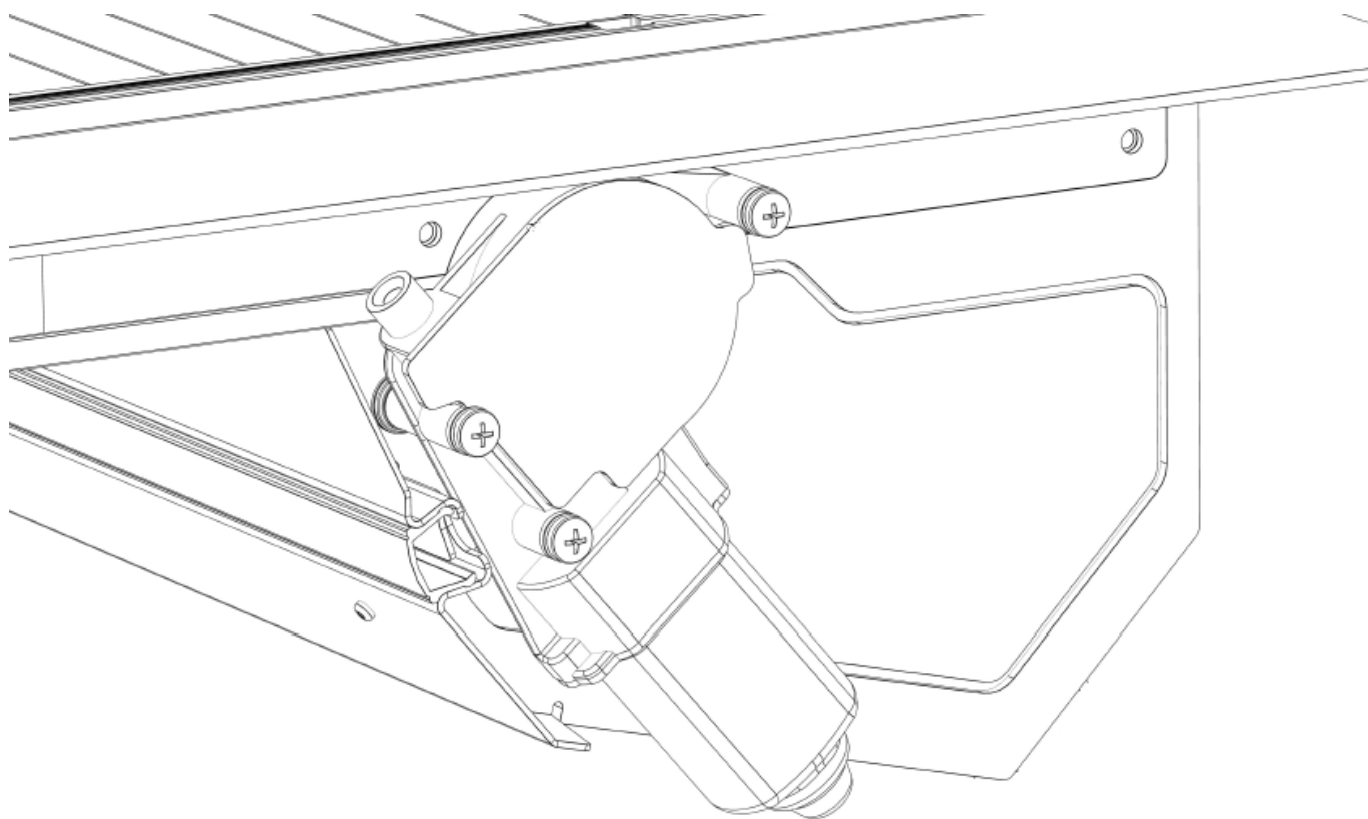
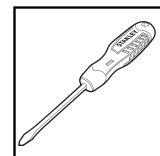

Motor is to sit level.

Any obstructions between motor and canister may cause operating issues.

Carefully bring down the assembled unit.
If side seal on the side rails has moved, carefully bring back into position.

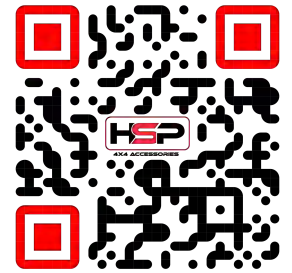
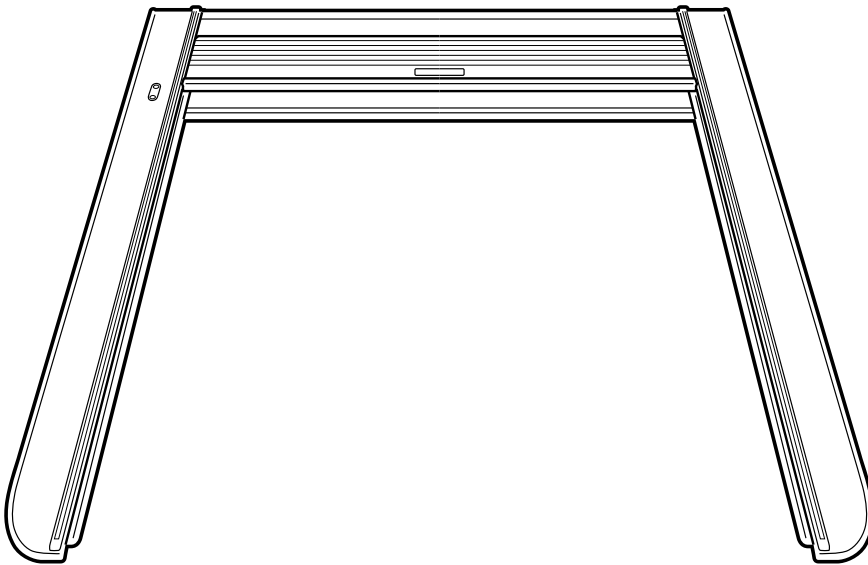

Insert side end caps to the top cover.

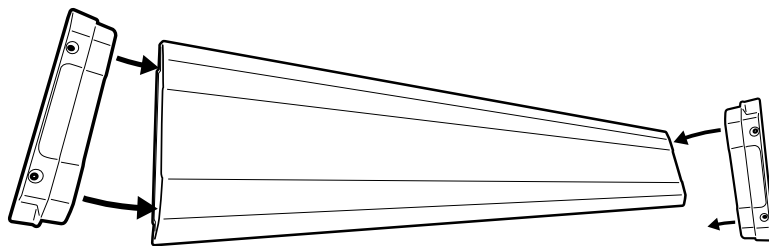
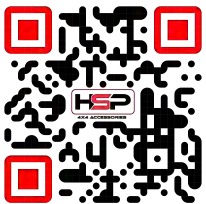

Place & Align top cover over the canister and side rails.

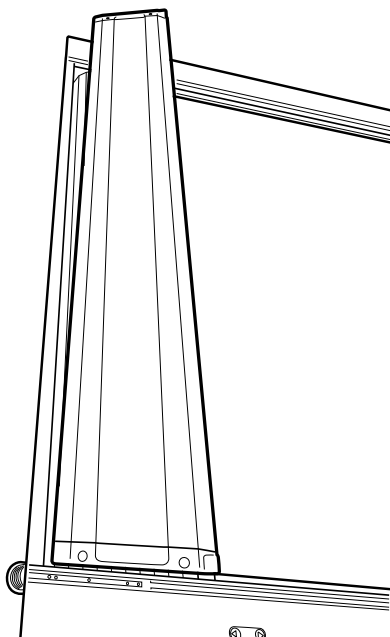

Using countersunk screws provided, line up end cap holes to the threads on the side rail.
Fasten to 3nm torque. Repeat to the other side.

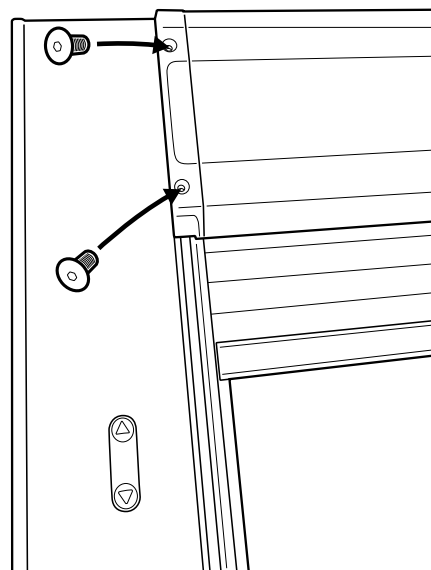

Apply supplied 3M primer around all side rail holes.

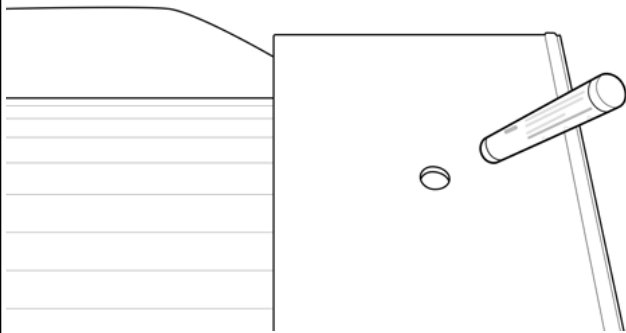

Drivers side holes.

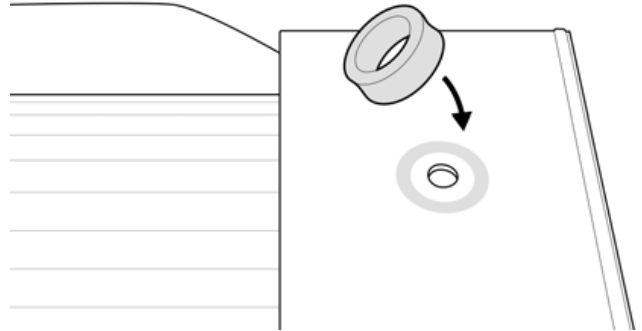

Peel away backing from foam sealant and stick to side rail. Note: round seals are for drivers side rail only.



Passenger Side seal.

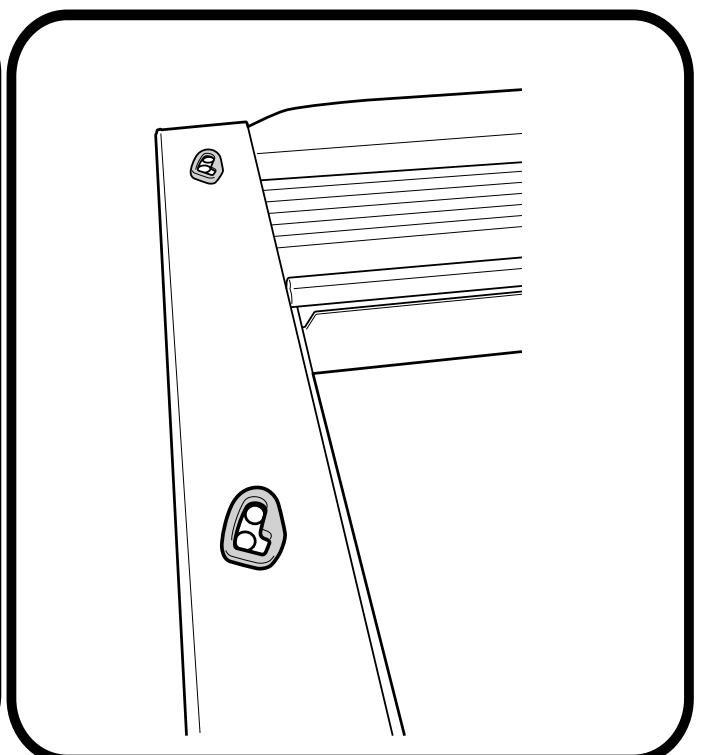
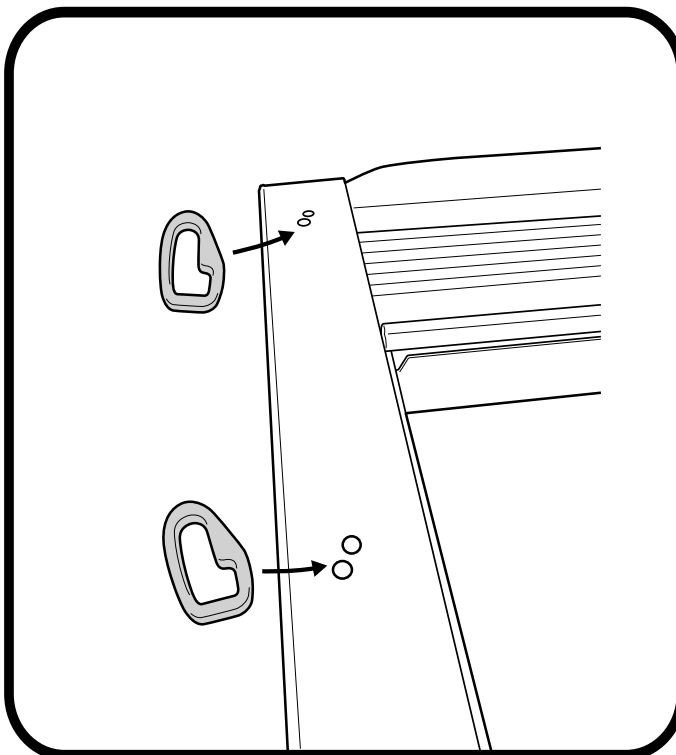

Place the sports bars on a protective matt.

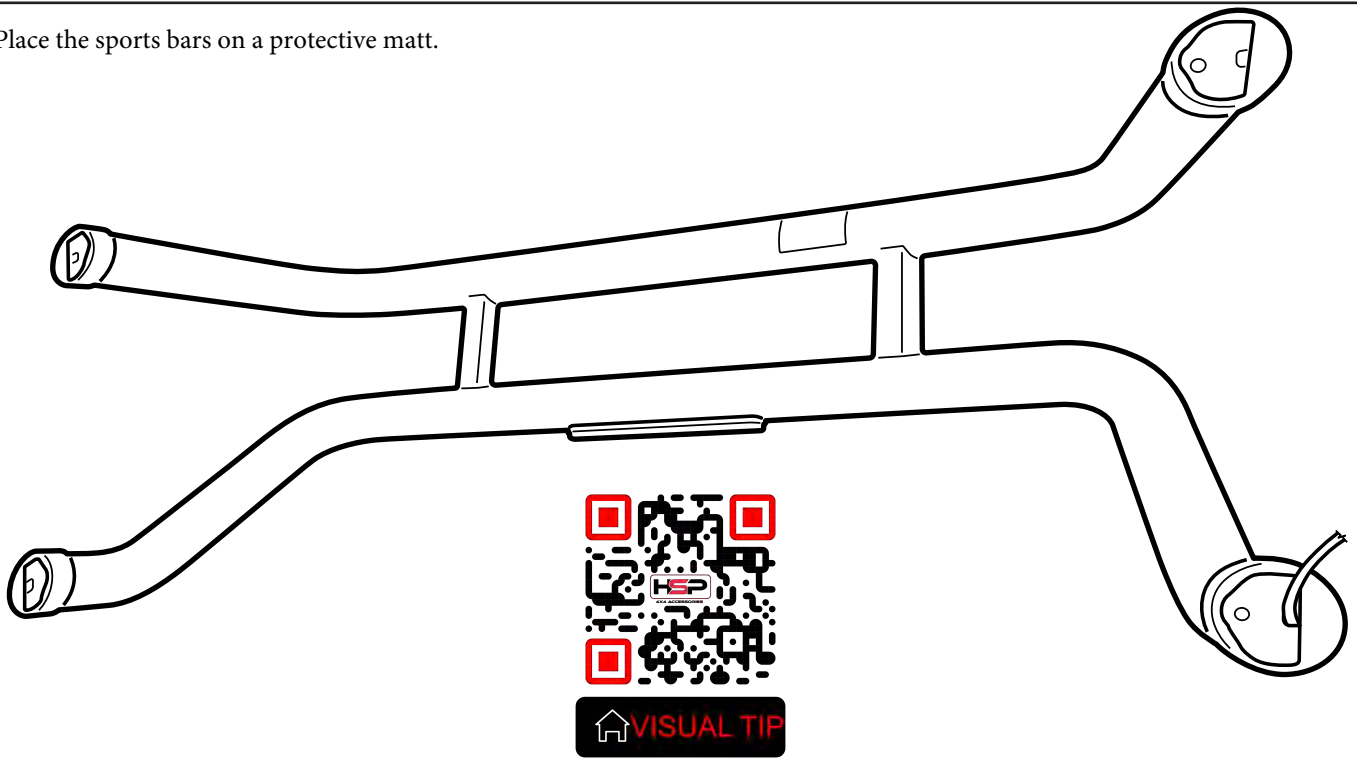

Fasten part number 704 (sports bar adapters) to the front legs of the sports bars.

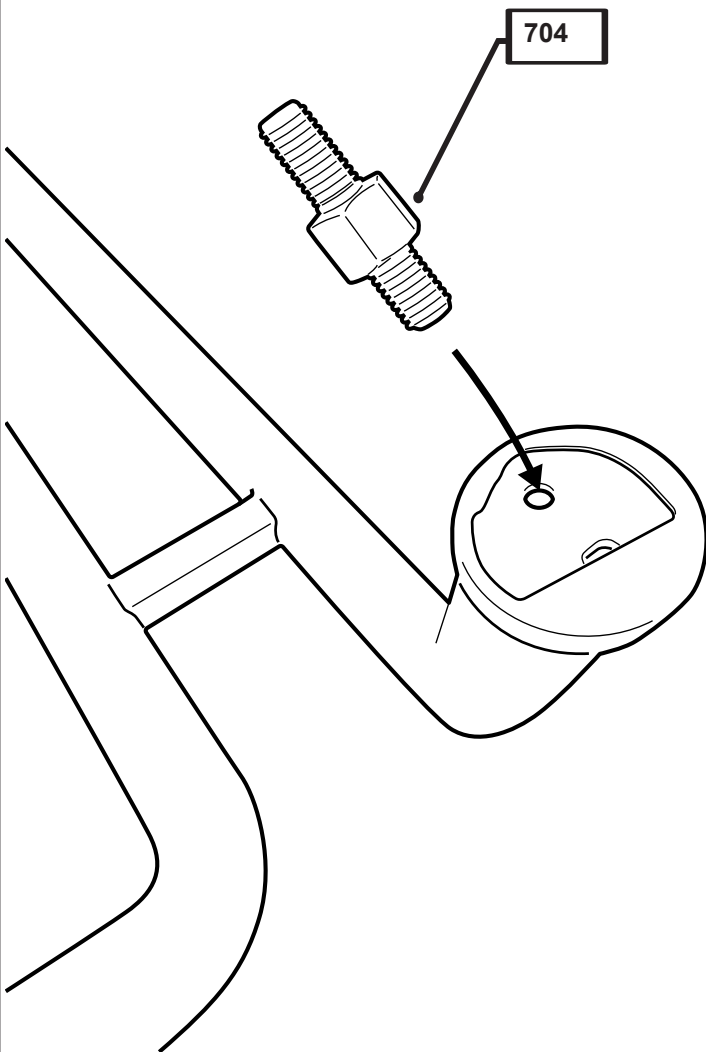

Fasten part number 705 (sports bar adapters) to the rear leg of the sports bars.

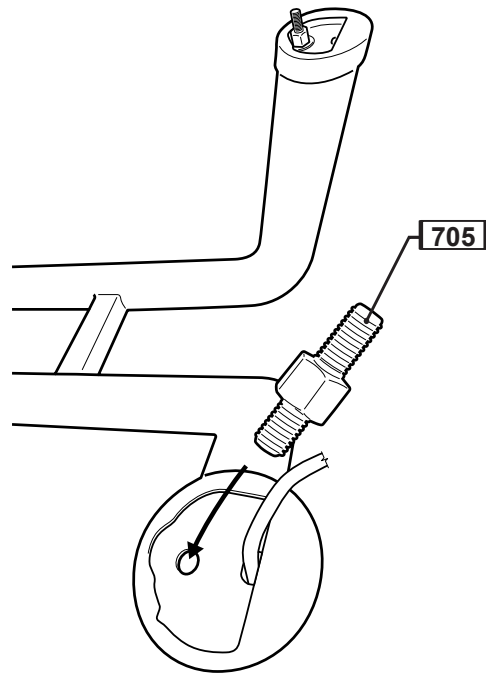

Place Sports bar on Roll R cover

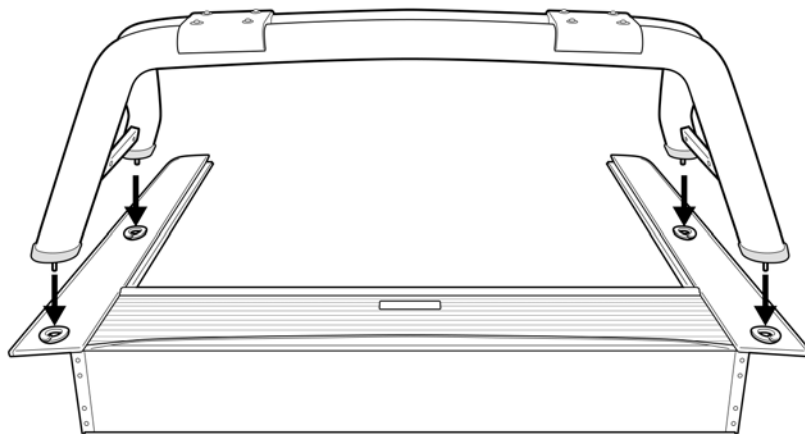
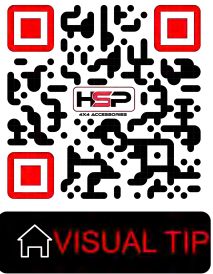

Fasten into position using supplied M10 flat washer and M10 nyloc nut.

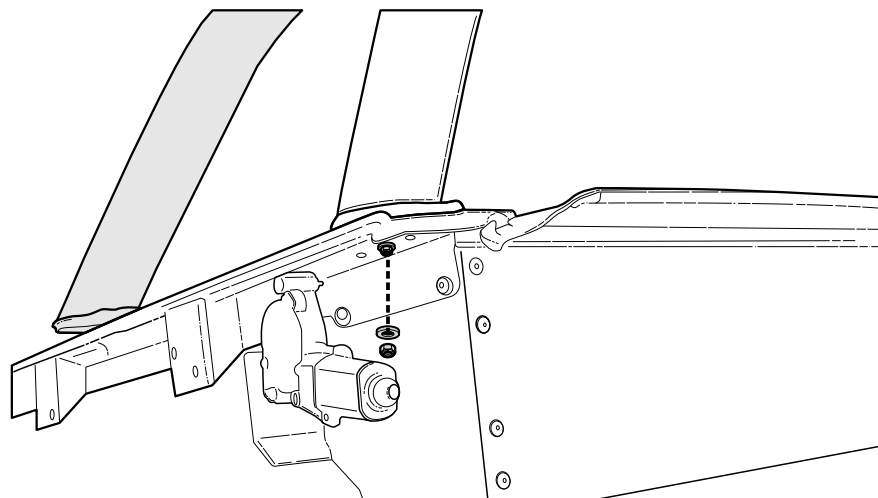

Note - Do not overtighten

Place the Roll-R-Cover unit on to Ute bed.

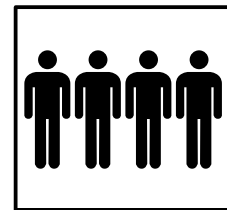
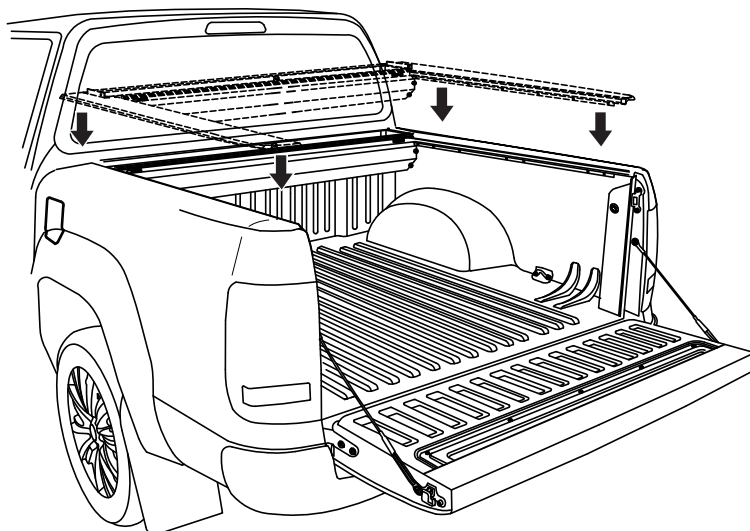

4 People
Recommended for lift

With care, pull out any side rubber
that has folded under the side rail.

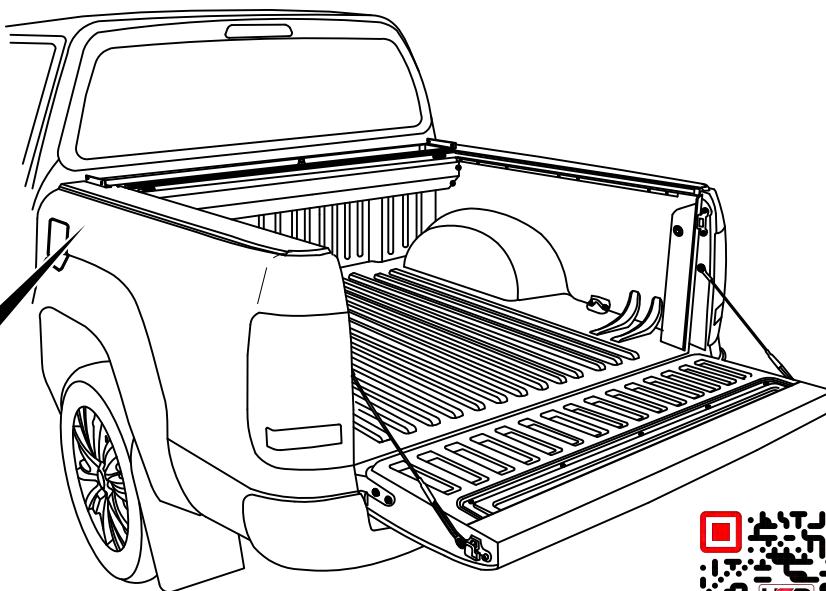
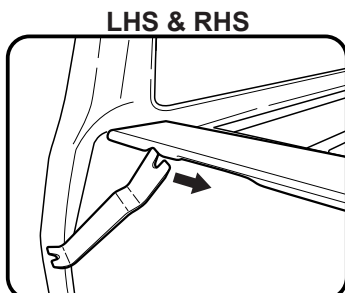

To the locations indicated below position clamp behind the inner top lip of the bed rail and the center elongated hole of the side rail mounting brackets. Repeat to other side.

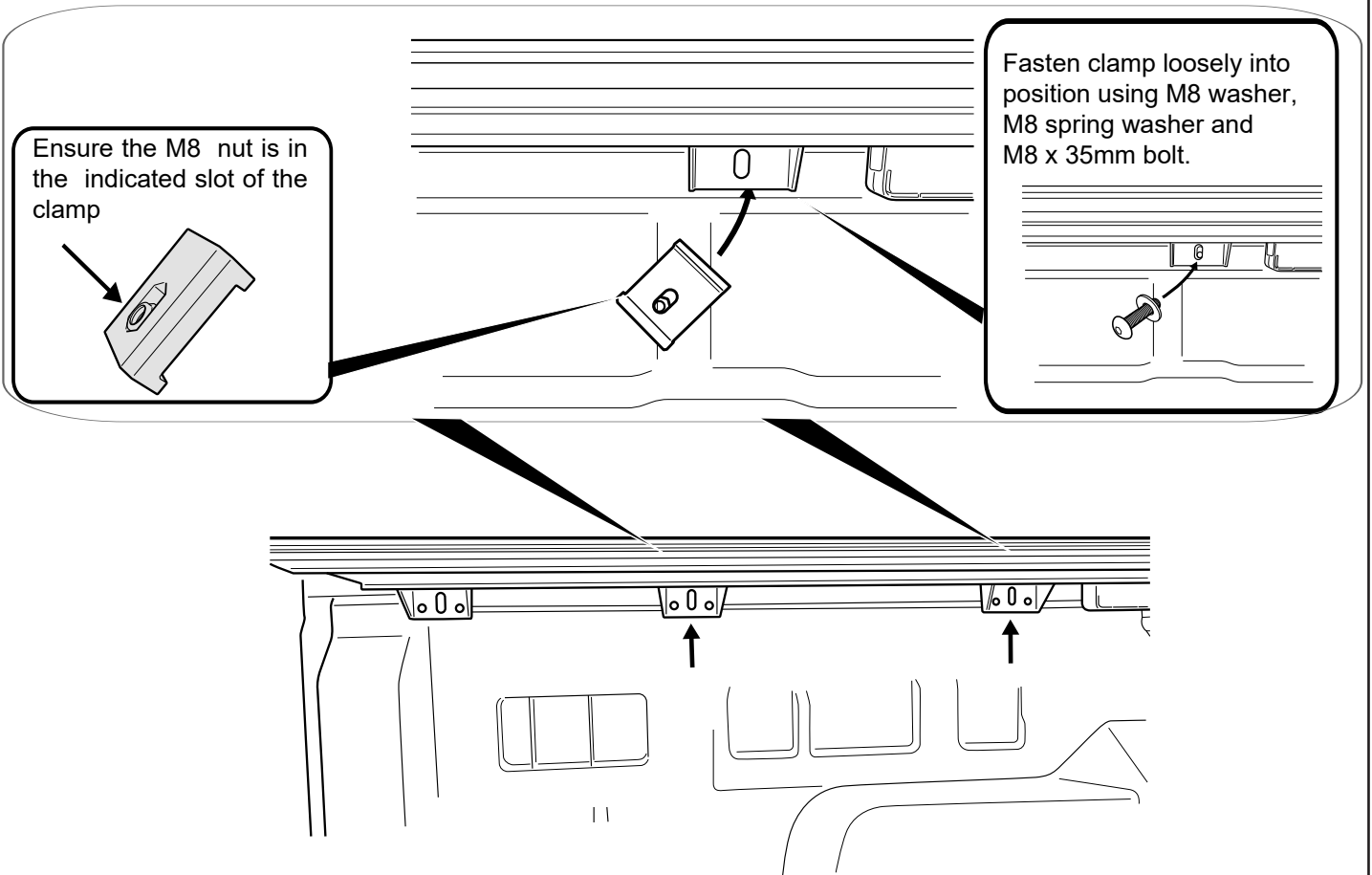

To the locations indicated feed M8x35mm button head bolt through M8 washer, side rail bracket and rear previously fitted tub bracket.

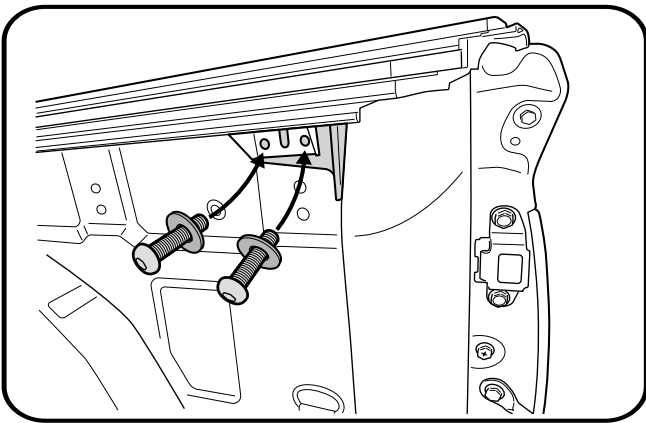

Place M8 washer behind tub bracket and through M8 bolt.

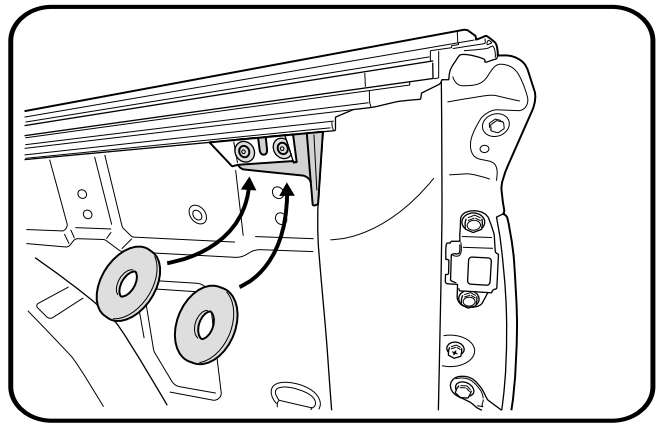

loosely fasten nuts to M8 bolt.

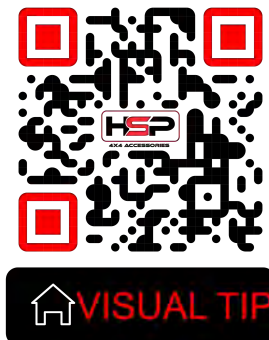
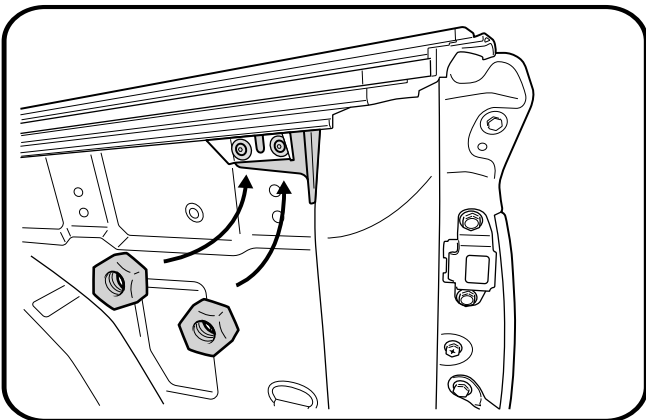

 VISUAL TIP

Repeat to other side.

With the tailgate up (Closed position), Pull left & right hand side rails towards the tailgate, stopping short by 5mm between tailgate and side-rail end-cap. Repeat to other side.

5mm



VISUAL TIP



Foam compressed to 5mm when tailgate is closed.

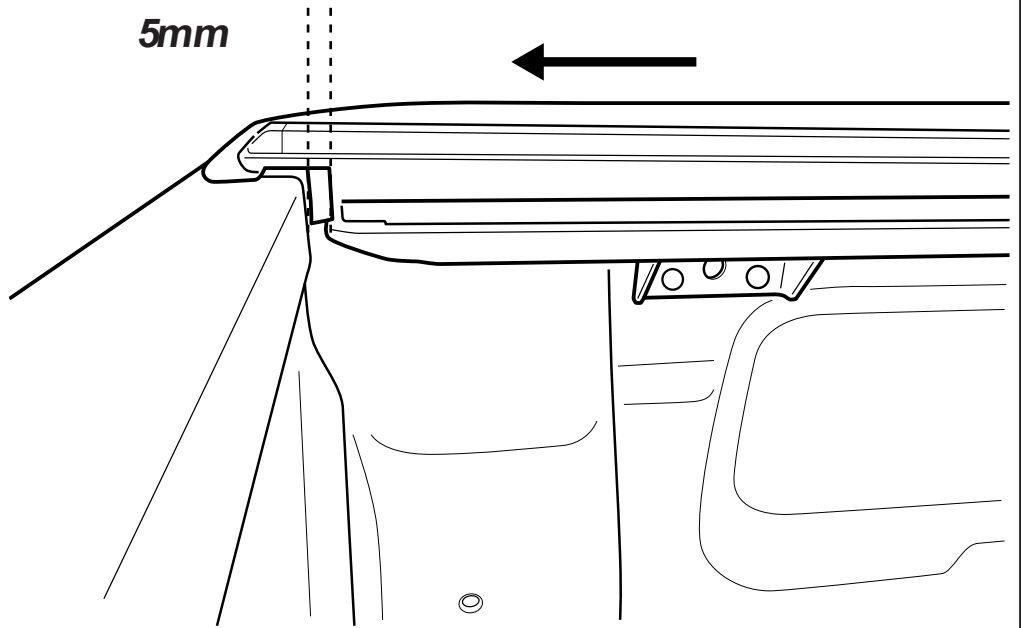

Gap between tailgate and side-rail end cap to be 5mm.

Foam seal

Side rail end cap

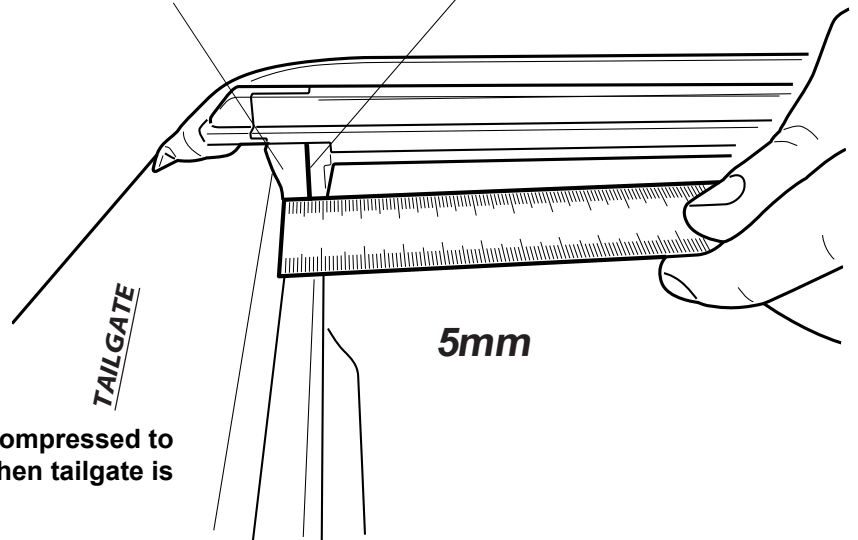

Foam compressed to 5mm when tailgate is closed.

Fasten M8 button head bolt and nyloc nut to 10Nm torque. Repeat to other side.

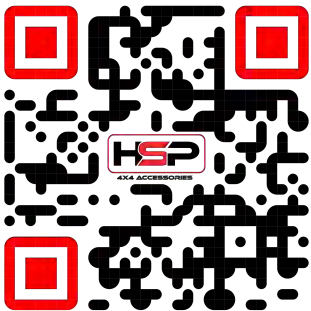

VISUAL TIP

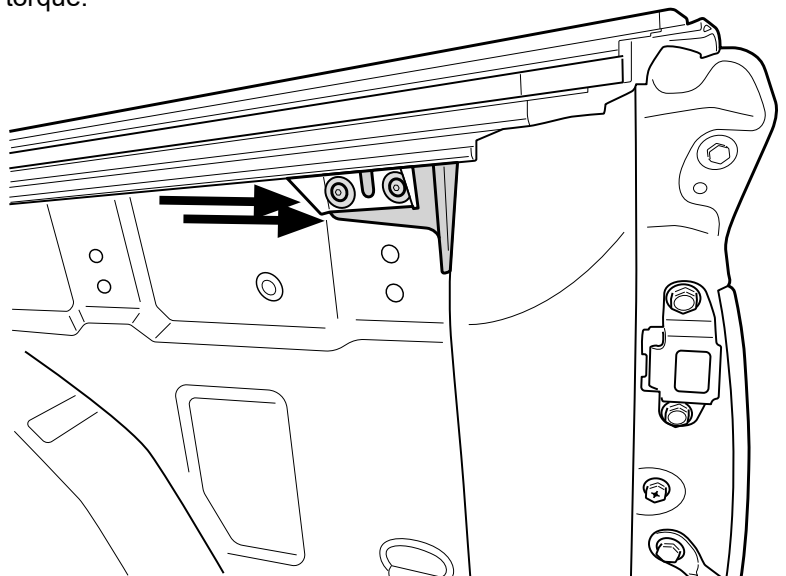

Slightly loosen indicated bolts to allow movement in the bracket.
Repeat to other side.

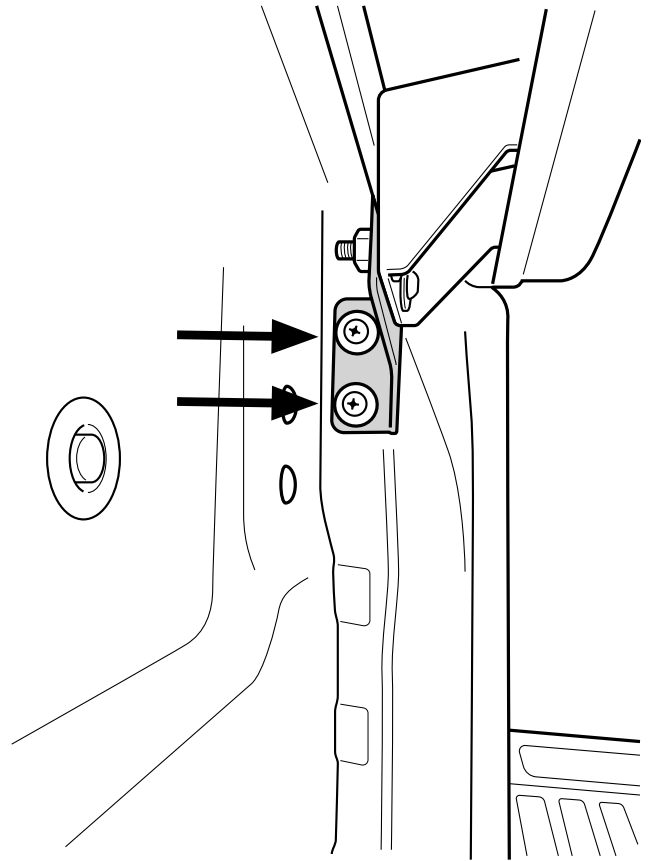

1. Gently push down where indicated so the side seal of the side rail folds on top of the tailgate by 1-2mm.
2. Push rail out as far as possible towards the outside of the tub.
3. Hold both positions in place.

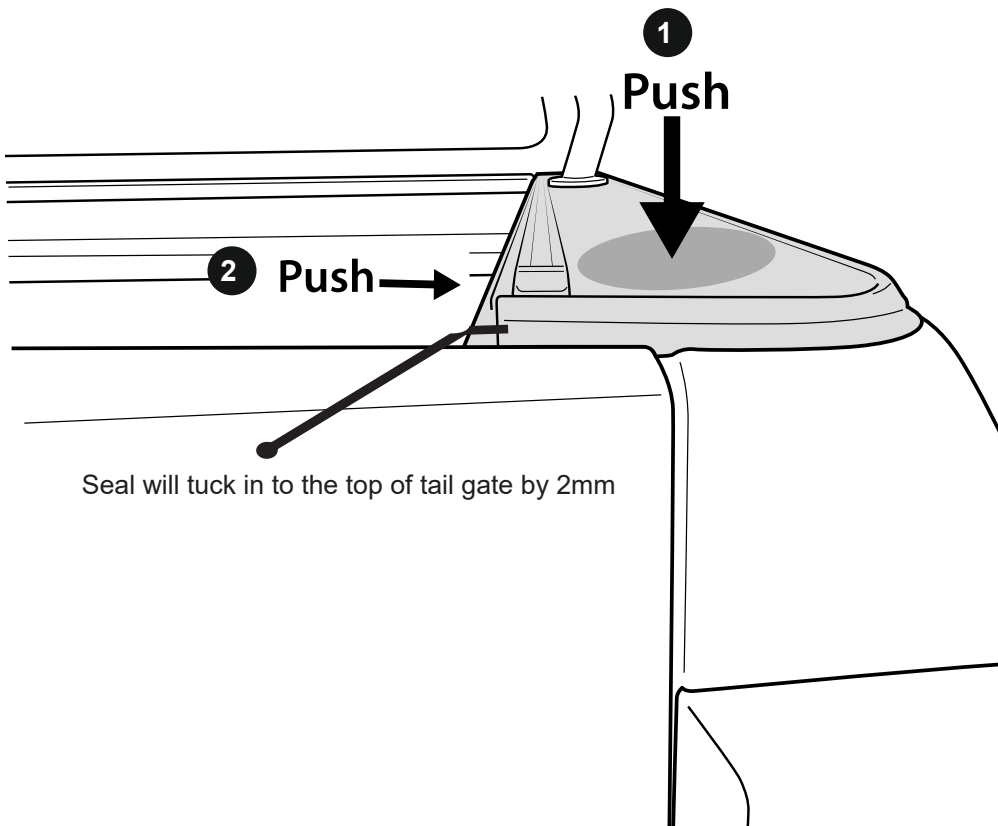

With position of side rail held in place in the previous step, fasten the indicated button head bolts to 6Nm torque.

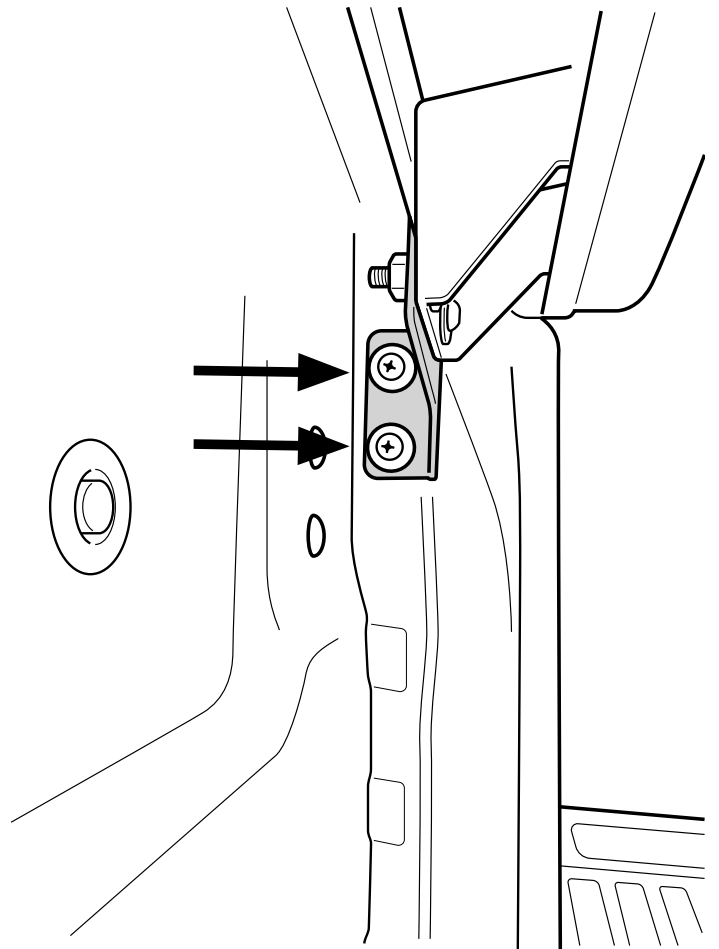

1. Apply downward pressure on side rails.
2. Lift **clamp** all the way up or as far up as possible then fasten clamp to 10Nm torque in the order indicated below.

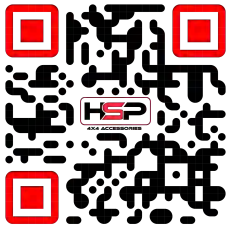

 **VISUAL TIP**

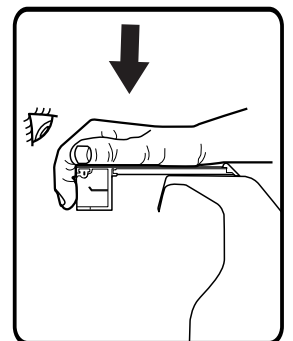
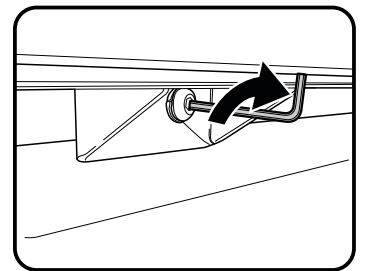
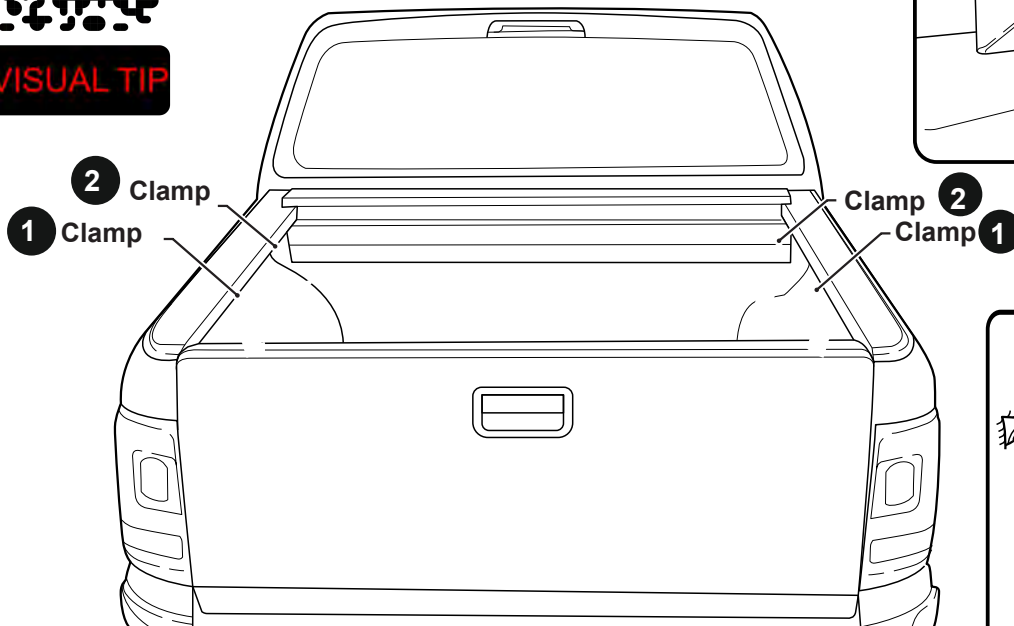

Install front drain pipes through pre-drilled holes of the canister. (RHS/LHS)



Note: With care push tube in.
Taking care pull the tube back
so it seals correctly against
the front panel of the tub.

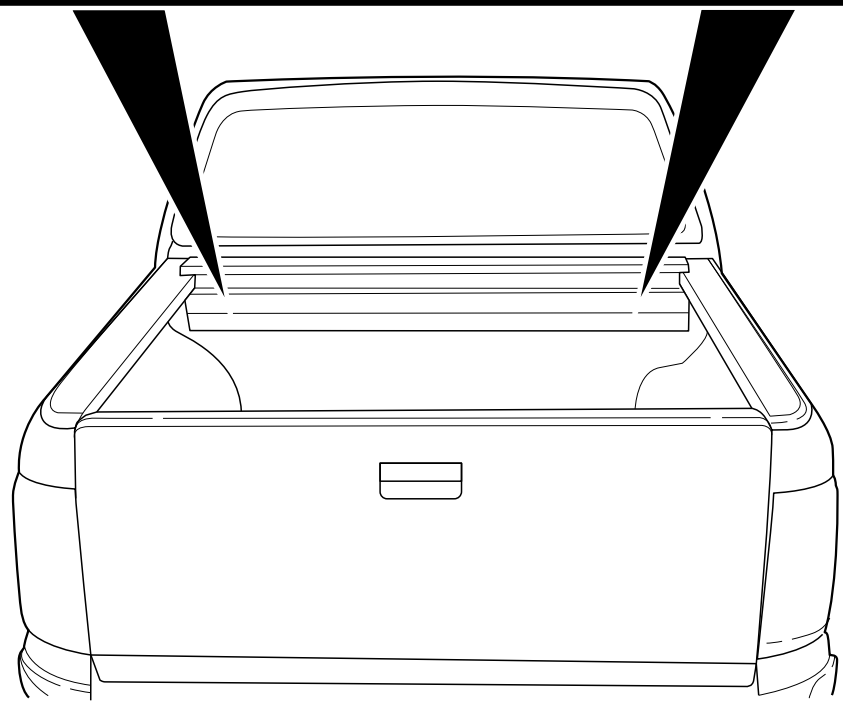
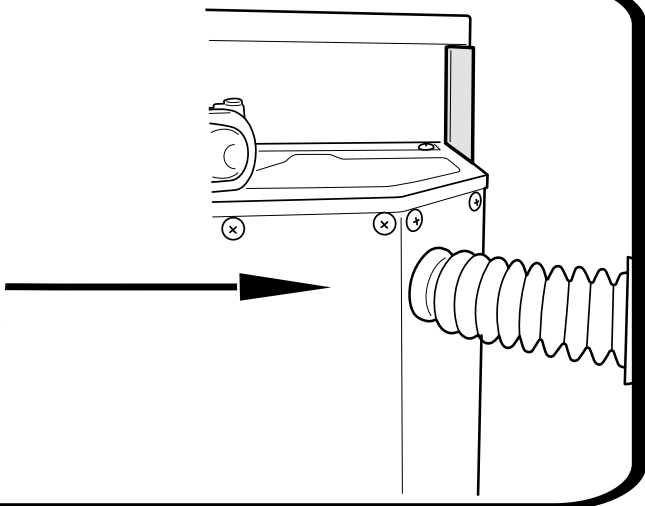
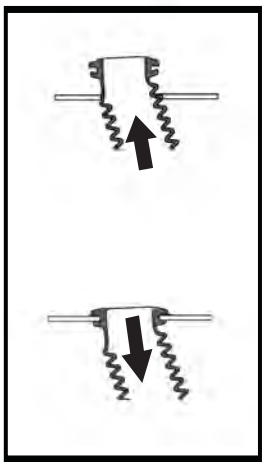

 VISUAL TIP

- a. Connect Battery loom S2.75 to Receiver loom.
- b. **Carefully** connect CI-Loom-short to Receiver loom.



Align connectors
carefully to avoid
pushing pins out.

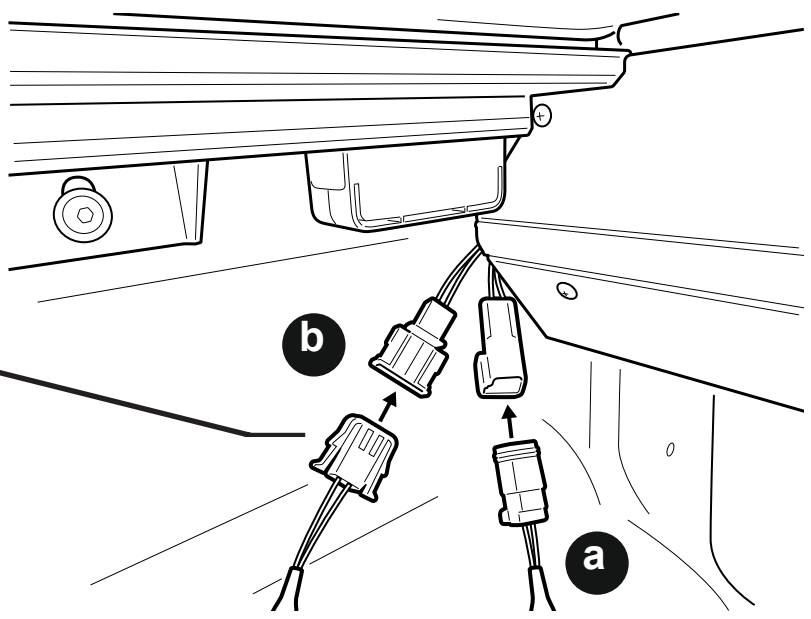



NOTE: 1. To wear in the Roll R Cover please fully open & close the cover approximately 15 times after install is complete.

2. Set your vehicle locking system to unlock all doors with one press of the factory remote unlock button. This setting can be found in your vehicle settings.

Operating instructions:

Press unlock on vehicle key fob to activate controller.

When vehicle is unlocked the side rail sensor buttons will be active to control.

When vehicle is locked the side rail sensor buttons will be inactive.

Using factory key fob to operate:

Pressing unlock twice on the factory key fob within 4 seconds, will activate the roll r cover to open.

Pressing lock twice on the factory key fob within 4 seconds, will activate the roll r cover to close.



Vehicle proximity:

Tapping the proximity twice to open or lock the car door will act exactly the same way as the key fob being pressed twice.

Touch & let go to open, touch & let go again to pause.

Touch & let go to close, touch & let go again to pause.

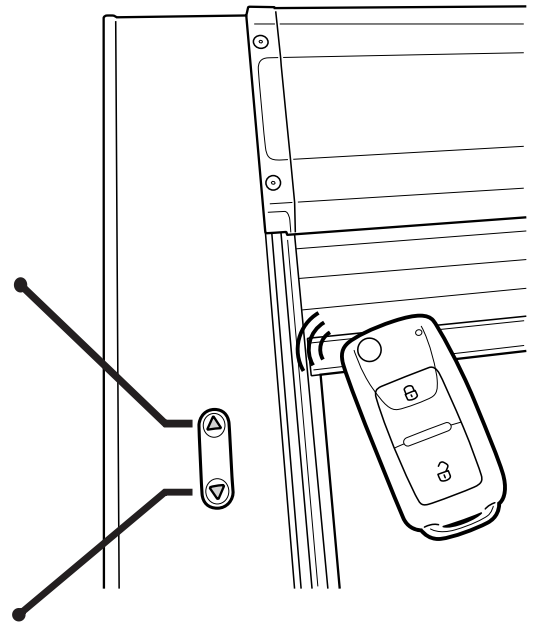

NOTE: You must service the unit before hand over, please scan the QR code to see how to service.



Trouble shooting visual tips:

side rail Parallel test

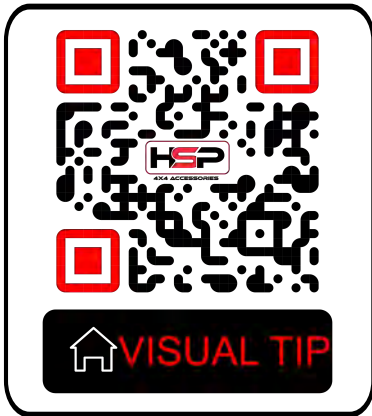

Ampage test and servicing

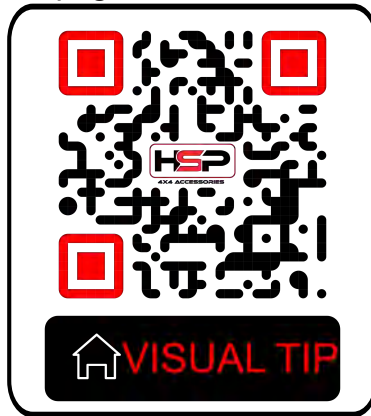

Emergency override

