

# Fitting Instructions Part Number VA100 SILVERBACK Lid VOLKSWAGEN AMAROK NEW GENERATION 2023+

*Check contents of kit before commencing fitment and report any discrepancies*

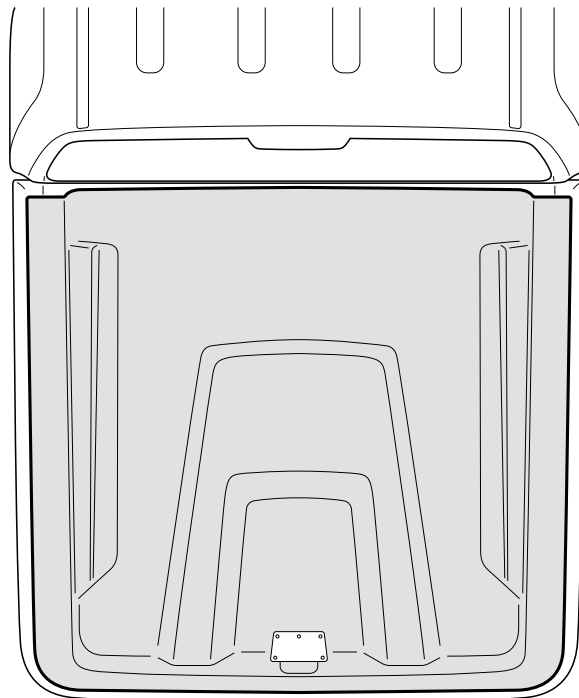

\*Image example shown only

<b>IMPORTANT</b>	<ul style="list-style-type: none"> <li>• Do not stand/sit or rest heavy objects on Tonneau Cover</li> <li>• Humans or animals are not to be under the closed Tonneau at any given time</li> <li>• Securely lock tonneau Cover before operating vehicle</li> <li>• Tonneau Cover is not dust or water tight</li> <li>• Do not carry open volatile chemicals with Tonneau Cover installed</li> <li>• If contact with volatile chemicals occur, clean Tonneau with mild detergent and water solution</li> </ul>			
<b>Care Instructions</b>	<ul style="list-style-type: none"> <li>• Read Instructions fully before commencing installation.</li> <li>• Clean Tonneau Cover with a mild detergent and water solution</li> <li>• Do not use abrasive cleaners or solvents</li> <li>• Refer to manufactures instructions applicable to power drill.</li> <li>• Protect Tub floor against scratches during installation process.</li> </ul>			
<b>Maintenance</b>	<p>If lubrication of the locks or hinges is required use only Graphite Powder. DO NOT use any other lubricants or oils.</p>			
<b>Tools Required</b>	<table style="width: 100%; border: none;"> <tr> <td style="vertical-align: top;"> <ul style="list-style-type: none"> <li>• Pen / Marker</li> <li>• Centre Punch</li> <li>• Drill &amp; Drill bits</li> <li>• Phillips head screwdriver</li> <li>• Caulking Gun</li> <li>• Silicon - Non Acetic</li> </ul> </td> <td style="vertical-align: top;"> <ul style="list-style-type: none"> <li>• Die Grinder &amp; multi tool</li> <li>• Masking Tape</li> <li>• Scissors &amp; Knife</li> <li>• Ruler</li> <li>• Spanner &amp; Socket</li> <li>• Tape measure</li> </ul> </td> <td style="vertical-align: top;"> <ul style="list-style-type: none"> <li>• Soapy water solution</li> <li>• Allen Key set (Metric)</li> </ul> </td> </tr> </table>	<ul style="list-style-type: none"> <li>• Pen / Marker</li> <li>• Centre Punch</li> <li>• Drill &amp; Drill bits</li> <li>• Phillips head screwdriver</li> <li>• Caulking Gun</li> <li>• Silicon - Non Acetic</li> </ul>	<ul style="list-style-type: none"> <li>• Die Grinder &amp; multi tool</li> <li>• Masking Tape</li> <li>• Scissors &amp; Knife</li> <li>• Ruler</li> <li>• Spanner &amp; Socket</li> <li>• Tape measure</li> </ul>	<ul style="list-style-type: none"> <li>• Soapy water solution</li> <li>• Allen Key set (Metric)</li> </ul>
<ul style="list-style-type: none"> <li>• Pen / Marker</li> <li>• Centre Punch</li> <li>• Drill &amp; Drill bits</li> <li>• Phillips head screwdriver</li> <li>• Caulking Gun</li> <li>• Silicon - Non Acetic</li> </ul>	<ul style="list-style-type: none"> <li>• Die Grinder &amp; multi tool</li> <li>• Masking Tape</li> <li>• Scissors &amp; Knife</li> <li>• Ruler</li> <li>• Spanner &amp; Socket</li> <li>• Tape measure</li> </ul>	<ul style="list-style-type: none"> <li>• Soapy water solution</li> <li>• Allen Key set (Metric)</li> </ul>		

## PARTS CHECK SHEET

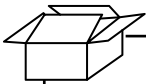

### PARTS IN MAIN CARTON

**100**

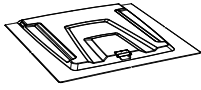

Tonneau Cover  
Qty - 1

**5**

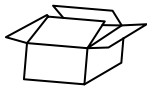

Fitting Kit  
Qty - 1



Fitting  
Instruction  
Qty - 1

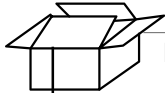

### PARTS IN FITTING KIT

**1178**



Lid Hinge  
Qty - 2

**S700-320**



Gas Strut  
Qty - 2

**1018**



Support  
bracket  
Qty - 2

**LHS BRACE**



FR22-  
SF-001-LH

**RHS BRACE**

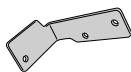

FR22-  
SF-001-RH

**BLK-S**



M6 x 20mm  
Pan Head Bolt  
Qty - 2

**BLK-W**



M6 black  
Flat Washer  
Qty - 2

**FR22-FBA**



FBA Bar with tabs  
and pins  
Qty - 1

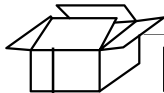

### Pack 01

**25**



M8x25 ALAN  
Head Bolt  
Qty - 8

**24**



M8 3mm thick  
Flat Washer  
Qty - 8

**19**



Self drilling  
screws Qty - 25

**23**



M8  
Hex Nut  
Qty - 8

**UB**



Striker U-Bolt  
Qty - 2

**42**



ALAN key  
Qty - 1



Alcohol wipe  
Qty - 1

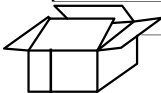

### Pack 03

**25**



M8x25 ALAN  
Head Bolt  
Qty - 12

**24**



M8 3mm thick  
Flat Washer  
Qty - 4

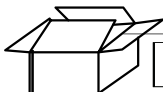

### Pack 05

**1048**

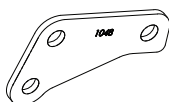

Strut body mount  
Qty - 2

**1189G-PS**

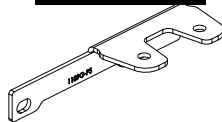

Striker  
Bracket L/H  
Qty - 1

**1189G-DS**

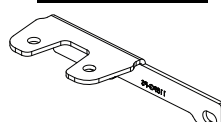

Striker  
Bracket R/H  
Qty - 1

**29**



Strut body mount  
Qty - 2

**40**



M8  
Nyloc Hex Nut  
Qty - 6

**NOTE: Instructions may refer to one side of vehicle, repeat steps to the other side.**

If the Vehicle is fitted with a headboard bar, remove from Ute Tub (truck bed).  
Note: Retain hardware.

**Sealing factory gaps on the bed. It is recommended to use black sealant.**

Apply an adequate amount of sealant to the areas indicated, then smooth sealant out.  
Clean any excess sealant. Repeat to the other side.

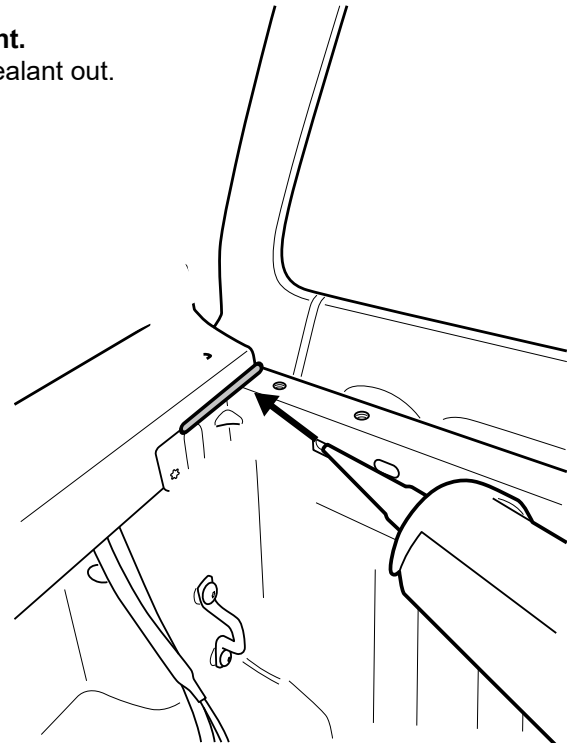

Place front bar assembly (FR22-FBA) over the head board.

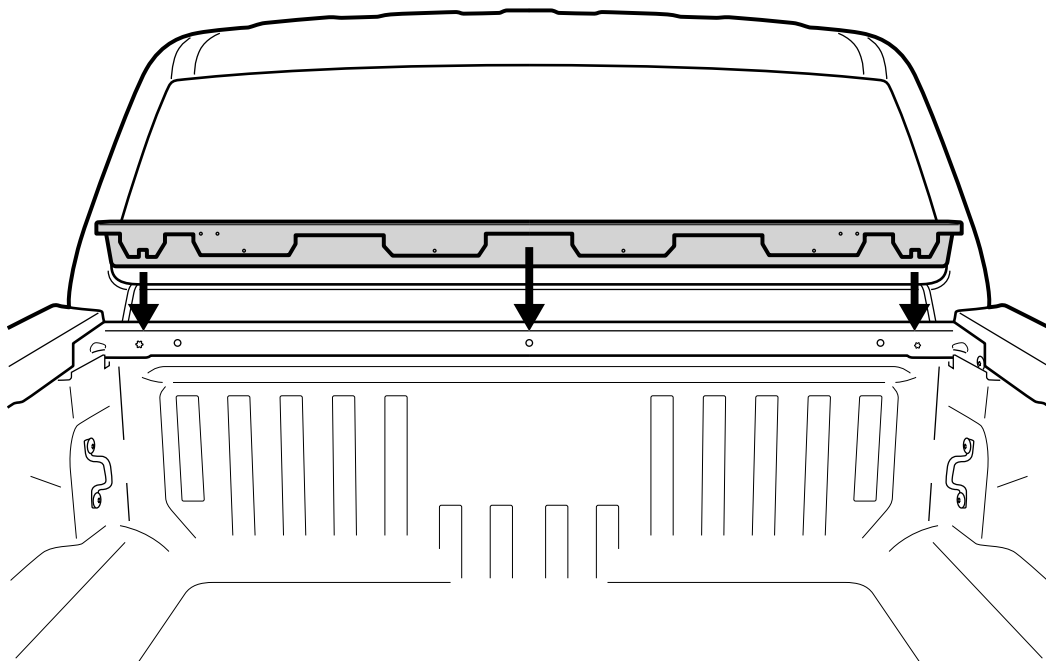

Center the front bar assembly  
(FR22-FBA).

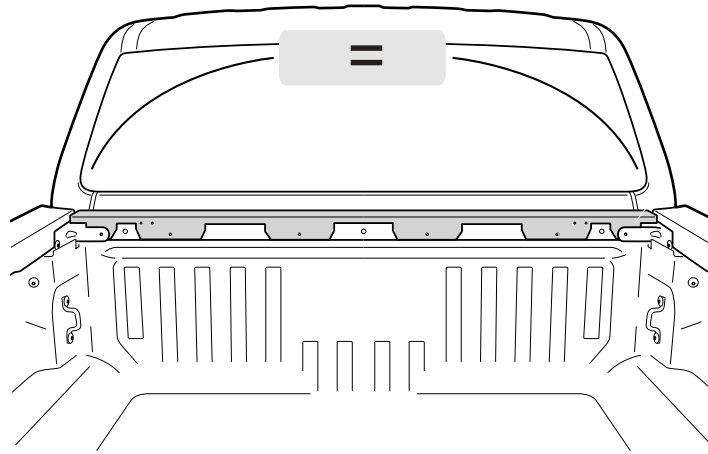

Align RHS brace bracket to the indicated threads of the tub.



If required trim top rail plastic cap to expose 2 factory threads.  
Repeat to the other side.

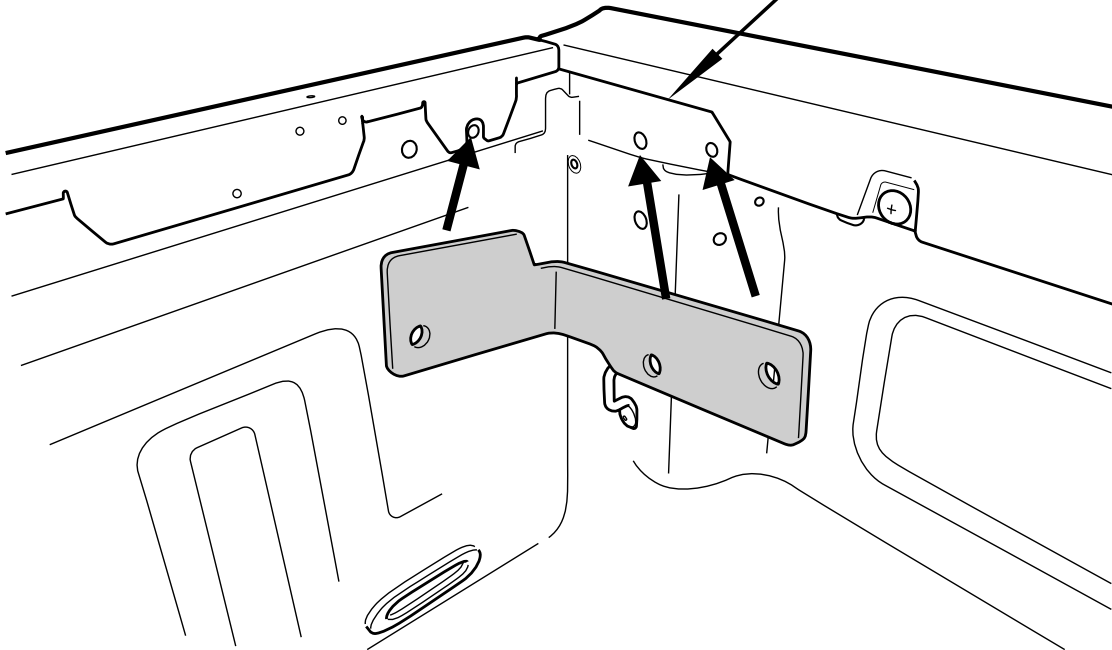

Fasten loosely into position using retained factory bolts.  
If factory bolts were not provided use supplied black M8 x 25mm in the kit.

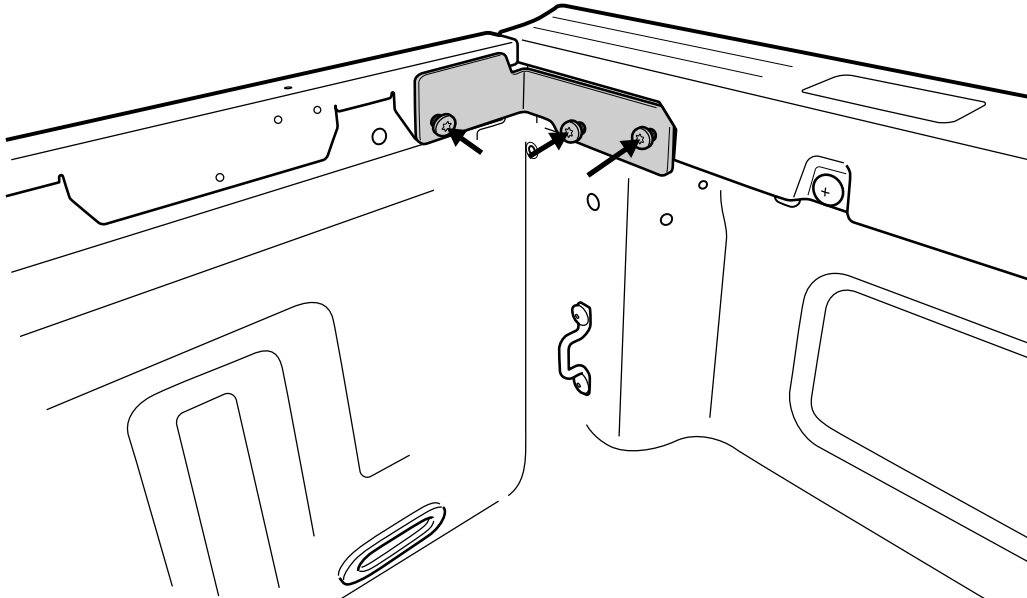

Repeat to the other side.

1. Fasten location **a**.
2. Fasten location **b**.

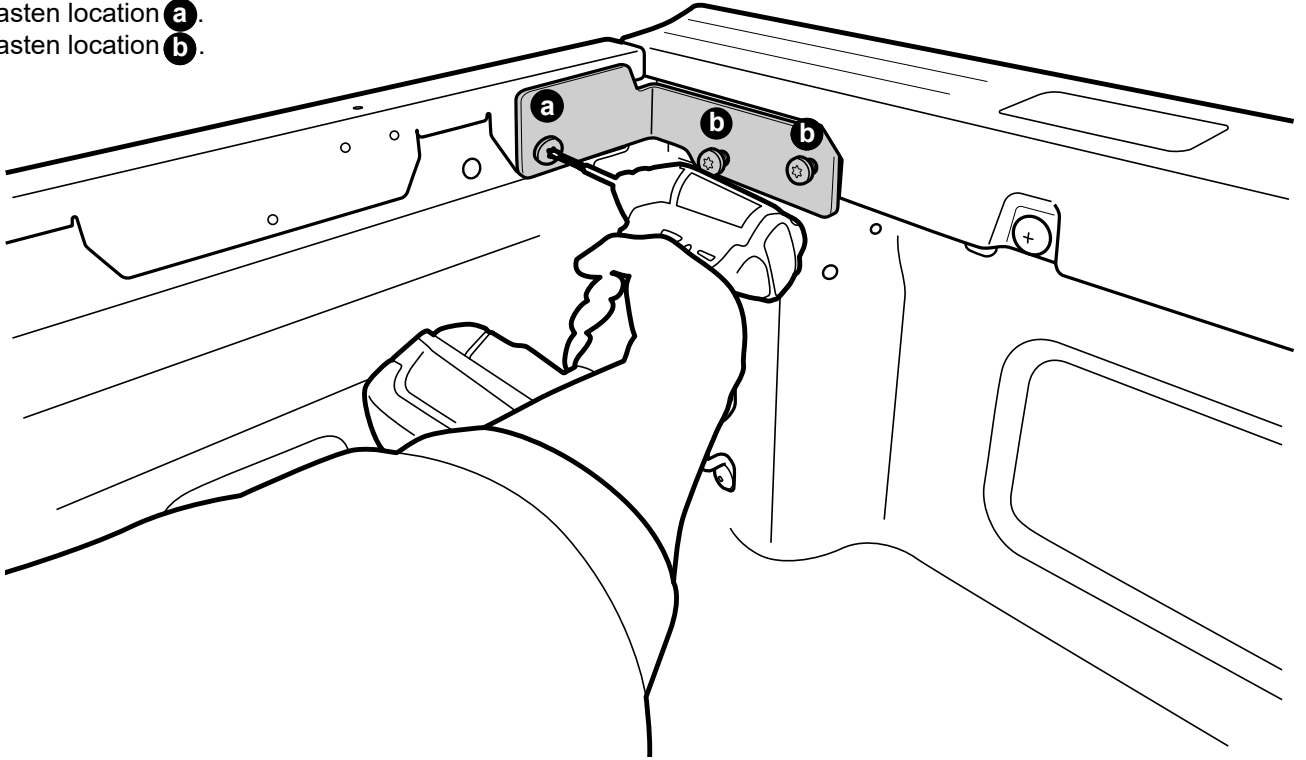

 Fasten FBA into position using supplied self drilling screw to indicated areas.

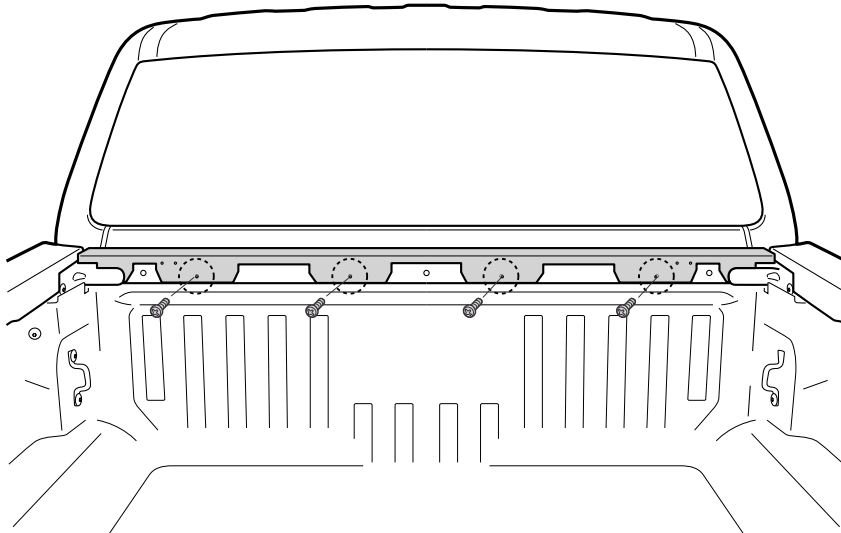

FBA and brace bracket assembled view.

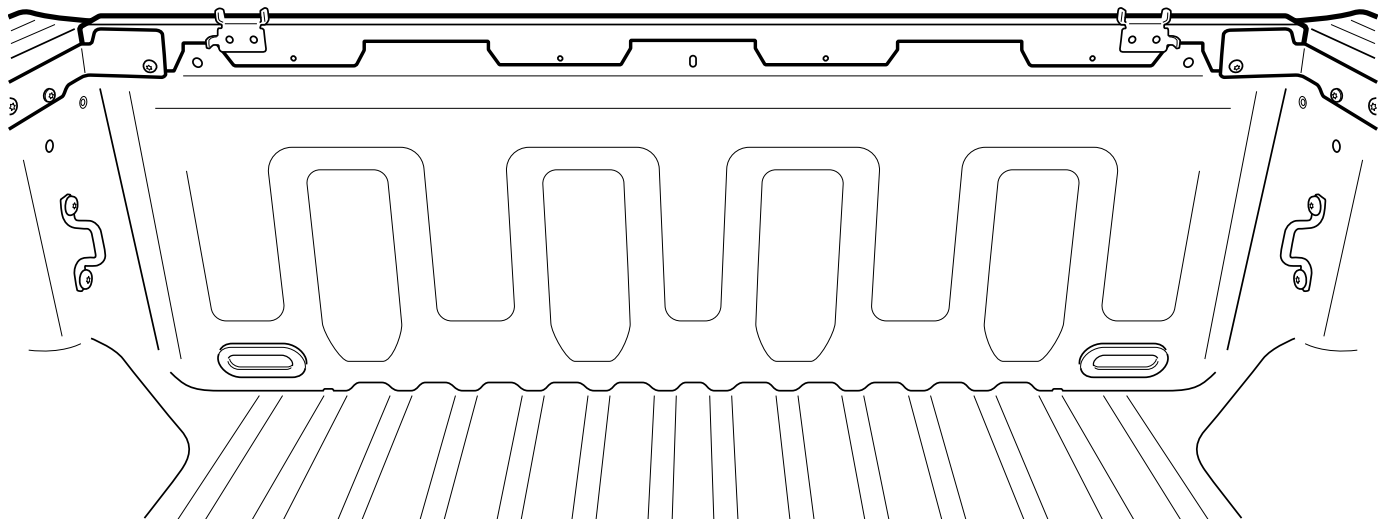

**Sealing any gaps on the bed and FBA. It is recommended to use black sealant.**

Apply an adequate amount of sealant to the areas indicated, then smooth sealant out.

Clean any excess sealant. Repeat to the other side.

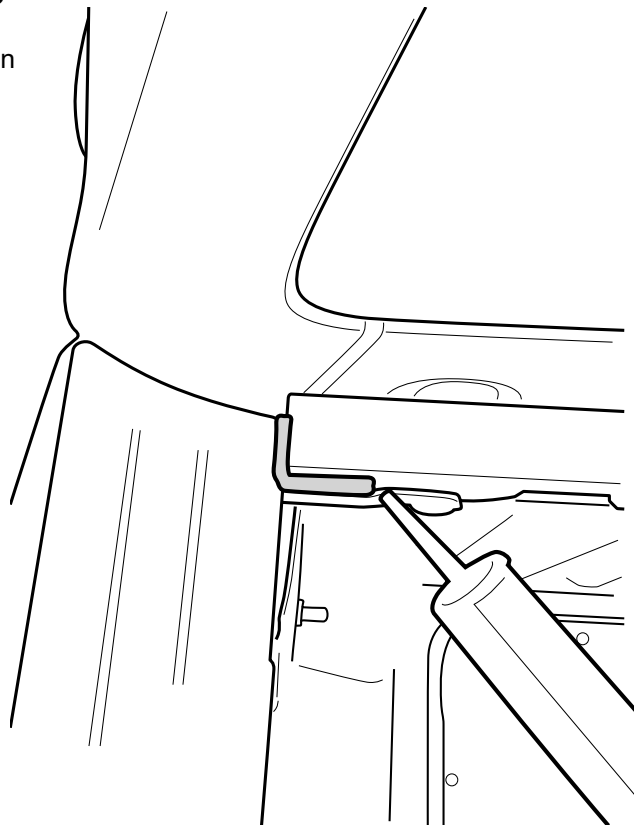

**Sealing any gaps on the bed and FBA. It is recommended to use black sealant.**

Apply an adequate amount of sealant to the areas indicated, then smooth sealant out.

Clean any excess sealant. Repeat to the other side.

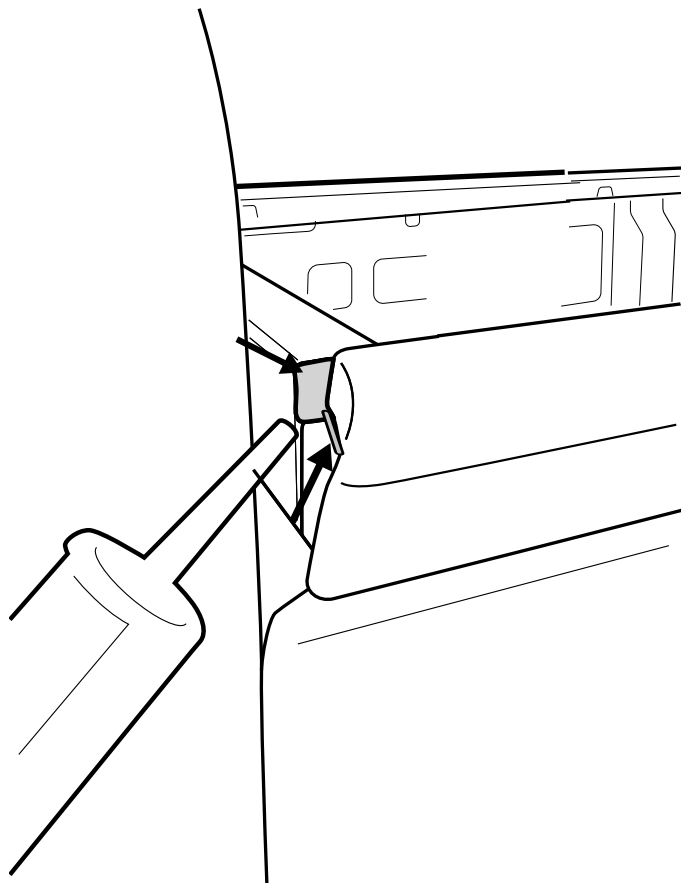

Remove indicated body clips.

Front of vehicle →

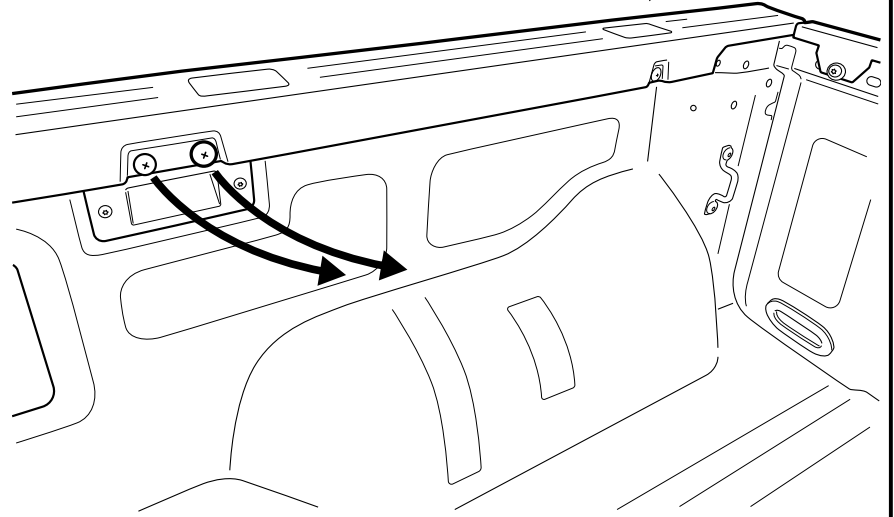

The diameter of the plastic and steel inner rail lip will need to be increased to 8mm,  
Using a 8mm drill bit, drill the indicated location. Clean surface & apply rust inhibitor.

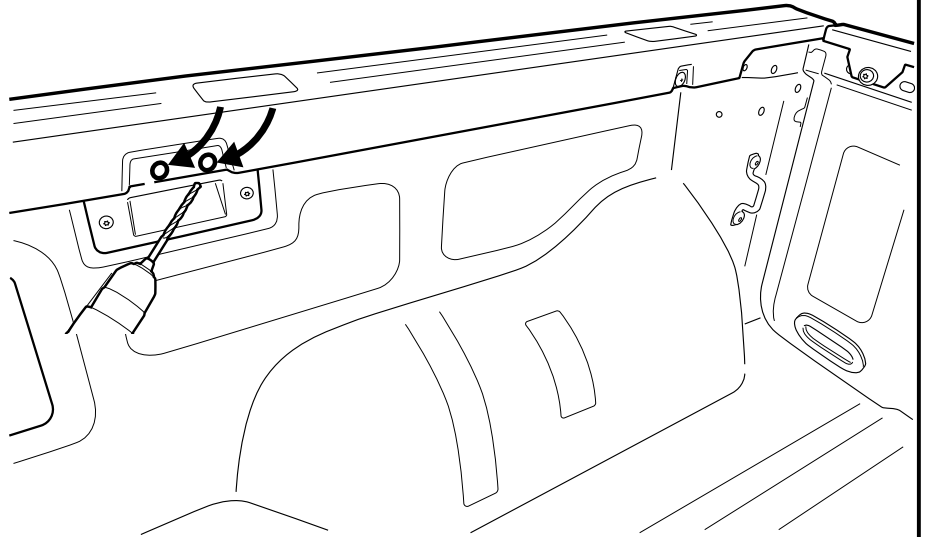

Feed part number (25) M8x25mm bolt through  
bracket 1048, and to the indicated location.  
**NOTE:** Follow orientation of bracket 1048 as per  
image.

Front of vehicle →

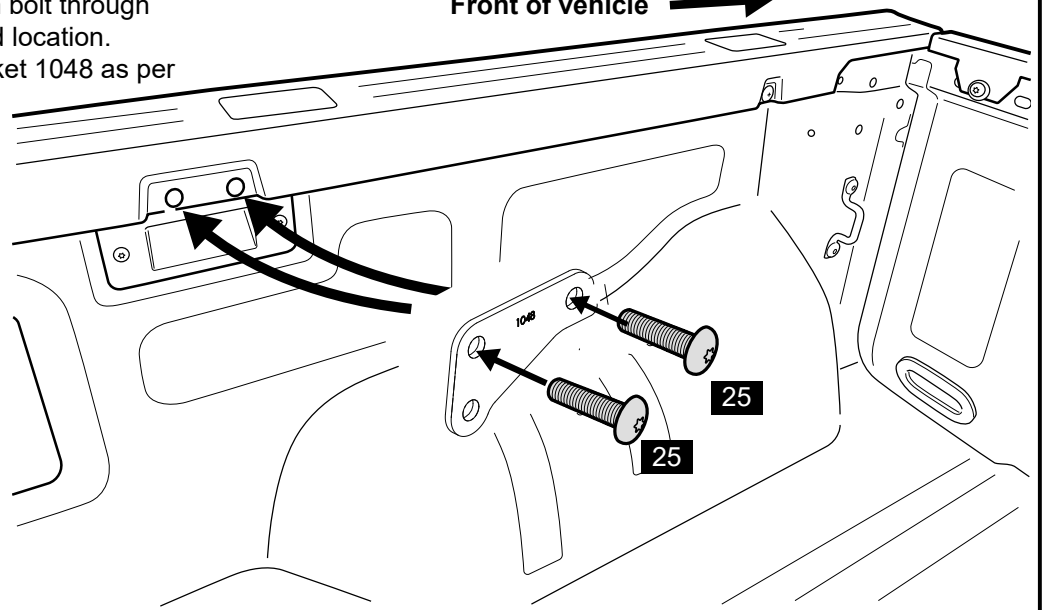

Fasten into position using supplied M8 3mm thick washer followed by M8 nyloc nut.

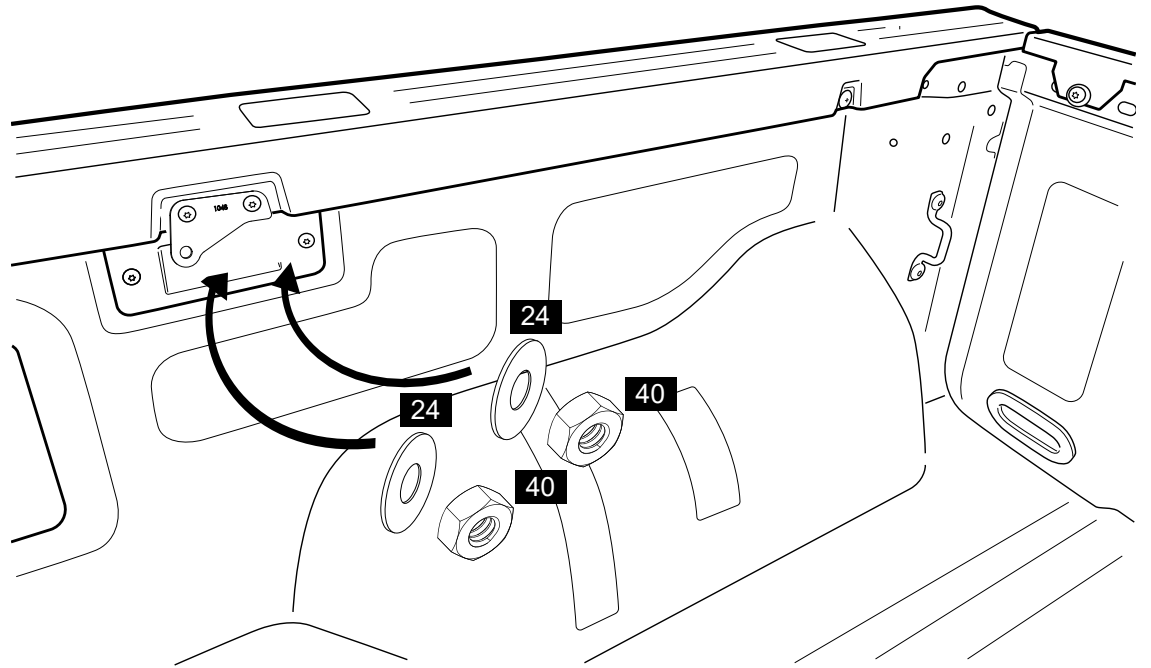

Feed part number (29) M8 stud ball to the indicated location.

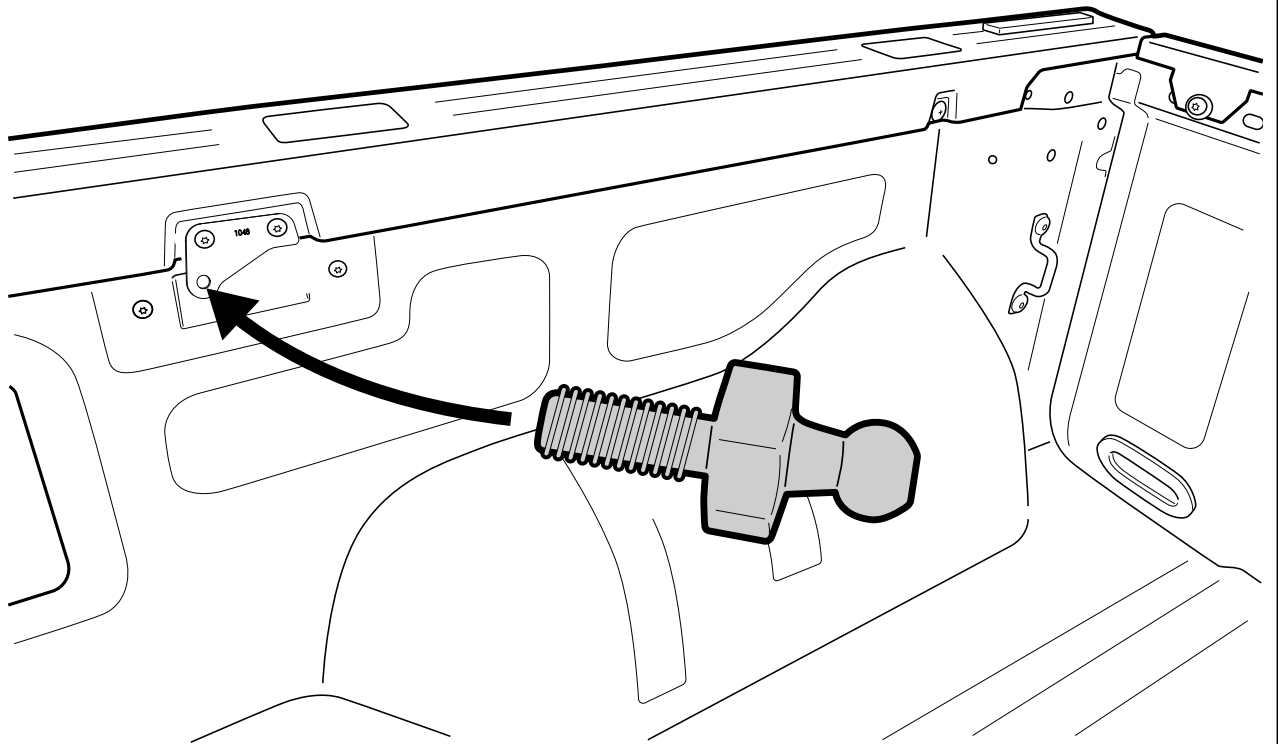



Fasten into position using supplied M8 nyloc nut.

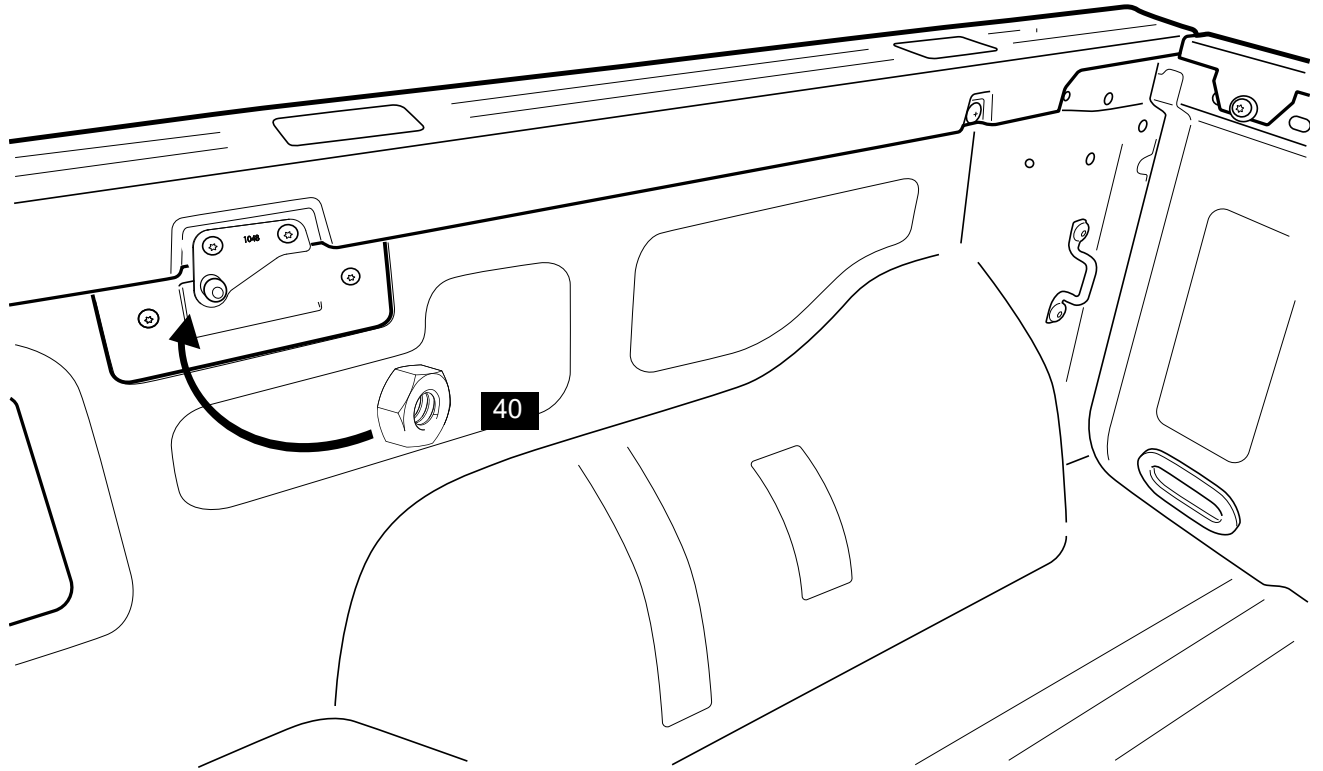

Click into position, shaft end of the strut to the stud ball.

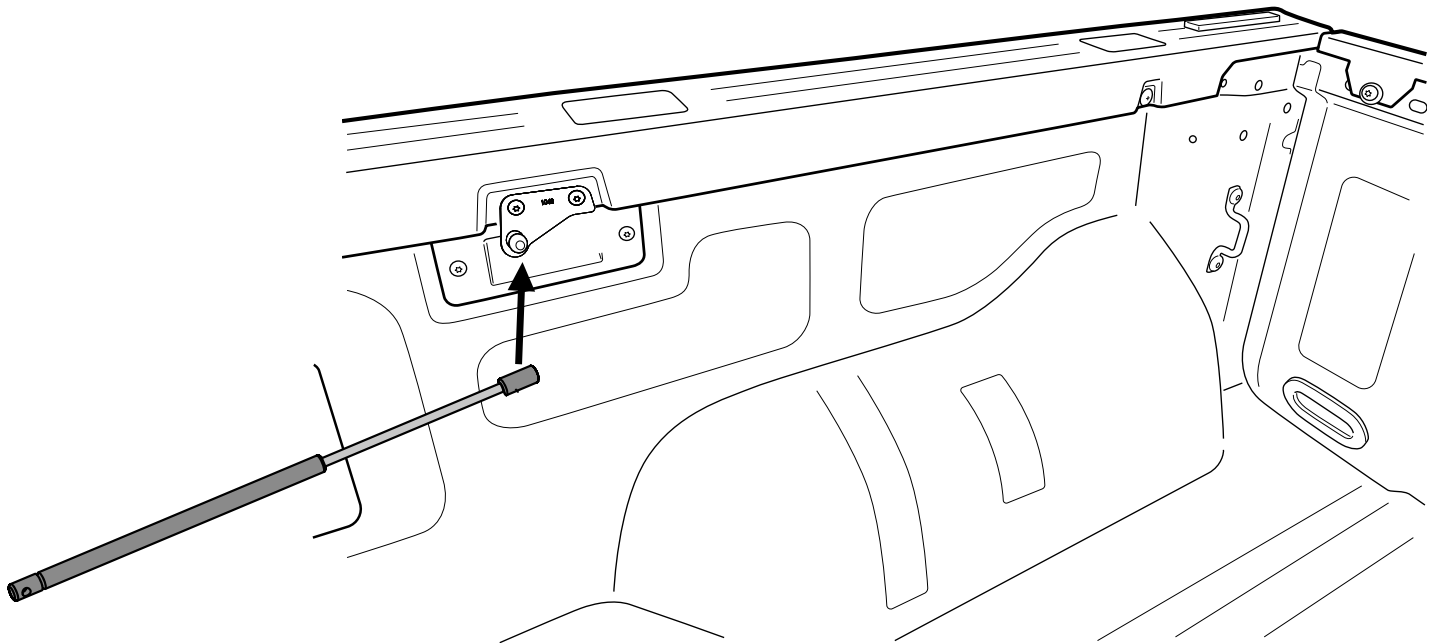

Remove indicated bolts and retain.

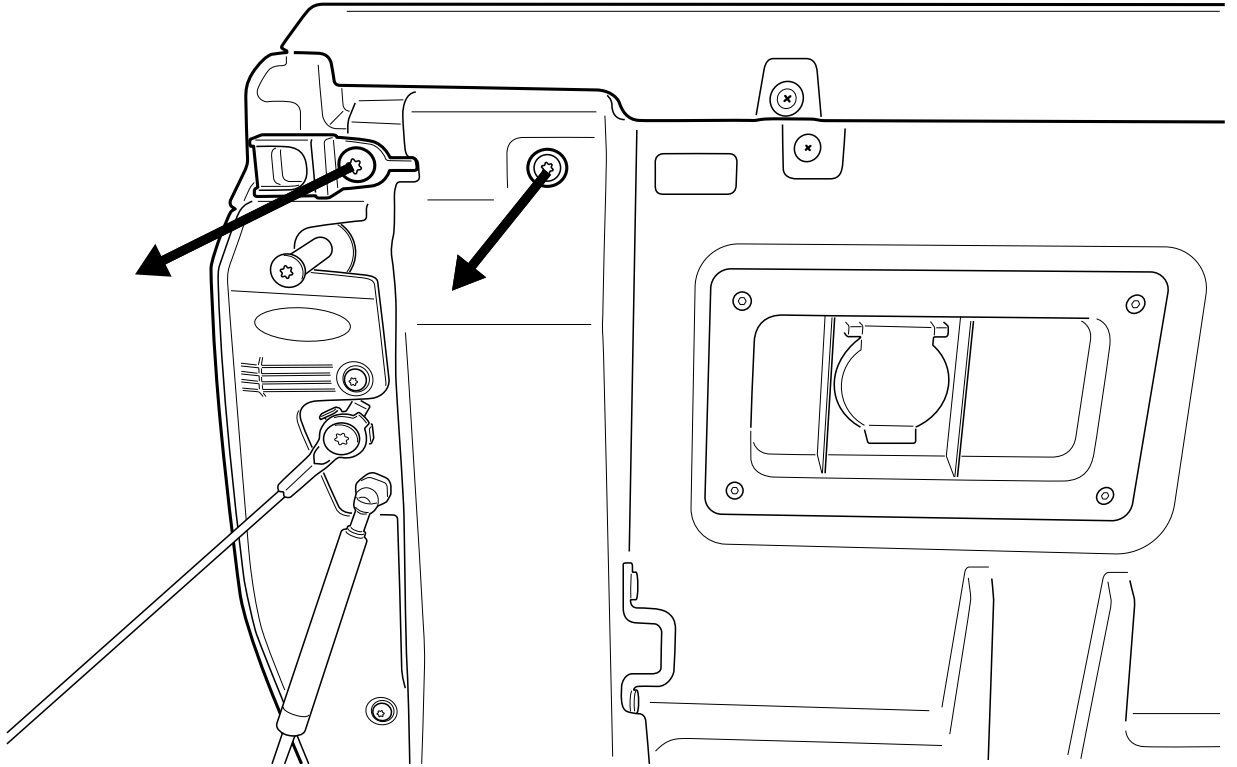

Align bracket 1189G-DS bottom holes with the tub indicated threads.

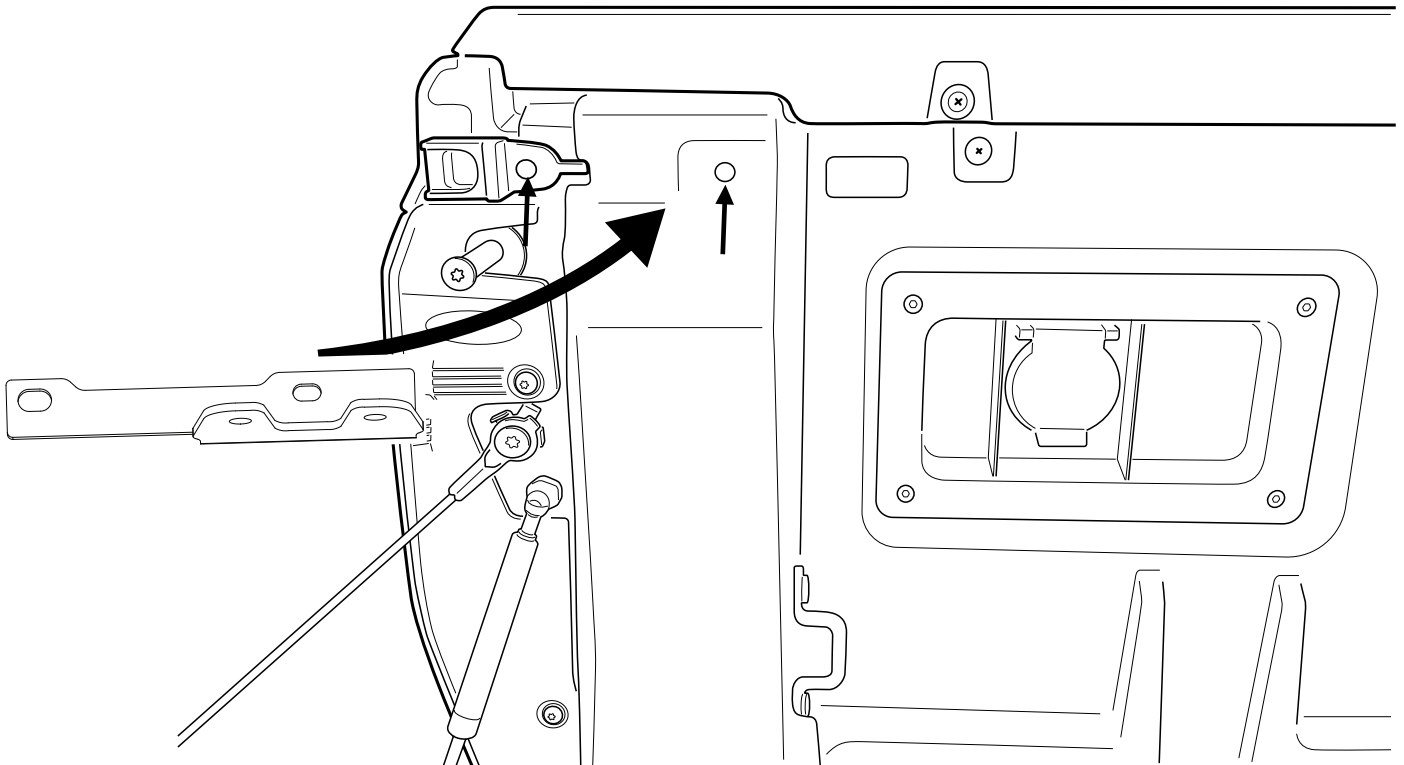

Fasten into position using factory retained bolts.

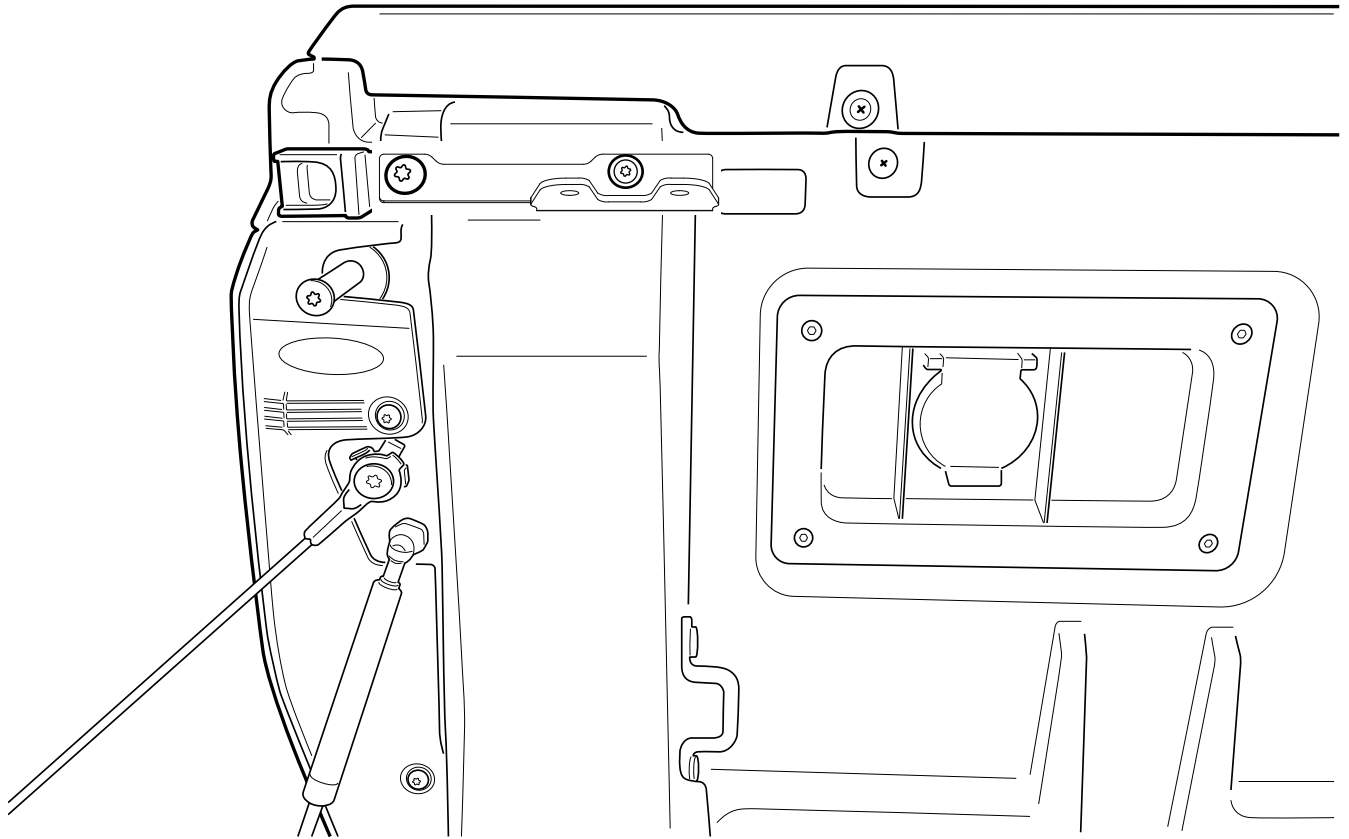

Attach lid hinges to tub hinges by aligning and pushing the pin through.  
Click pin down into hinge locking tab

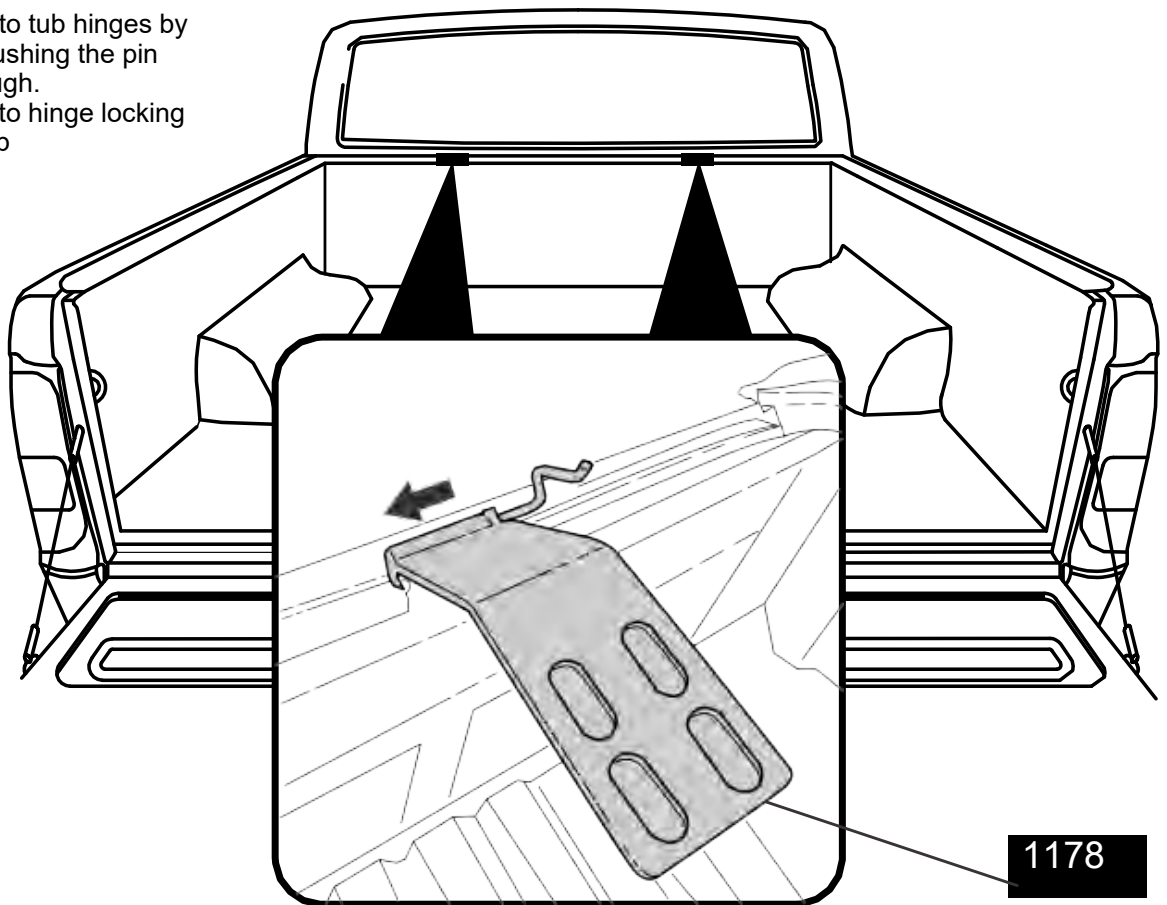

**Important:**  
Ensure tongues are fully inserted into the hinge slots with hinge pin securely in place.

Place lid on tub. From inside follow the assembly of hardware provided

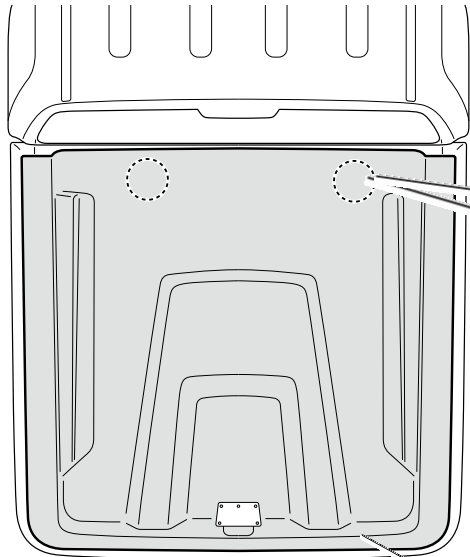

100

Bolts are to be fitted loosely to allow for adjustment in the next step.

ASSEMBLY ORDER

	100
	1018
	1178
	24
	M8 BOLT

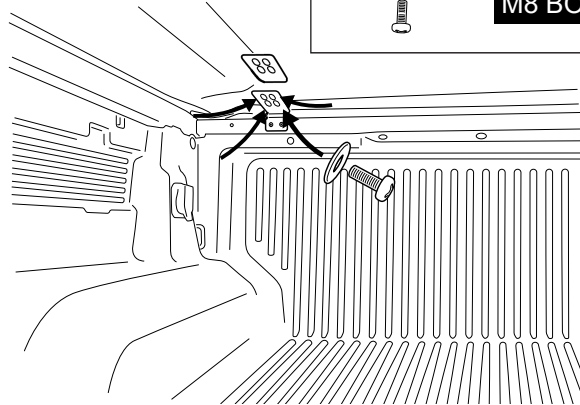

Adjust Lid so it is even on both sides and pull the lid back all the way so the front of the hinge bottoms out to the inside front lip of the lid.

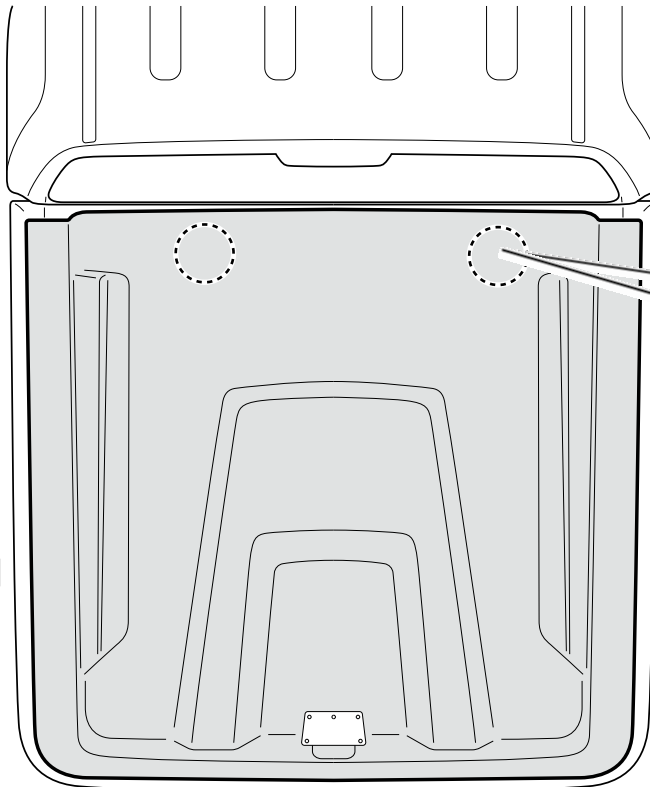

Note: Image showing lid in upside down position

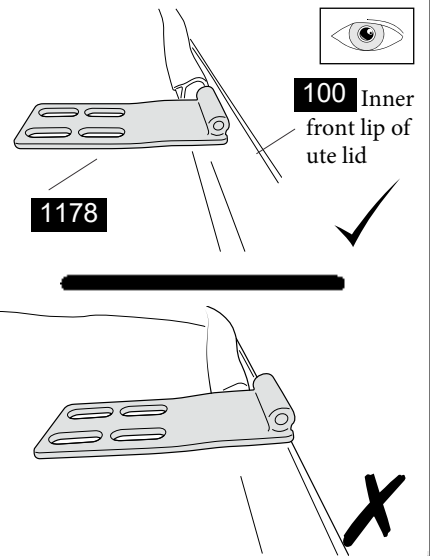

100 Inner front lip of ute lid

1178

⚠ Note: Pull lid back all the way so the front of the hinge bottoms out on the inside front of the lid.

With the lid in adjusted position, crawl into the tub and tighten all 8 bolts to 3nm torque

With the Hard Tonneau Cover opened, attach the cylinder end of each gas strut onto the mounting brackets attached to the Hard Tonneau Cover by clicking into place

Attach the gas struts between the lid and the mounting brackets.

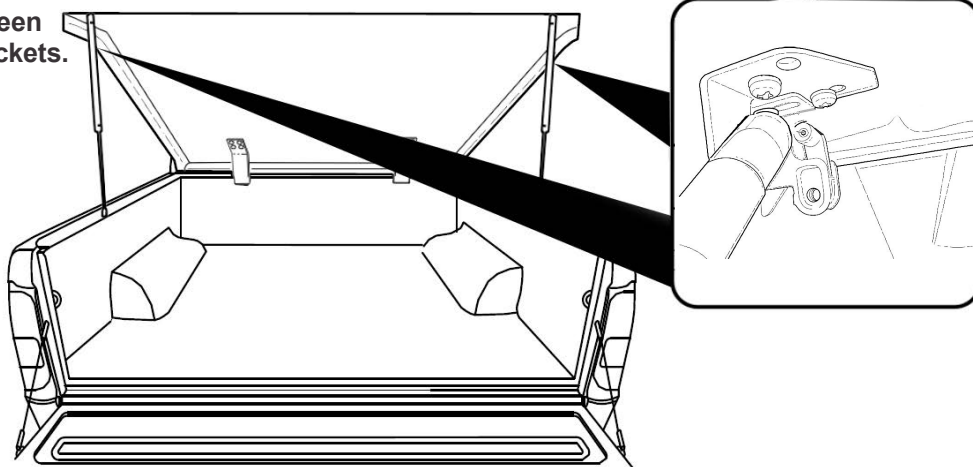

**Install Striker U bolt to 1189 bracket.**

Feed the m8 nut to each thread of the u bolt then through the striker bracket followed by the remaining m8 nuts.

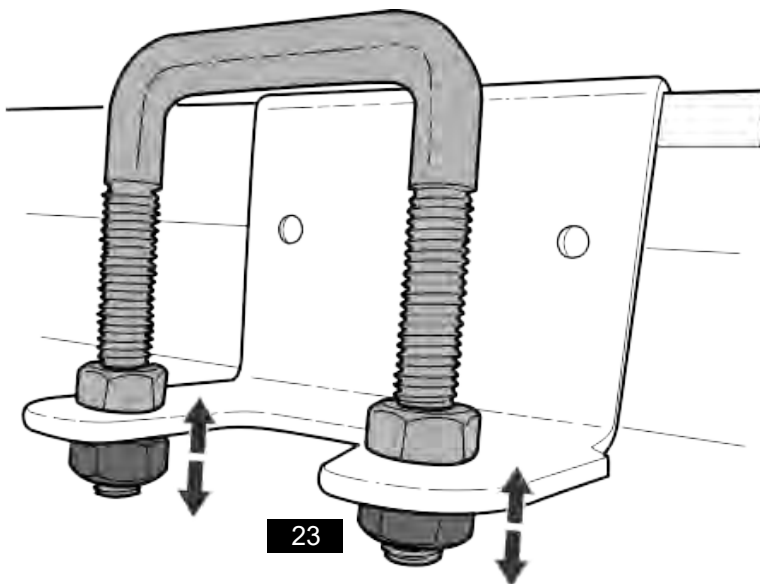

Loosen 2 screws and slide catch to align correctly with latch bar. Tighten screws to secure in place.

Adjust nuts on latch bar to alter height of bar to suit.

Repeat for the opposite side.

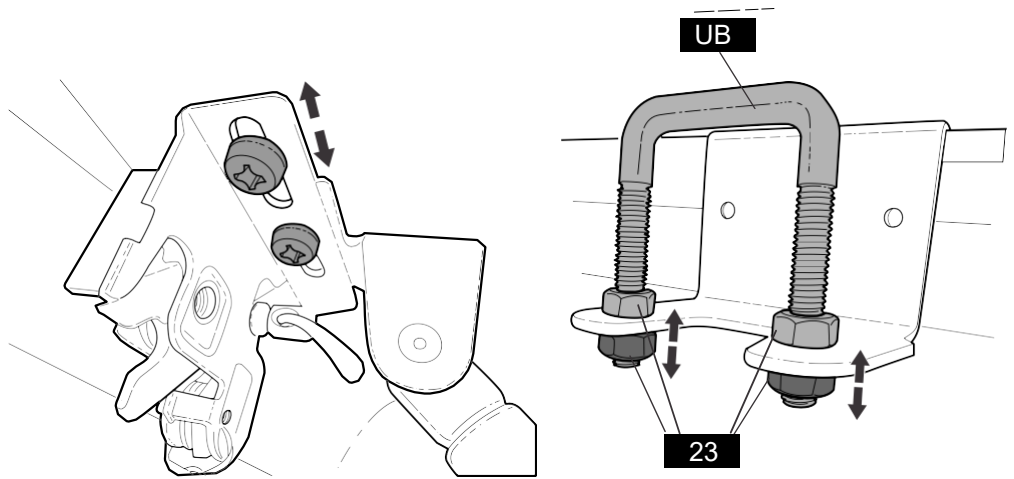

Use supplied Allen key to loosen the hex key screw on the catch and tension cable so it is tight but doesn't move the catch at all, then re-tighten the hex key screw.

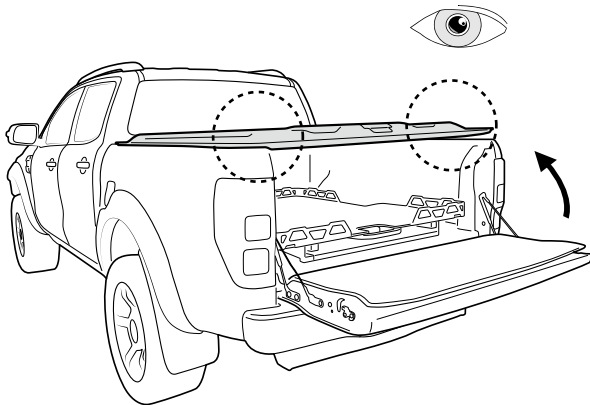
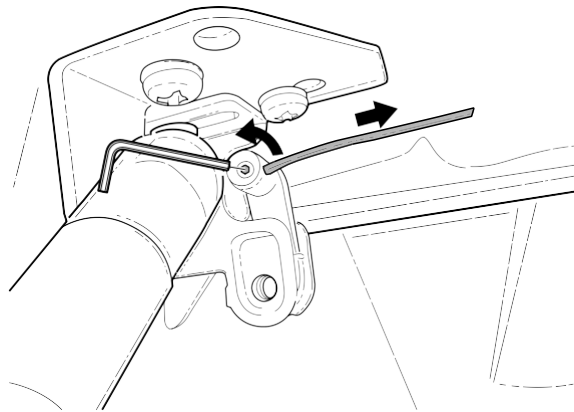

With the lid in closed position, lift the tailgate . The tailgate must close gently against the silverback lid's seal.

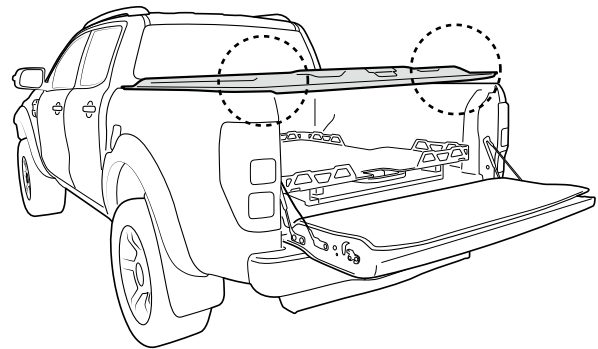

If you find the tailgate is hard to close, put the tailgate down and adjust the U bolt up until the desired closing of tailgate is achieved. NOTE: the seal must touch and compress gently to achieve sealing.

# HOW TO OPERATE YOUR SILVERBACK LID

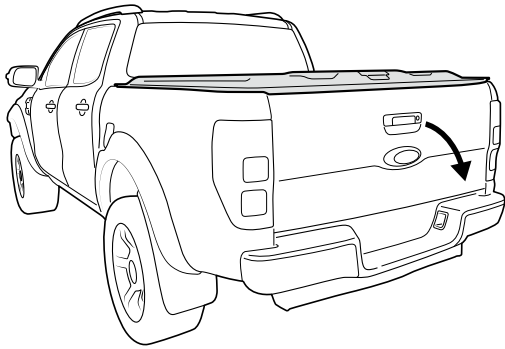

Open the tailgate

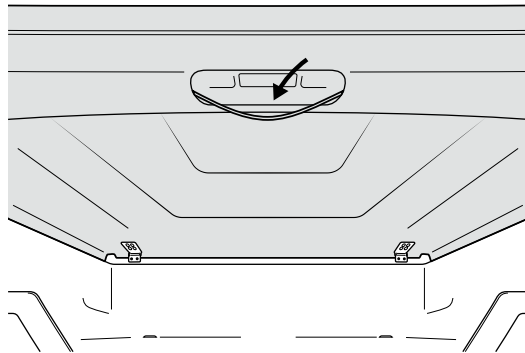
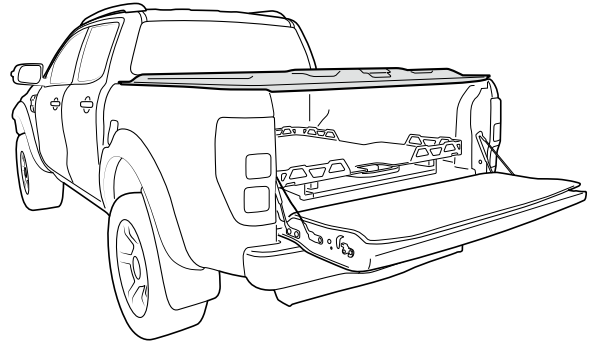

Now gently pull on the yellow release cable, so the rotary latch releases.

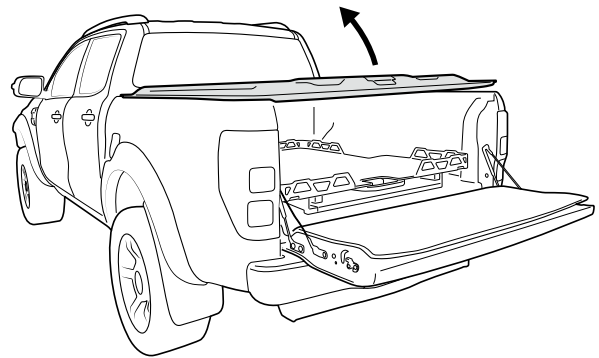

Aid the lid up, the gas springs will take over and it will lift it all the way.

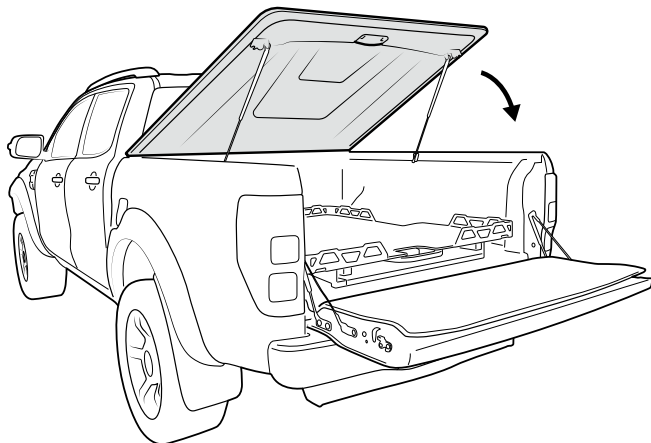

Close the lid.

Push each corner of the lid down so the rotary latch is engaged.

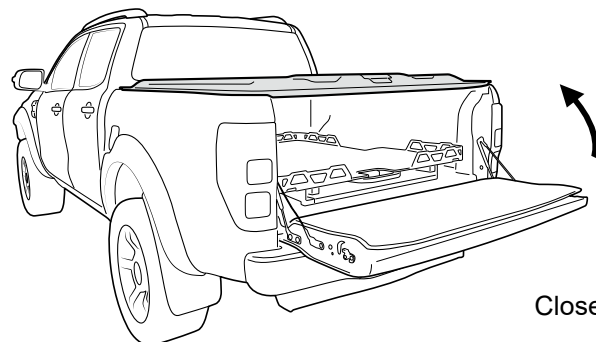
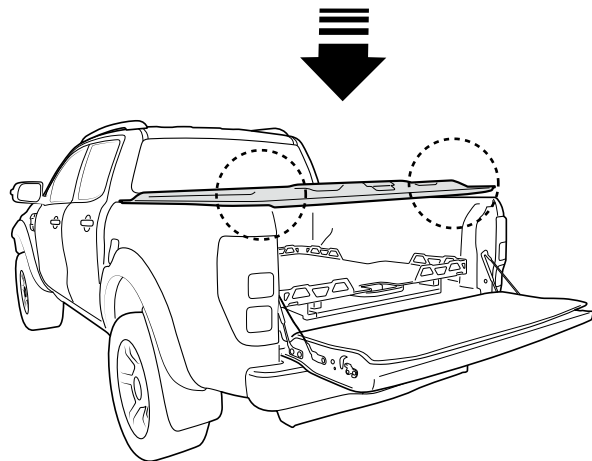

Close the tailgate

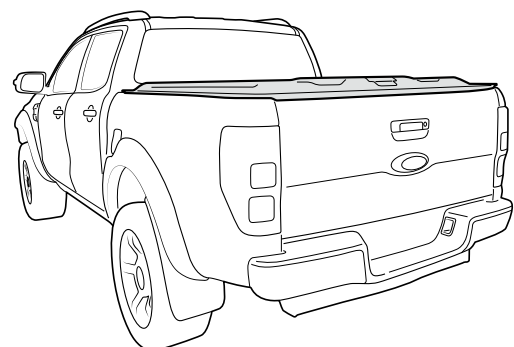

## REMOVAL OF TONNEAU COVER

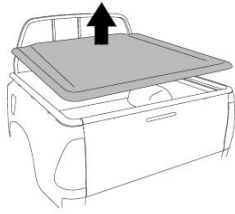

FIGURE 1

1. Open tonneau cover, Detach gas strut (1) by inserting a small screwdriver and adjusting the spring clip (2) on the gas strut (1). Refer to figure 2. NOTE: Do not remove the spring clip, only a small amount of levering is required to detach.

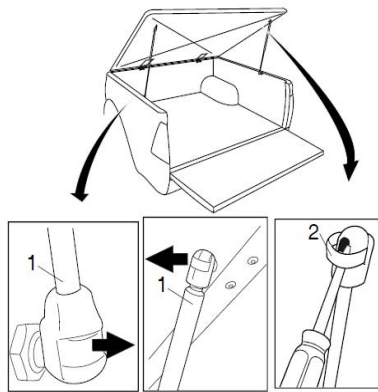

FIGURE 2

NOTE: 2 people are required to lift and remove the tonneau cover from the vehicle.

2. Remove hinge pins (1) and remove tonneau cover (2). Refer to figure 3.

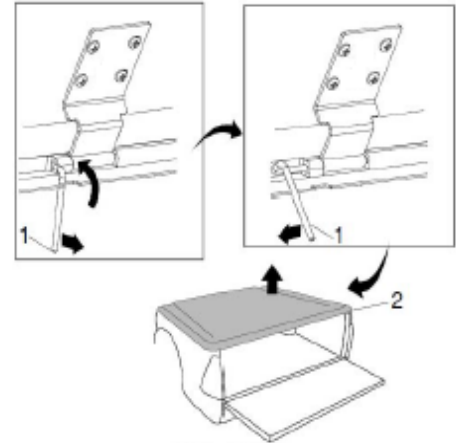

FIGURE 3

## REPLACEMENT OF TONNEAU COVER

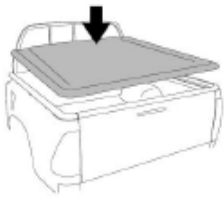

FIGURE 4

NOTE: 2 people are required to lift and fit the tonneau cover onto the vehicle.

1. Fit tonneau cover (2) and secure hinges with hinge pins (1). Refer to figure 5.

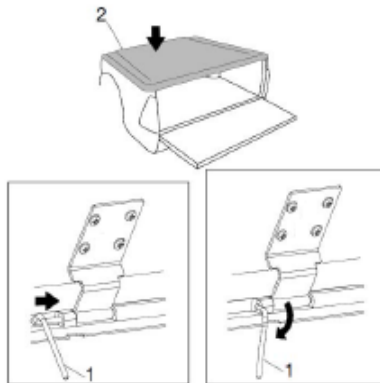

FIGURE 5

2. Attach gas struts (2) by clipping into place. Ensure narrow end (1) mounts to the vehicle. Refer to figure 6.

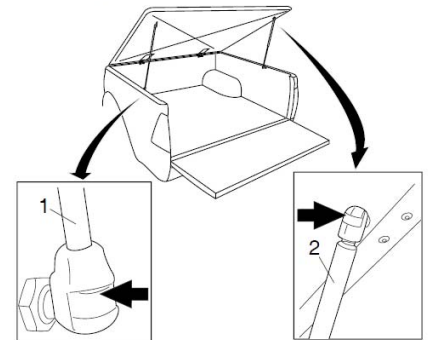

FIGURE 6

### Paint care instructions:

Your new painted Hard Tonneau Cover has been covered with a plastic film to protect the paint from damage. It will require cleaning and possibly light polishing after the protective film has been removed. Use polish as per new paint on a new vehicle. Wash Hard Tonneau Cover using water and normal carwash detergent and polish with an automotive polish.

**NOTE: Please ensure Lid is kept locked at all times when not being used, for both safety and longevity.**