



Important Information!

Please note that with the box of the Roll R Cover, there is a service kit that includes:

- A User Guide**
- Specific Lubrication**
- A Servicing Guide**
- A Warranty Guide**

This must be handed over to the end user in order for them to register their warranty and understand the servicing requirements.

ROLL. R. COVER[®]
SERIES 3



INSTALLATION INSTRUCTIONS

**Vehicle Model: VOLKSWAGEN
AMAROK NEW GENERATION 2023+
Fitted with Armour bar**



INSTALLATION TIME: 2 hours and 15 minutes (Approximately)

IMPORTANT	<ul style="list-style-type: none"> Do not stand/sit or rest heavy objects on Roll R Cover Humans or animals are not to be under the closed cover at any given time Tonneau Cover is not dust or water tight If contact with volatile chemicals occur, clean Cover with mild detergent and water solution Next Gen VOLKSWAGEN AMAROK Warranty Additional Information. <div style="text-align: center; margin: 10px 0;">  </div> <div style="margin-top: 10px;"> <p>If you are self installing: Please scan QR code to access important information.</p> <p>If you are fitting on behalf of someone: Advise them that they must scan QR code to access important information at hand over.</p> </div>
------------------	---

Care Instructions	<ul style="list-style-type: none"> Read Instructions fully before commencing installation. Clean Cover with a mild detergent and water solution Do not use abrasive cleaners or solvents Refer to manufactures instructions applicable to power drill. Protect Tub floor against scratches during installation process.
--------------------------	--

Maintenance	Refer to Maintenance instructions.
--------------------	------------------------------------

Tools Required	<ul style="list-style-type: none"> Pen / Marker Centre Punch Drill & Drill bits Caulking Gun Silicon - Non Acetic <ul style="list-style-type: none"> Scissors & Knife Spanner & Socket Tape measure Holesaw Filing tool <ul style="list-style-type: none"> Soapy water solution Allen Key set Screw driver Rust Inhibitor Trim Removal Tool
-----------------------	--



PERSONAL PROTECTIVE EQUIPMENT:

 Rubber Gloves





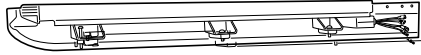
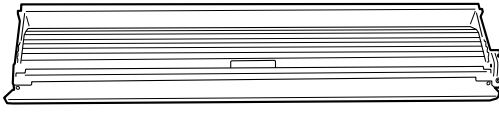





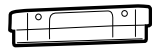
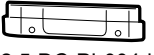

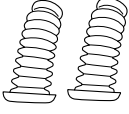

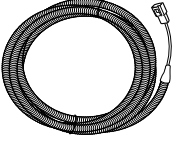
 Goggles

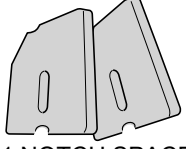
 Hearing Protection

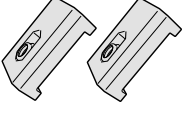
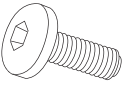
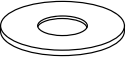

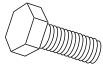

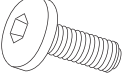
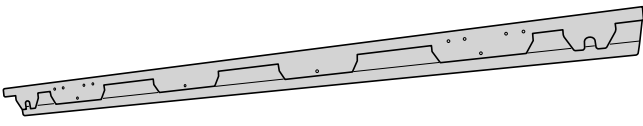
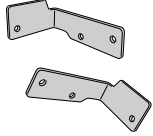
BOX CONTENTS

<p style="text-align: center;">LEFT & RIGHT SIDE RAIL</p> <p>S2.5-DC-AE-002ps-VA4a </p> <p>S2.5-DC-AE-003ds-VA4a </p>	<p style="text-align: center;">CANISTER ASSEMBLY</p>  <p style="text-align: center;">S3-DC-AF-VA-001/002</p>
<p>CANISTER TOP COVER  S2.5-DC-AE-005 -VA</p>	

VA4R SPECIFIC KIT

<p>COVER END CAPS</p>  <p>S2.5-DC-PI-004ps</p>  <p>S2.5-DC-PI-004ds</p>	 <p>COUNTERSUNK SCREW Qty - 4</p>	 <p>Drainage pipe Qty - 2</p>	 <p>BATTERY LOOM S2.75</p>	 <p>CABLE TIE Qty x 16</p>	
 <p>CL-LOOM-SHORT</p>	 <p>NGR-PATCH</p>	 <p>Self drilling screws Qty - 4</p>	 <p>1 NOTCH SPACER Qty - 4</p>	 <p>M8 NUT Qty - 4</p>	 <p>SIDERAIL CLAMP Qty - 4</p>
 <p>M8 x 45mm Qty - 4</p>	 <p>M8 WASHER Qty - 4</p>	 <p>M8 SPRING WASHER Qty - 4</p>	 <p>M6 x 25mm Hex head bolt Qty - 2</p>	 <p>M6 WASHER Qty - 2</p>	 <p>M6 SPRING WASHER Qty - 2</p>
 <p>BLACK M8 x 30mm Qty - 6</p>	 <p>FR22-FBA QTY - 1</p>		 <p>LEFT & RIGHT BRACE BRACKET</p>		

SPECIFIC KIT NGR-AB1

 <p>1/2 Inch washer WASHER Qty - 4</p>	 <p>M8 x 40mm COUNTERSUNK ALLEN Head Bolt Qty - 4</p>	 <p>3M PRIMER</p>	 <p>SIDERAIL HOLE GASKET Qty - 4</p>		
--	---	---	---	--	--

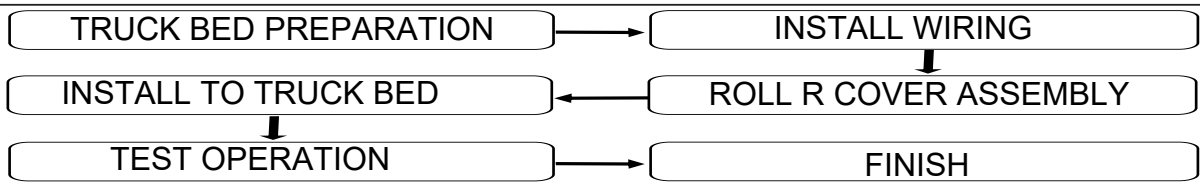

TUB PREPARATION

NOTE: Instructions may refer to one side of vehicle, repeat steps to the other side.

If the Vehicle is fitted with a headboard bar, remove from Ute Tub (truck bed).
Note: Retain hardware.

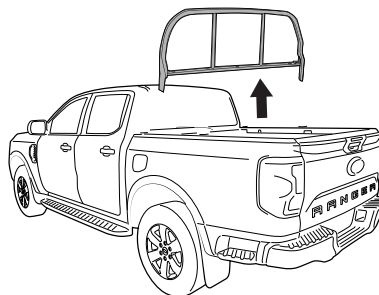

NOTE: Following steps are for vehicles fitted with a factory tailgate liner. If no tailgate liner skip to page 5.

Remove and retain indicated screws.

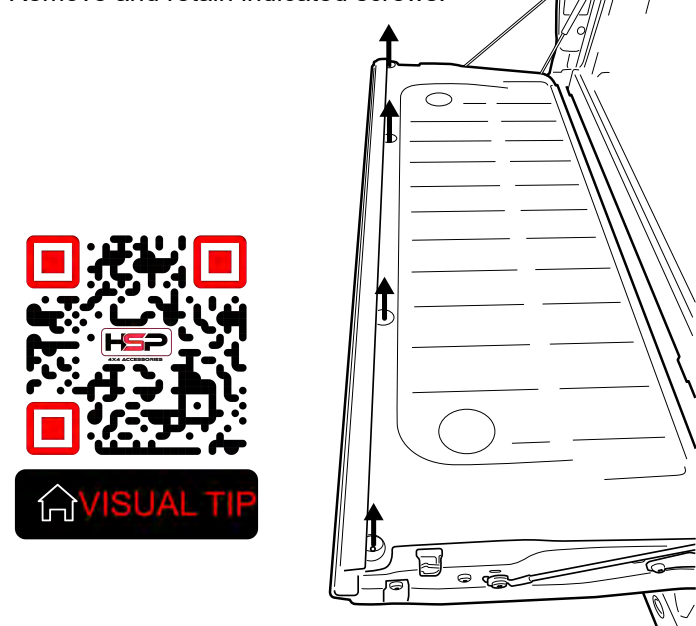

Push the tailgate's top plastic trim to expose the inner measuring guide of the trim.

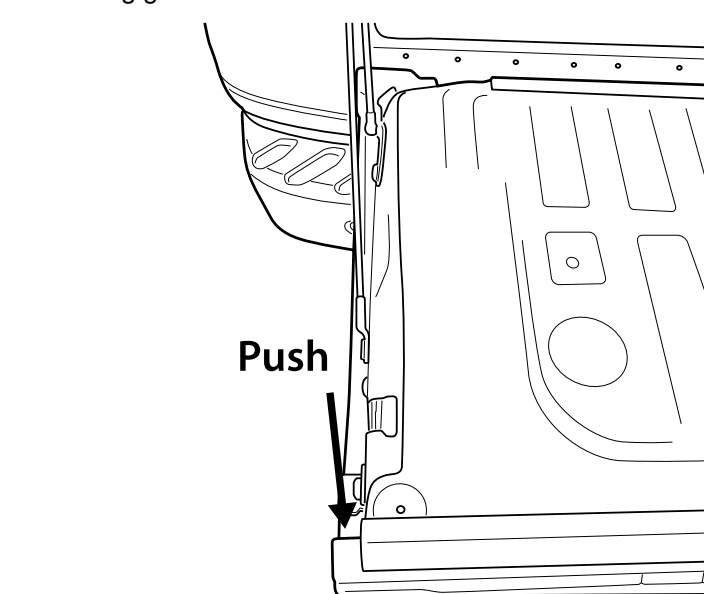

Using a plastic trim removal tool, carefully tuck the rubber molding in to the cavity behind the measuring guide.

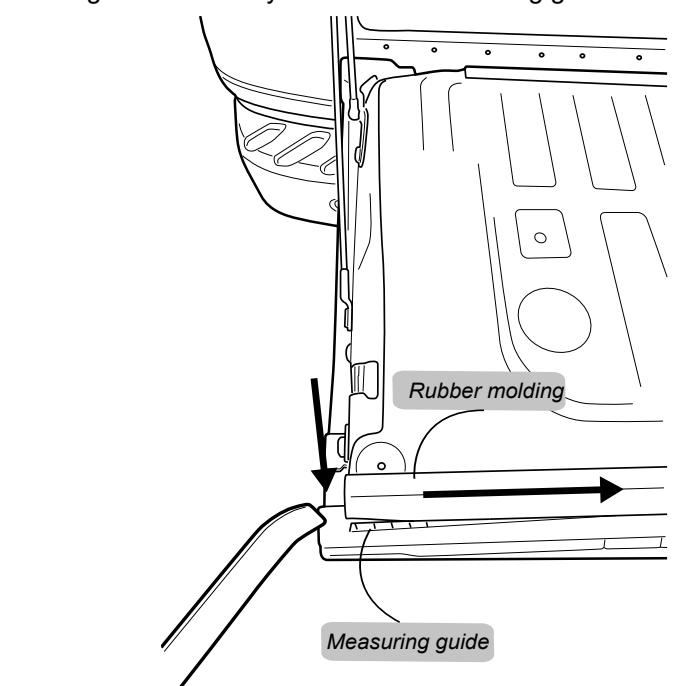

Slide plastic trim tool between cavity and rubber molding towards the other side.

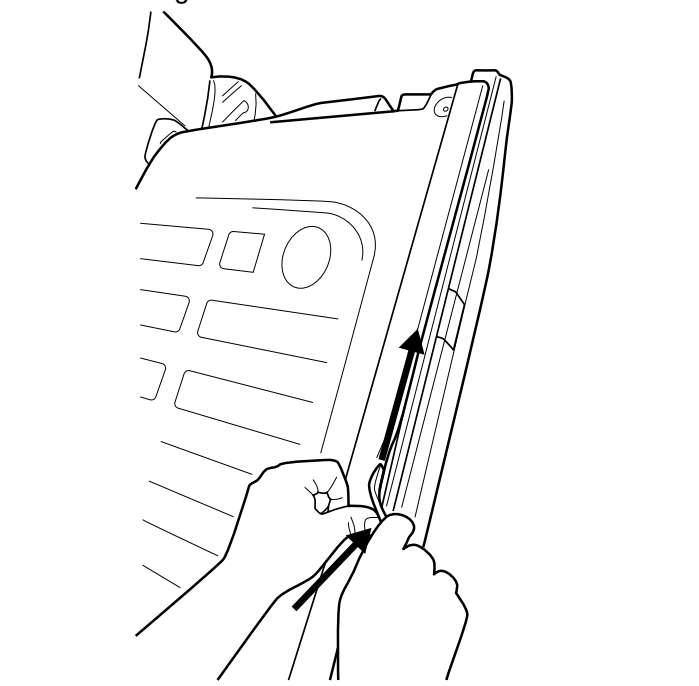

Using retained screws, fasten the tailgate liner in to position.

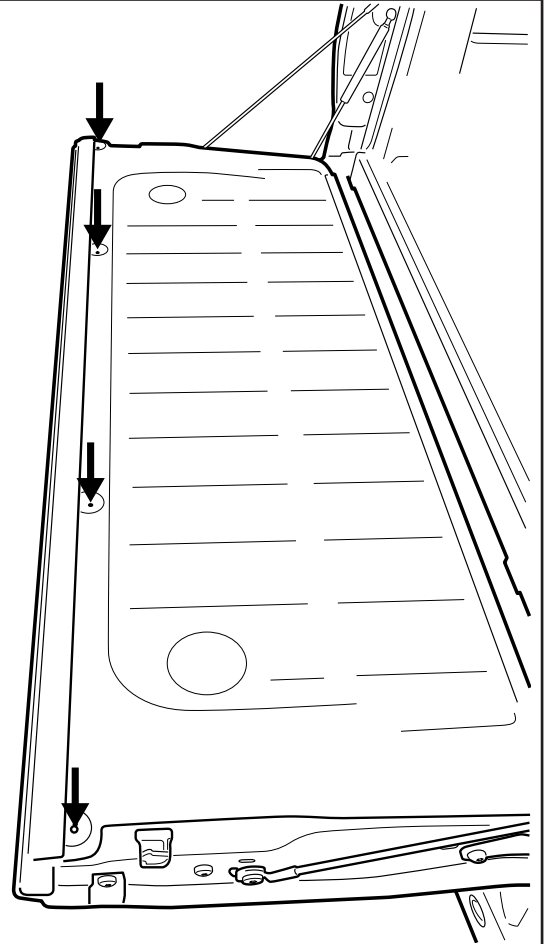

Completed view showing tailgate liners rubber moulding behind the measuring guide.

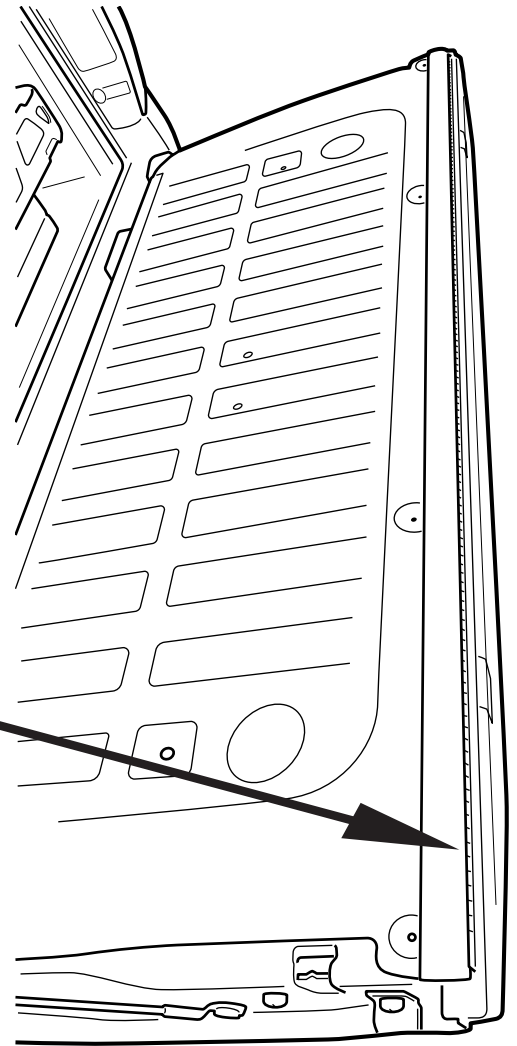
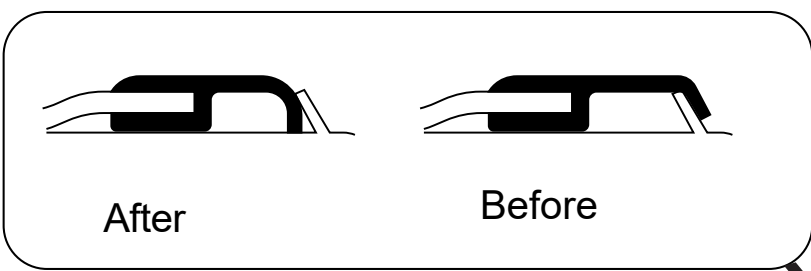

TUB PREPARATION

NOTE: Instructions may refer to one side of vehicle, repeat steps to the other side.

Measure down from top of headboard 180mm & 70mm measuring from the side of the top rail. Repeat to the other side.
Using a 50mm hole-saw drill the liner only as indicated.
NOTE: Only drill the tub liner at this step.

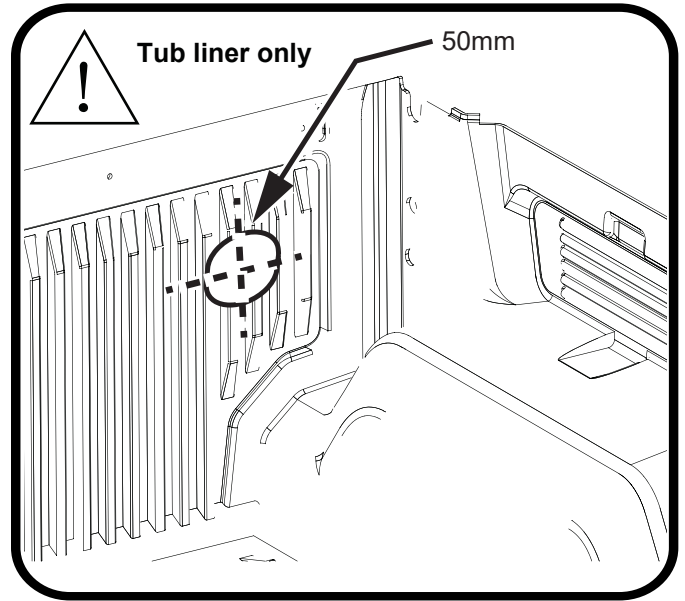
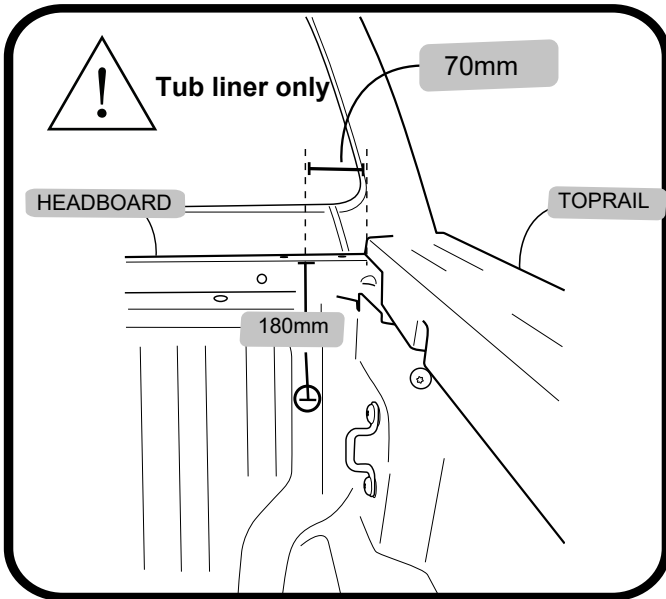
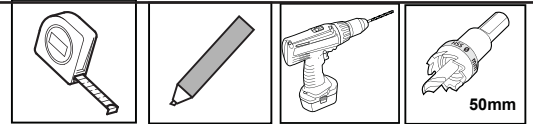

Now measure down from top of headboard 180mm & 70mm measuring from the side of the top rail. Repeat to the other side.
Now using a 30mm hole-saw drill through tub front panel, file away any sharp edges. Apply anti rust coating. Repeat to other side.

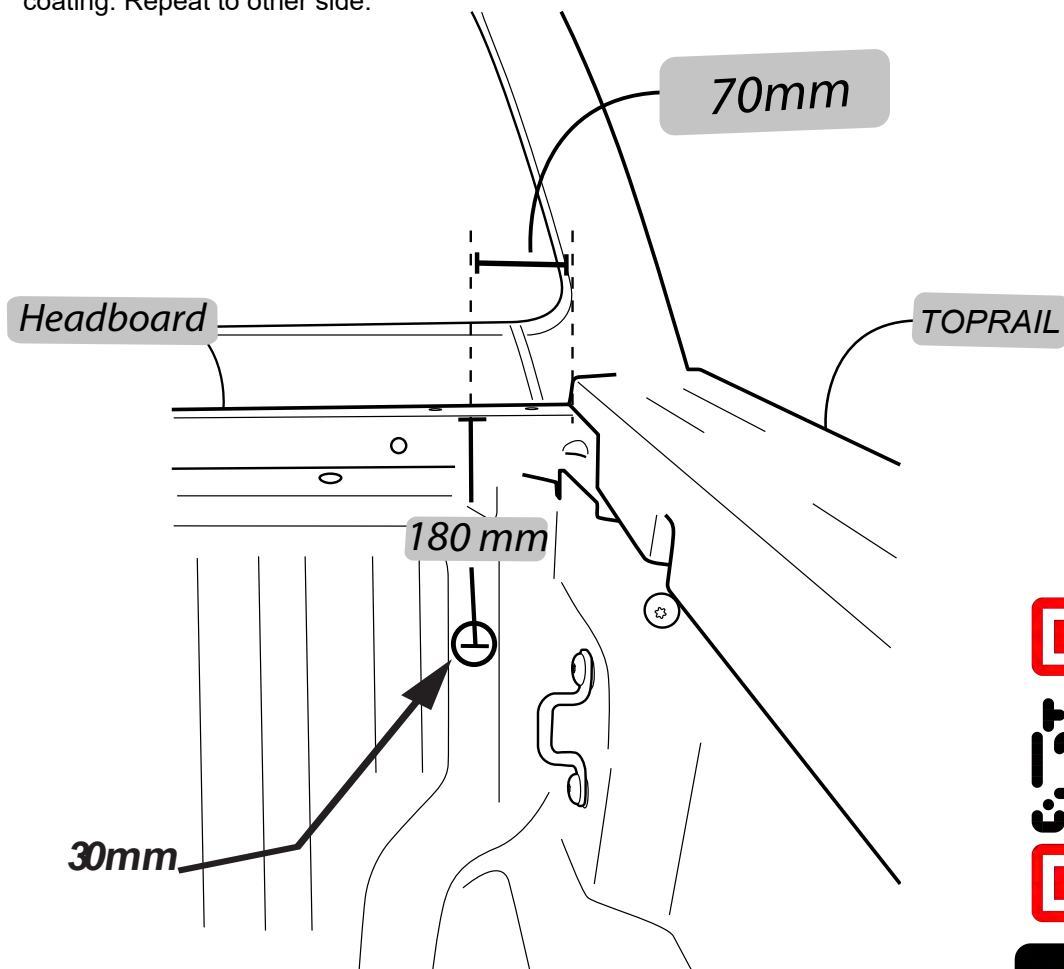
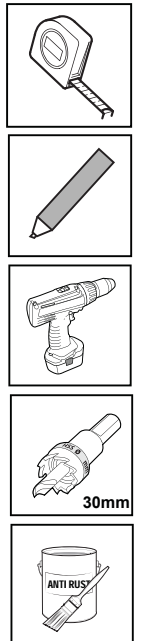

! ATTENTION: Do not exceed 30mm hole.

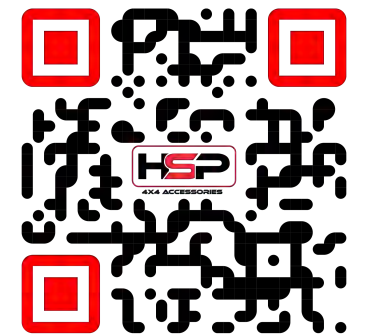

! VISUAL TIP

Carefully unpack the box.

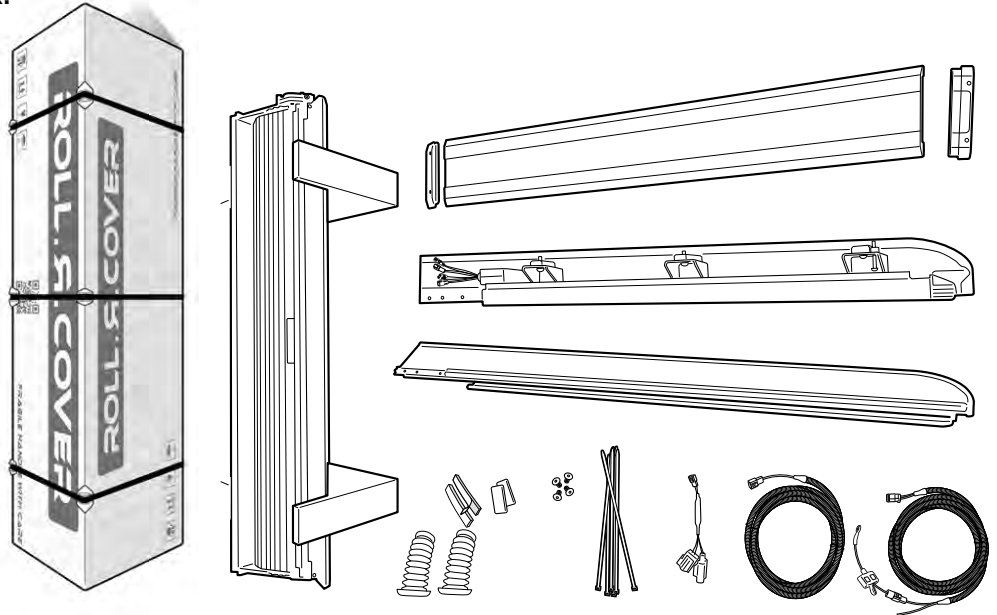

Install front drain pipes (55mm diameter end of hose) through drilled holes on the front tub panel.



Note: With care push tube in. Taking care pull the tube back so it seals correctly against the front panel of the tub.

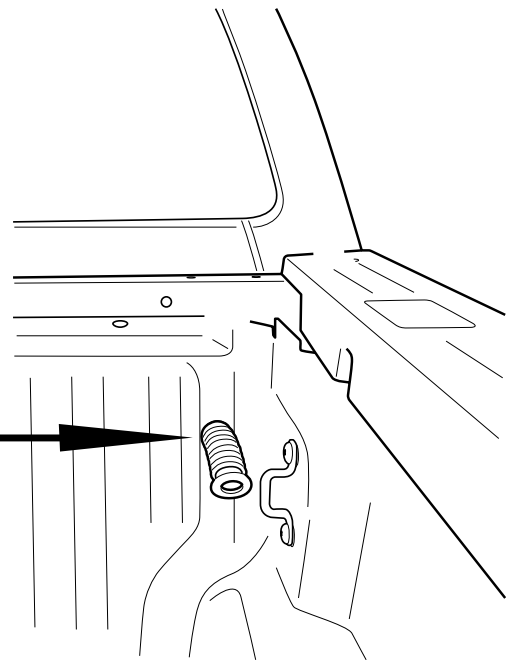
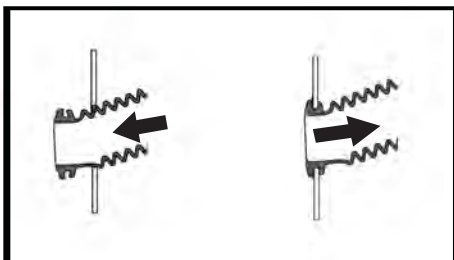

Measure down from top edge of the tub liner 55mm down, Now measure 70mm in towards the tailgate as indicated. Mark line as a guide, now trim that section of the tub liner and discard. Repeat to the other side.

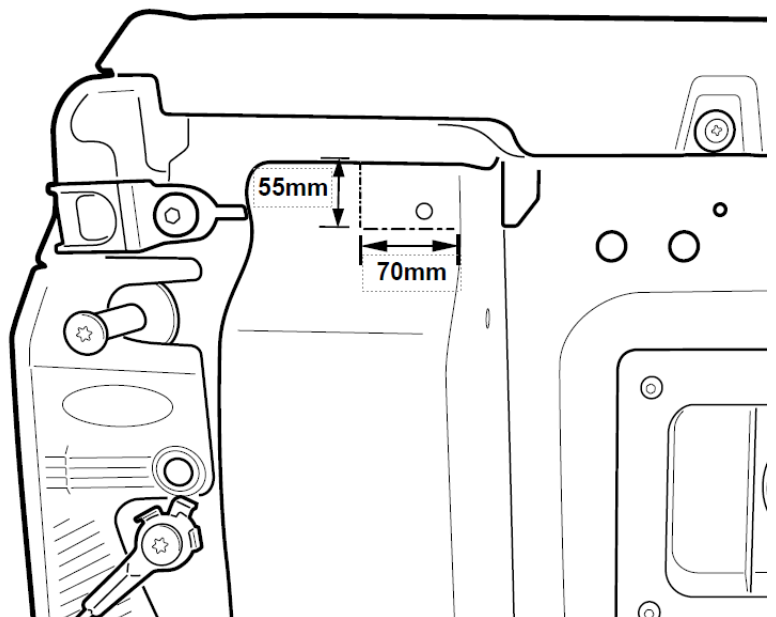

This step applies to vehicles equipped with a factory tub liner.

View with tub liner section trimmed.

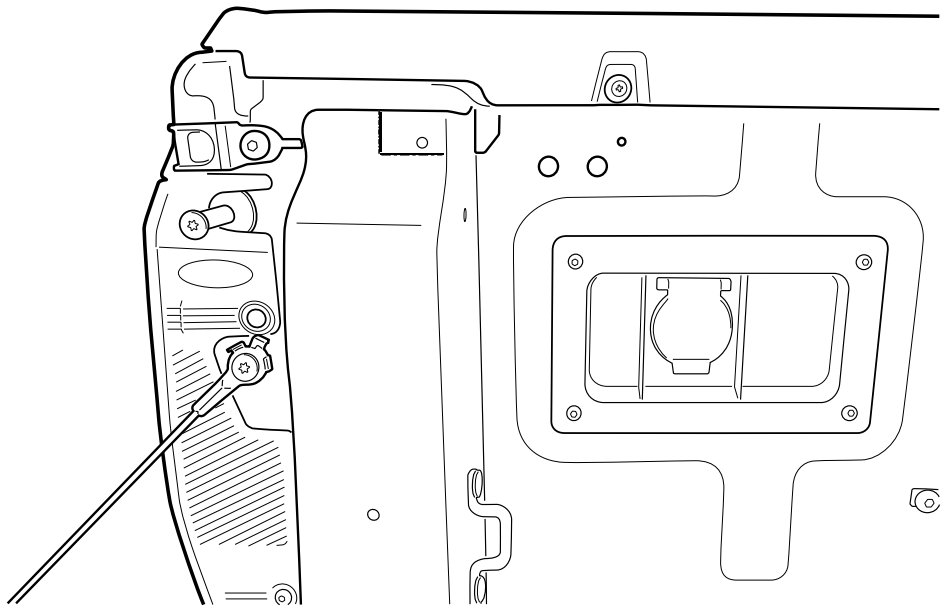

Sealing factory gaps on the bed. It is recommended to use black sealant.

Apply an adequate amount of sealant to the areas indicated, then smooth sealant out. Clean any excess sealant. Repeat to the other side.

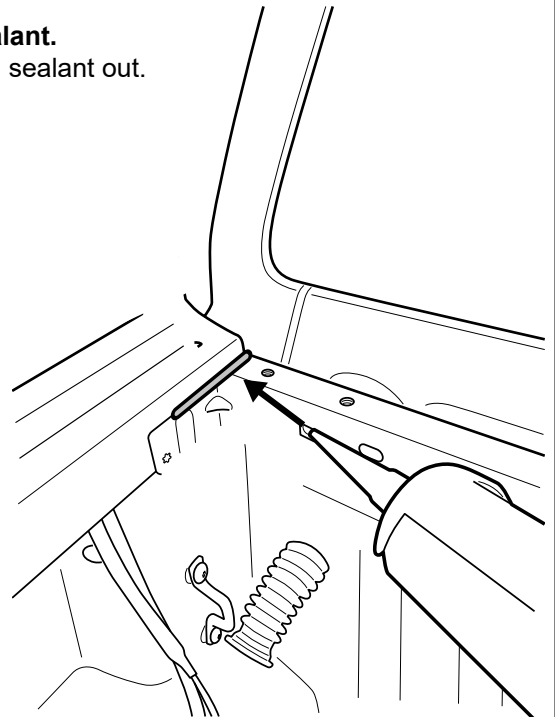
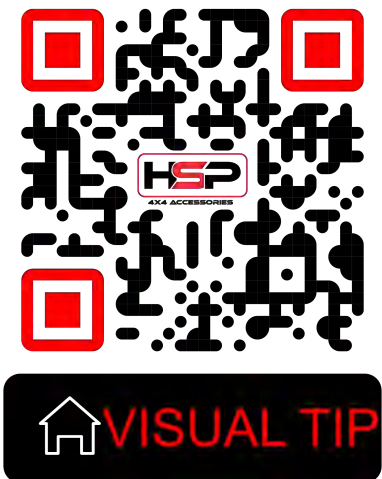

Place front bar assembly (FR22-FBA) over the head board.

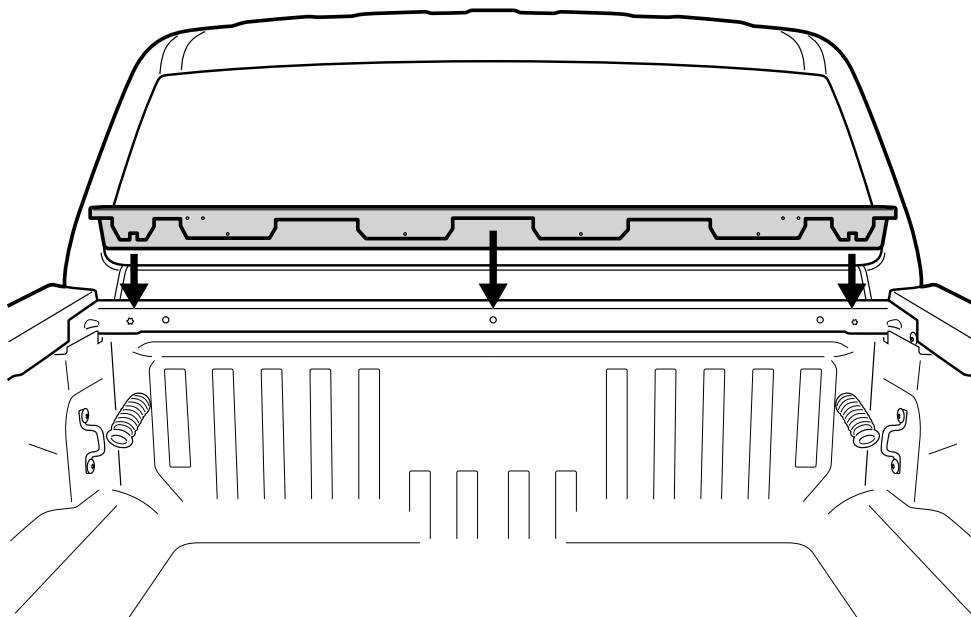

Center the front bar assembly
(FR22-FBA).

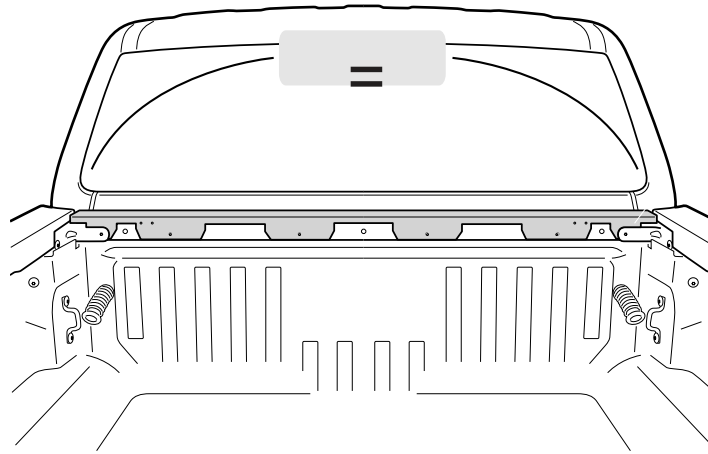

Align RHS brace bracket to the indicated threads of the tub.



If required trim top rail plastic cap to expose 2 factory threads.
Repeat to the other side.

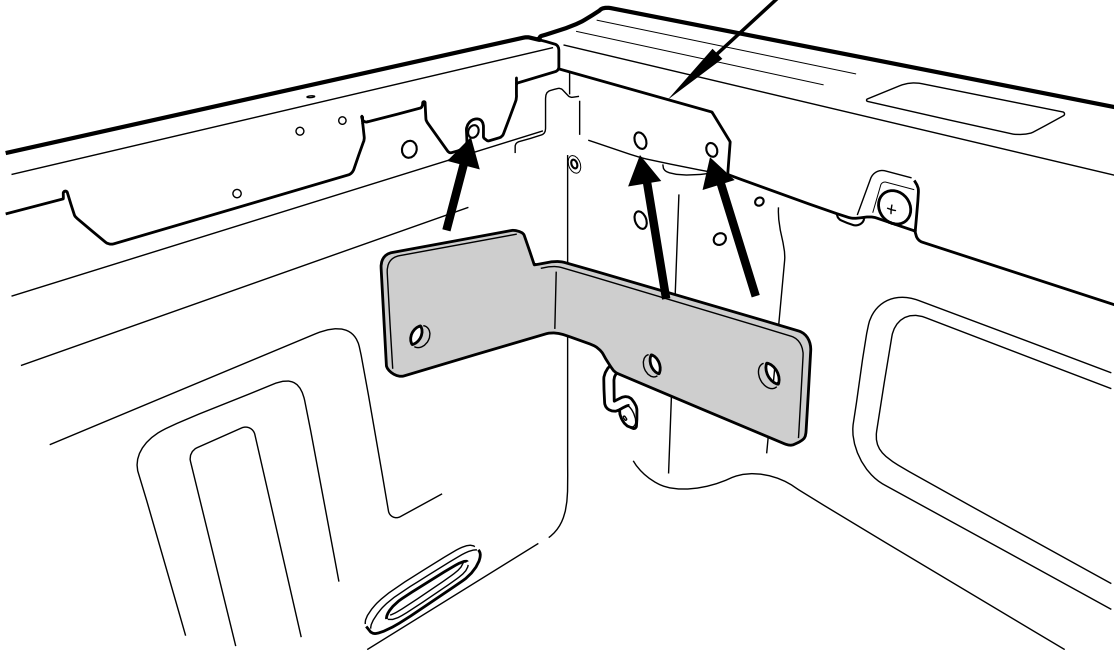

Fasten loosely into position using retained factory bolts.
If factory bolts were not provided use supplied black M8 x 30mm in the kit.

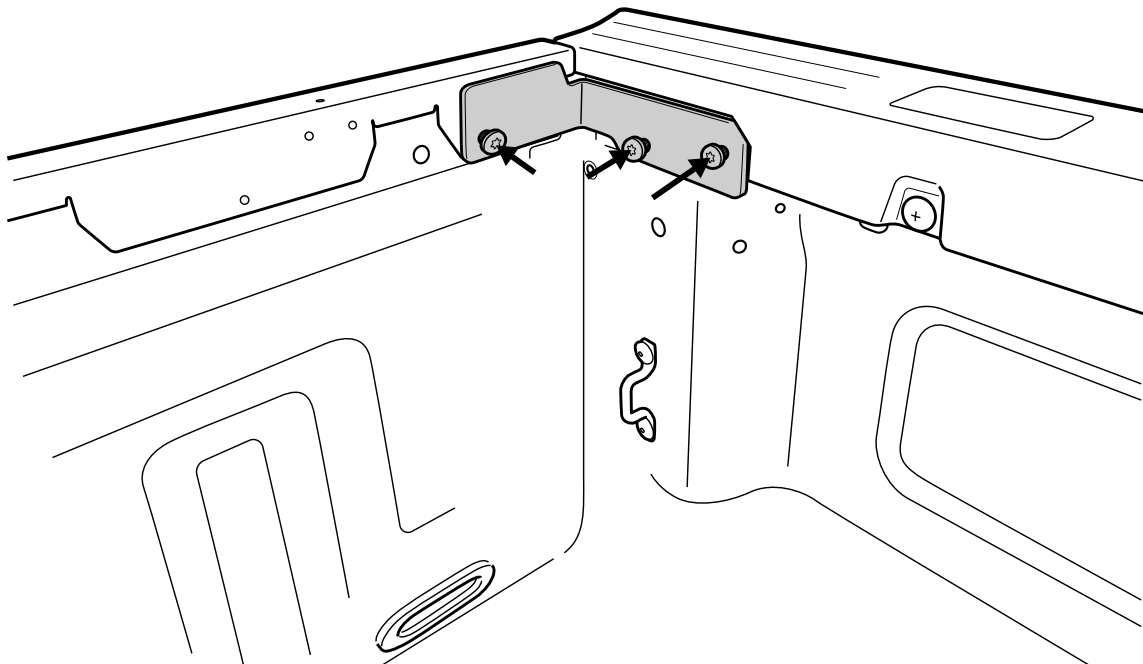

1. Fasten location **a** to 20Nm torque.
2. Fasten location **b** to 20Nm torque.

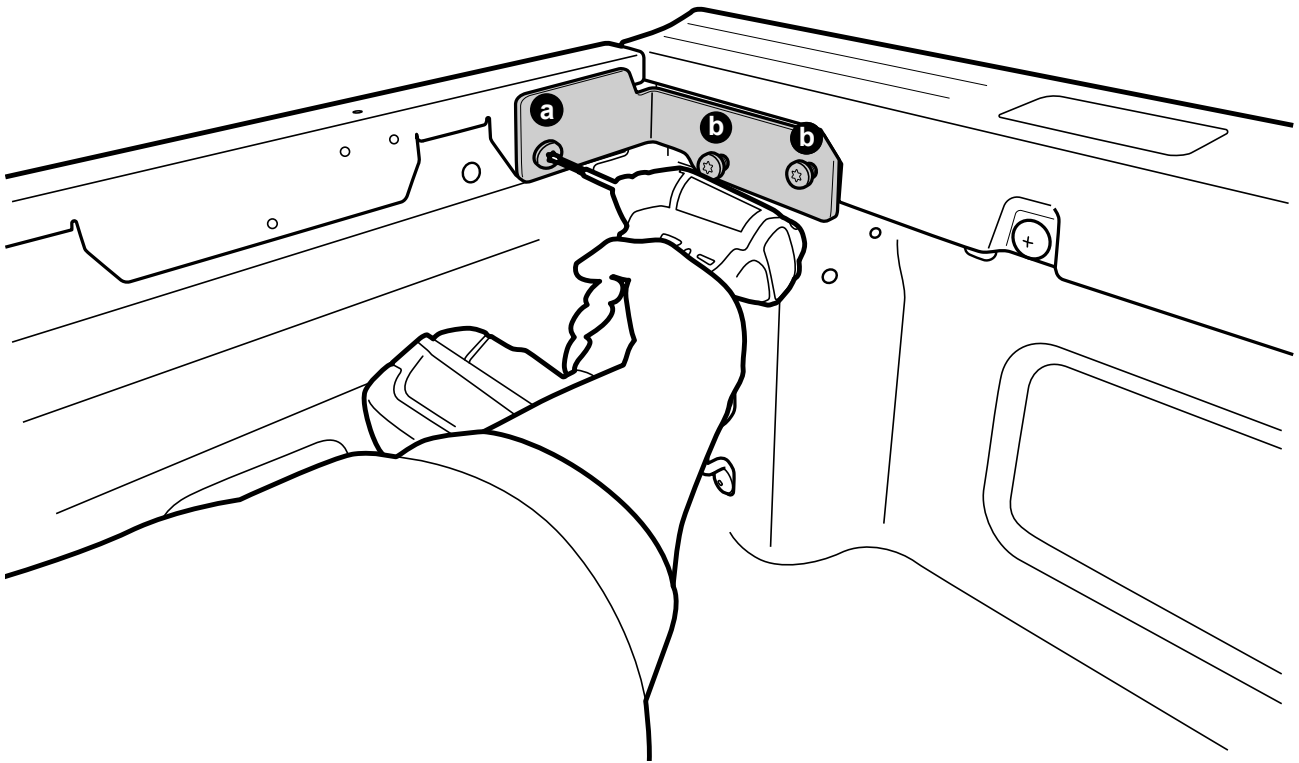

 Fasten FBA into position using supplied self drilling screw to indicated areas.

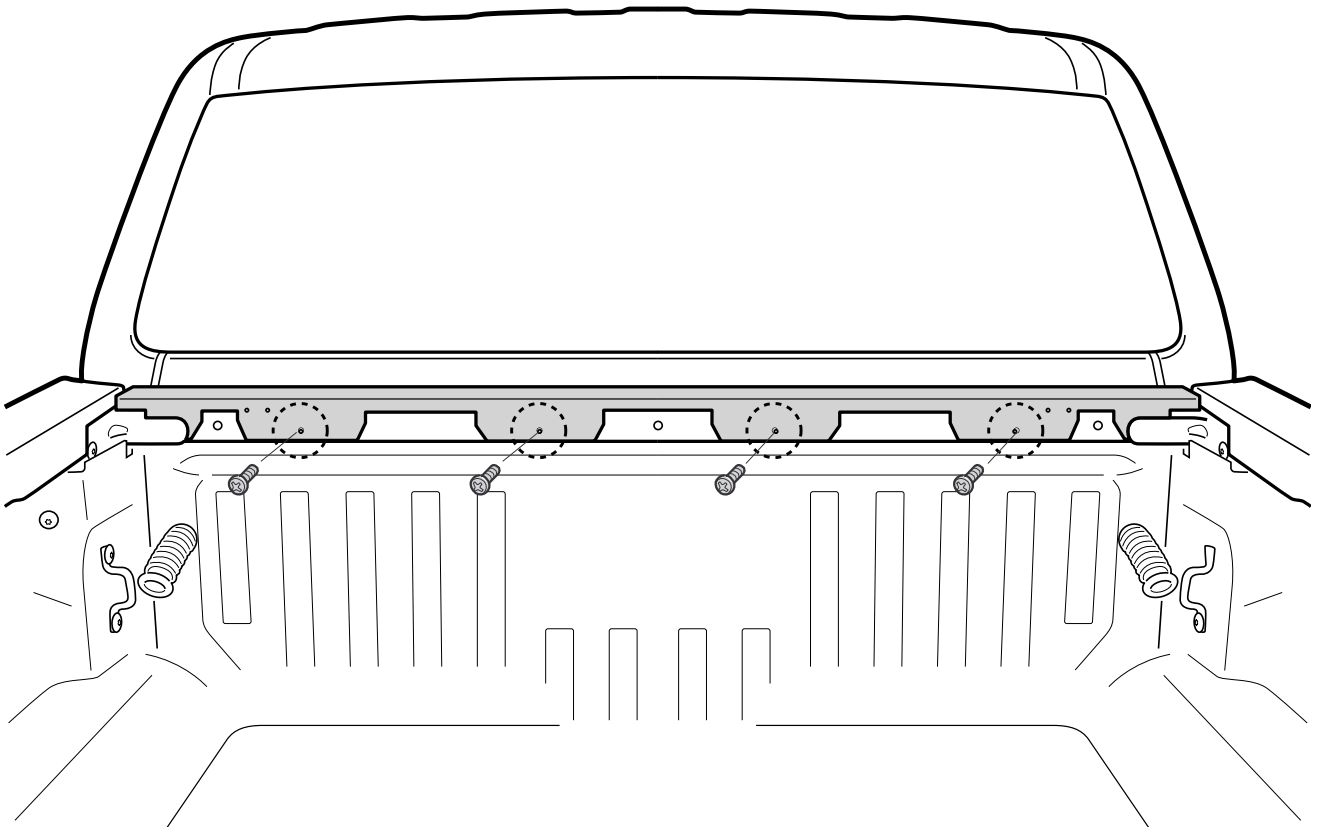

Sealing any gaps on the bed and FBA. It is recommended to use black sealant.

Apply an adequate amount of sealant to the areas indicated, then smooth sealant out.

Clean any excess sealant. Repeat to the other side.

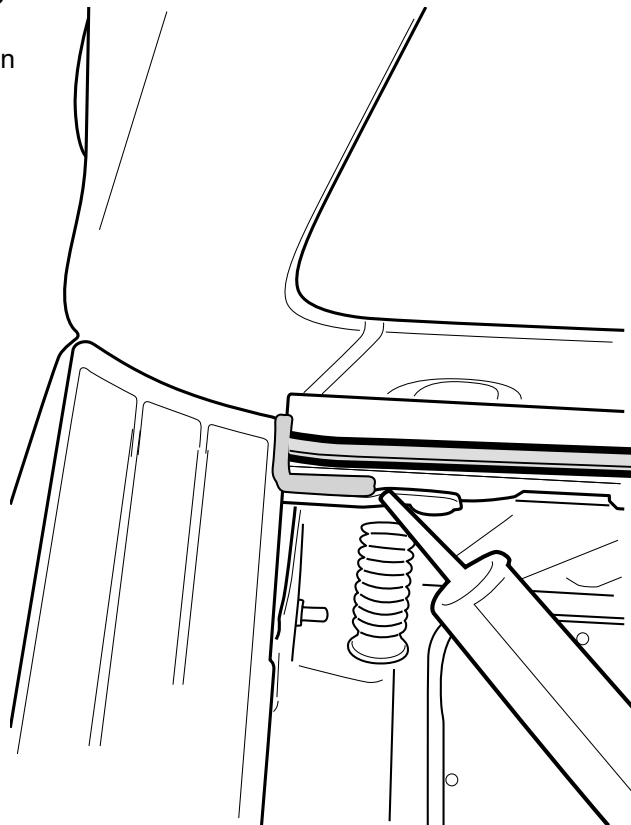

Sealing any gaps on the bed and FBA. It is recommended to use black sealant.

Apply an adequate amount of sealant to the areas indicated, then smooth sealant out.

Clean any excess sealant. Repeat to the other side.

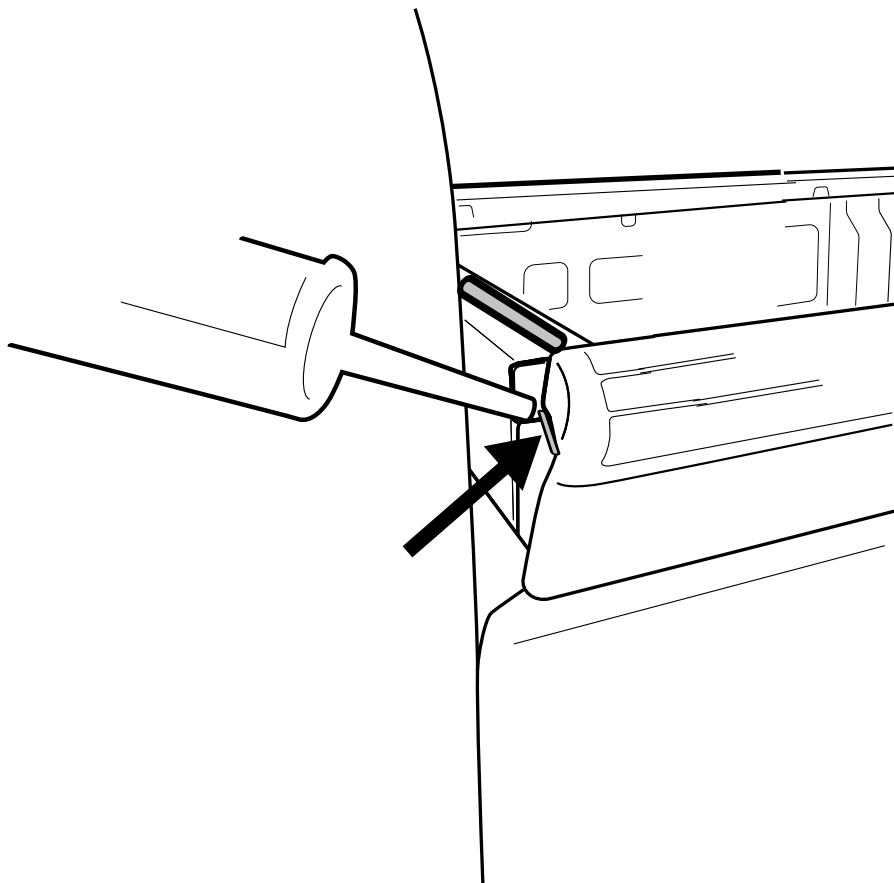

Disconnect fuse patch from battery loom S2.75.

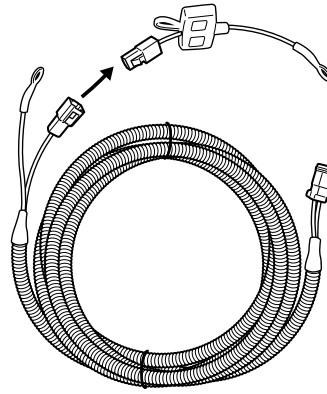

Wiring Harness steps

1 Feed Battery Loom S2.75 through the cavity

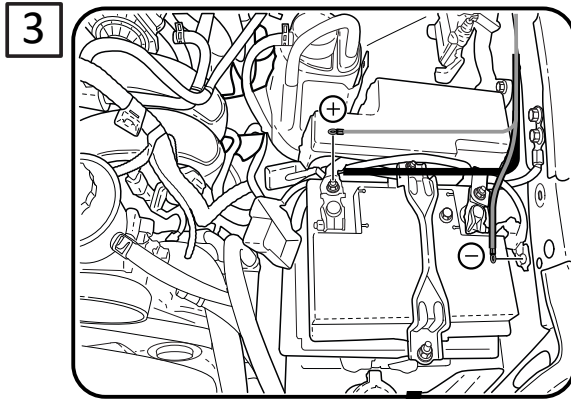
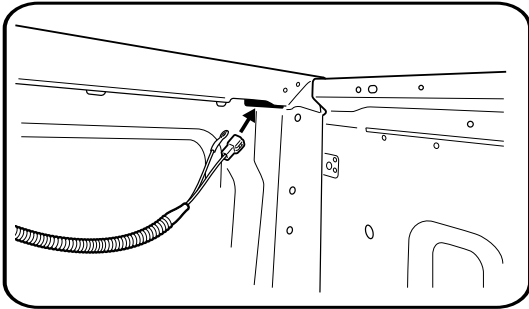

2

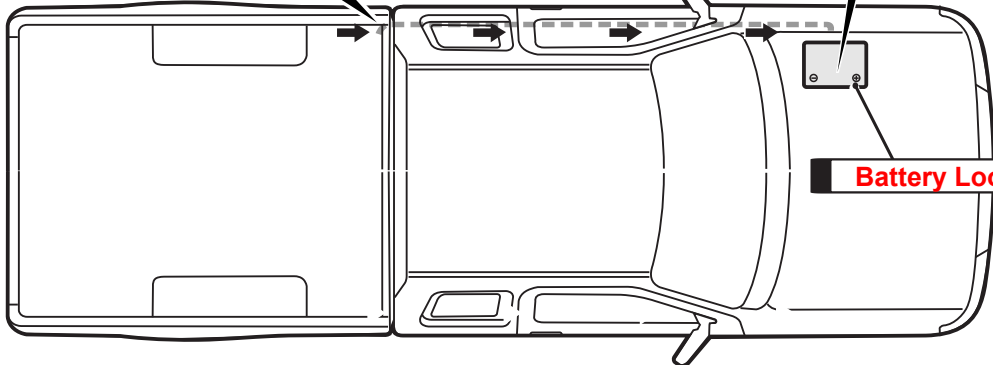

Run the wiring from the front corner cavity (leaving 200mm in the tub) to the battery over the chassis rail. Making sure to keep away from hot obstructions and cable tie every 400mm. Reconnect fuse patch to battery loom S2.75, now attach fuse patch to positive of battery and earth to the body of the Ute.

Feed CL-Short-Loom through the cavity.

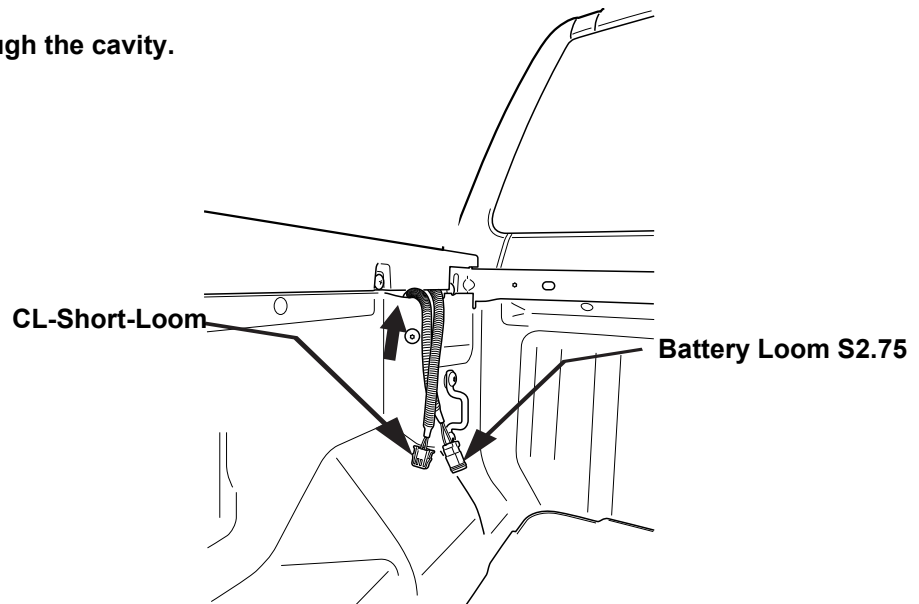

Remove required clips to gain access to passenger side rear wheel arch inner.

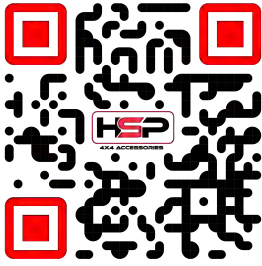

 **VISUAL TIP**

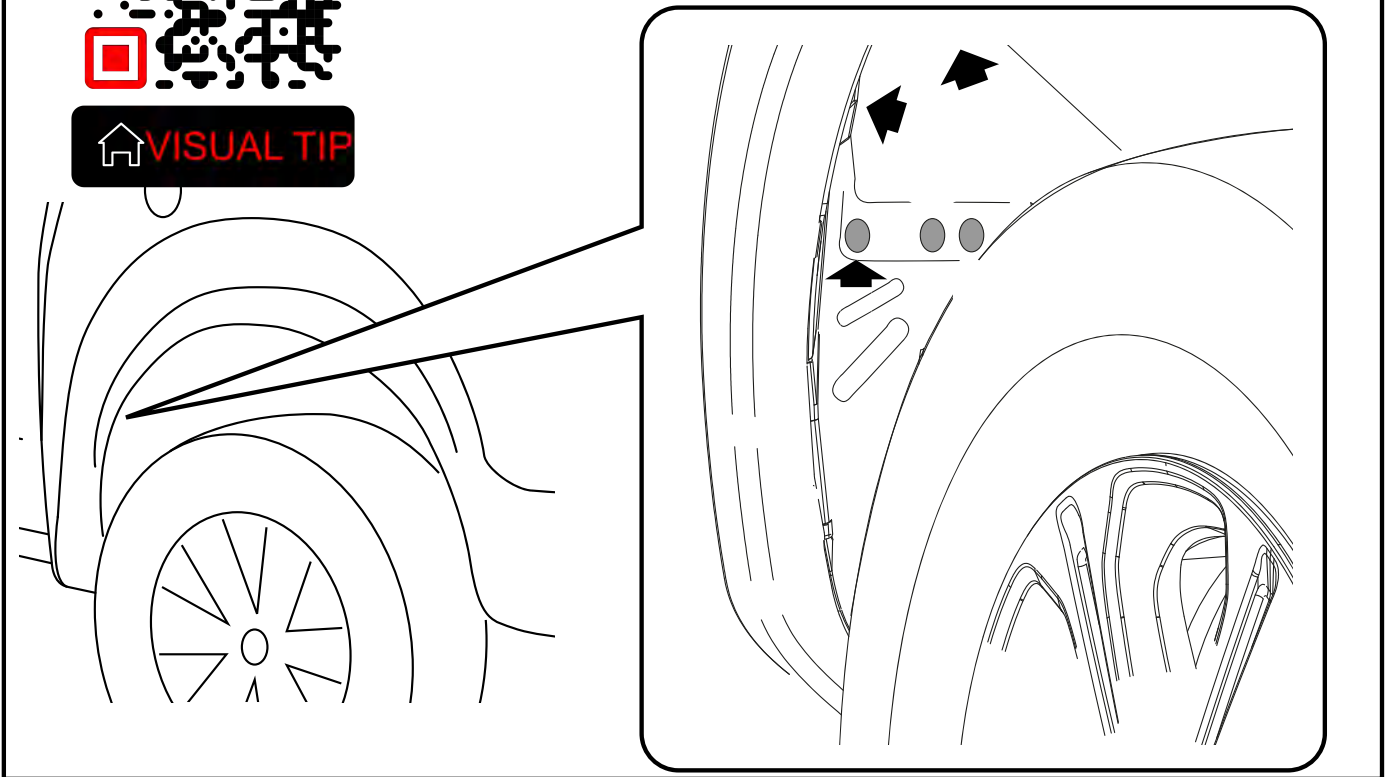

NOTE: image used is for illustration purpose only.

1. Disconnect the fuel flap actuator connector (1).
2. Patch the NGR-Patch to fuel cap actuator connector and actuator connector.
3. Use one zip tie to secure the harness to the existing harness.
4. Connect CL-Short-Loom to NGR-Patch. Zip tie any loose loom within wheel arch.

FUEL CAP ACTUATOR
CONNECTOR

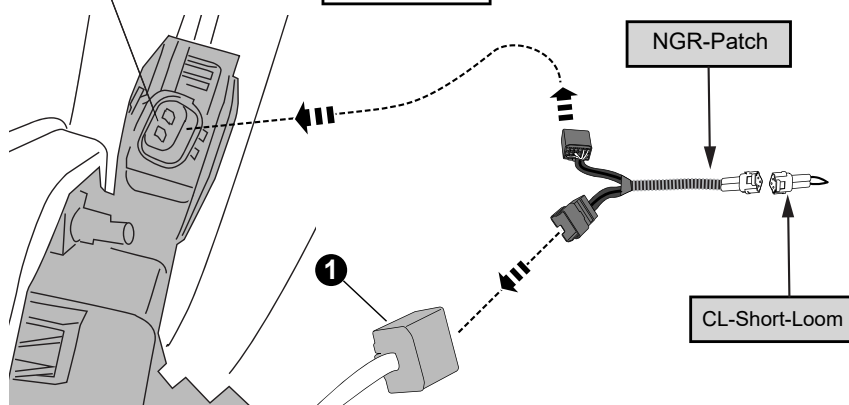
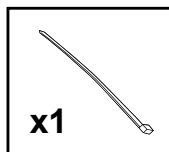

NOTE: image used is for illustration purpose only.

Keep the cannister in the foam blocks from the packaging for assembly.

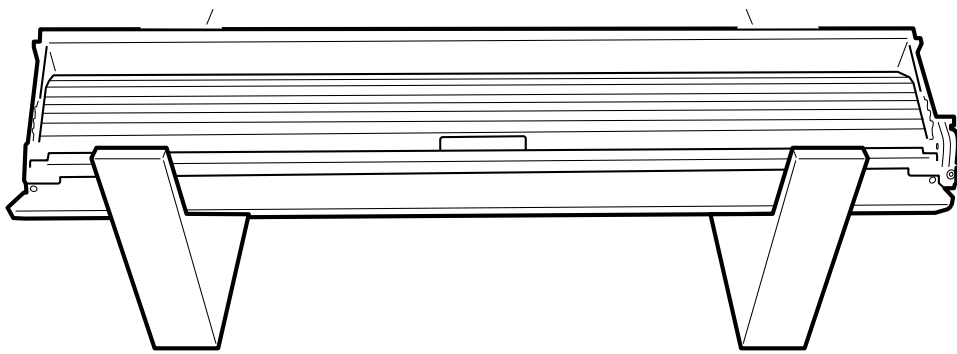
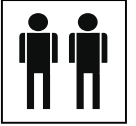

With assistance turn the canister on its back on the foam blocks.

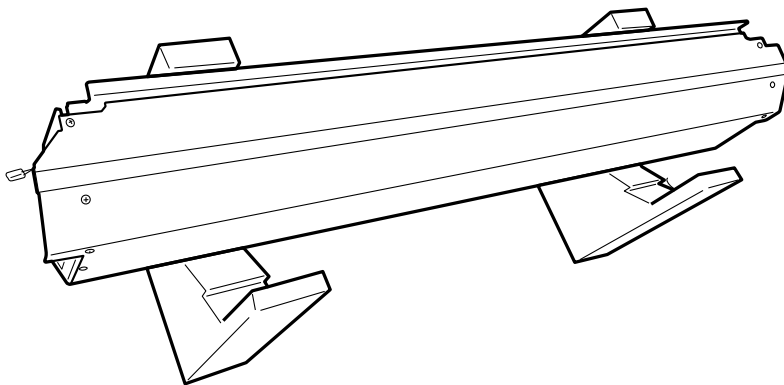

Disengage motor from the axle by unfastening the 3 Screws as indicated. Retain all parts.

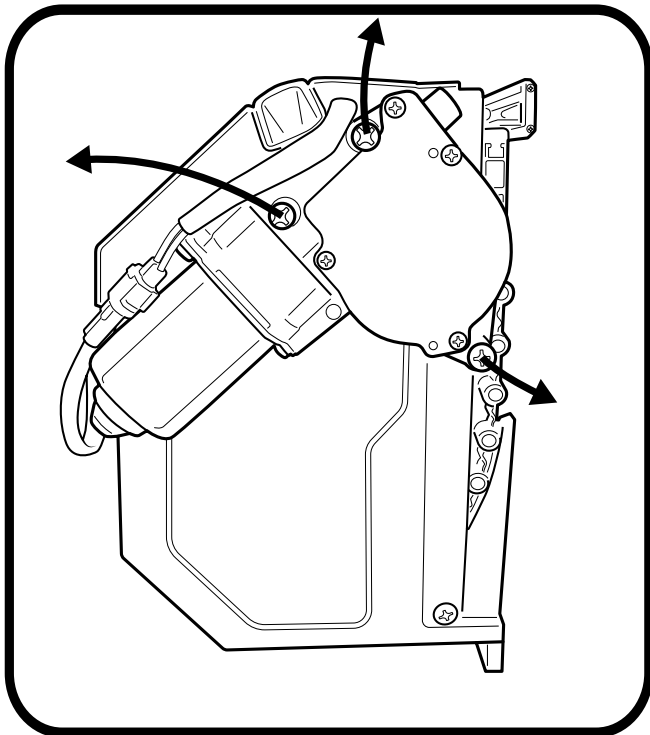

Remove and retain the 3 screw from the canister as indicated.

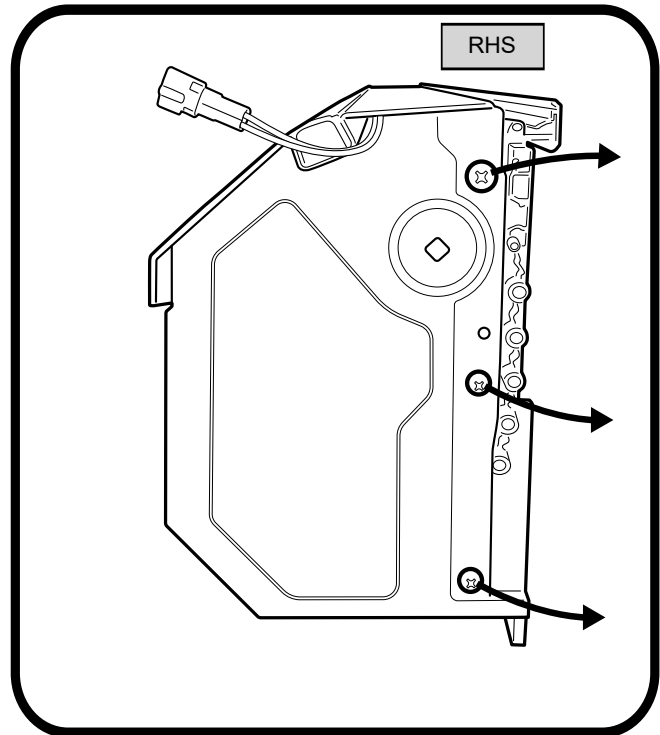
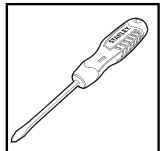

Now on the other side, remove and retain the 4 screws from the canister as indicated.

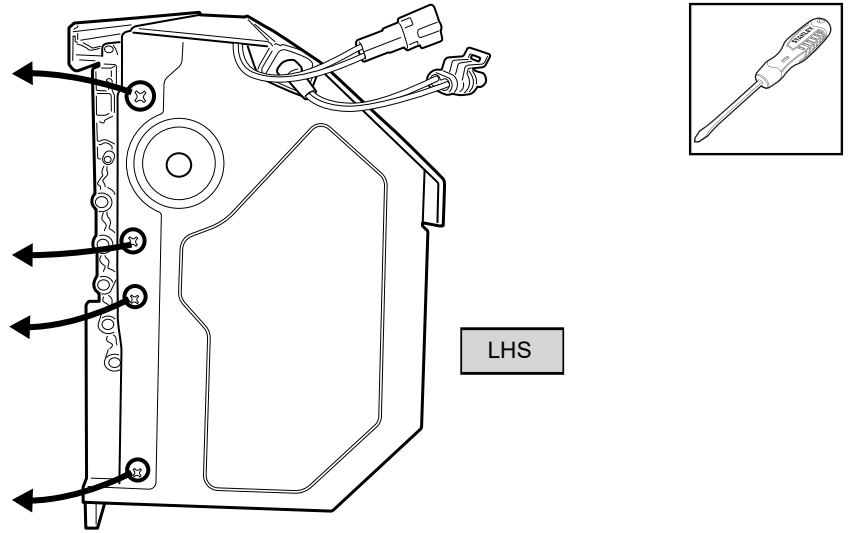

Align side rail to side of canister, guide the track to go in between the curtain end rubber stop.

NOTE: LHS side rail to be assembled first.

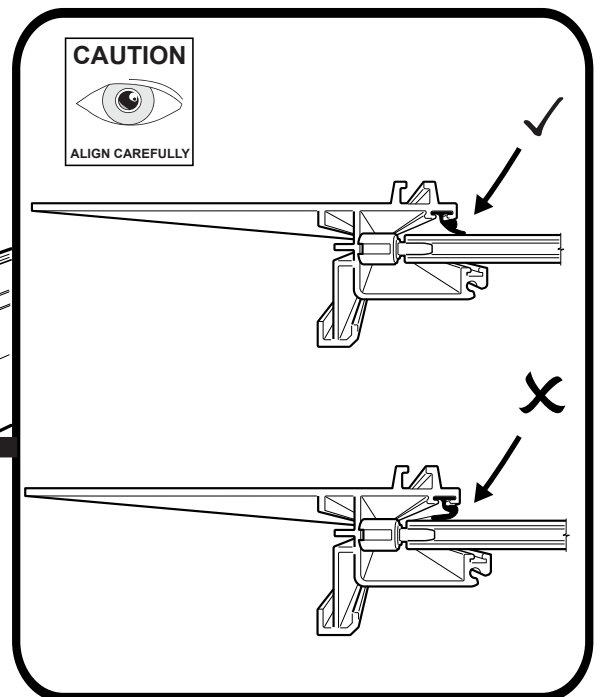
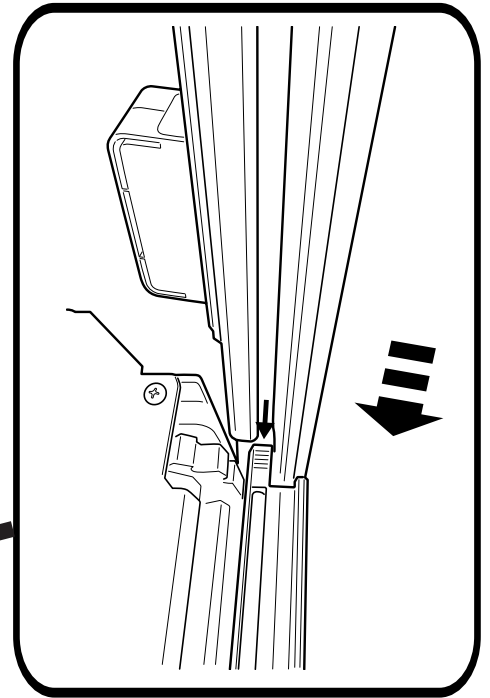
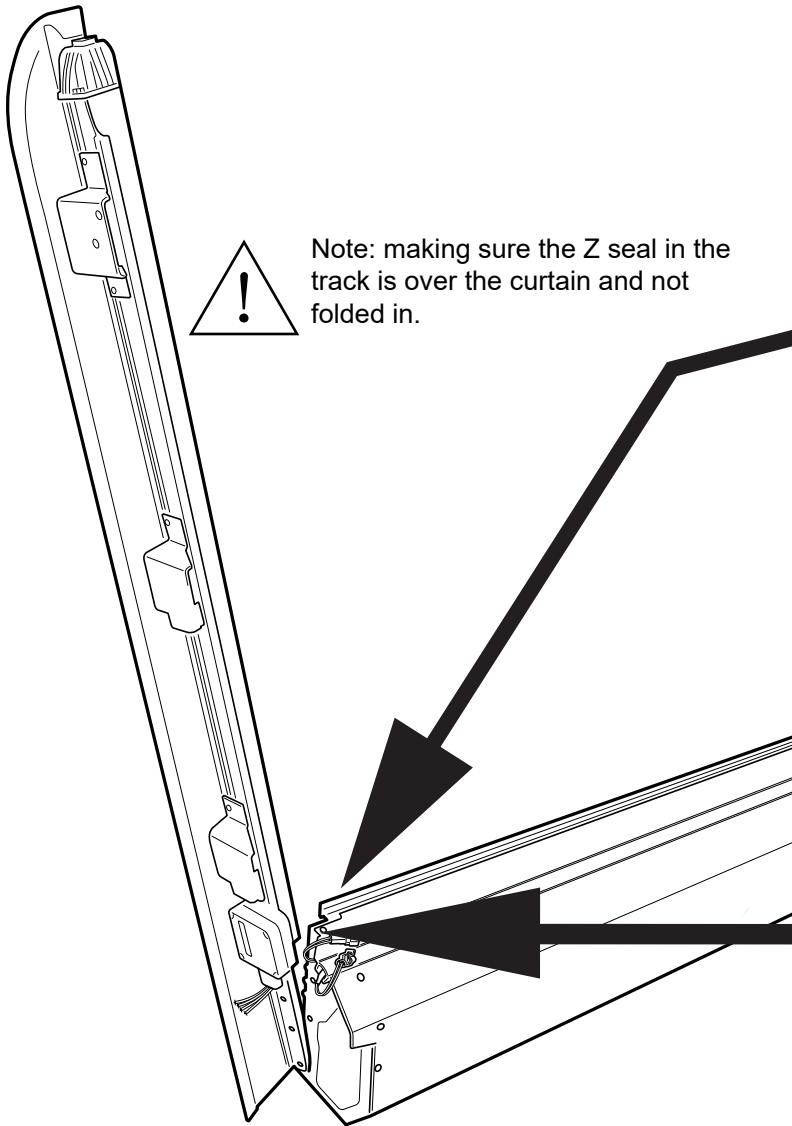

1. Using the retained screws, spring washer and washer, Loosely fasten the side rail to the location indicated.
2. Side rail edge must compress and meet with the canister profile as indicated below.
3. Fasten all screws tight.

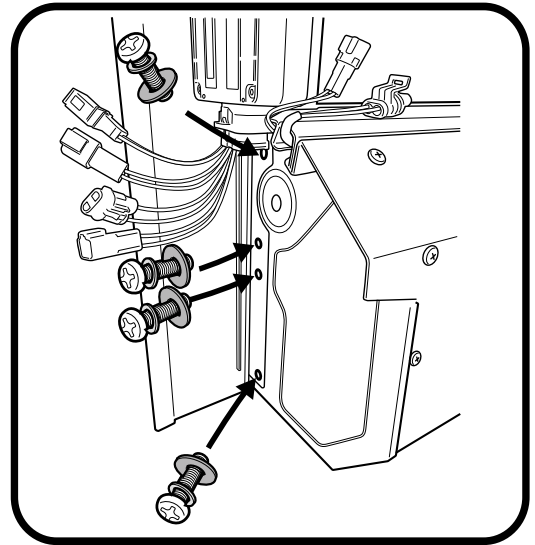
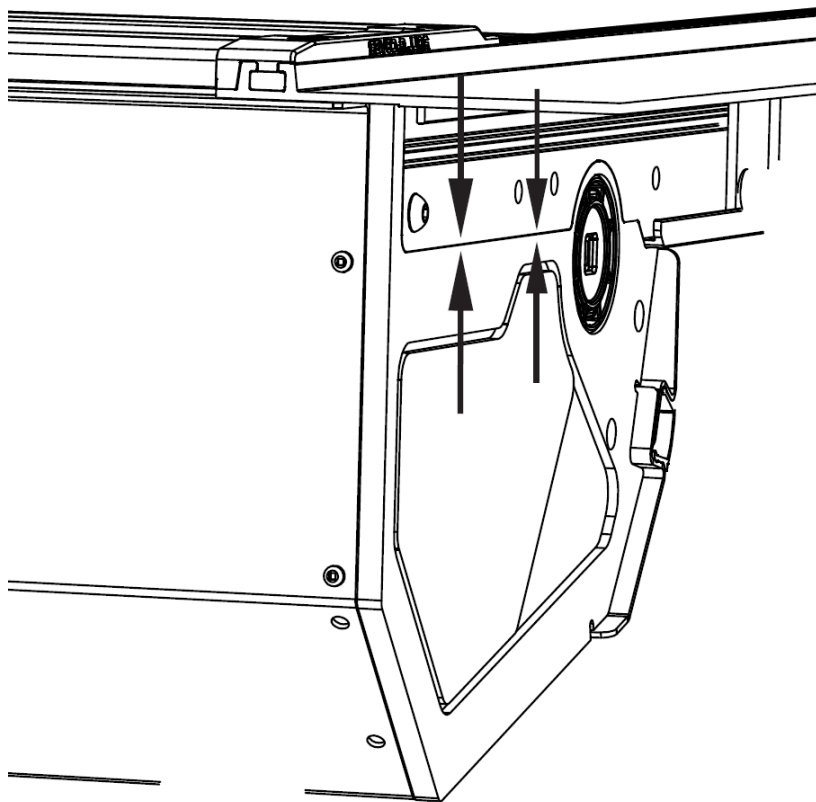
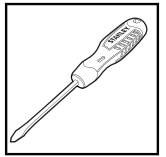

Connect motor connector to receiver

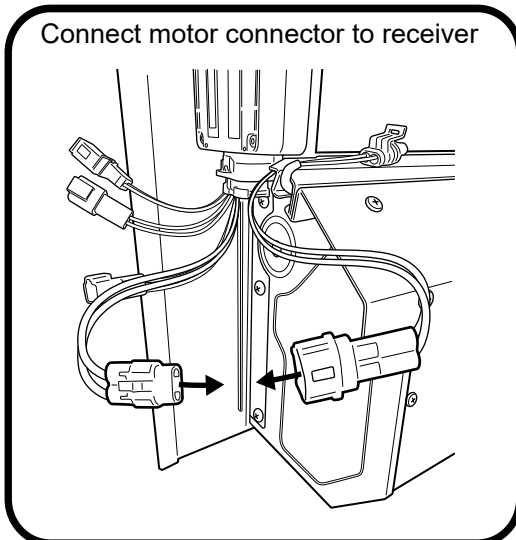

Connect LED Loom to receiver

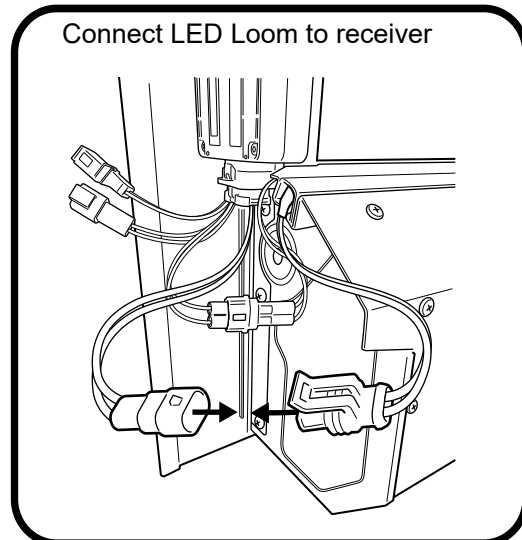

Align side rail to side of canister, guide the track to go in between the curtain end rubber stop.

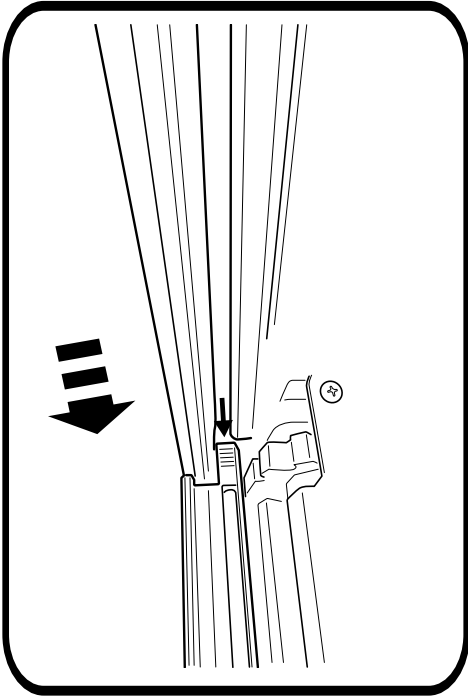

Note: making sure the Z seal in the track is over the curtain and not folded in.

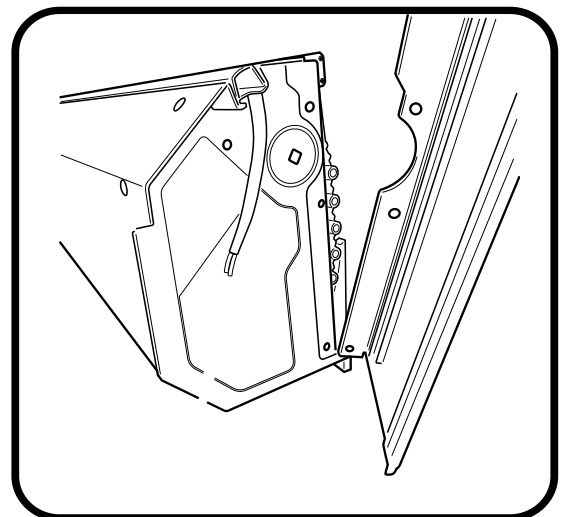
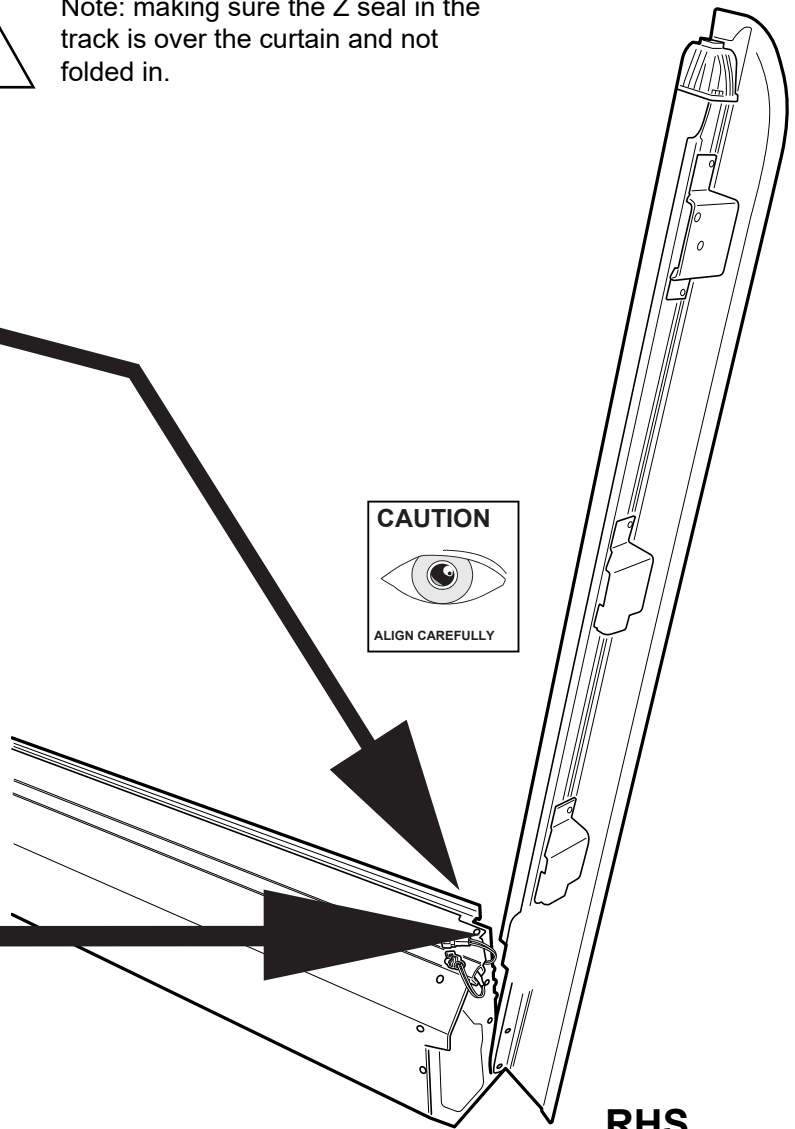
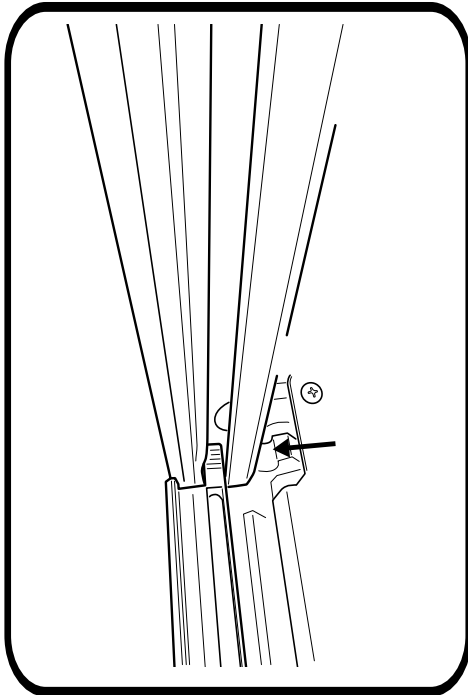

1. Using the retained screws, spring washer and washer, Loosely fasten the side rail to the location indicated.
2. Side rail edge must compress and meet with the canister profile as indicated below.
3. Fasten all screws tight.

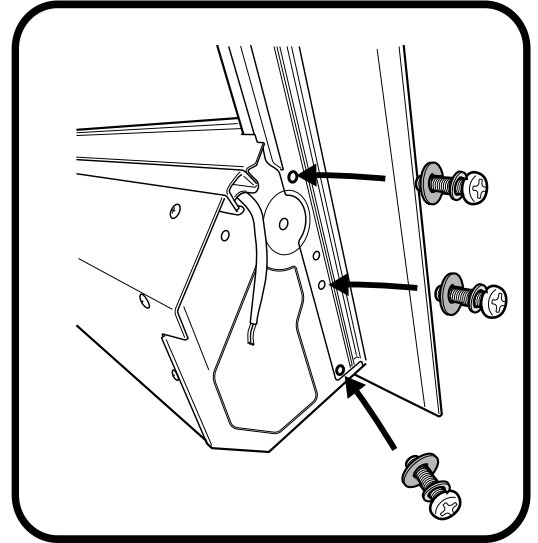
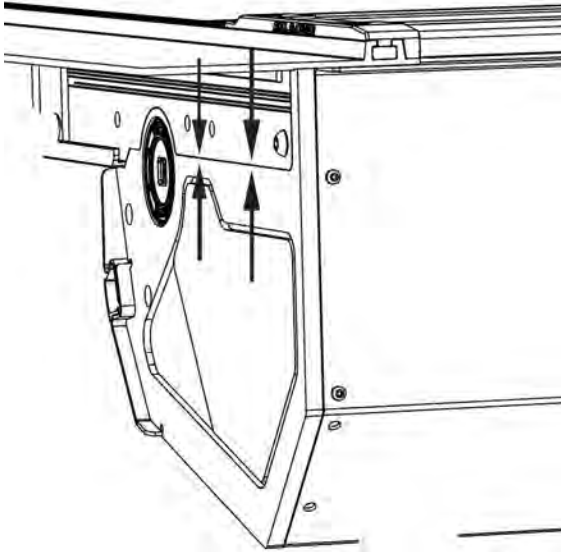
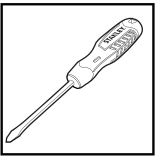

Feed M6 bolt through spring washer, motor and rubber bush.

NOTE: Rubber bush orientation has to be as per image. (side with text on rubber, to face the motor).

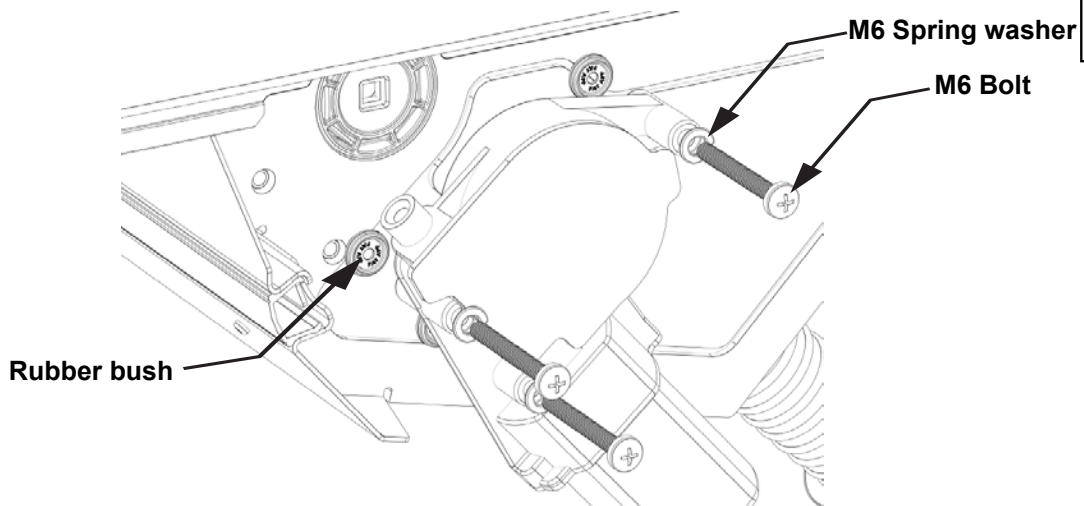

Align & insert motor shaft to axle.

NOTE: Pull / push curtain for axle to rotate.

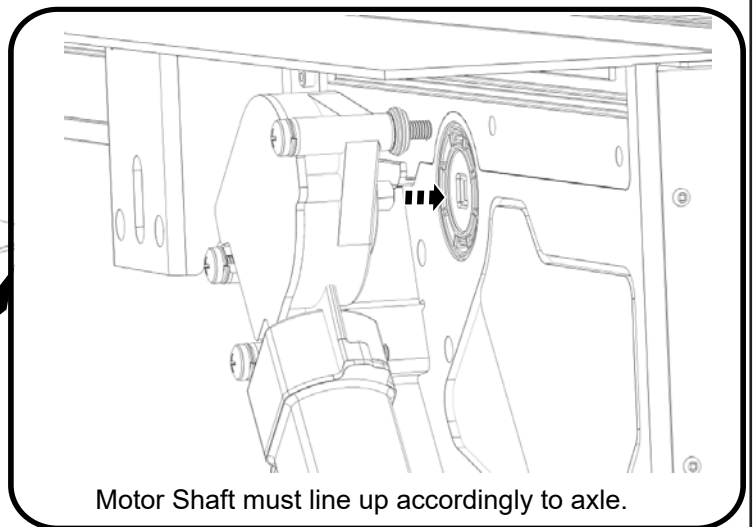
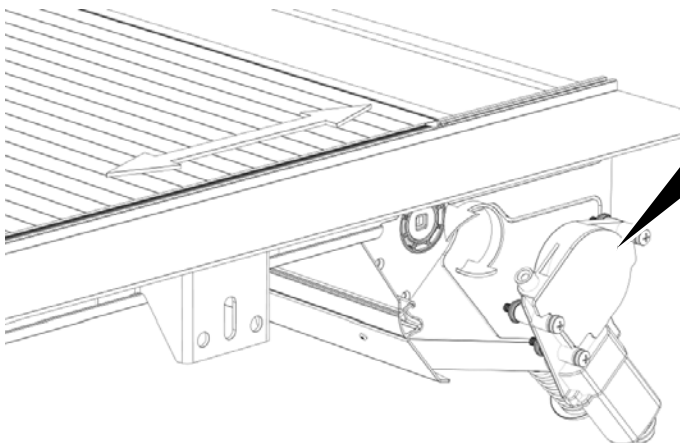

Fasten all 3 screws to 2nm torque. Over tensioning will cause operating issue's.

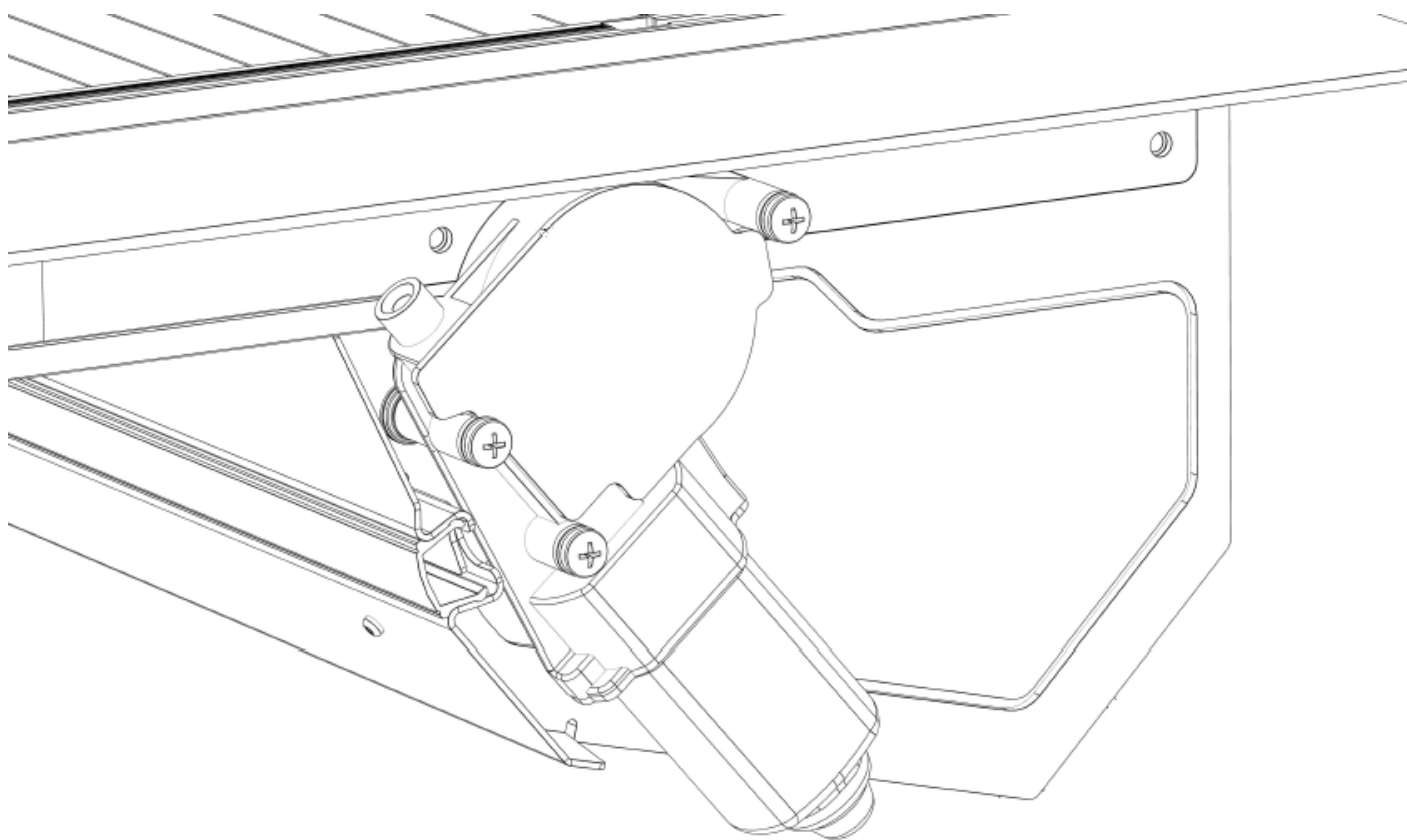
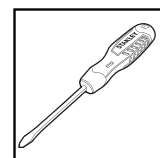

Motor is to sit level.

Any obstructions between motor and canister may cause operating issues.

Carefully bring down the assembled unit.

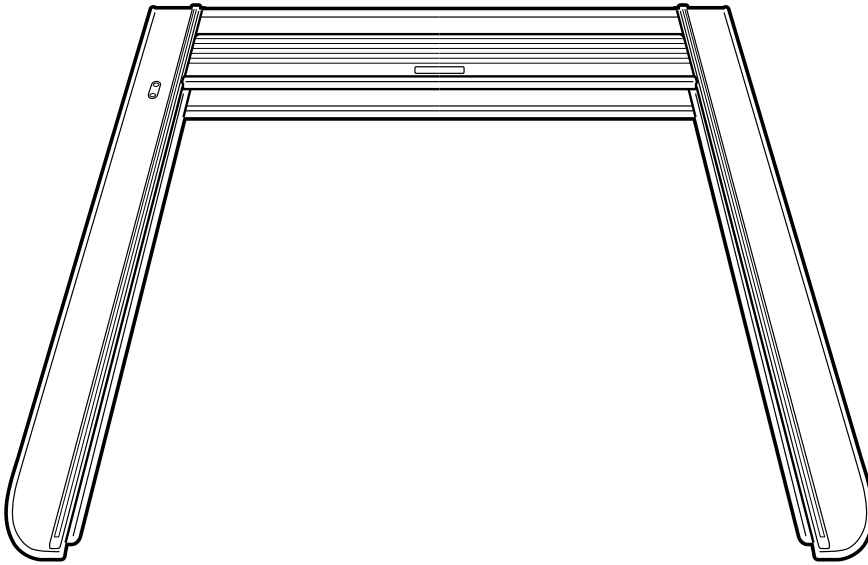

Insert side end caps to the top cover.

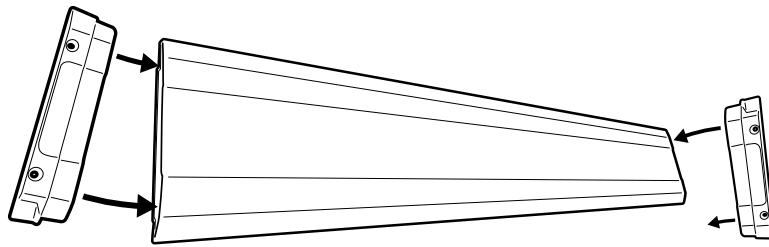

Place & Align top cover over the canister and side rails.

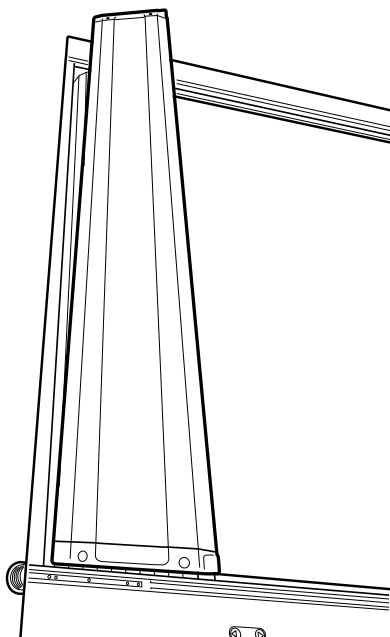

Using countersunk screws provided, line up end cap holes to the threads on the side rail. Fasten to 3nm torque. Repeat to the other side.

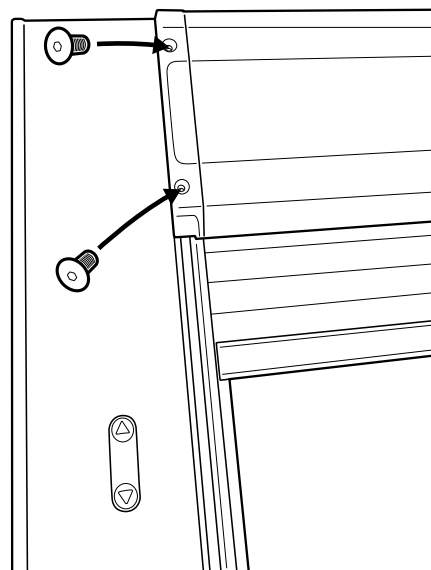

Apply 3M primer provided around all side rail holes.

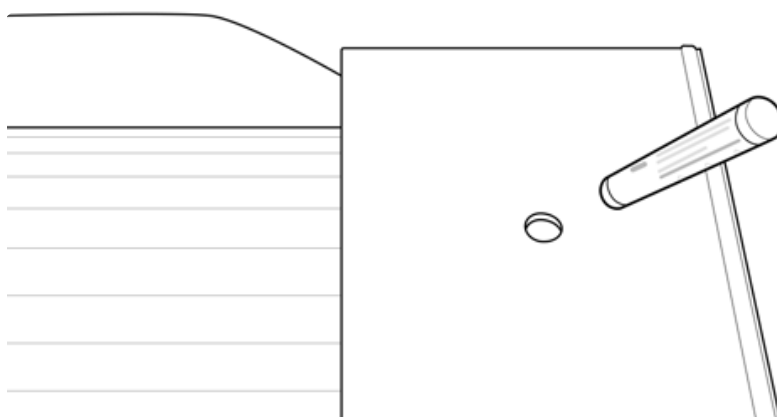

Peel away backing from foam sealant and stick to side rail. Repeat on all 4 locations.

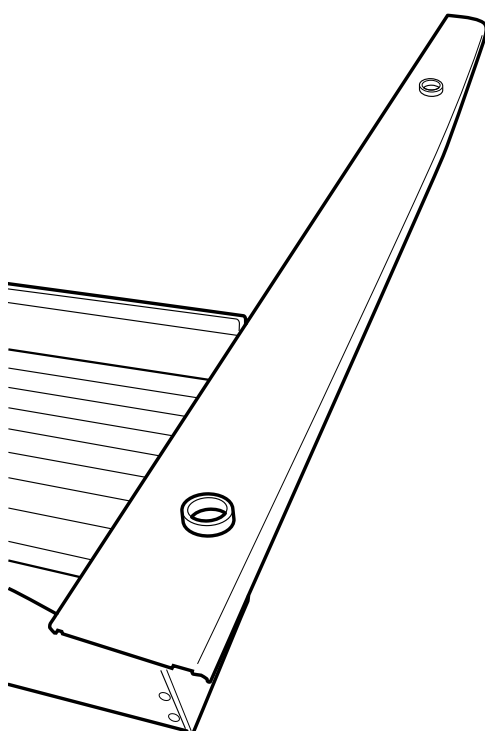
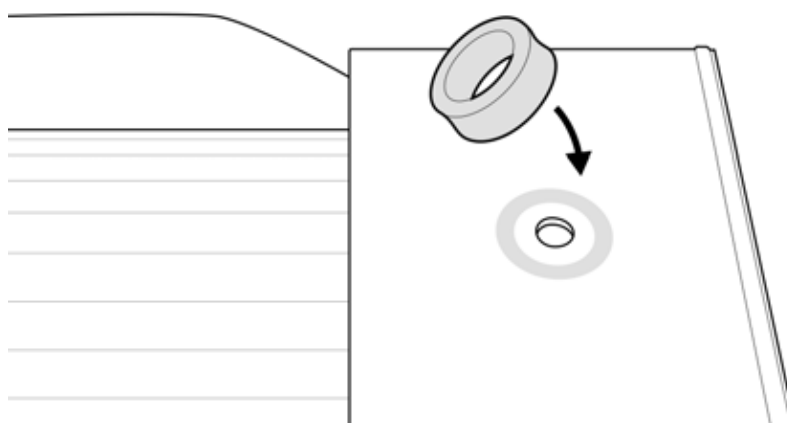

Remove and retain M6x20 Allen head bolt, M6 spring washer and M6 large washer.

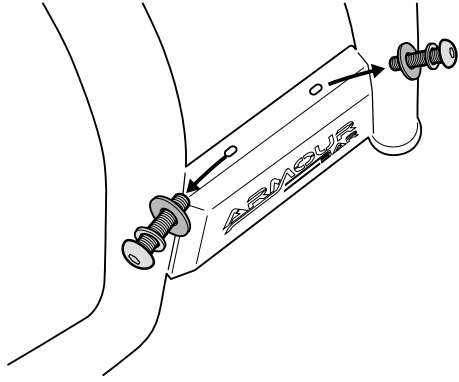

Remove back cover for side plate indicated.

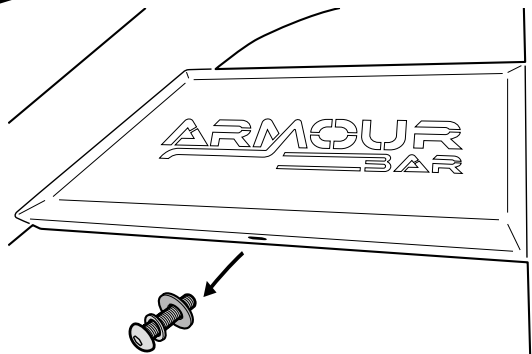
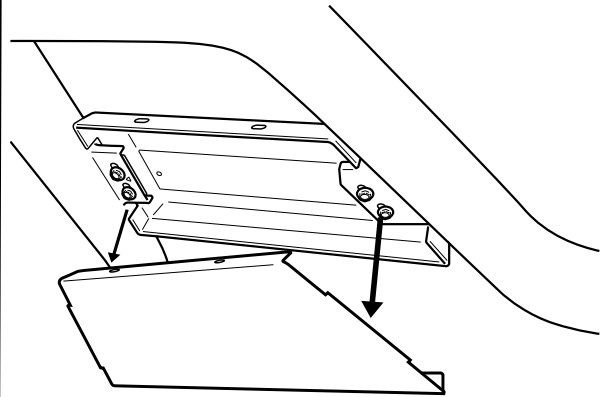

Repeat above step to the other side.

Loosen the bolts indicated.

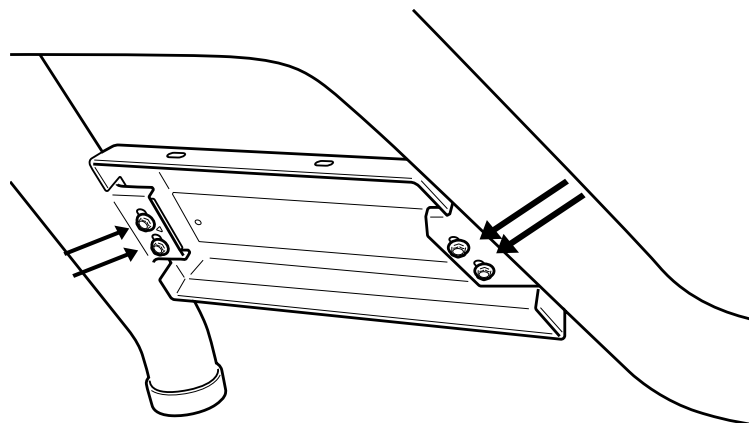

Repeat above step to the other side.

Feed the brake light loom through the allocated side rail hole.
Place Sportsbar on Roll R cover.

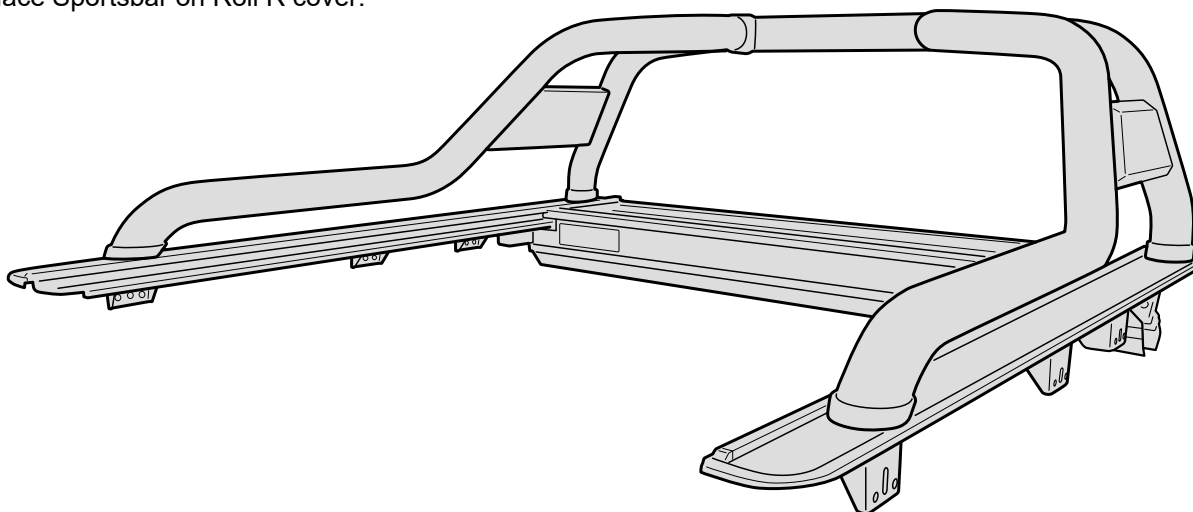

Loosely fasten sports bars to roll r cover side rails using M8 x 40mm counter sunk Allen head, followed by M8 large m8 flat washer. Repeat to all other legs.

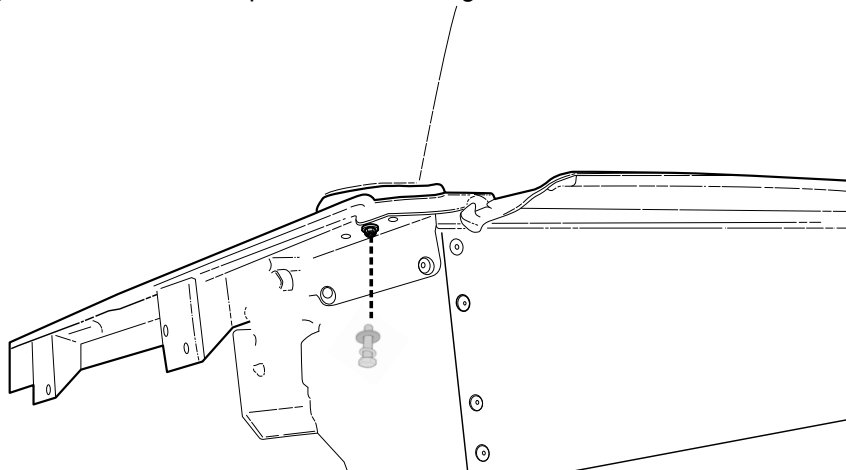

Center the sports bars on the roll top and fasten all four points.

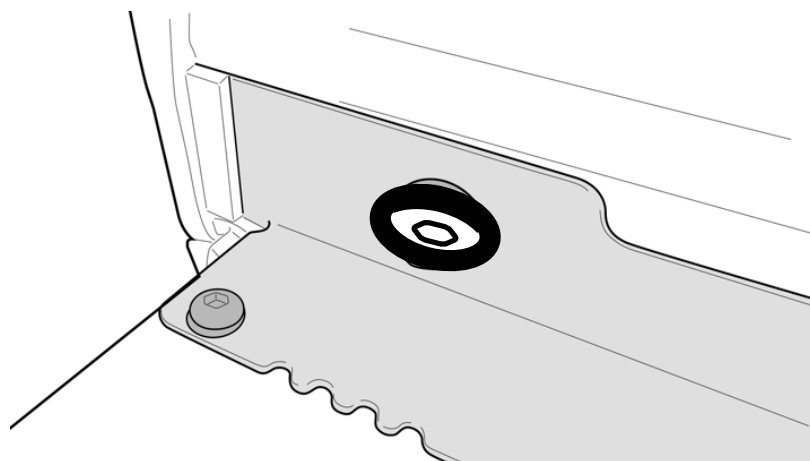

Place the Roll-R-Cover unit on to Ute bed.

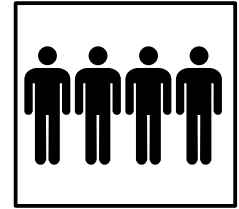
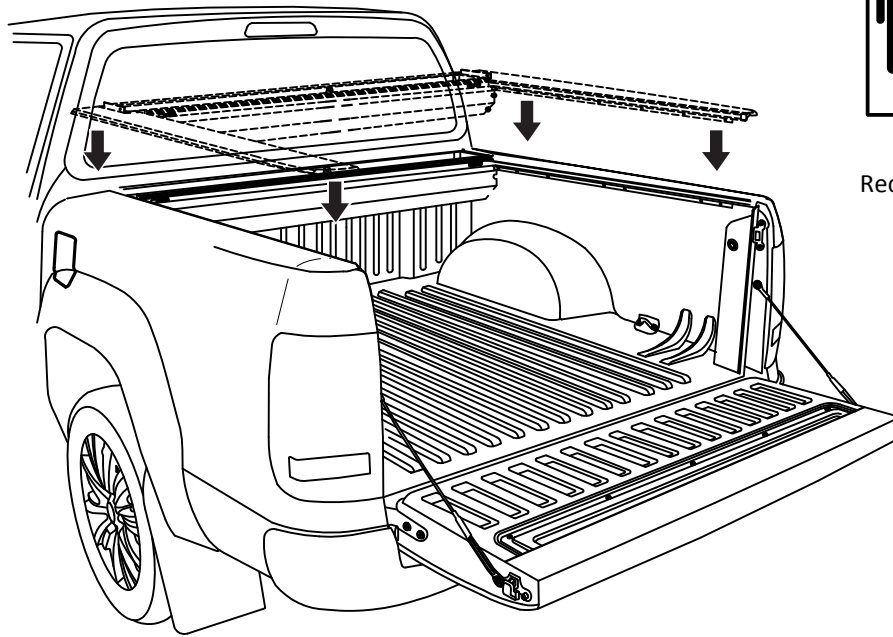

4 People
Recommended for lift

With care, pull out any side rubber
that has folded under the side rail.

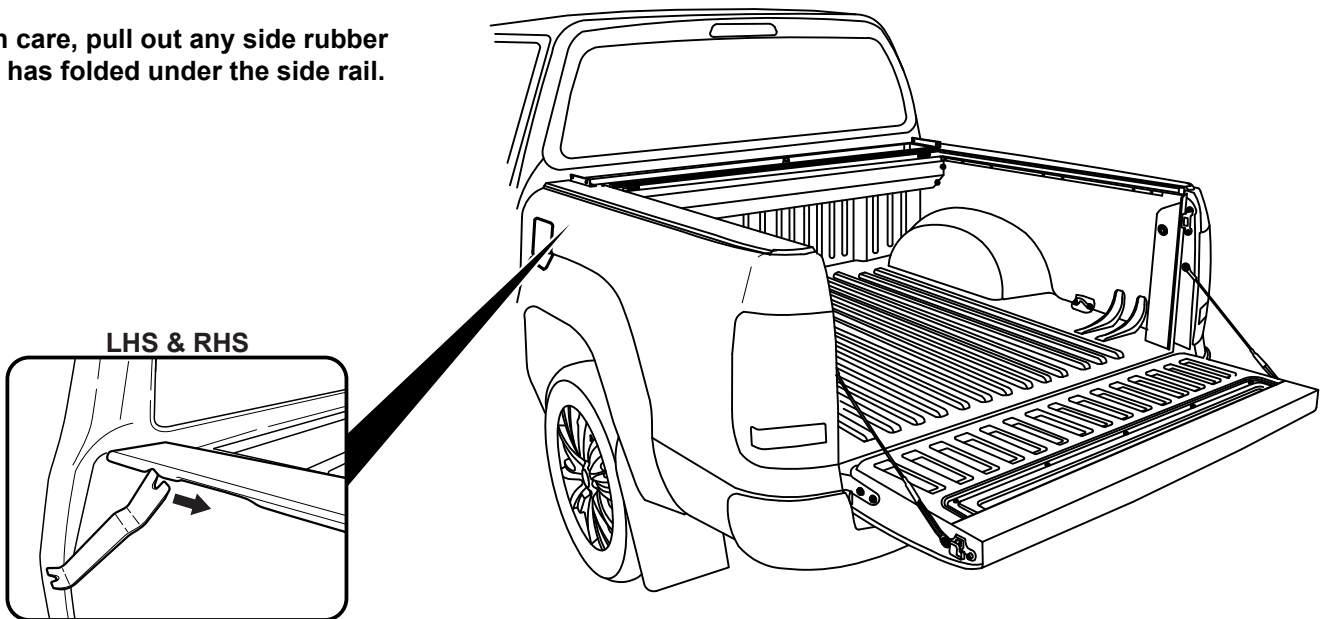

With the tailgate up (Closed position), Pull left & right hand side rails towards the tailgate, stopping short by 7mm between tailgates plastic top covers inner wall and side-rail end-cap.

 Foam compressed to 7mm when tailgate is closed.

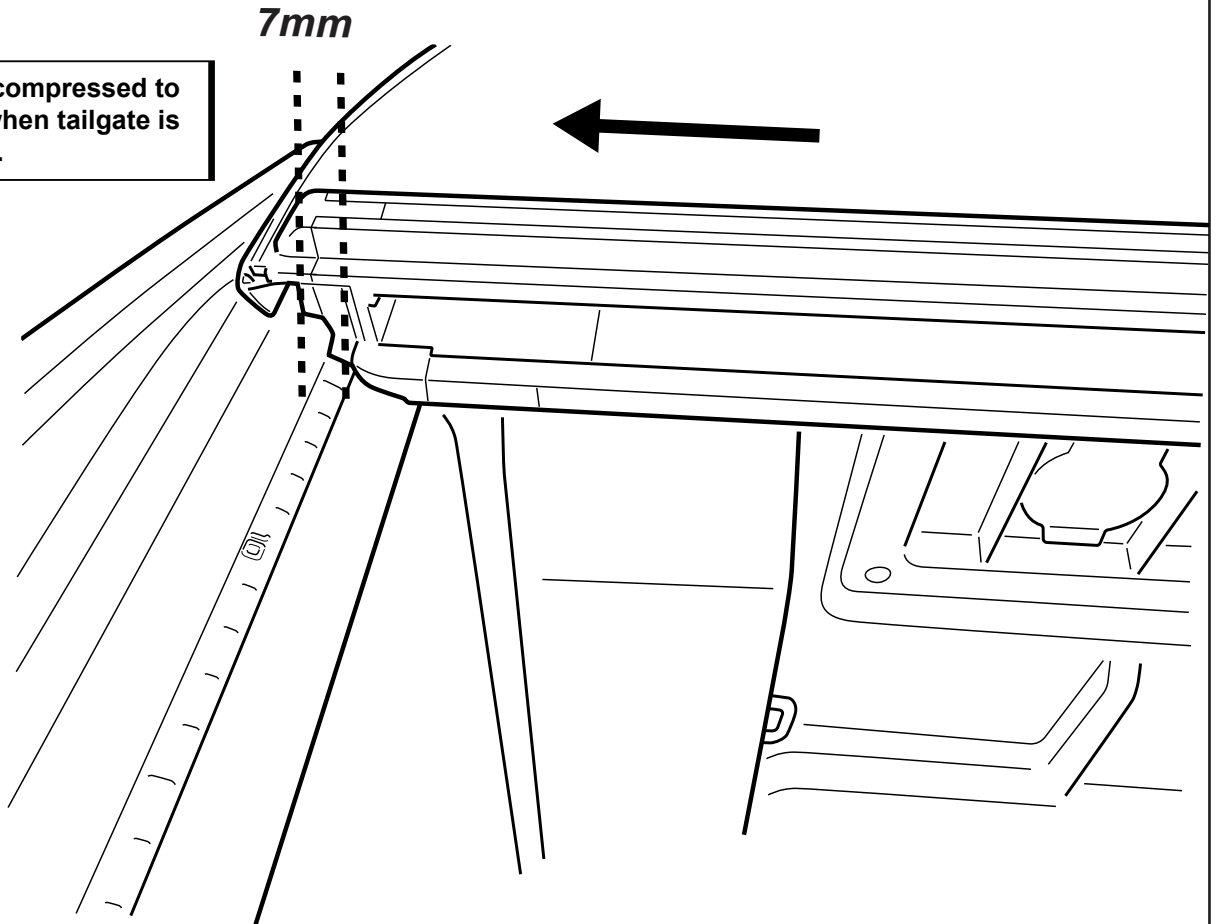

Gap between tailgate and side-rail end cap to be 7mm.

Side rail end cap

 Foam compressed to 7mm when tailgate is closed.

Foam seal

TAILGATE

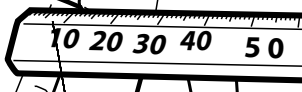

7mm

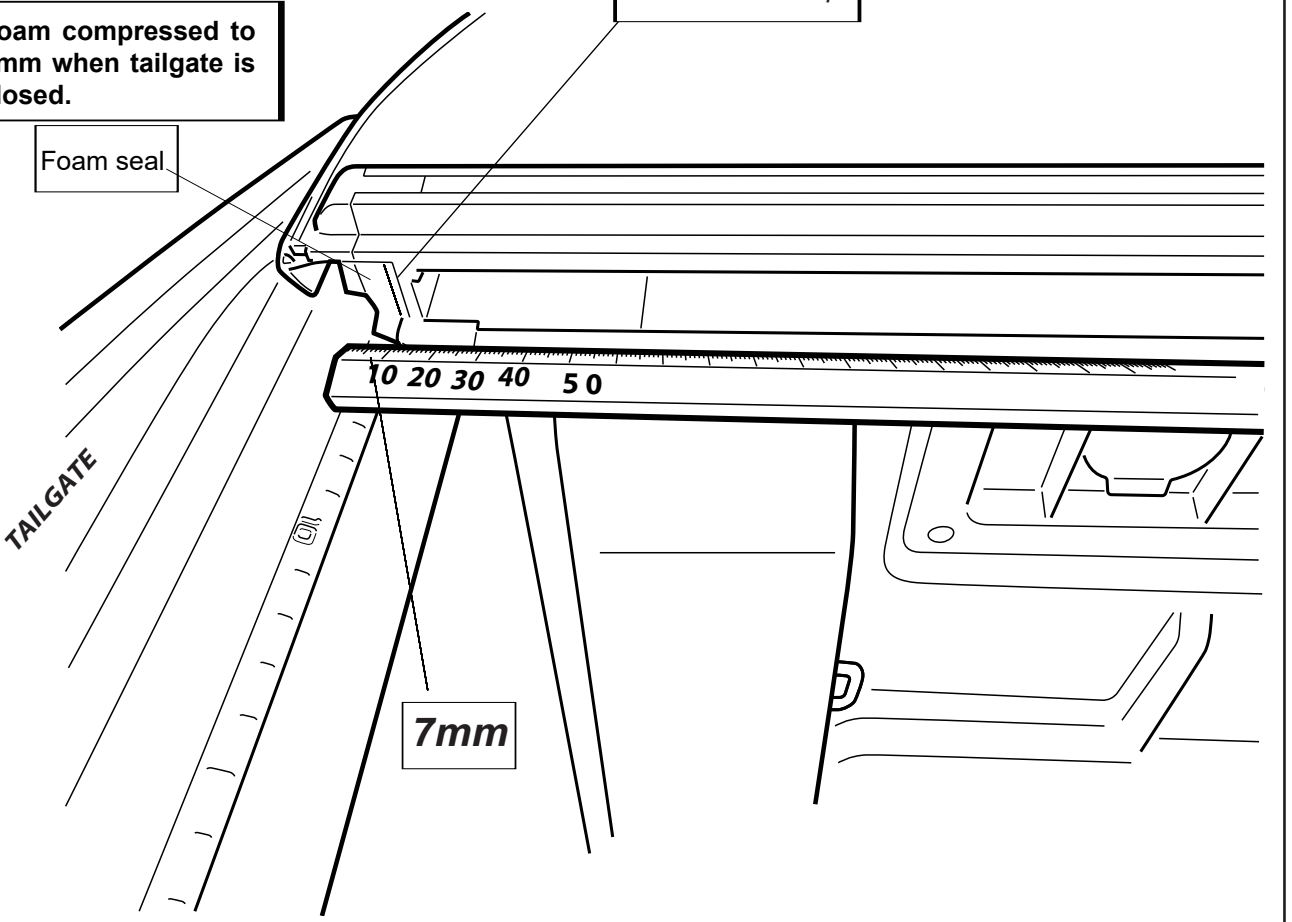

Locate spacers with 1 notch to the areas indicated.
Push the spacer up and level with the side rail clamp bracket as indicated.

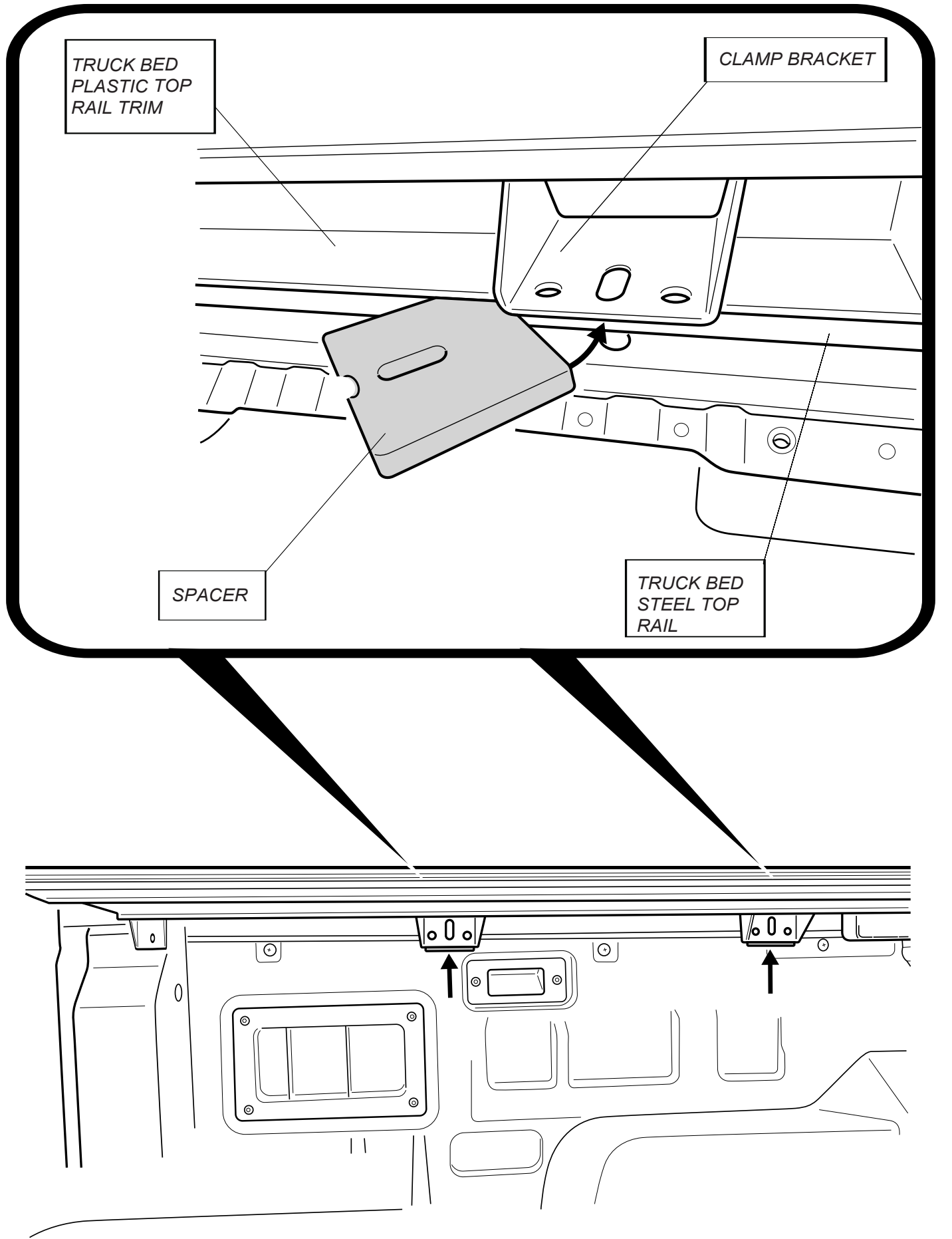

1. Rear brackets elongated hole will line up with the thread in the body as indicated.
2. Feed M6x25mm hex head bolt followed by M6 spring washer and M6 flat washer through bracket and loosely fasten to the thread of the ute bed.

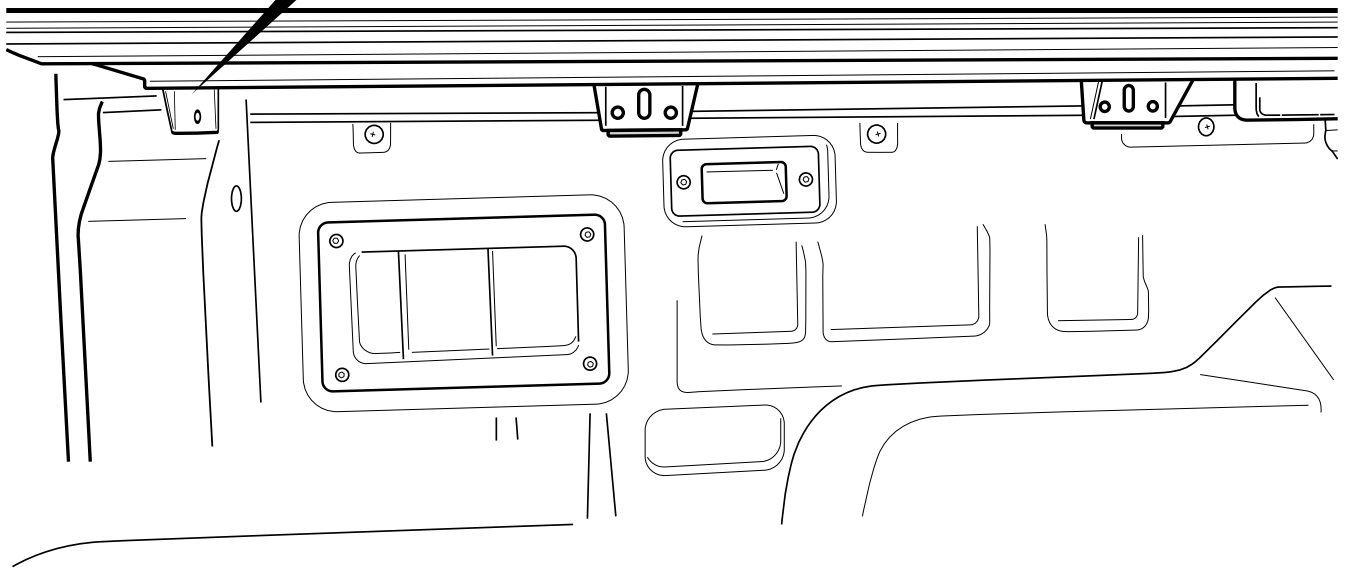
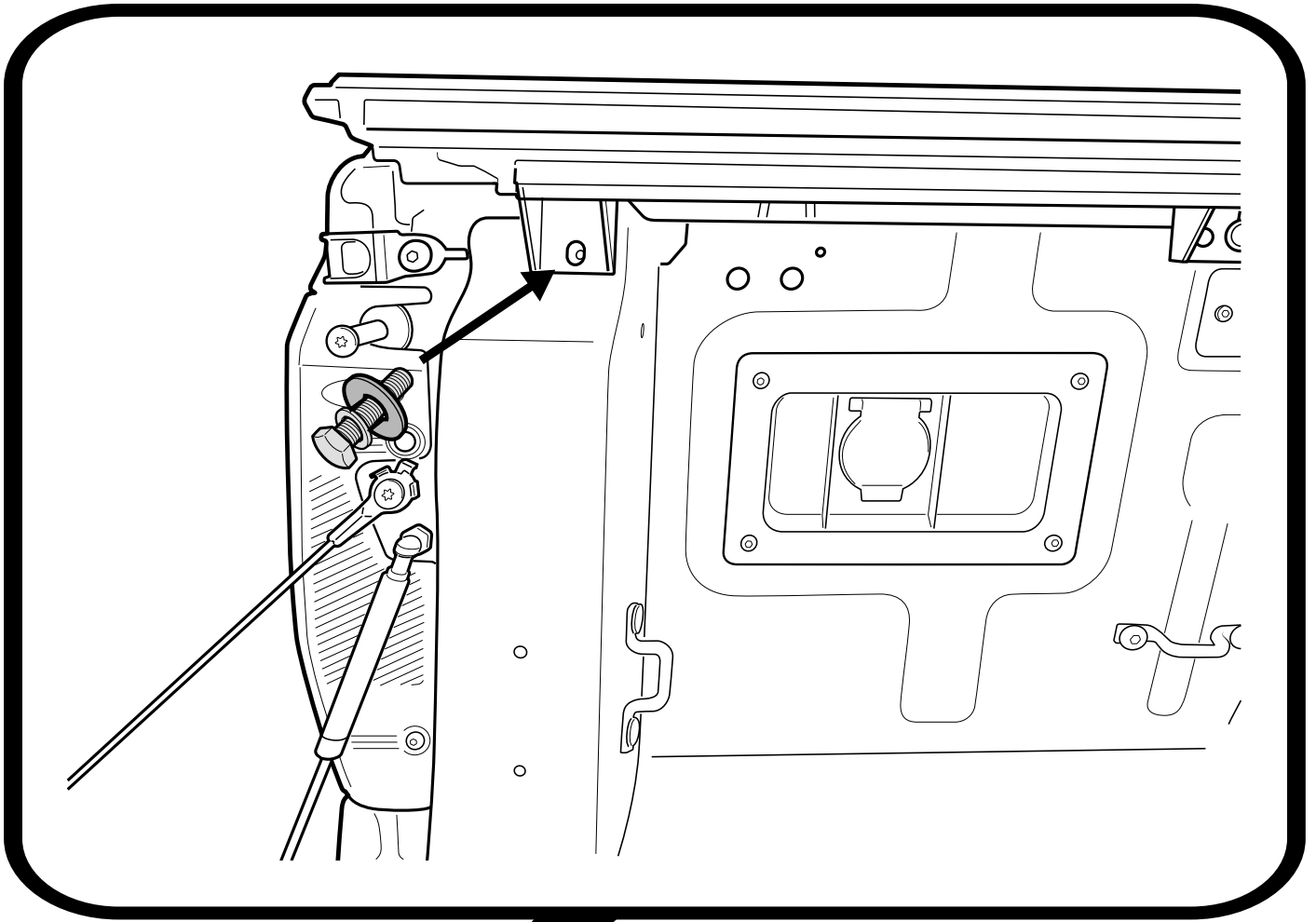

Position clamp behind the inner top lip of the bed rail and the center elongated hole of the side rail mounting brackets. Repeat to other side.

Ensure the M8 nut is in the indicated slot of the clamp

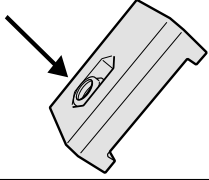

Fasten clamp loosely into position using M8 washer, M8 spring washer and M8 x 35mm bolt.

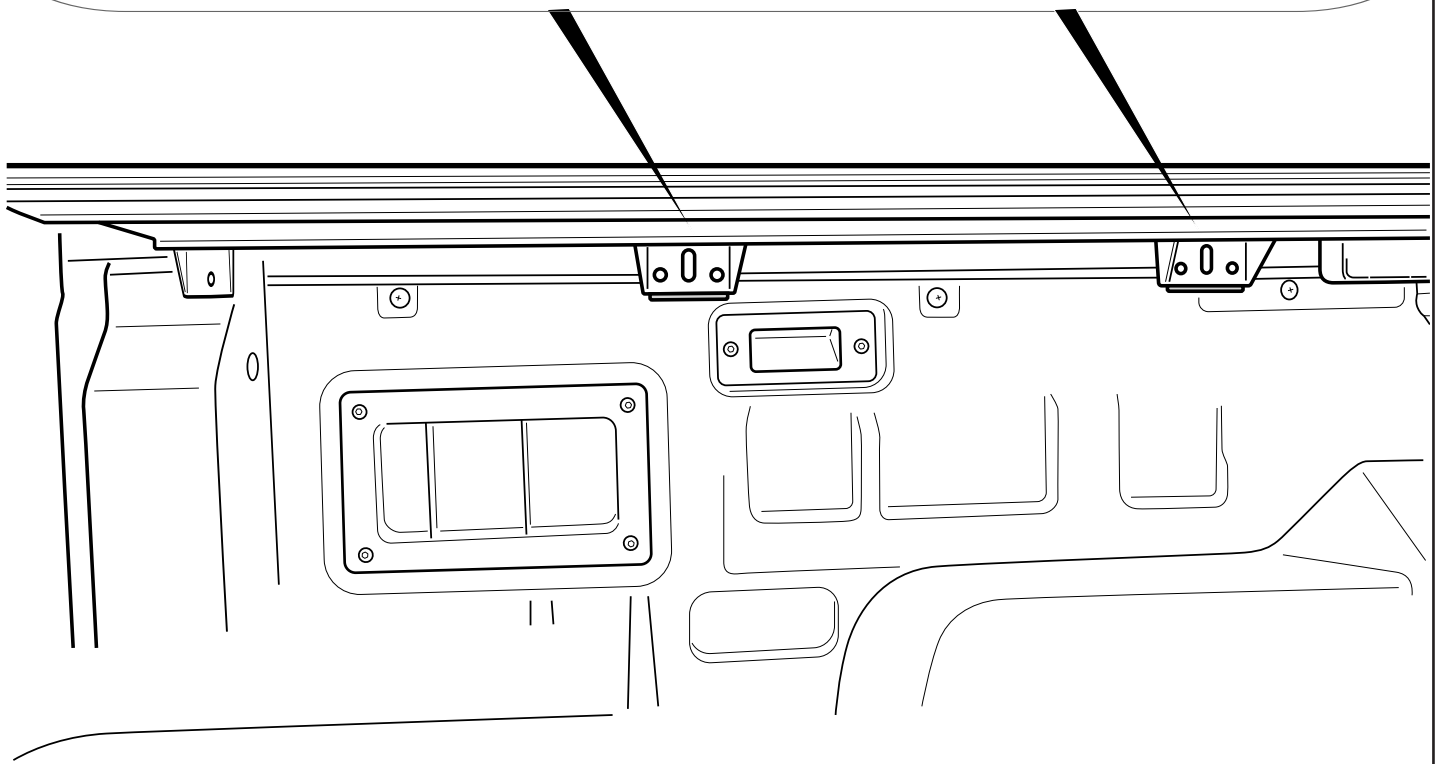
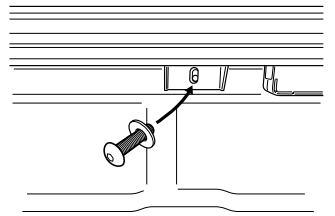

Please follow the steps in order starting with point 1.

1. With assistance apply down pressure to the side rail surface. Keeping that position, now fasten the M6 x 25mm hex bolt to 8Nm torque.
2. Making sure the black spacer is still in-line with the bottom of side rails clamp bracket, push clamps up as far as possible into the inner rail of the tub and fasten bolts to 10Nm torque.
3. Making sure the black spacer is still in-line with the bottom of side rails clamp bracket, push clamps up as far as possible into the inner rail of the tub and fasten bolts to 10Nm torque.

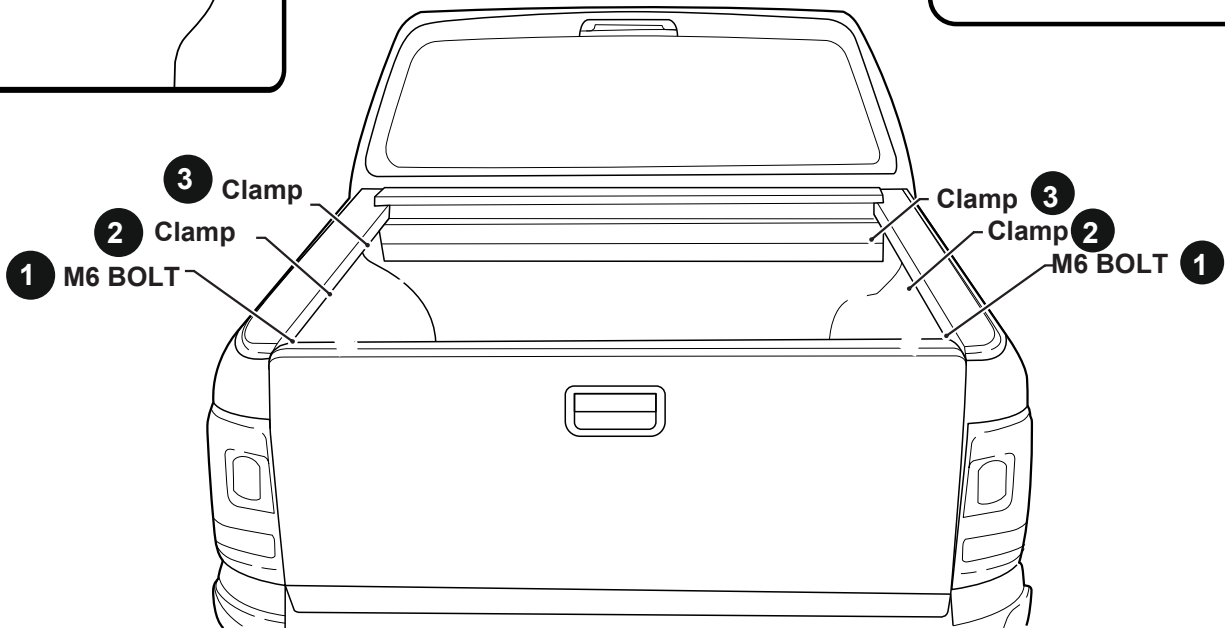
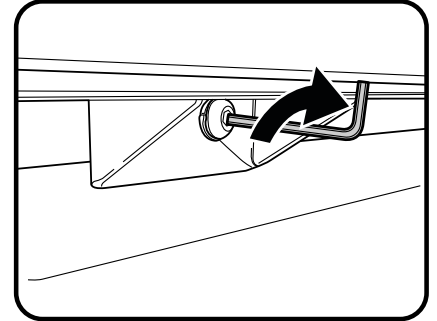
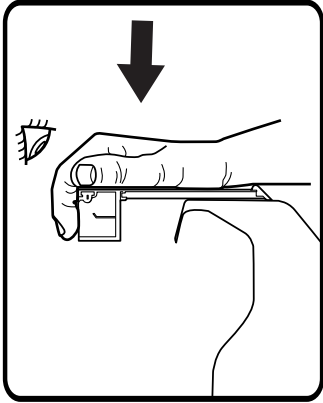

Side rail to sit level, side rail seal will sit below the top of the tailgate in the closed position.

If required M6 hex bolt can be loosened to push the side rails further down or lift up. Fasten bolt to 8Nm torque.

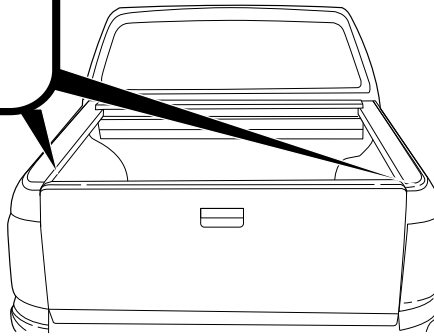
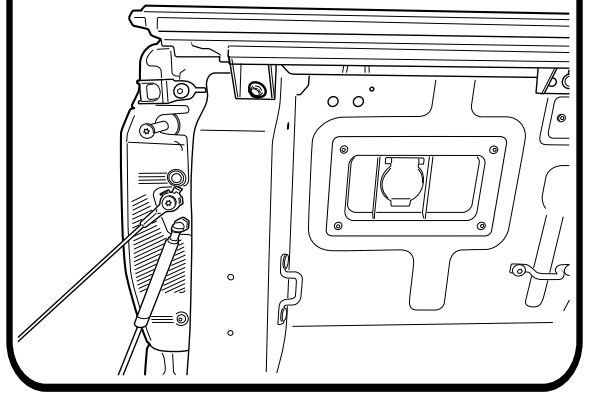
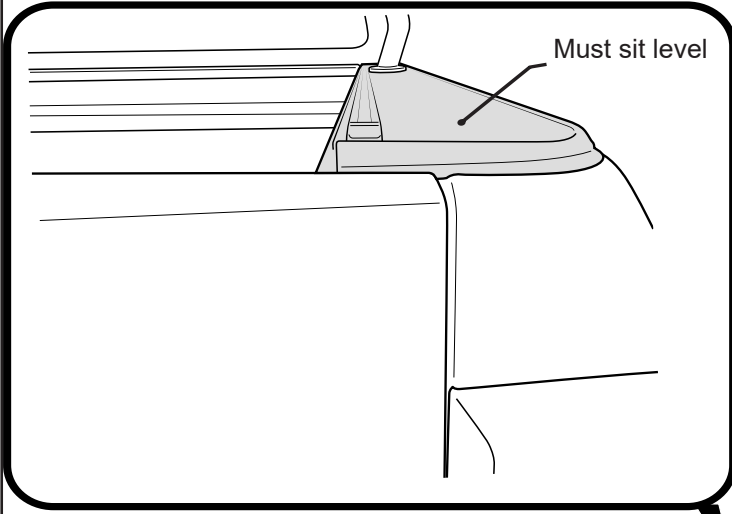

Siderail seal will sit tucked in at indicated position of the the tailgate plastic trim.

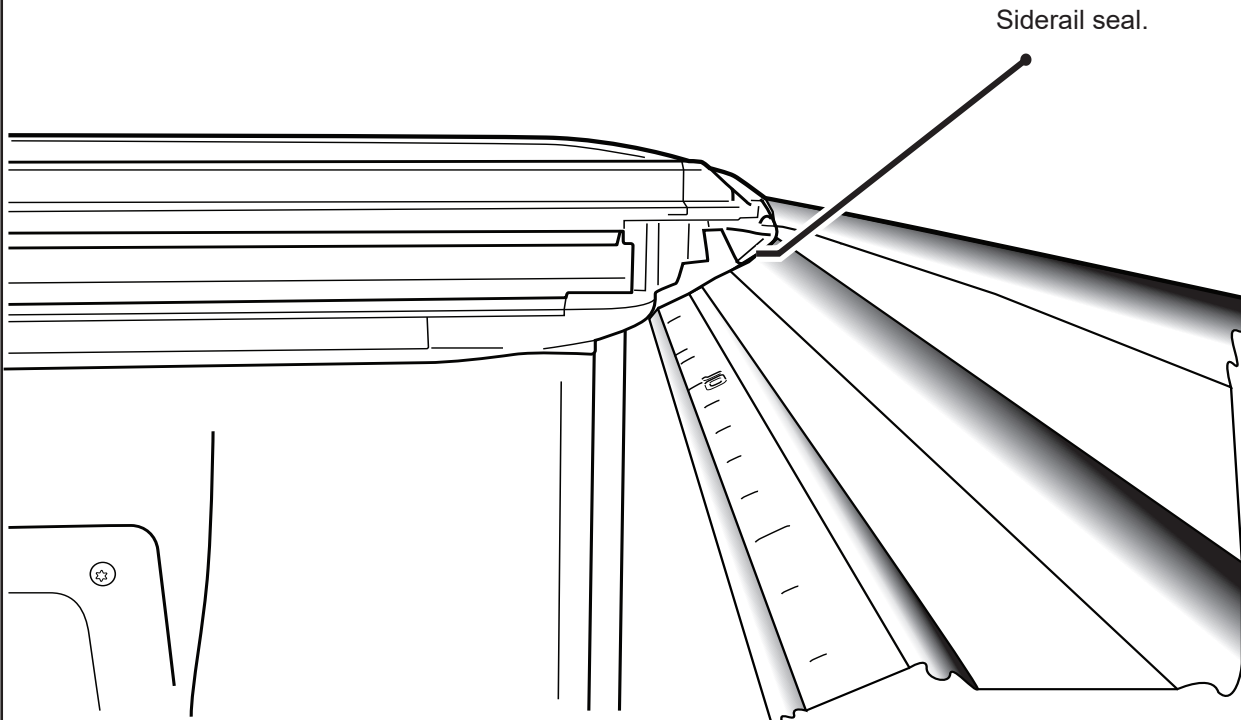

Install front drain pipes through pre-drilled holes of the canister. (RHS/LHS)



Note: With care push tube in.
Taking care pull the tube back
so it seals correctly against
the front panel of the tub.

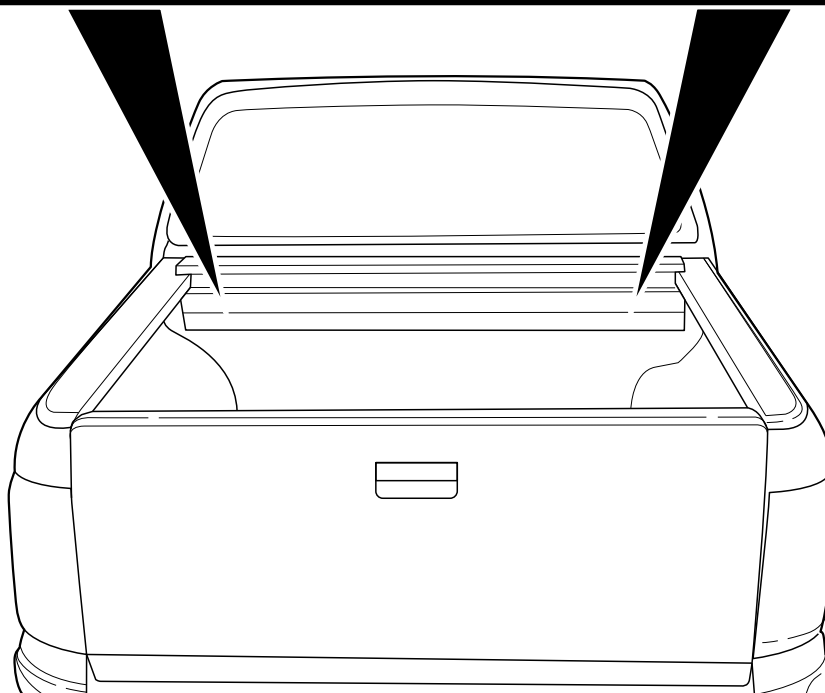
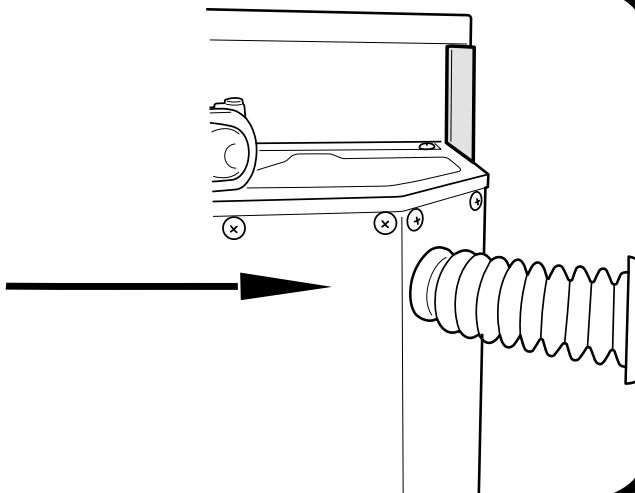
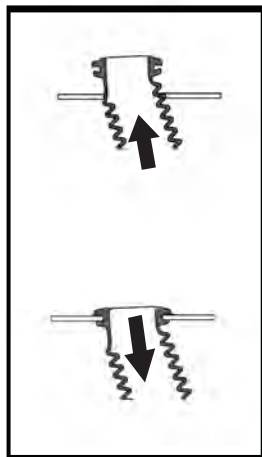

Fasten the bolts indicated.

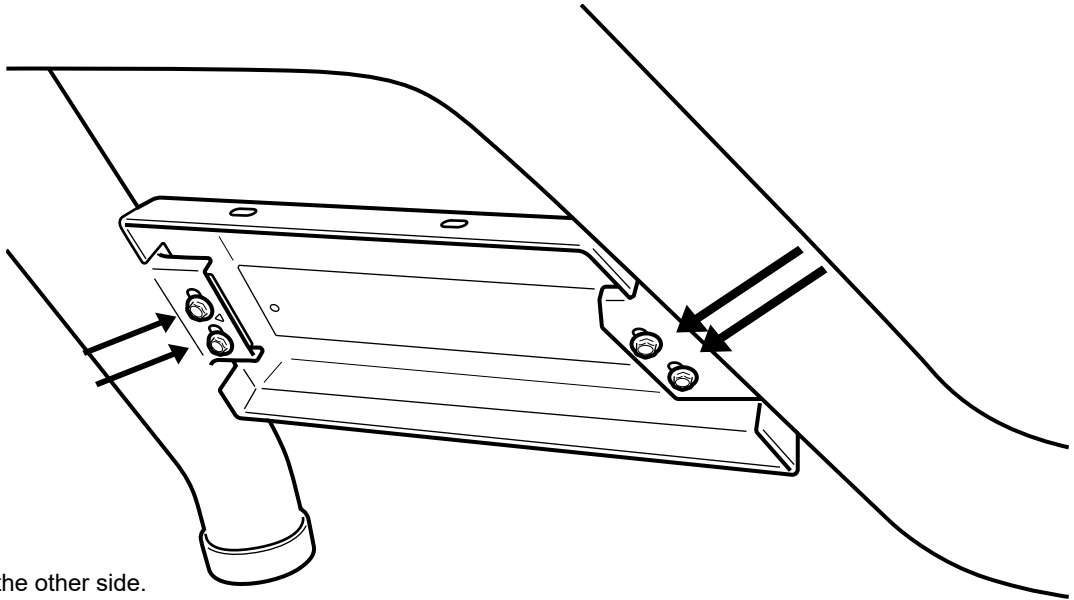

Repeat above steps to the other side.

Align back cover for side plate as indicated.

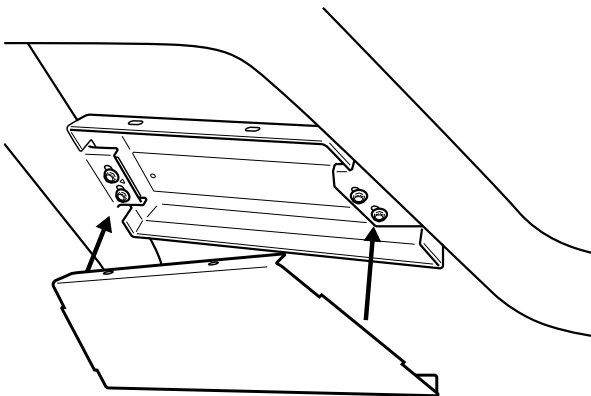

Fasten into position using M6x20 Allen head bolt through M6 spring washer and M6 large washer.

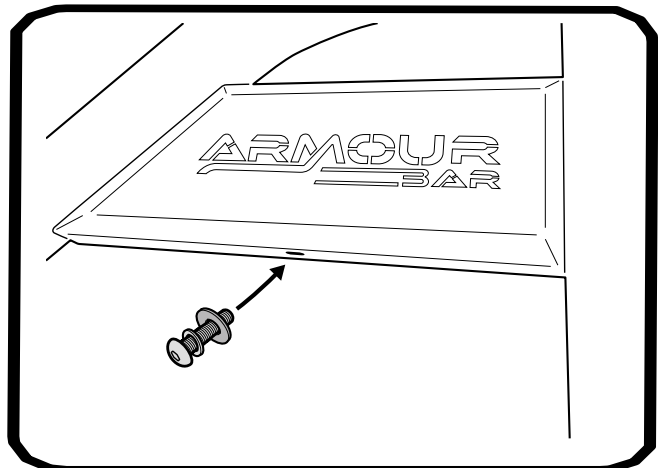
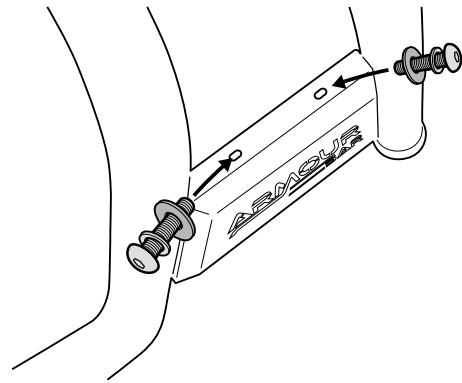

Repeat above steps to the other side. Re-connect the brake light loom to the vehicle.

- a. Connect Battery loom S2.75 to Receiver loom.
- b. **Carefully** connect CI-Loom-short to Receiver loom.



Align connectors carefully to avoid pushing pins out.

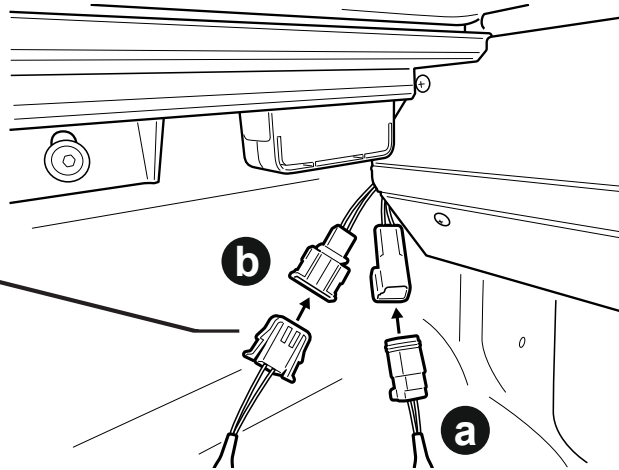

NOTE: 1. To wear in the Roll R Cover please fully open & close the cover approximately 15 times after install is complete.

2. Set your vehicle locking system to unlock all doors with one press of the factory remote unlock button. This setting can be found in your vehicle settings.

Operating instructions:

Press unlock on vehicle key fob to activate controller.

When vehicle is unlocked the side rail sensor buttons will be active to control.

When vehicle is locked the side rail sensor buttons will be inactive.

Using factory key fob to operate:

Pressing unlock twice on the factory key fob within 4 seconds, will activate the roll r cover to open.

Pressing lock twice on the factory key fob within 4 seconds, will activate the roll r cover to close.



Vehicle proximity:

Tapping the proximity twice to open or lock the car door will act exactly the same way as the key fob being pressed twice.

Touch & let go to open, touch & let go again to pause.

Touch & let go to close, touch & let go again to pause.

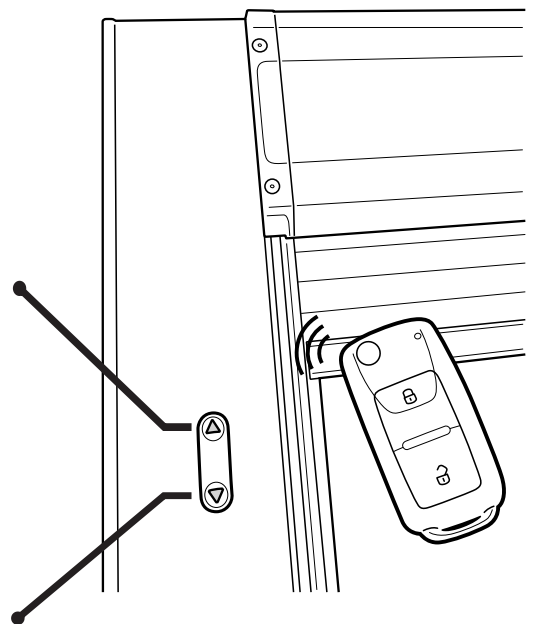



NOTE: You must service the unit before hand over, please scan the QR code to see how to service.

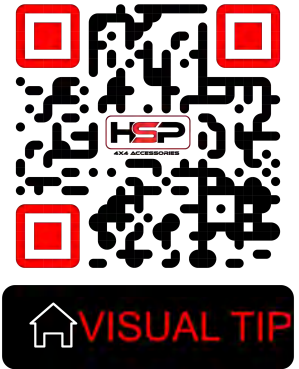

Trouble shooting visual tips:

side rail Parallel test

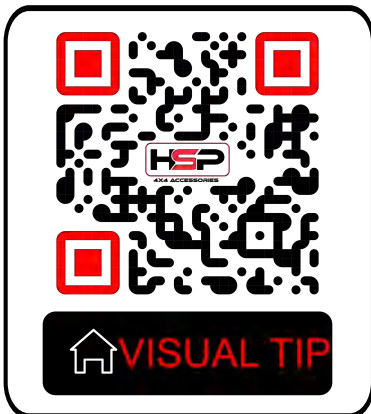

Ampage test and servicing

