



# INSTALLATION INSTRUCTIONS

## LOAD RACK ACCESSORY BAR



**INSTALLATION TIME:**90minutes (Approximately)

<b>IMPORTANT</b>	<ul style="list-style-type: none"> <li>• Do not exceed load limit indicated by manufacture.</li> <li>• If contact with volatile chemicals occur, clean bars with mild detergent and water solution</li> </ul>		
<b>Care Instructions</b>	<ul style="list-style-type: none"> <li>• Read Instructions fully before commencing installation.</li> <li>• Clean with a mild detergent and water solution</li> <li>• Do not use abrasive cleaners or solvents</li> <li>• Refer to manufactures instructions applicable to power drill.</li> <li>• Protect surface against scratches during installation process.</li> </ul>		
<b>Maintenance</b>	Refer to Maintenance instructions.		
<b>Tools Required</b>	<table style="width: 100%; border: none;"> <tr> <td style="vertical-align: top;"> <ul style="list-style-type: none"> <li>• Pen / Marker</li> <li>• Soapy water solution</li> <li>• Allen Key set</li> <li>• Screw driver</li> <li>• Trim Removal Tool</li> </ul> </td> <td style="vertical-align: top;"> <ul style="list-style-type: none"> <li>• Scissors &amp; Knife</li> <li>• Spanner &amp; Socket</li> <li>• Tape measure</li> </ul> </td> </tr> </table>	<ul style="list-style-type: none"> <li>• Pen / Marker</li> <li>• Soapy water solution</li> <li>• Allen Key set</li> <li>• Screw driver</li> <li>• Trim Removal Tool</li> </ul>	<ul style="list-style-type: none"> <li>• Scissors &amp; Knife</li> <li>• Spanner &amp; Socket</li> <li>• Tape measure</li> </ul>
<ul style="list-style-type: none"> <li>• Pen / Marker</li> <li>• Soapy water solution</li> <li>• Allen Key set</li> <li>• Screw driver</li> <li>• Trim Removal Tool</li> </ul>	<ul style="list-style-type: none"> <li>• Scissors &amp; Knife</li> <li>• Spanner &amp; Socket</li> <li>• Tape measure</li> </ul>		

**PERSONAL PROTECTIVE EQUIPMENT:**



Rubber Gloves



Goggles



Hearing Protection

# BOX CONTENTS

PART NO. LR-SF-007

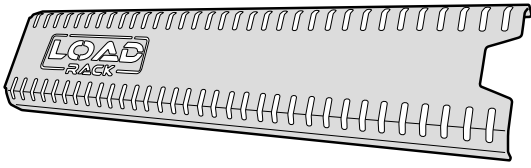

Qty - 2

PART NO. LR-SF-008

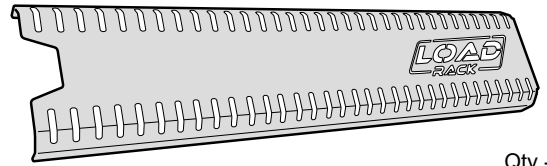

Qty - 2



M6 SPRING  
WASHER

Qty - 16



M6x16mm  
SOCKET  
HEAD BOLT

Qty - 16

LR-SM-001



CHANNEL NUT

Qty - 4



S5 ALLEN KEY

Qty - 1



M6 NUT

Qty - 16

Unfasten the indicated M6x16mm socket head bolts, this applies to both the front and rear ladder racks.  
Retain all hardware.

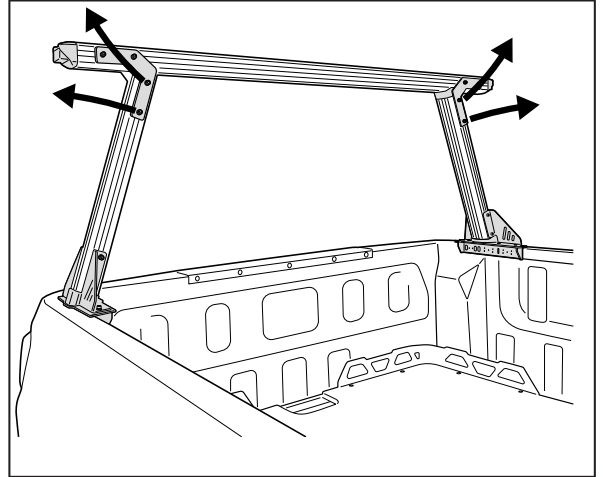
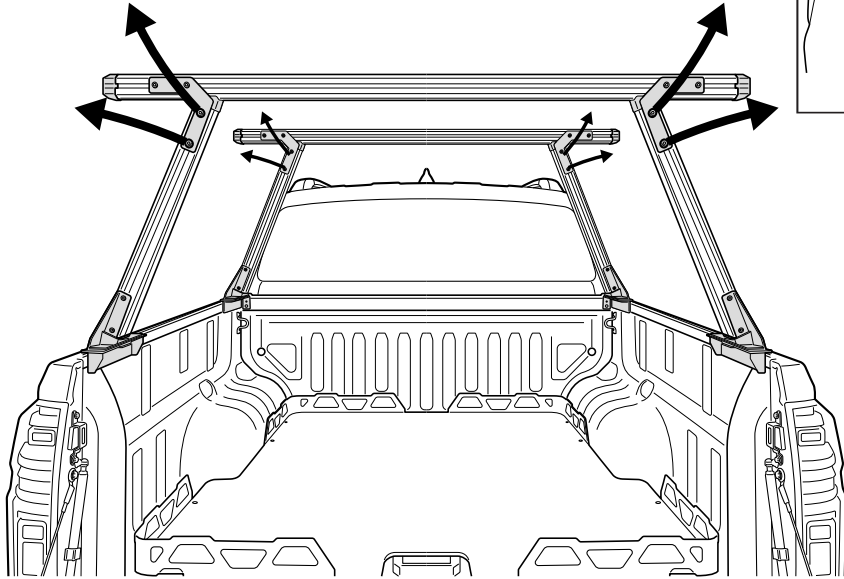

Remove both front and rear cross bars of the ladder racks.

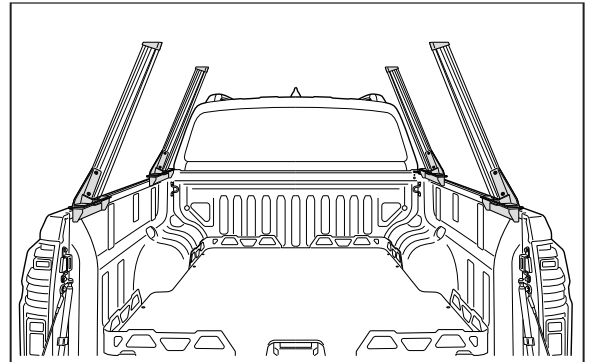
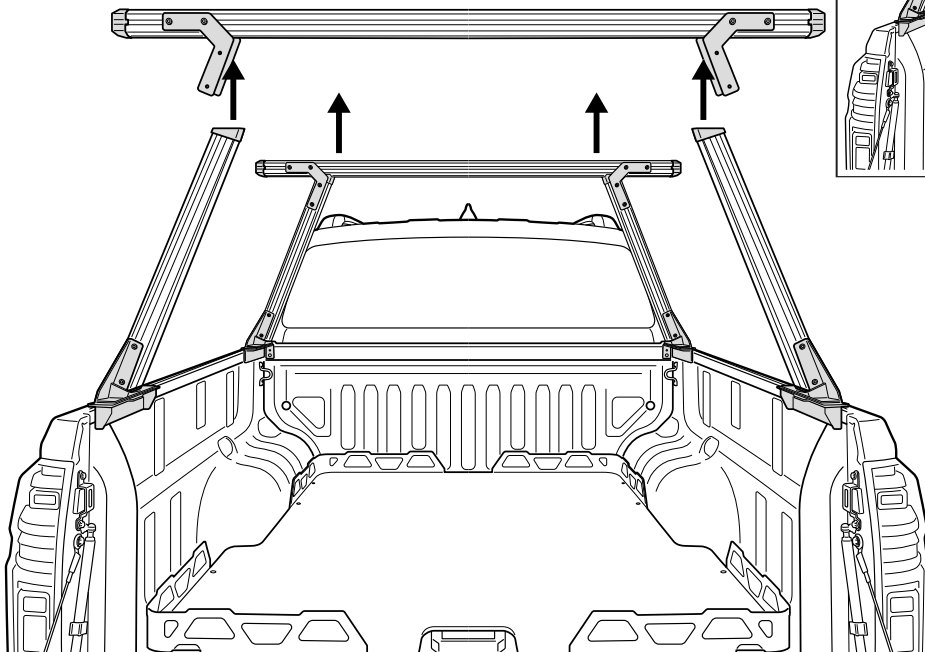

Remove indicated upright top caps and retain.

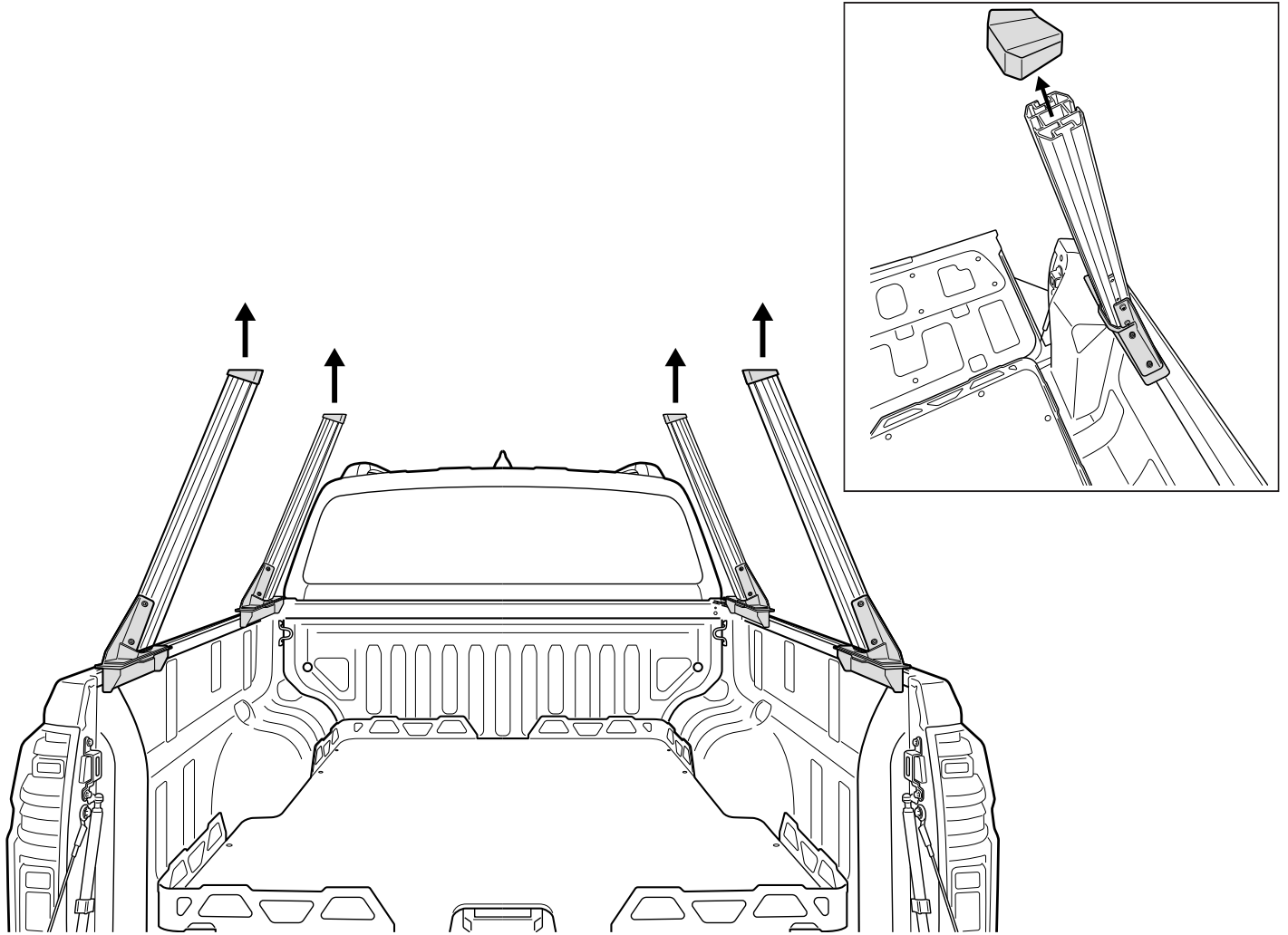

Insert LR-SM-001 channel nut to the indicated slots of the extrusion.  
Repeat to the other side.

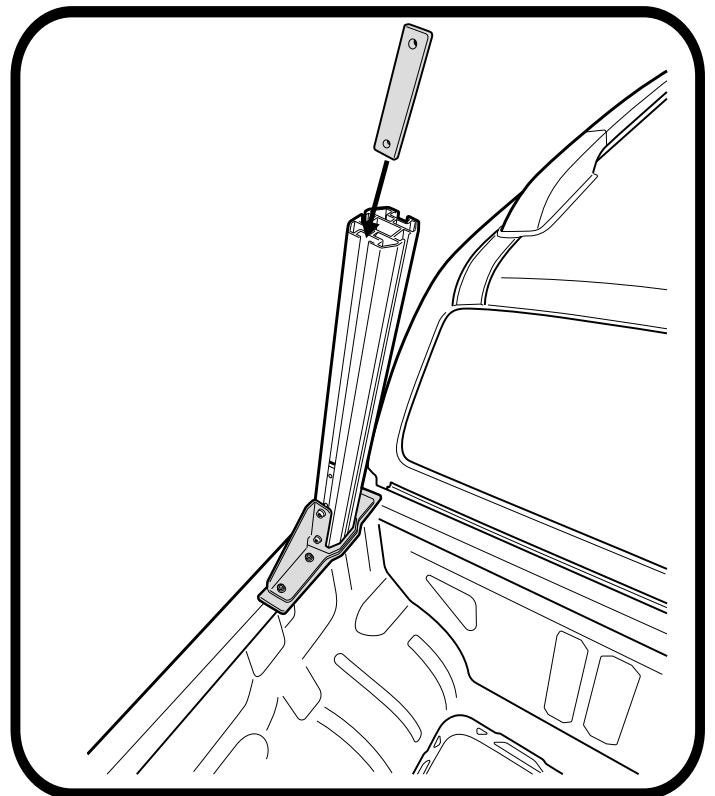
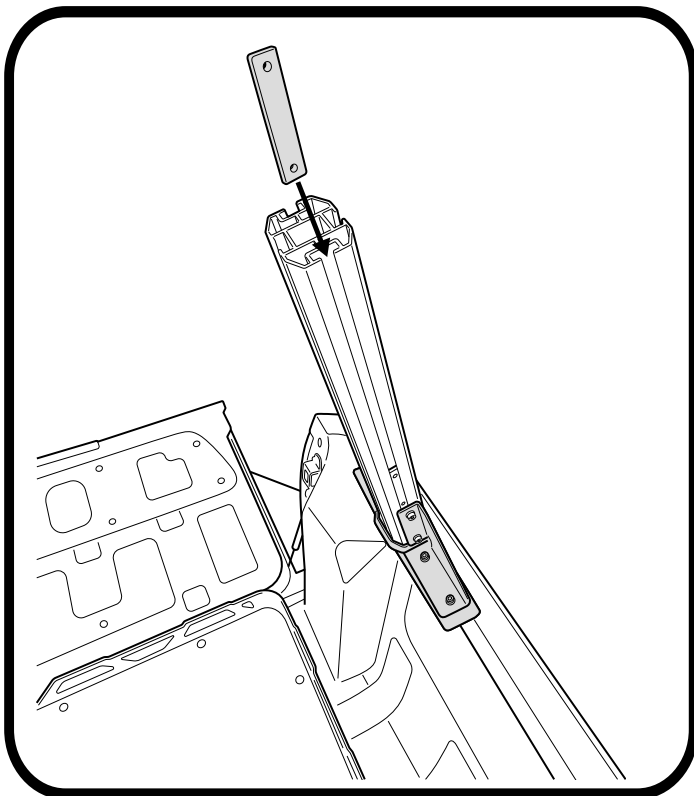

Place the previously removed top caps back into their designated positions, ensuring they are oriented in the same direction as before.

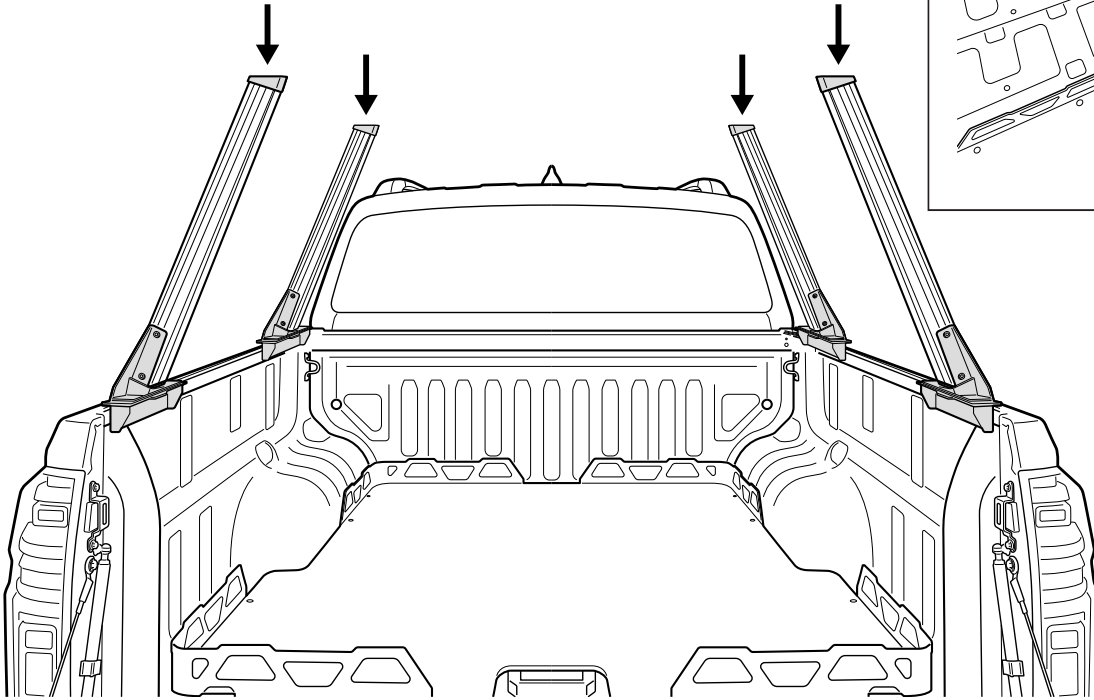
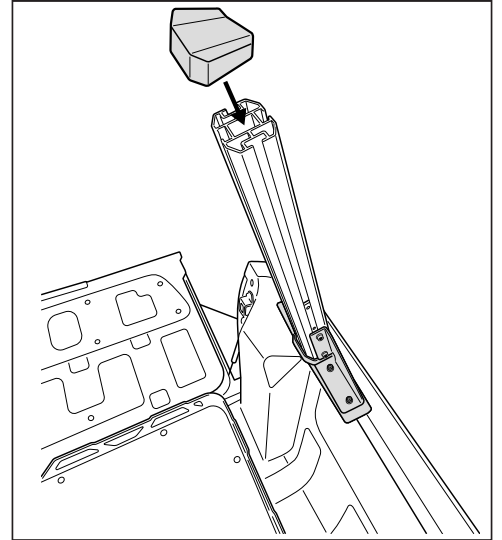

Reinstall the front and rear cross bars of the ladder racks onto the ladder rack uprights. Secure them in place by using the M6x16mm socket head bolts that were kept aside.

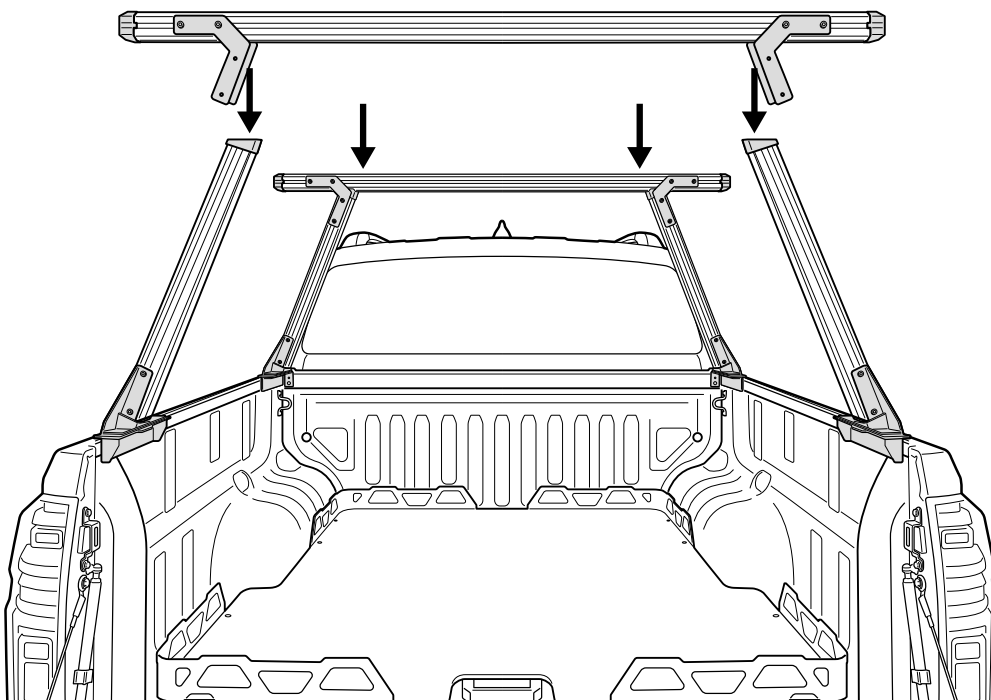

Align LR-SF-007 with the LR-SM-001 (channel nut) and loosely secure it in place using M6x16mm socket head bolts and M6 spring washer.

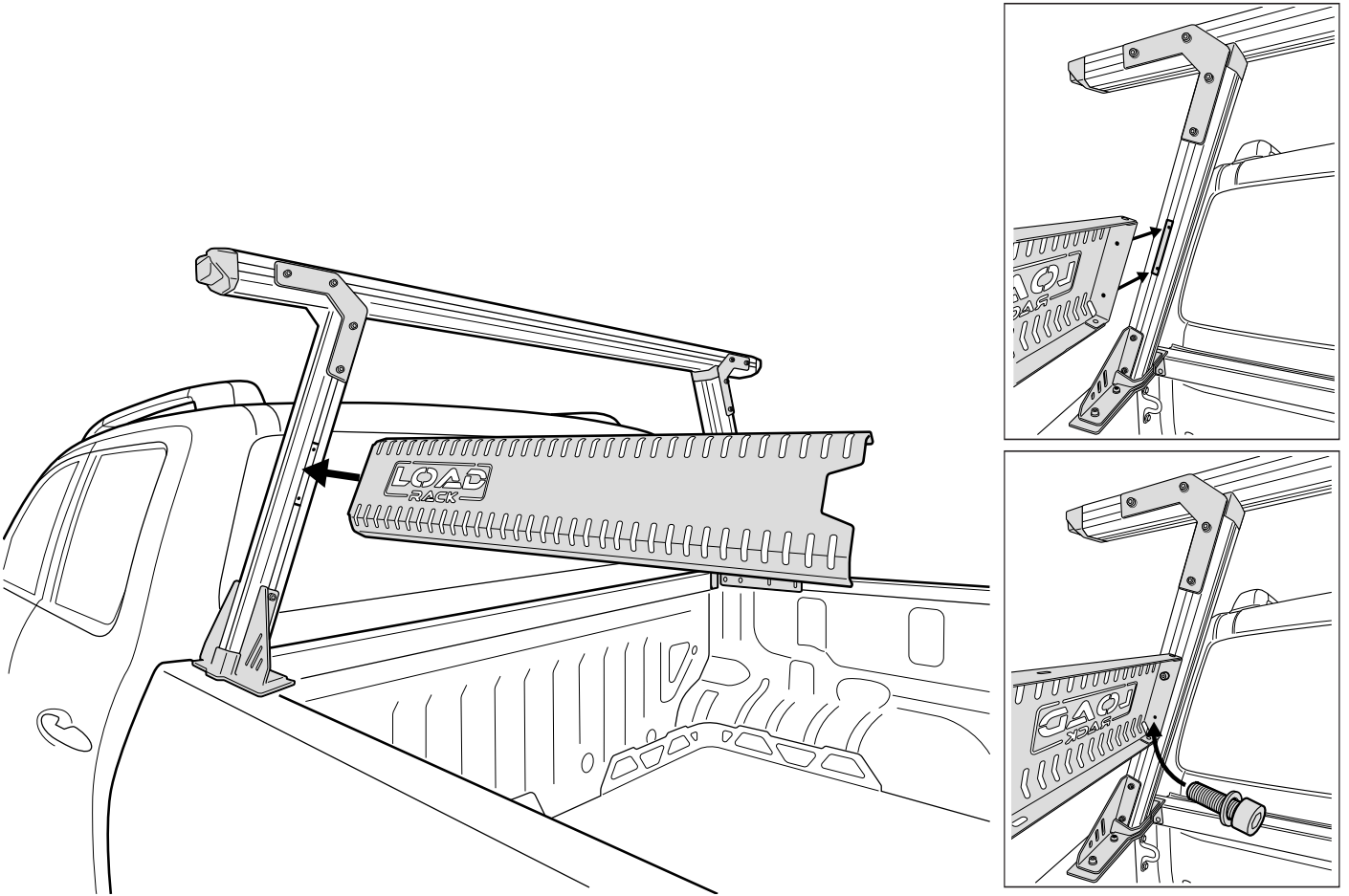

Align LR-SF-008 with the LR-SM-001 (channel nut) and loosely secure it in place using M6x16mm socket head bolts and M6 spring washer.

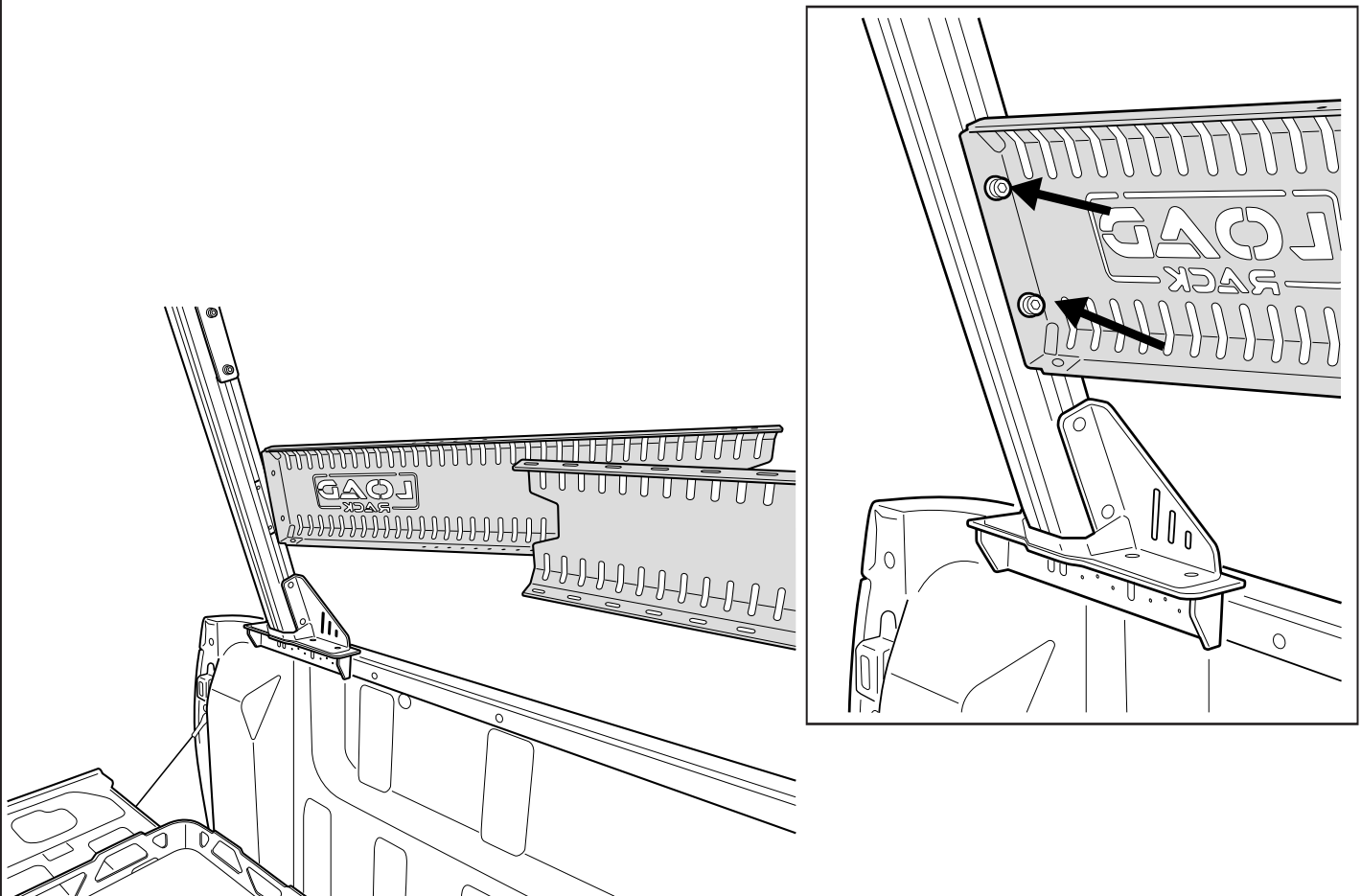

In the center, overlap LR-SF-008 with LR-SF-007. Insert M6x16mm socket head bolts and M6 spring washers through the aligned holes of LR-SF-008 and LR-SF-007, selecting two locations on top and two on the bottom. Loosely secure them in place using M6 nuts..

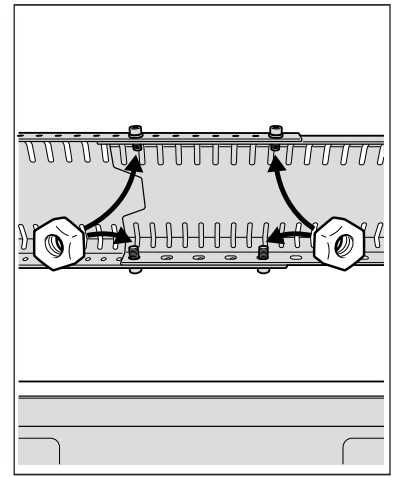
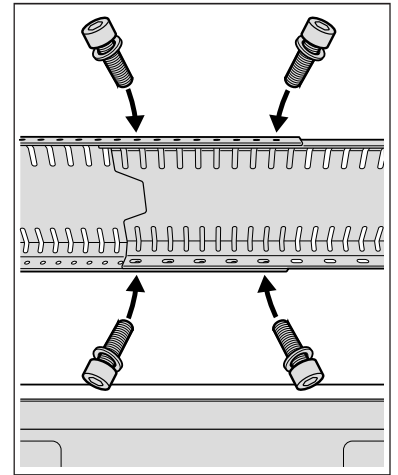
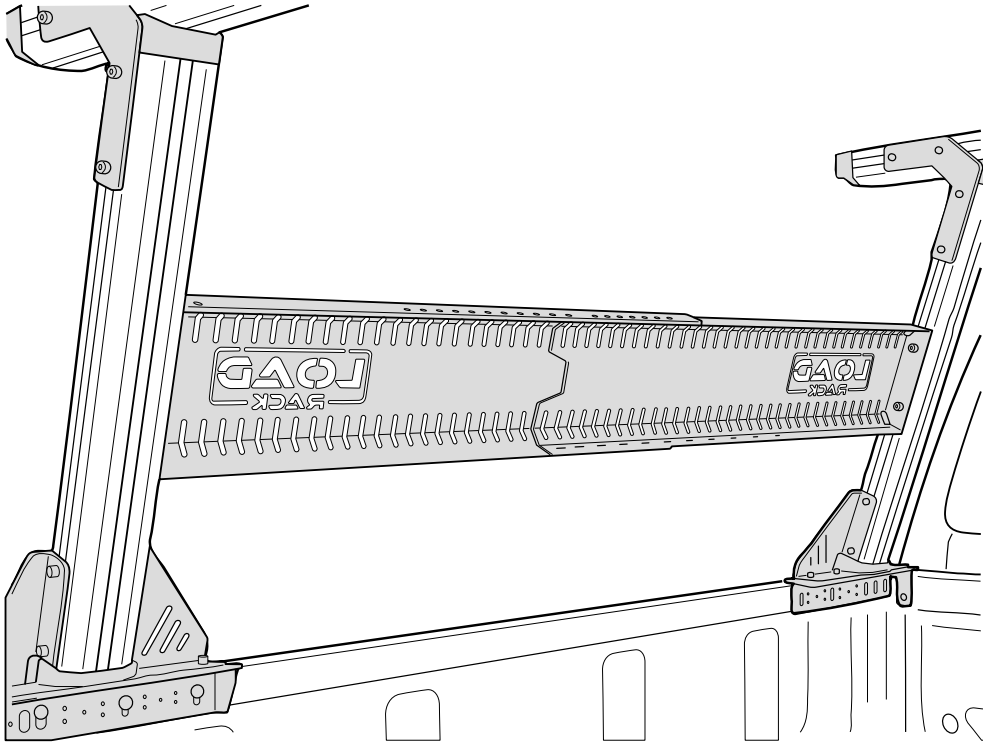

From the cross bar brace bracket, measure a distance of 100mm downwards to LR-SF-007 and make a mark at that location.

Proceed to securely fasten the M6 socket head bolts now.

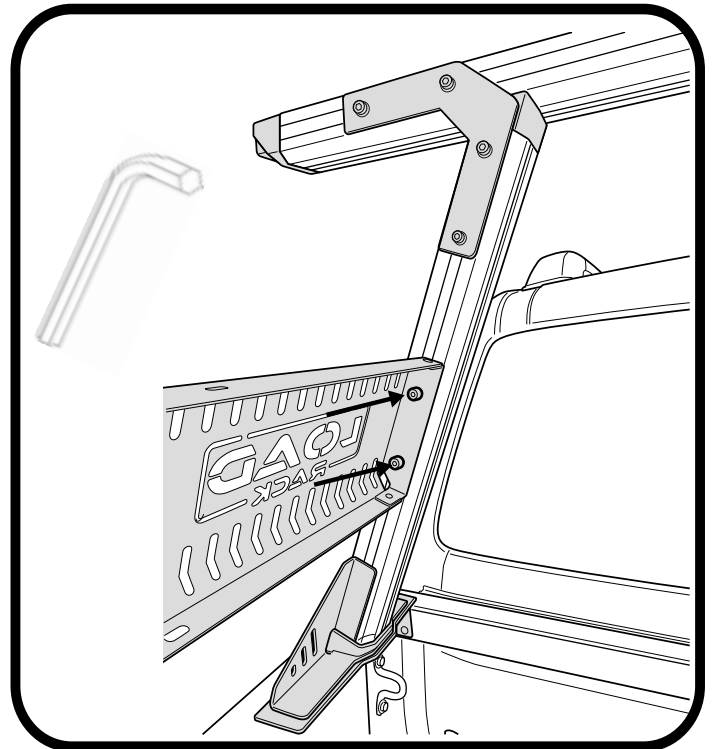
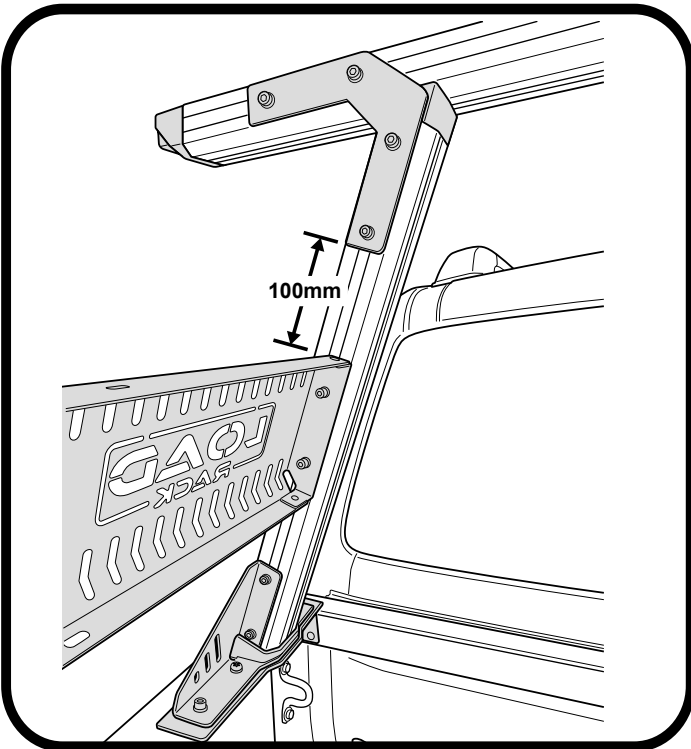

The measurements provided are intended as a general guide, but you are free to adjust them according to your desired level.



From the cross bar brace bracket, measure a distance of 95mm downwards to LR-SF-008 and make a mark at that location. Then proceed to securely fasten the M6 socket head bolts now.

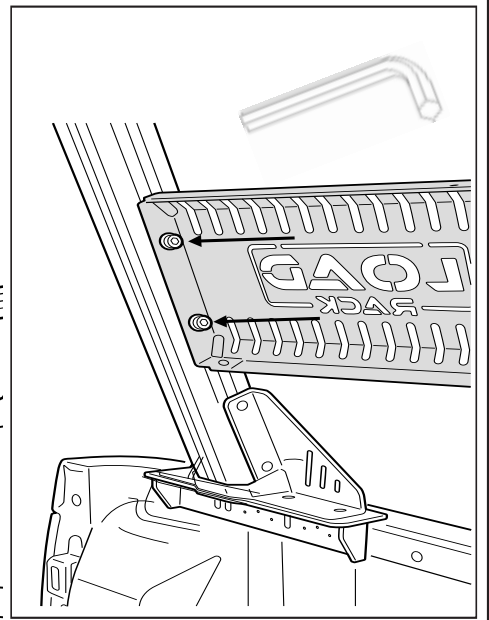
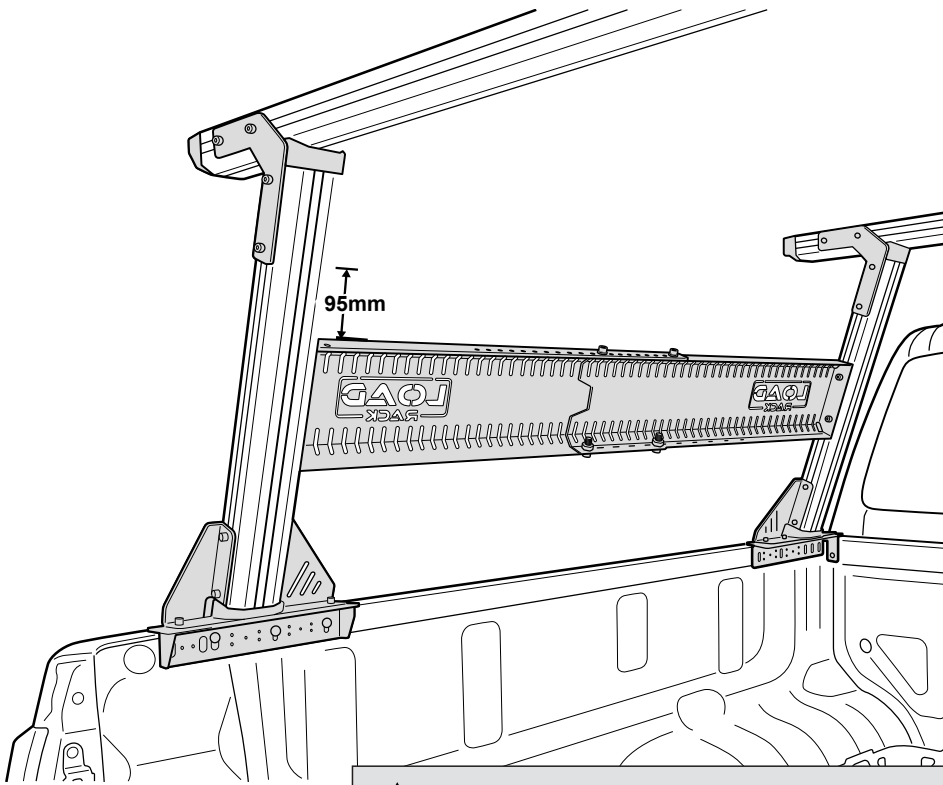

⚠ The measurements provided are intended as a general guide, but you are free to adjust them according to your desired level. ⚠

Ensure a secure fastening by firmly tightening the designated nuts and bolts.

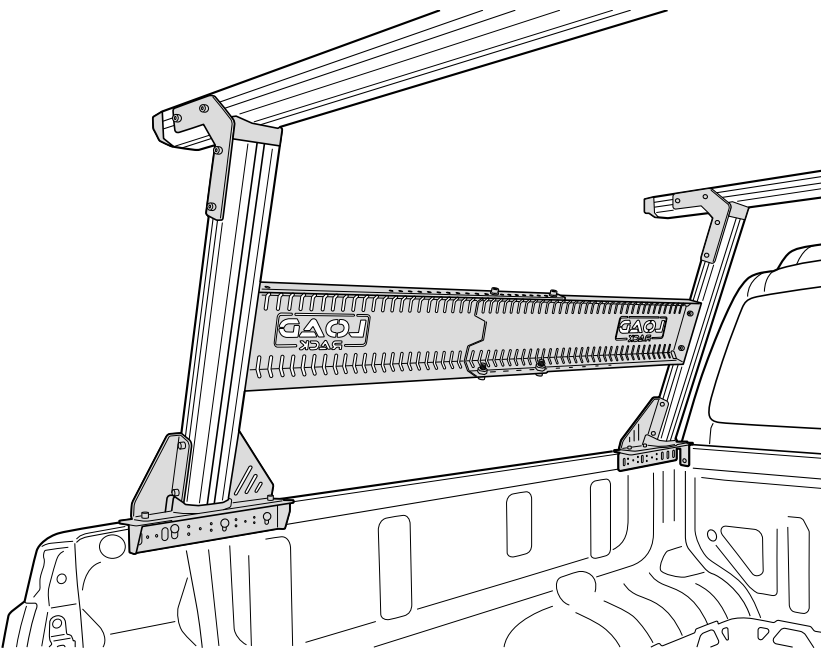
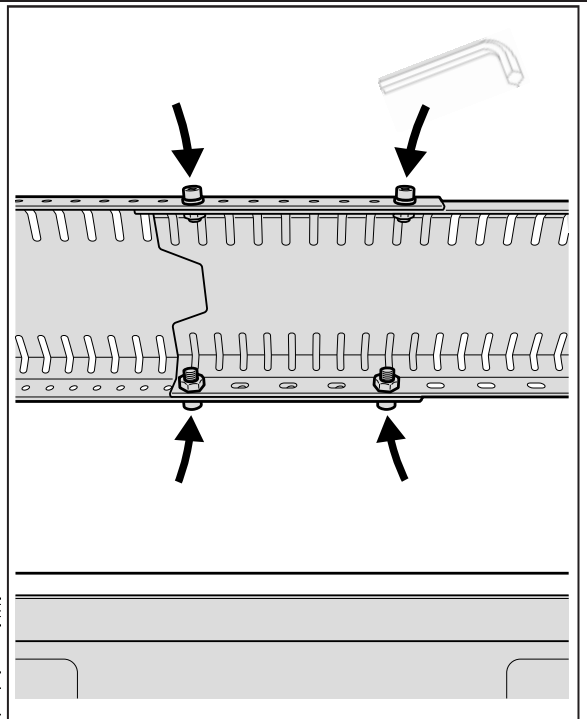



Where required, repeat the above steps to the other side.

