



# INSTALLATION INSTRUCTIONS

**GWM UTE 2020+ with Factory extended sports bars.**



**INSTALLATION TIME:** 2 Hours (Approximately)

<b>IMPORTANT</b>	<ul style="list-style-type: none"> <li>• Do not stand/sit or rest heavy objects on Roll R Cover</li> <li>• Humans or animals are not to be under the closed cover at any given time</li> <li>• Tonneau Cover is not dust or water tight</li> <li>• If contact with volatile chemicals occur, clean Cover with mild detergent and water solution</li> </ul>			
<b>Care Instructions</b>	<ul style="list-style-type: none"> <li>• Read Instructions fully before commencing installation.</li> <li>• Clean Cover with a mild detergent and water solution</li> <li>• Do not use abrasive cleaners or solvents</li> <li>• Refer to manufactures instructions applicable to power drill.</li> <li>• Protect Tub floor against scratches during installation process.</li> </ul>			
<b>Maintenance</b>	Refer to Maintenance instructions.			
<b>Tools Required</b>	<table style="width: 100%; border: none;"> <tr> <td style="vertical-align: top;"> <ul style="list-style-type: none"> <li>• Pen / Marker</li> <li>• Centre Punch</li> <li>• Drill &amp; Drill bits</li> <li>• Caulking Gun</li> <li>• Silicon - Non Acetic</li> </ul> </td> <td style="vertical-align: top;"> <ul style="list-style-type: none"> <li>• Scissors &amp; Knife</li> <li>• Spanner &amp; Socket</li> <li>• Tape measure</li> <li>• Holesaw</li> <li>• Filing tool</li> </ul> </td> <td style="vertical-align: top;"> <ul style="list-style-type: none"> <li>• Soapy water solution</li> <li>• Allen Key set</li> <li>• Screw driver</li> <li>• Rust Inhibitor</li> <li>• Trim Removal Tool</li> </ul> </td> </tr> </table>	<ul style="list-style-type: none"> <li>• Pen / Marker</li> <li>• Centre Punch</li> <li>• Drill &amp; Drill bits</li> <li>• Caulking Gun</li> <li>• Silicon - Non Acetic</li> </ul>	<ul style="list-style-type: none"> <li>• Scissors &amp; Knife</li> <li>• Spanner &amp; Socket</li> <li>• Tape measure</li> <li>• Holesaw</li> <li>• Filing tool</li> </ul>	<ul style="list-style-type: none"> <li>• Soapy water solution</li> <li>• Allen Key set</li> <li>• Screw driver</li> <li>• Rust Inhibitor</li> <li>• Trim Removal Tool</li> </ul>
<ul style="list-style-type: none"> <li>• Pen / Marker</li> <li>• Centre Punch</li> <li>• Drill &amp; Drill bits</li> <li>• Caulking Gun</li> <li>• Silicon - Non Acetic</li> </ul>	<ul style="list-style-type: none"> <li>• Scissors &amp; Knife</li> <li>• Spanner &amp; Socket</li> <li>• Tape measure</li> <li>• Holesaw</li> <li>• Filing tool</li> </ul>	<ul style="list-style-type: none"> <li>• Soapy water solution</li> <li>• Allen Key set</li> <li>• Screw driver</li> <li>• Rust Inhibitor</li> <li>• Trim Removal Tool</li> </ul>		

**PERSONAL PROTECTIVE EQUIPMENT:**



Rubber Gloves



Goggles



Hearing Protection

# BOX CONTENTS

## LEFT & RIGHT SIDE RAIL

S2.5-DC-AE-002ps-GWM43



S2.5-DC-AE-003ds-GWM43

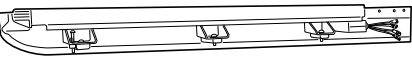

## CANISTER ASSEMBLY

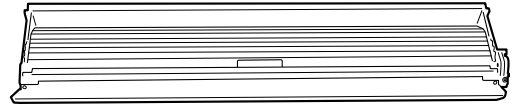

S3-DC-AF-GW4R\_LD4R-001/002

## CANISTER TOP COVER



S2.5-DC-AE-005 -GWM4

## SPECIFIC KIT GWM4R

<p>COVER END CAPS</p> <p>S2.5-DC-PI-004ps S2.5-DC-PI-004ds</p>	<p>COUNTERSUNK SCREW Qty - 4</p>	<p>50449 D-SPONGE Qty-2</p>	<p>CABLE TIE Qty x 16</p>	<p>BATTERY LOOM S2.75</p>	<p>Drainage pipe Qty - 2</p>
<p>SIDERAIL CLAMP Qty - 4</p>	<p>M8 x 35mm Qty - 4</p>	<p>M8 WASHER Qty - 4</p>	<p>M8 SPRING WASHER Qty - 4</p>	<p>M8 NUT Qty - 4</p>	<p>CL-LOOM-LONG</p>
<p>GWM-PATCH</p>	<p>GW4R-Rear Bracket-PS</p>	<p>GW4R-Rear Bracket-DS</p>	<p>Clear protective tape ( 30mm x 65mm) Qty - 2</p>	<p>Rear Drainage pipe Qty - 2</p>	

## SPORTS BAR KIT GWM43R

<p>3M PRIMER</p>	<p>SIDERAIL HOLE GASKET Qty -6</p>	<p>M6 x40mm Phillips Pan head bolt Qty - 6</p>	<p>M6 LARGE FLAT WASHER Qty - 6</p>	<p>M6 SPRING WASHER Qty - 6</p>
------------------	------------------------------------	--	-------------------------------------	---------------------------------

TRUCK BED PREPARATION

INSTALL WIRING

INSTALL TO TRUCK BED

ROLL R COVER ASSEMBLY

TEST OPERATION

FINISH

## TUB PREPARATION

If the Vehicle is fitted with a cabin guard or sports styling bar, remove from Ute Tub (truck bed).

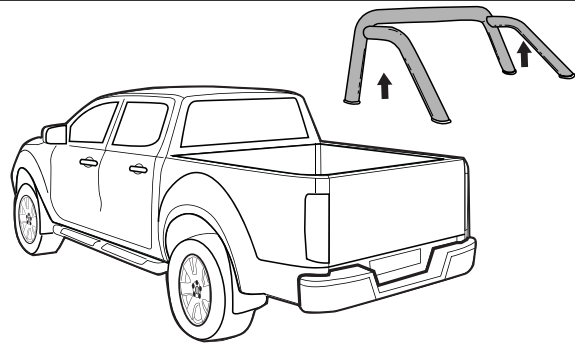

Clean are as indicated.

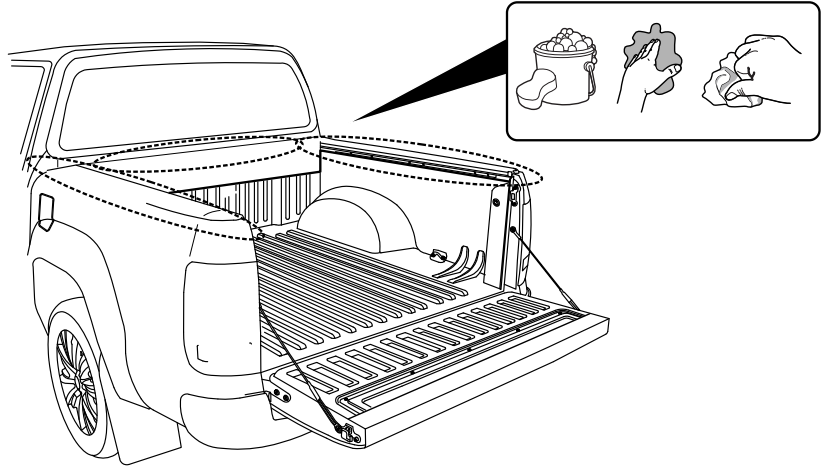

If the Vehicle is fitted with tub liner, Measure 10mm down from top of tailgate and trim tailgate liner.

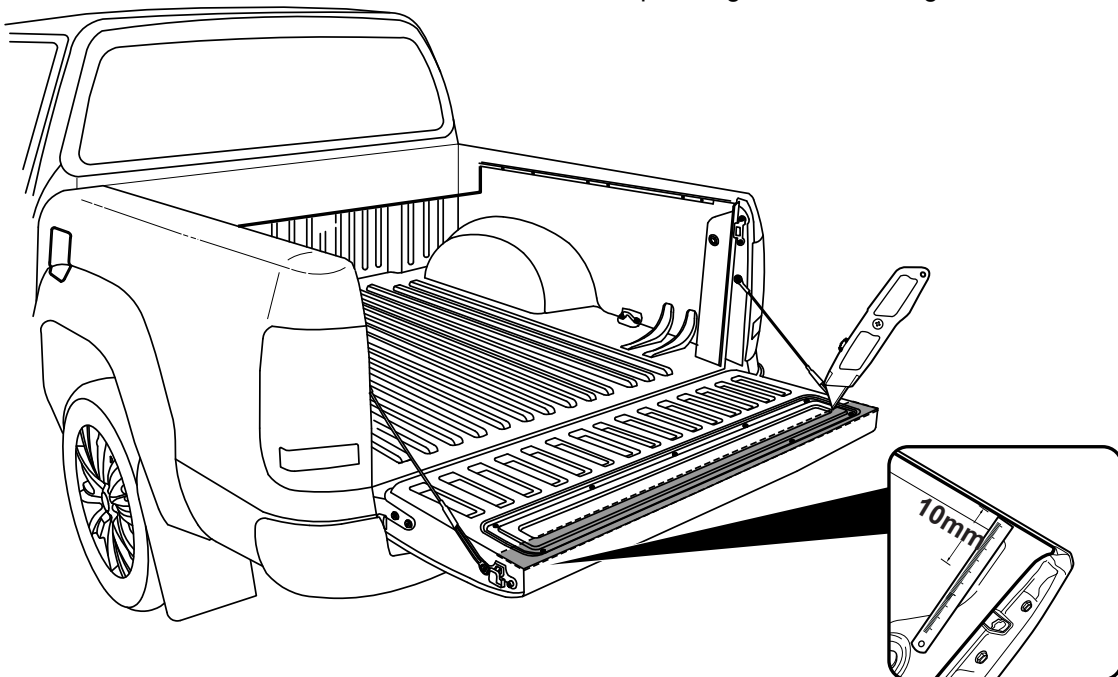

Measure down from top of assembly bar 215mm & 80 mm from inside wall of bed liner as shown. Repeat to the other side. Using a 50mm hole-saw drill the liner only as indicated.

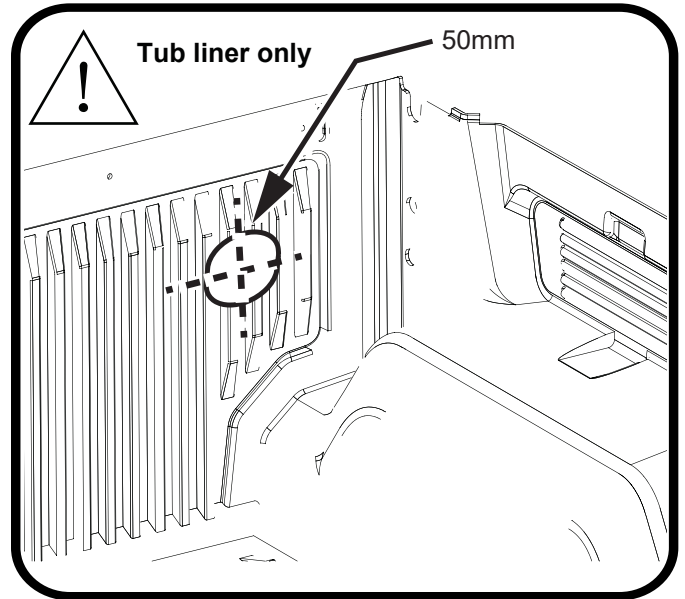
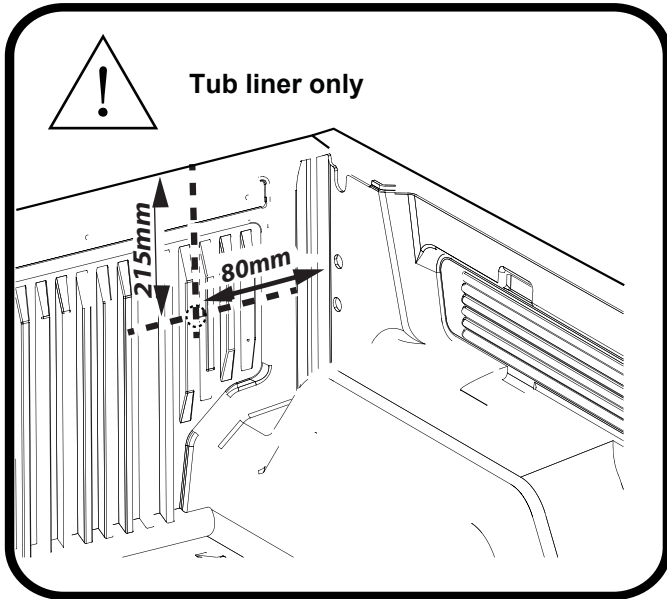
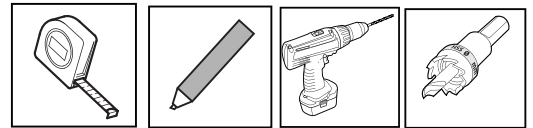

Measure down from top of headboard 215mm & 80mm from inside wall of bed as shown. ( or 80mm if measuring from the side of the top rail) Repeat to the other side. Using a 30mm hole-saw drill through tub front panel, file away any sharp edges. Apply anti rust coating. Repeat to other side.

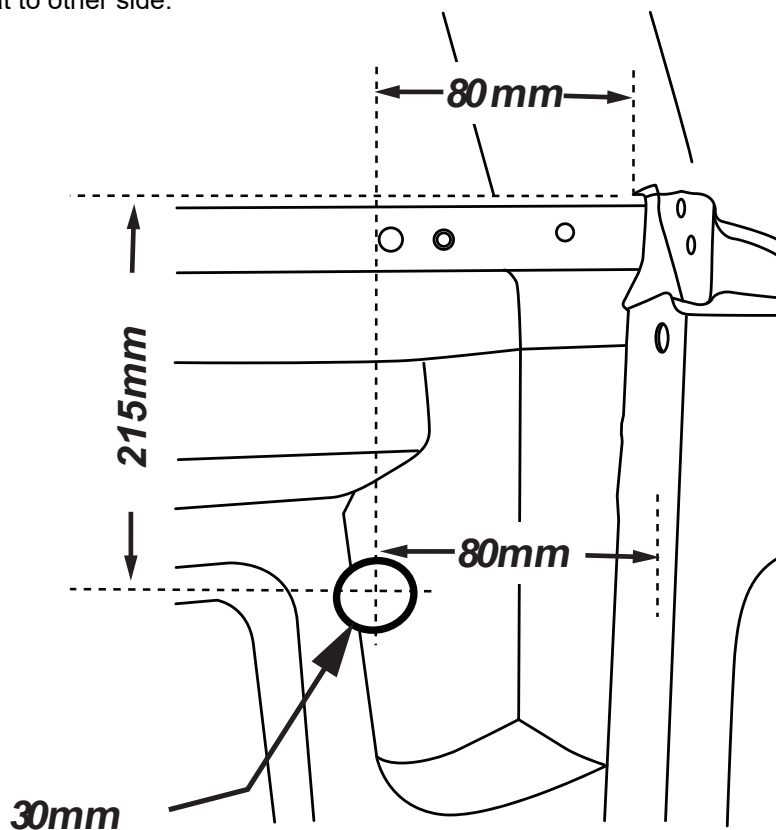
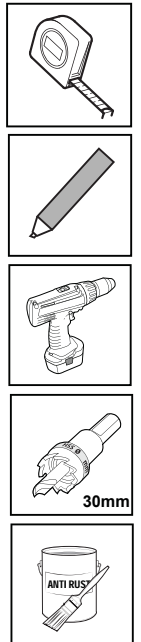

**! ATTENTION:** Do not exceed 30mm hole.

Seal any exposed gaps or holes on the front panel of the Ute bed with sealant.

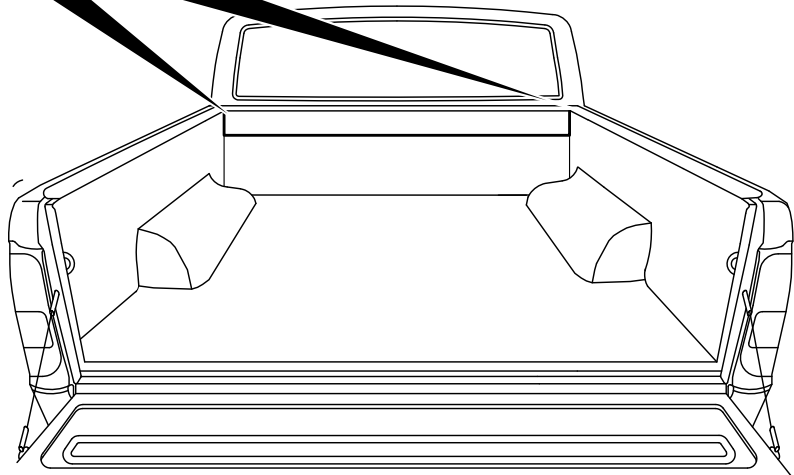
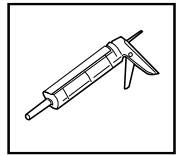
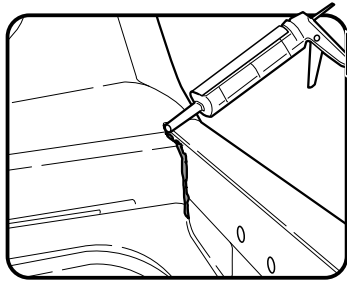

Carefully unpack the box.

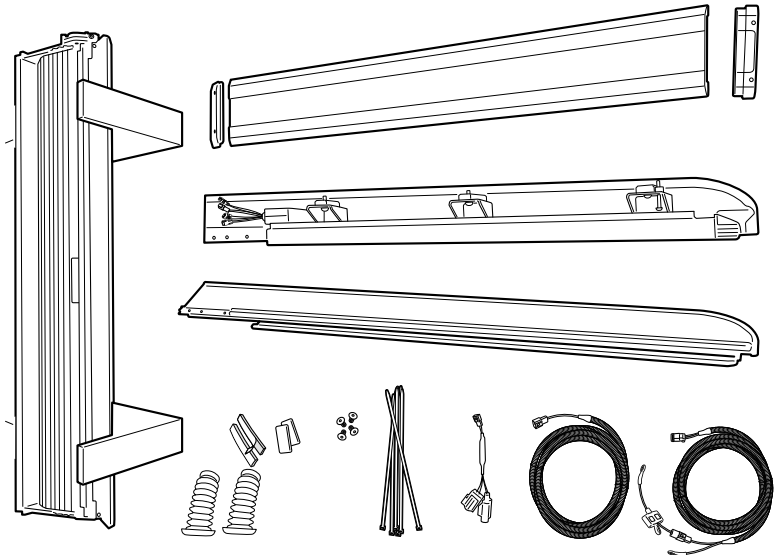
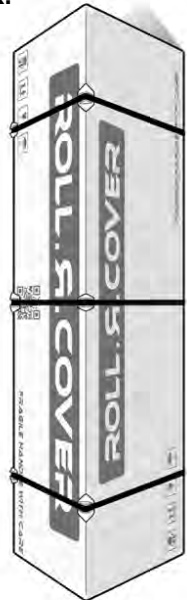

Install front drain pipes ( 55mm diameter end of hose) through pre-drilled holes on the front tub panel.



Note: With care push tube in. Taking care pull the tube back so it seals correctly against the front panel of the tub.

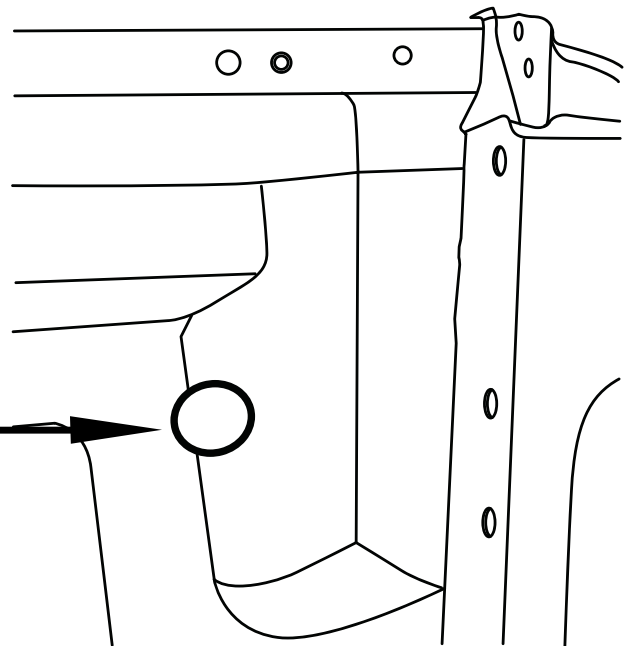
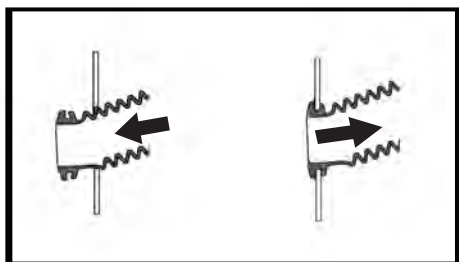

Remove and retain tail lights.

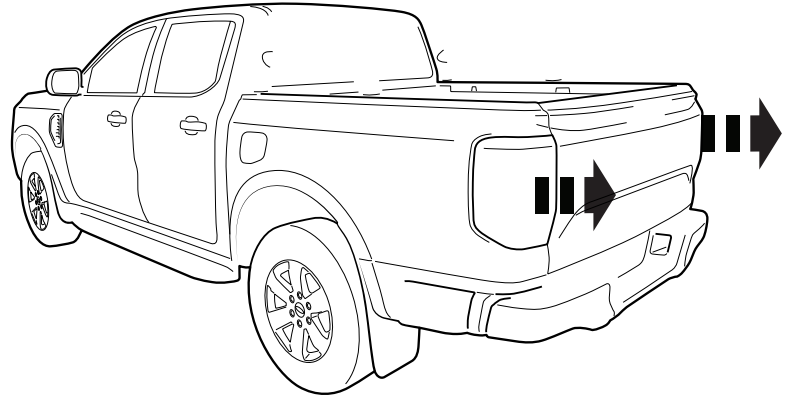

Measure 120mm towards the front of tub from the center of the indicated factory M6 bolt. Measure down 90mm from the top edge of the tub as directed and make a mark.

Use a 15mm hole-saw to drill through the tub pillar, and file away any sharp edges. Apply an anti-rust coating. Repeat the same steps on the other side.

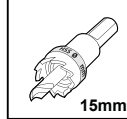
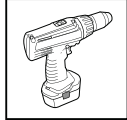
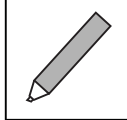
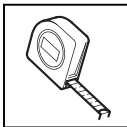

120mm

90mm

**!** **ATTENTION:** Do not exceed 15mm hole.

- a** In the specified orientation insert the rear drainage pipe into the previously drilled hole.
- b** Leaving 150mm of the pipe hanging out.
- c** Check the tail light cavity to ensure there are no obstructions to the drainage pipe. Repeat to the other side.  
Re-fit the tail lights.

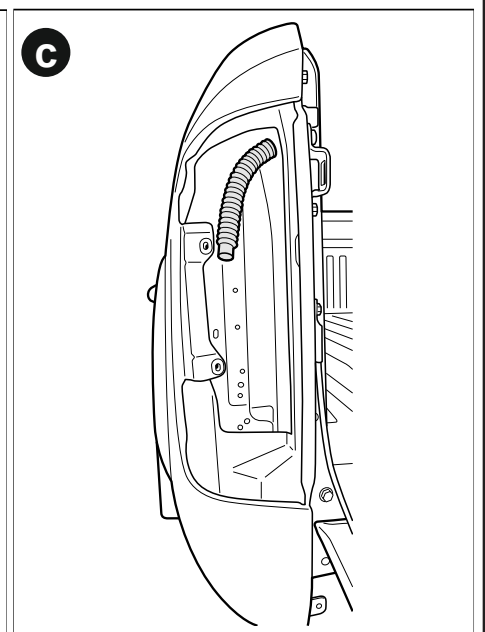
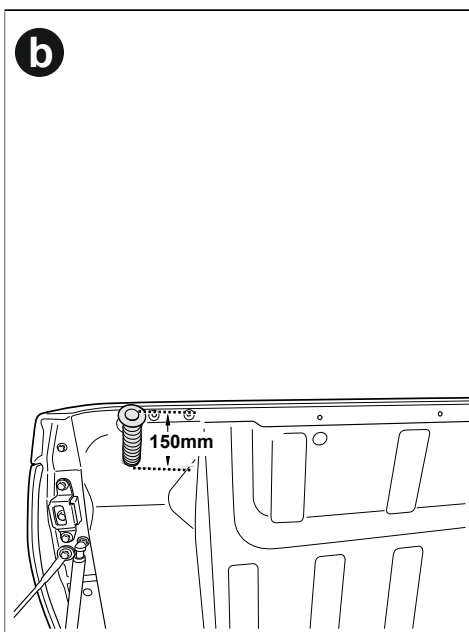
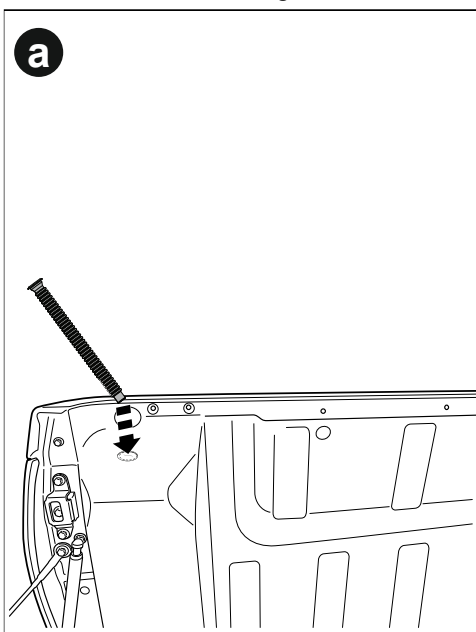

Disconnect fuse patch from battery loom S2.75.

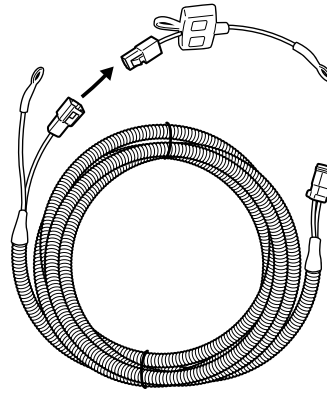

### Wiring Harness steps

**1** Feed Battery Loom S2.75 through the cavity

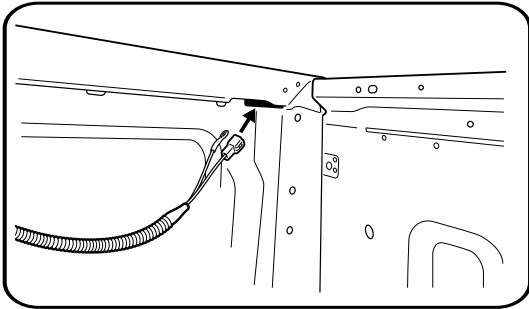

**3**

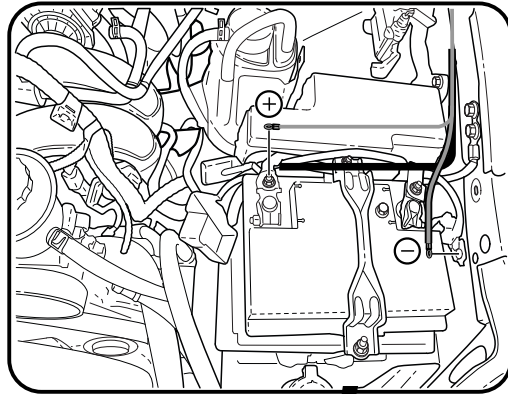

**2**

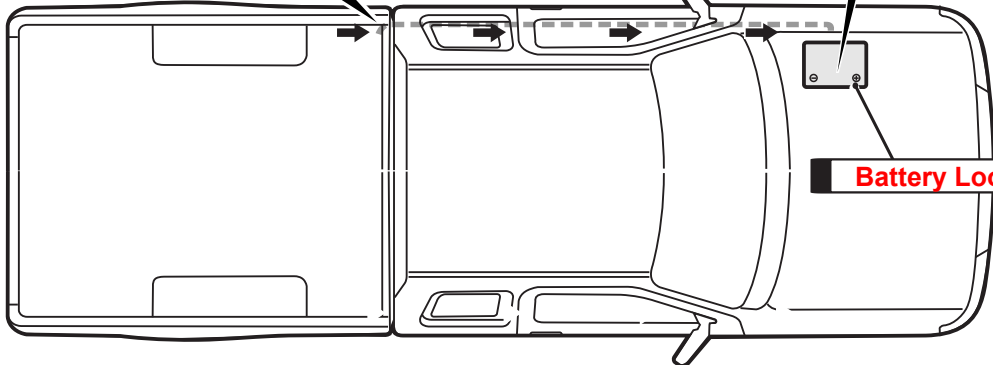

Run the wiring from the front corner cavity ( leaving 200mm in the tub) to the battery over the chassis rail. Making sure to keep away from hot obstructions and cable tie every 400mm. Reconnect fuse patch to battery loom S2.75, now attach fuse patch to positive of battery and earth to the body of the Ute.

Feed CL-Long-Loom through drivers side cavity leaving 200mm in the tub.

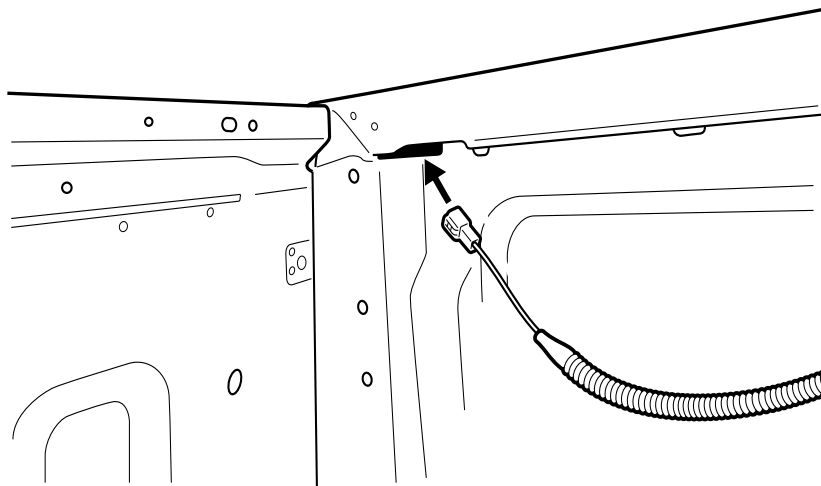

Run wiring from front tub corner cavity to drivers side kick panel. Cable tie wiring every 500mm over chassis rail. Find the large grommet on the firewall, make a small incision & run the loom through it to enter the cab and towards the kick panel. Seal accordingly.

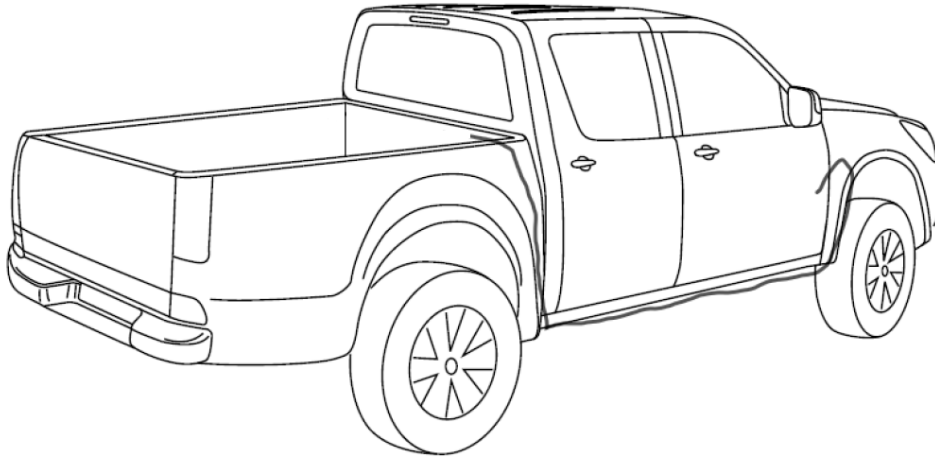

Carefully remove the drivers side scuff plate.

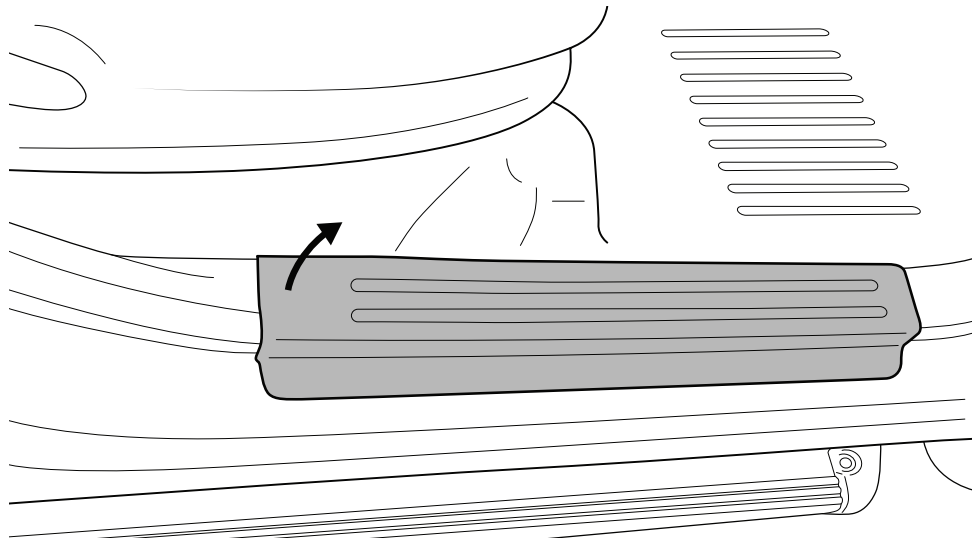

Remove kicker panel.

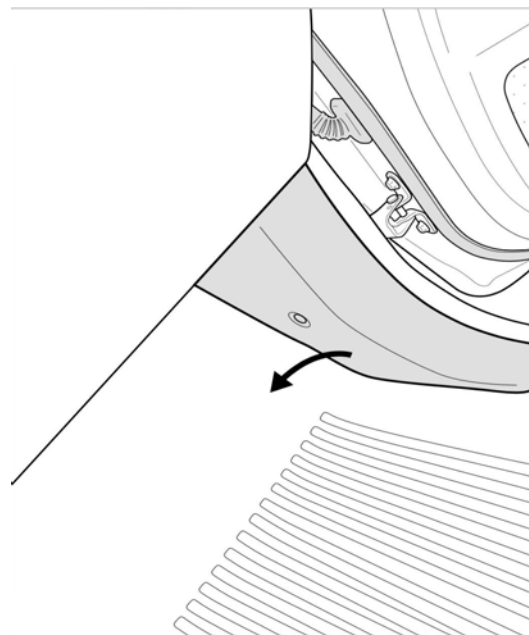



locate the central locking loom connector.  
It will be deep in the pillar cavity leading  
towards the door. Now disconnect the  
plug indicated.

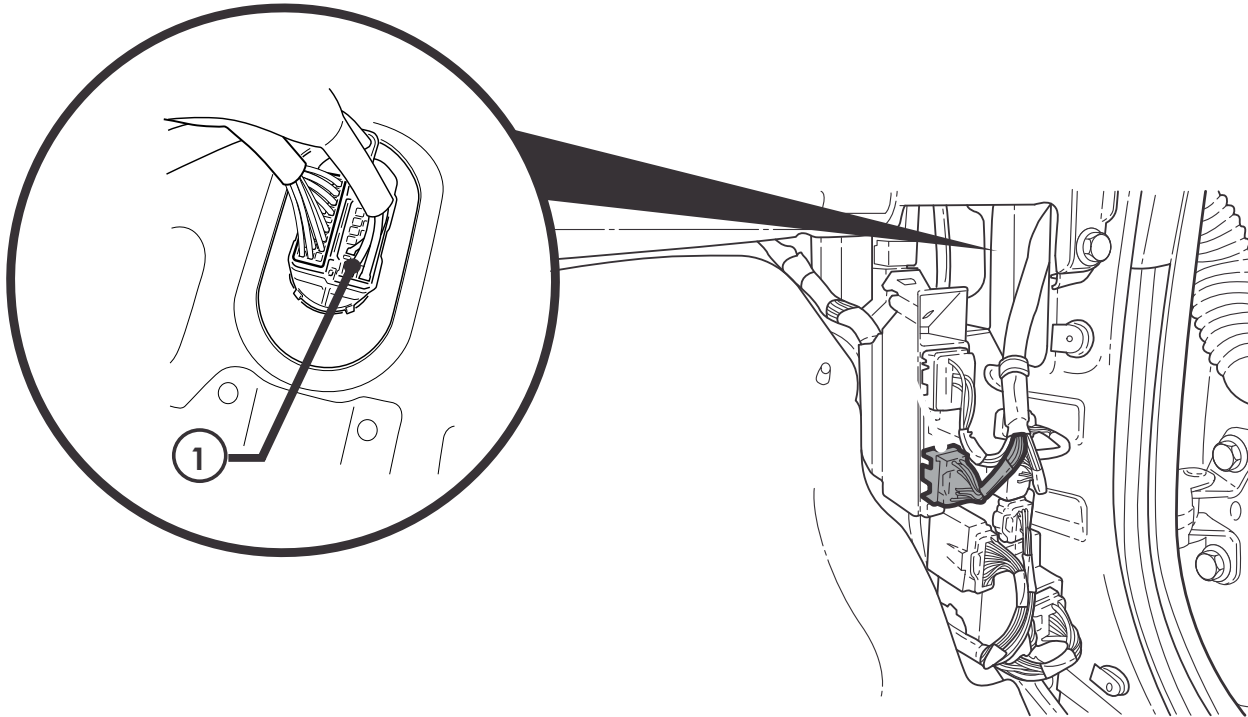

connect the GWM-patch connector provided to the vehicle connector (piggyback)

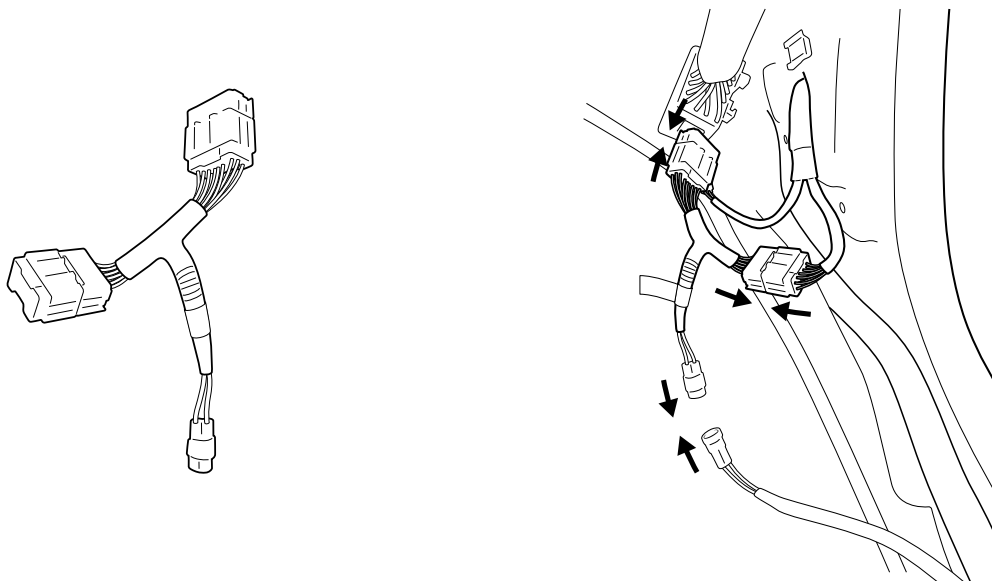

Now connect the GWM-Patch to the CI-Long-Loom

Note: Re-fit kick panel and scuff plate.

keep the cannister in the foam blocks from the packaging for assembly.

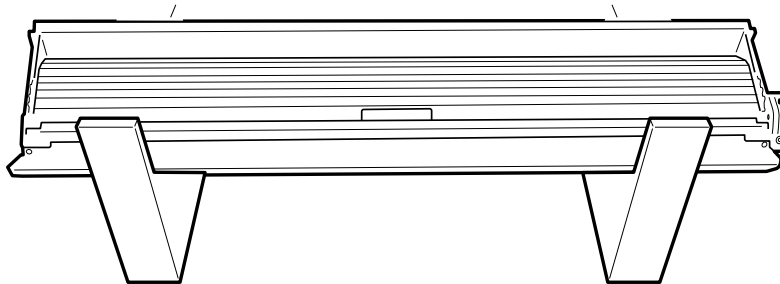
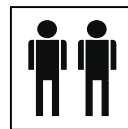

With assistance turn the canister on its back on the foam blocks.

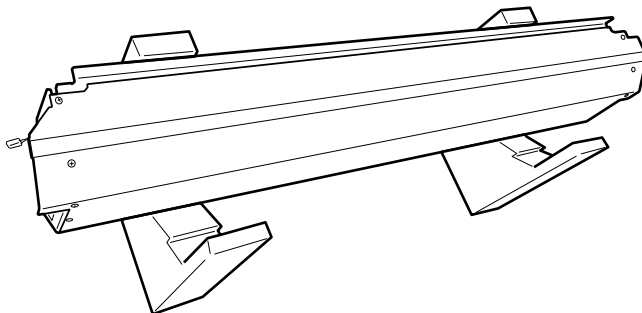

Disengage motor from the axle by unfastening the 3 Screws as indicated. Retain all parts.

Remove and retain the 3 screw from the canister as indicated.

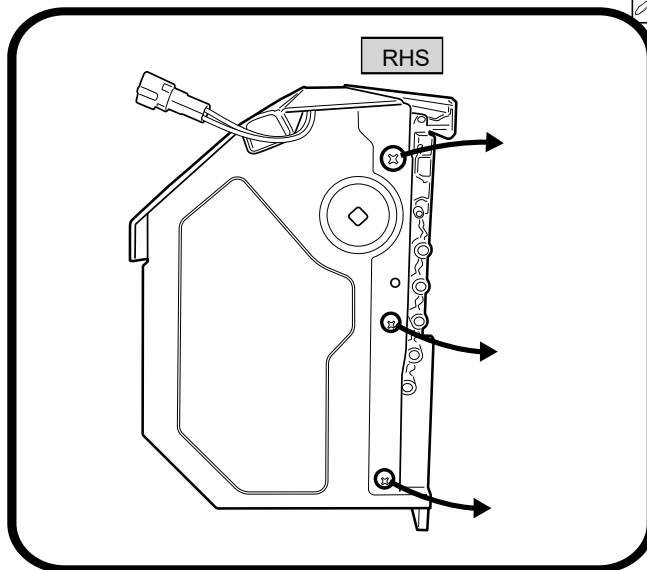
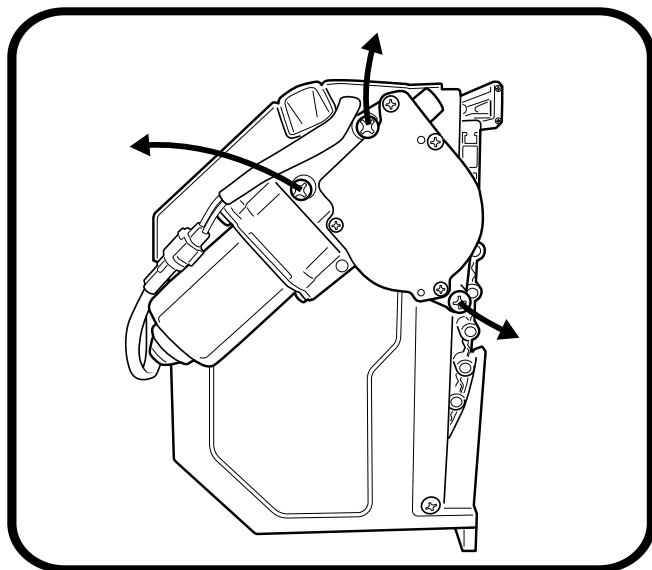
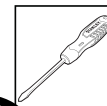

Now on the other side, remove and retain the 4 screws from the canister as indicated.

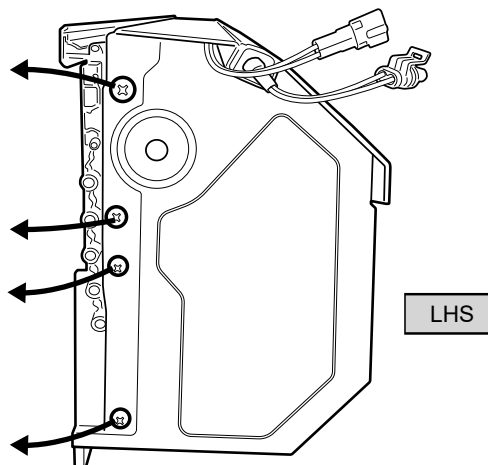
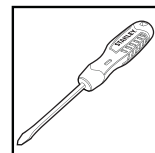



**Important Note:** Ensure that the Z seal within the track is positioned over the curtain and not folded inward. **WARRANTY** voided if assembled incorrectly.

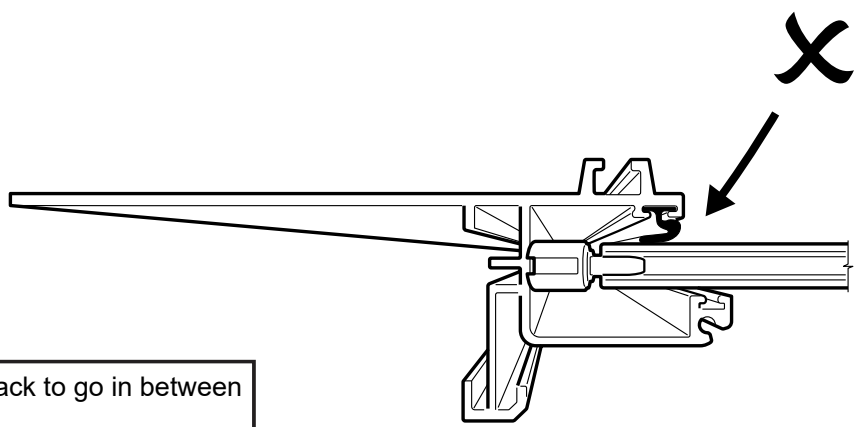
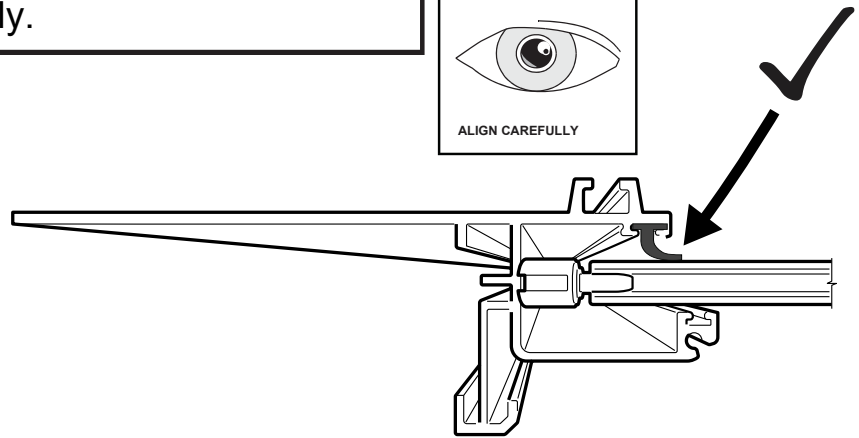

 **VISUAL TIP**

Align side rail to side of canister, guide the track to go in between the curtain end rubber stop.  
NOTE: LHS side rail to be assembled first.

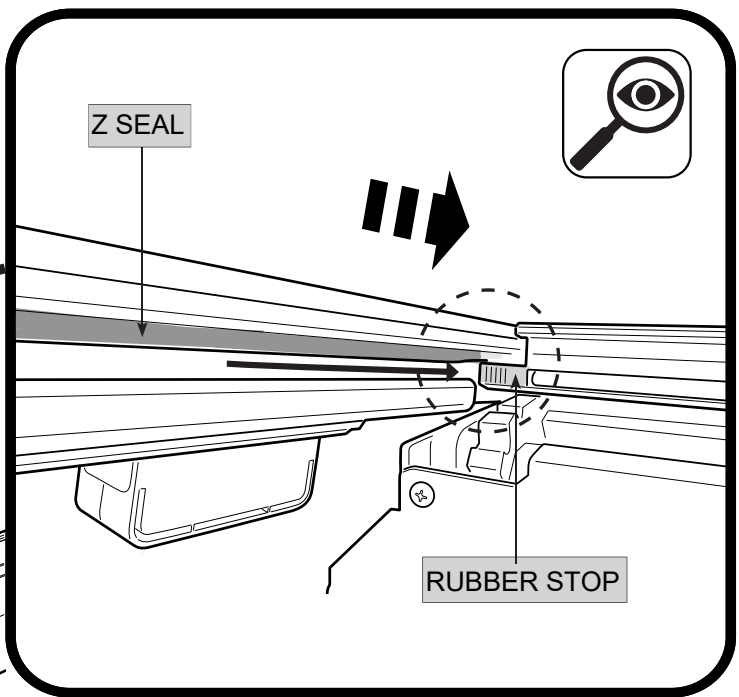
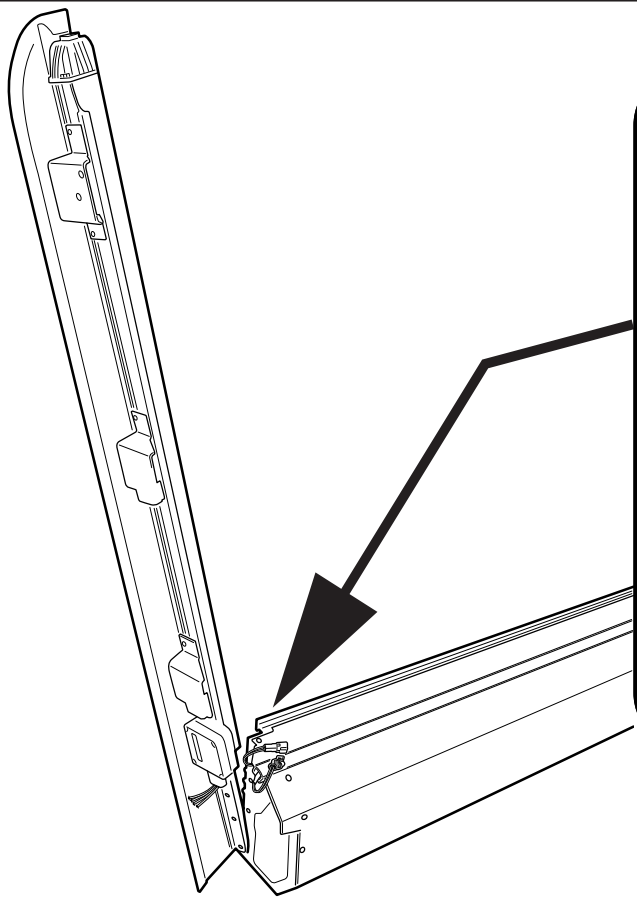

1. Using the retained screws, spring washer and washer, Loosely fasten the side rail to the location indicated.
2. Side rail edge must compress and meet with the canister profile as indicated below.
3. Fasten all screws tight.

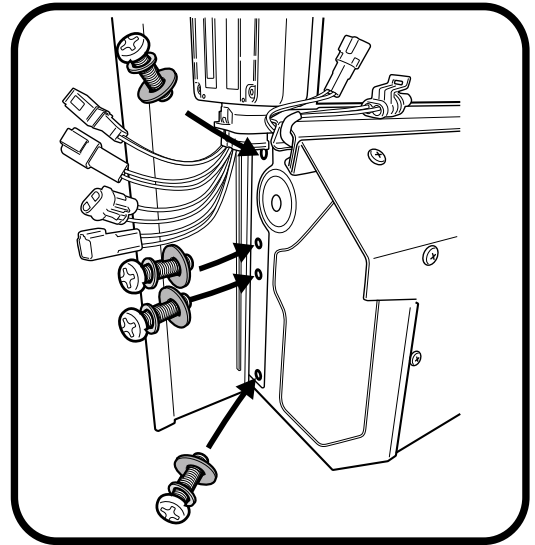
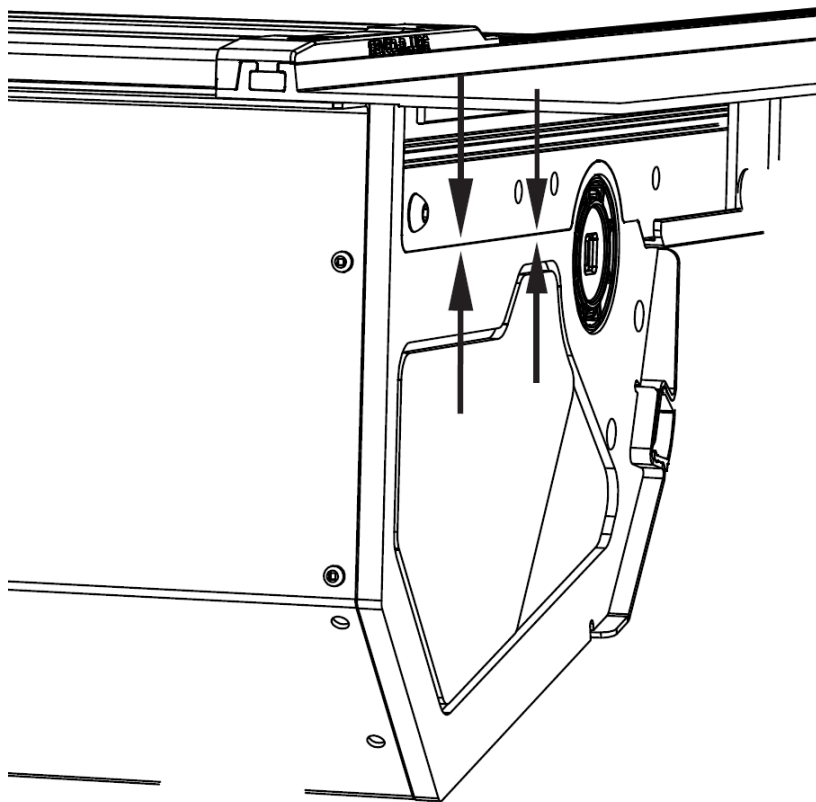
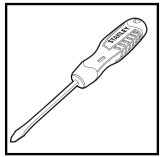

Connect motor connector to receiver

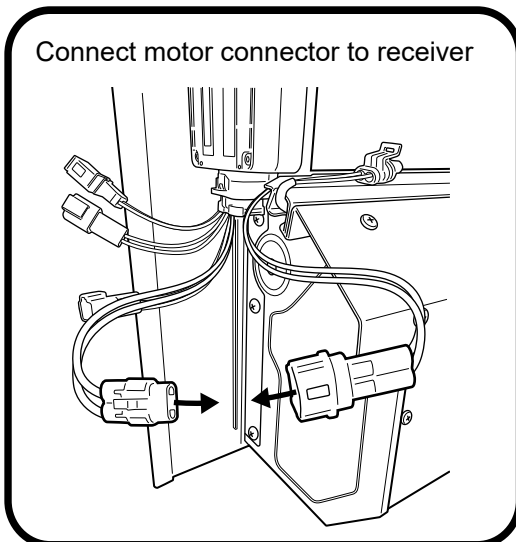

Connect LED Loom to receiver

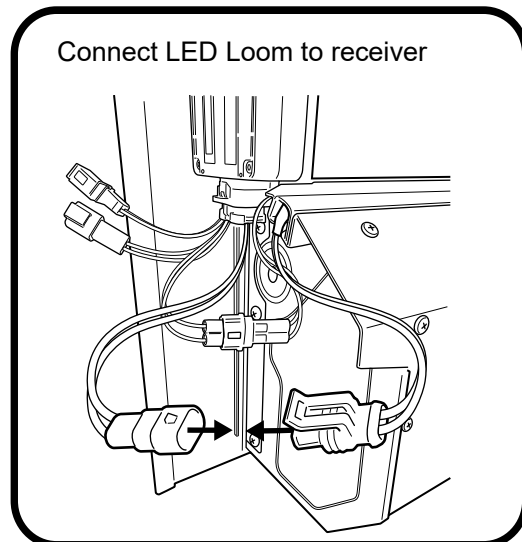



**Important Note:** Ensure that the Z seal within the track is positioned over the curtain and not folded inward. **WARRANTY** voided if assembled incorrectly.

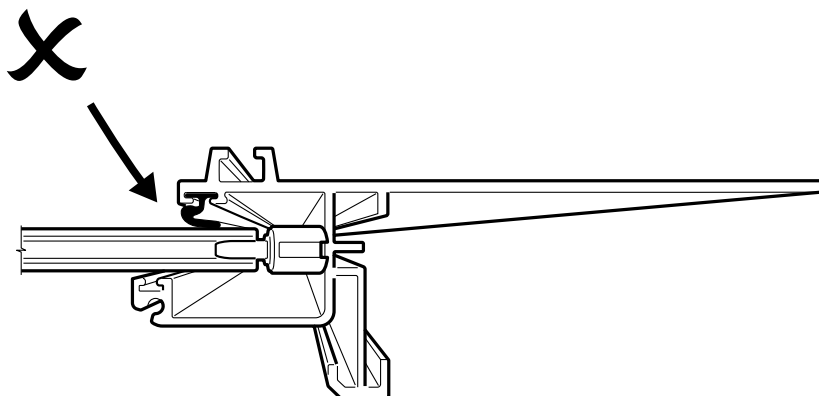
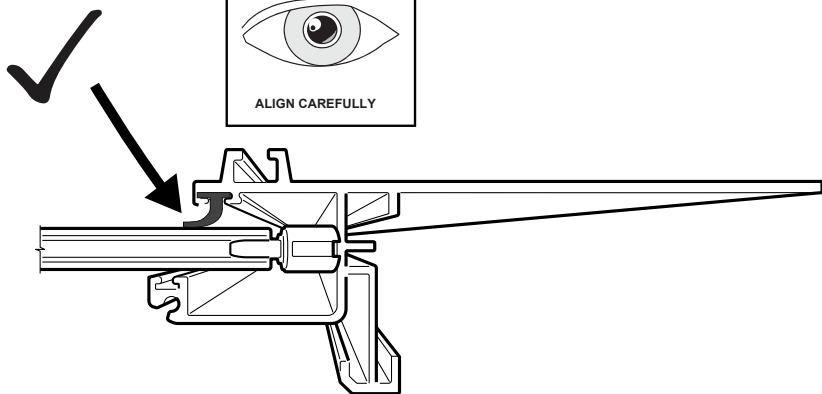
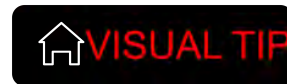

Align side rail to side of canister, guide the track to go in between the curtain end rubber stop.

NOTE: LHS side rail to be assembled first.

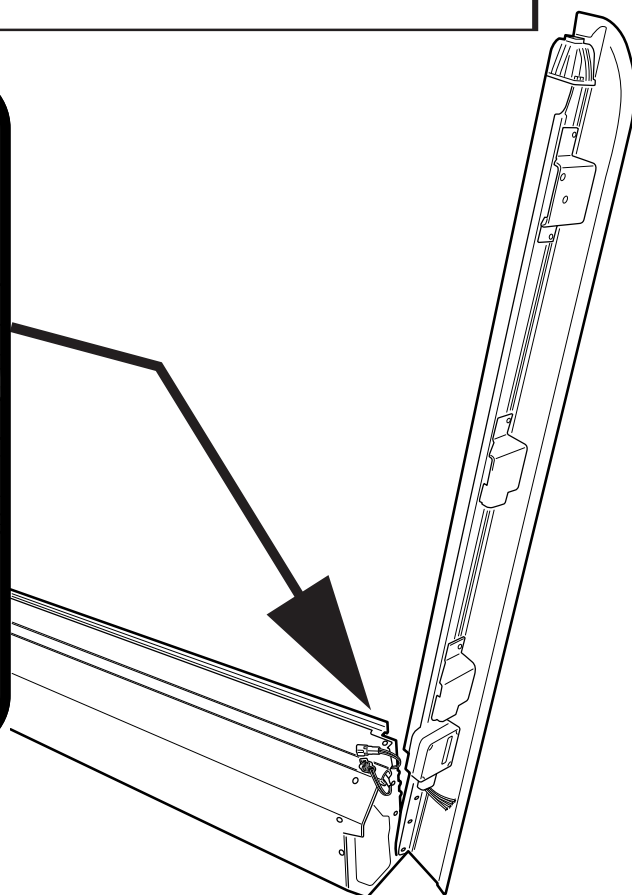
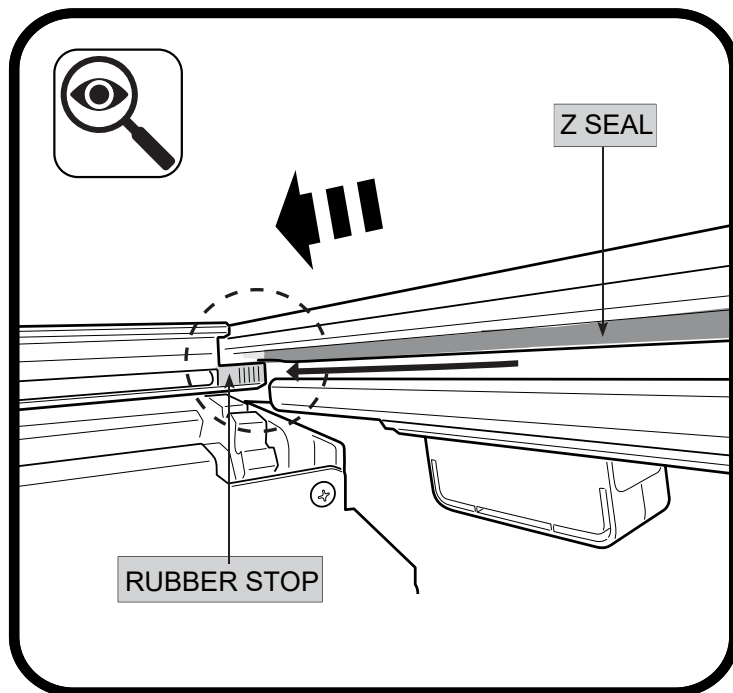

1. Using the retained screws, spring washer and washer, Loosely fasten the side rail to the location indicated.
2. Side rail edge must compress and meet with the canister profile as indicated below.
3. Fasten all screws tight.

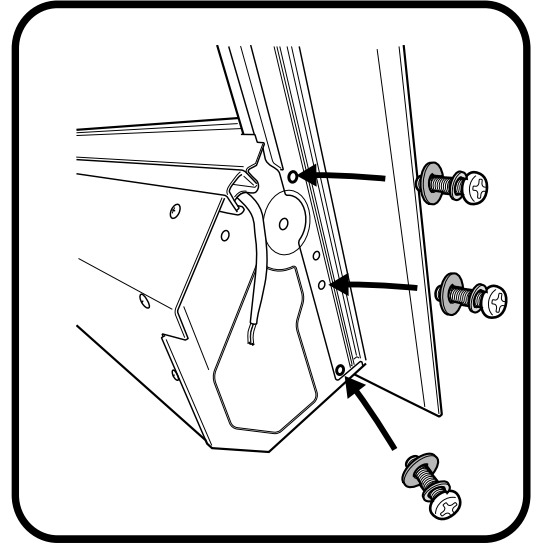
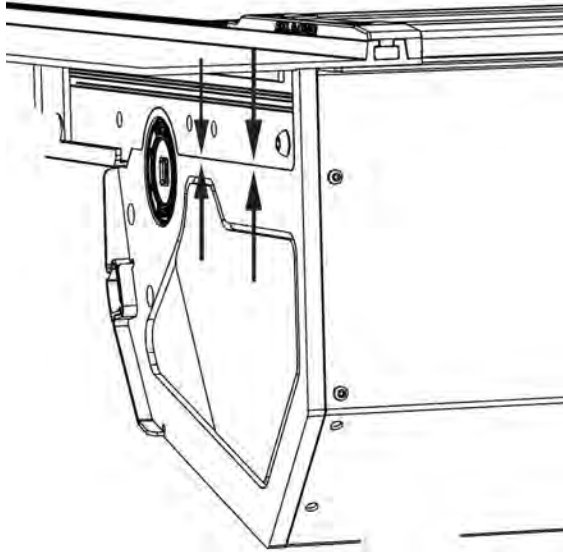
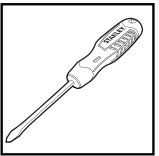

Feed M6 bolt through spring washer, motor and rubber bush.

**NOTE:** Rubber bush orientation has to be as per image. ( side with text on rubber, to face the motor).

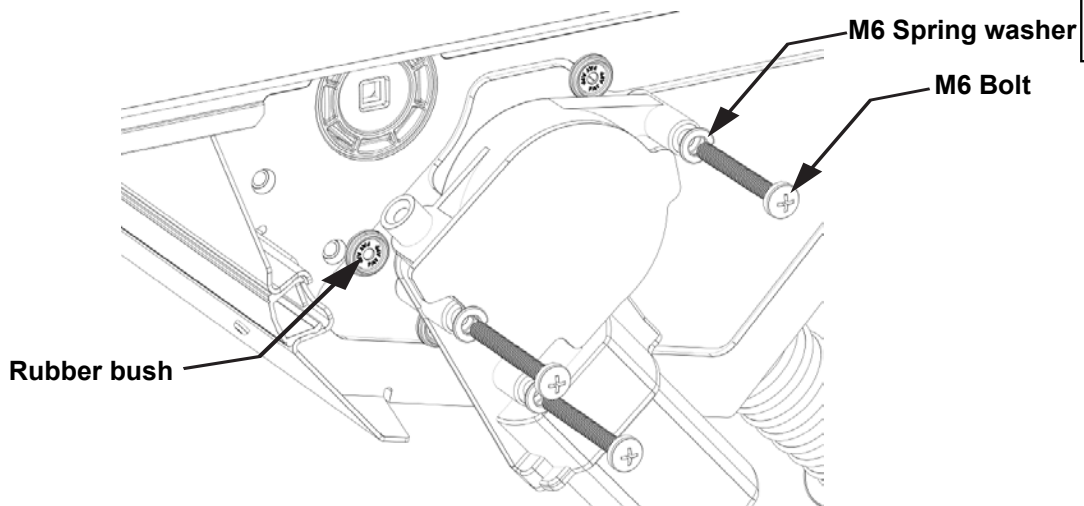
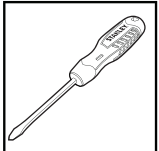

Align & insert motor shaft to axle.

**NOTE:** Pull / push curtain for axle to rotate.

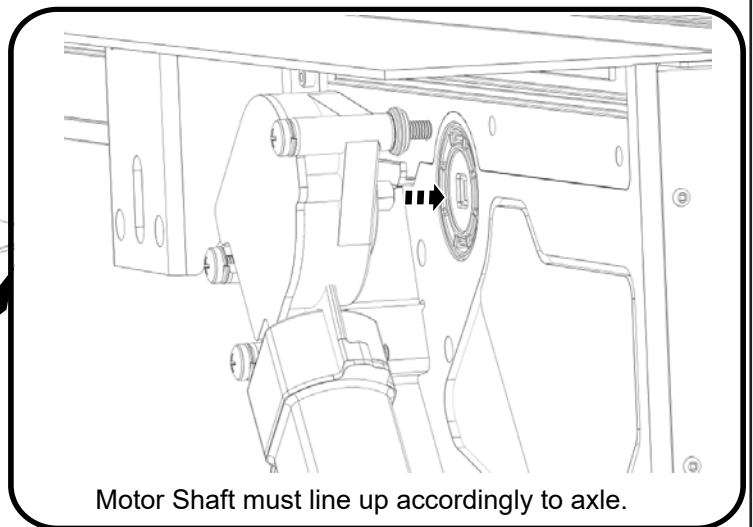
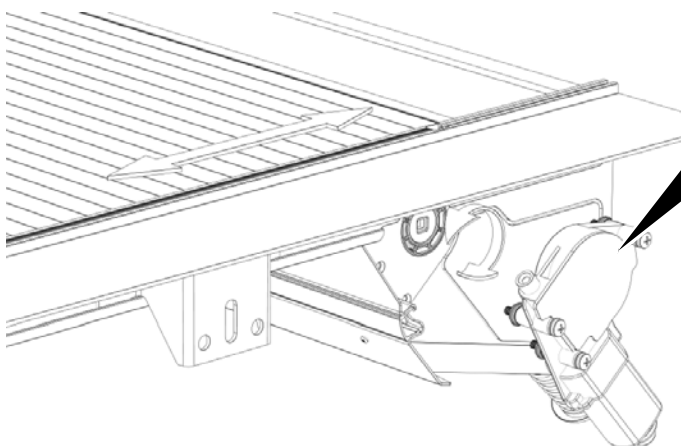

Fasten all 3 screws to 2nm torque. Over tensioning will cause operating issue's.

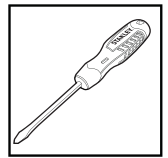
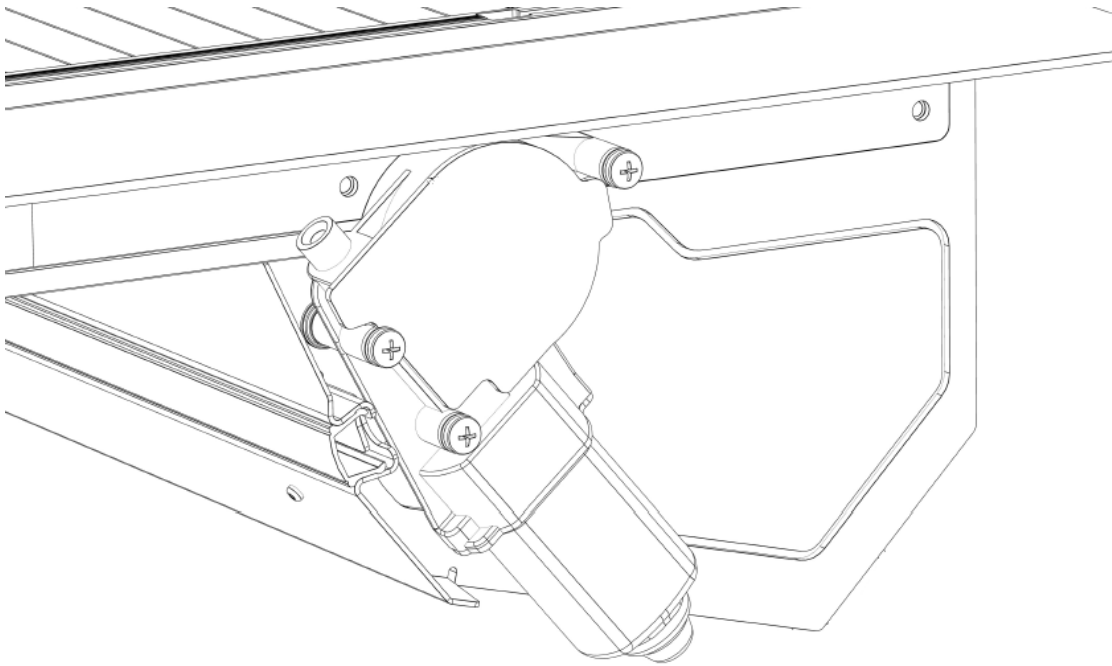

**Motor is to sit level.**

Any obstructions between motor and canister may cause operating issues.

Apply D-sponge foam tape to side rail as indicated. NOTE: Join foam firmly to the per-fitted foam of the canister. Carefully trim excess off & discard as indicated. Repeat on the other side.

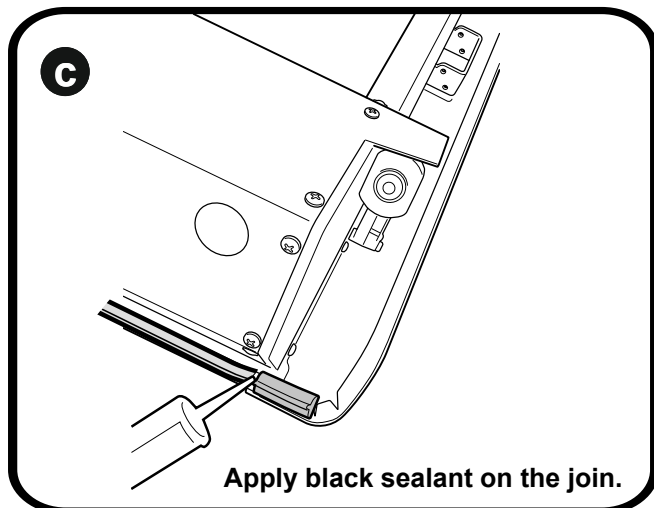
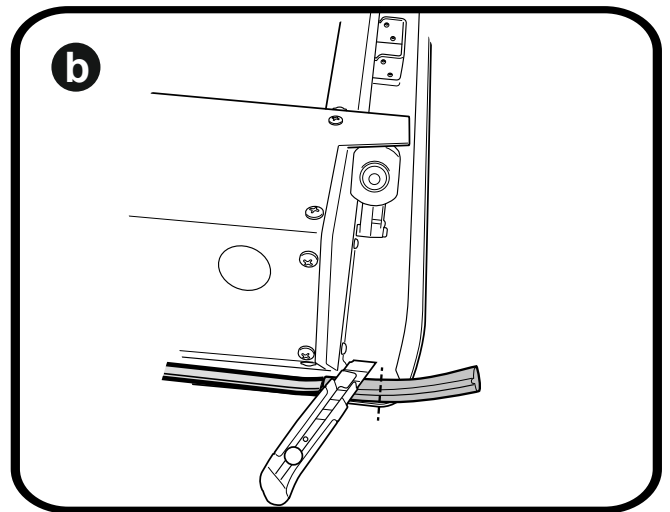
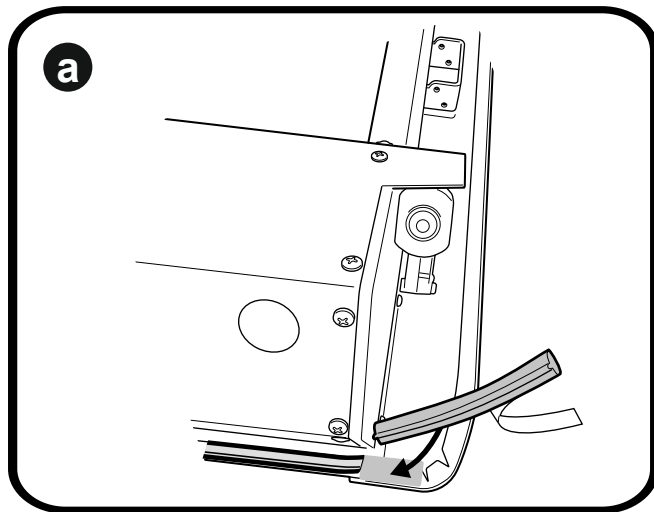

Apply black sealant on the join.

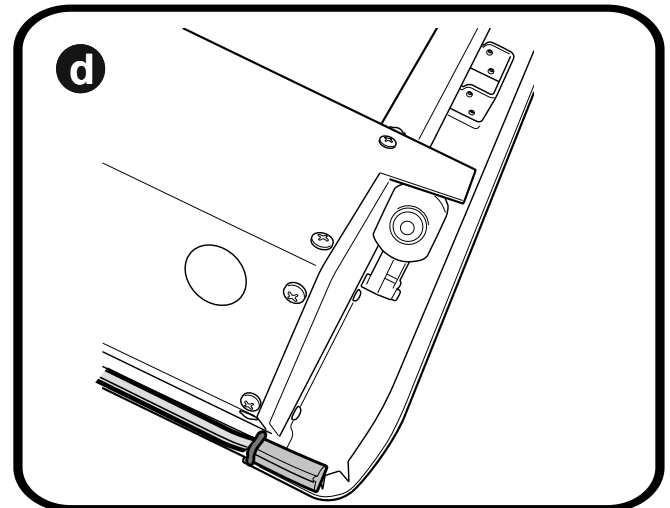

Carefully bring down the assembled unit.

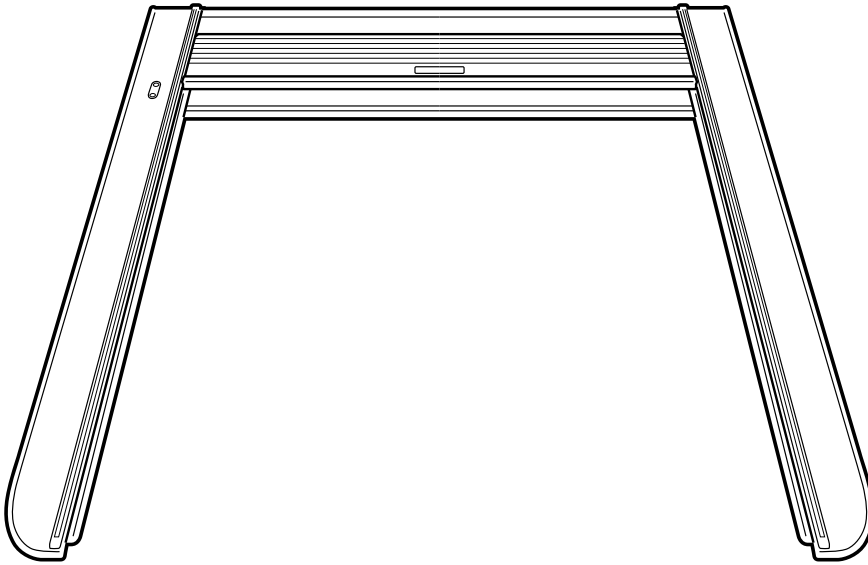

Insert side end caps to the top cover.

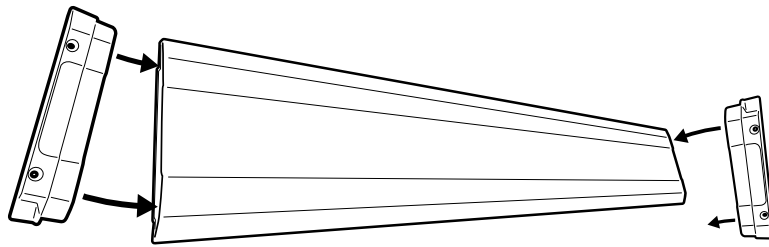

Place & Align top cover over the canister and side rails.

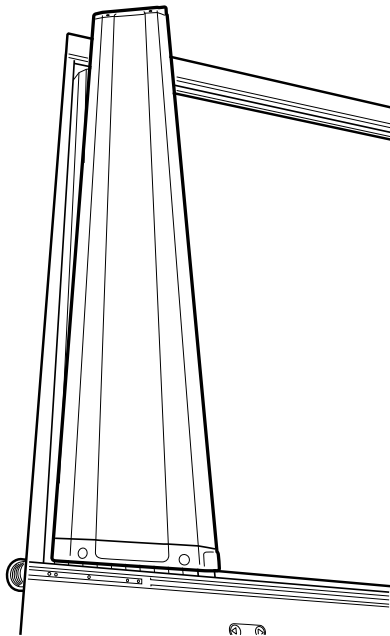

Using countersunk screws provided, line up end cap holes to the threads on the side rail. Fasten to 3nm torque. Repeat to the other side.

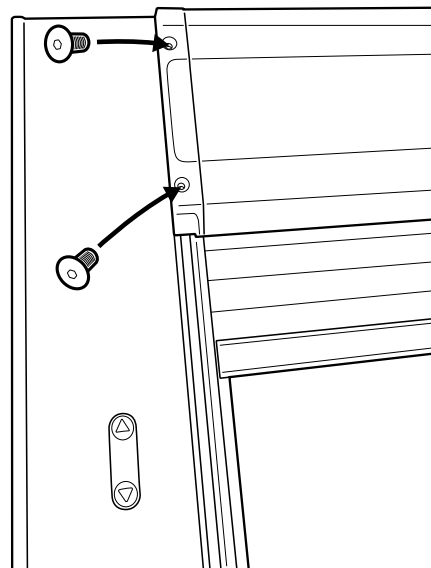



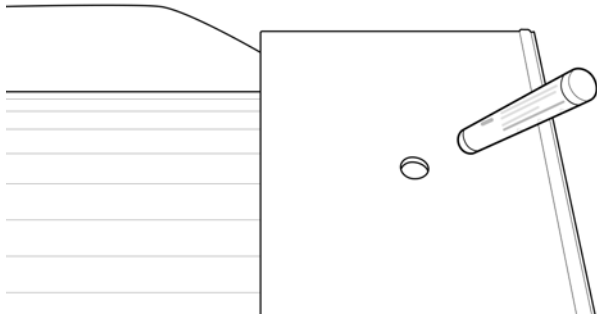

Apply 3M primer provided around all side rail holes.

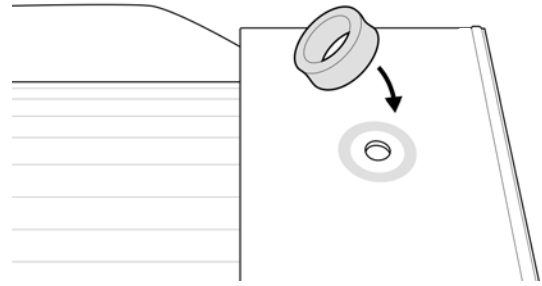

Peel away backing from foam sealant and stick to side rail. Repeat on all 6 holes.

Remove all factory rubber foot cups from sports bars. Repeat on all six legs.

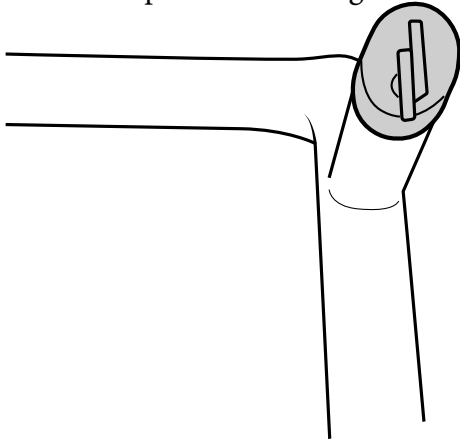

Remove all factory brackets from sports bars. Repeat on all six legs.

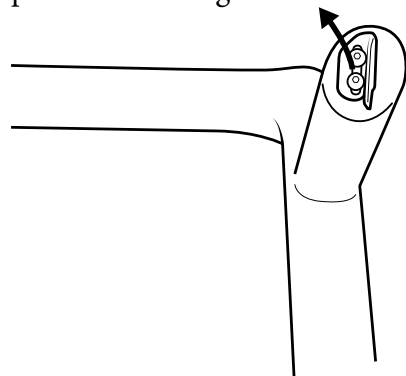

Discard factory brackets and bolts.

Trim overhang of all rubber foot cups to be level with the flat part of the cups.

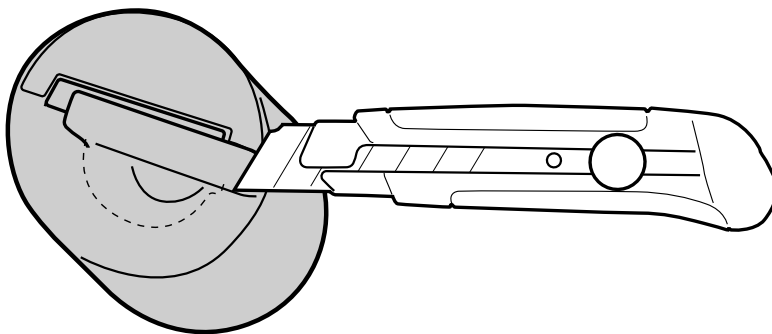

Fit the rubber feet cup back on to the sports bars legs to its factory orientation.

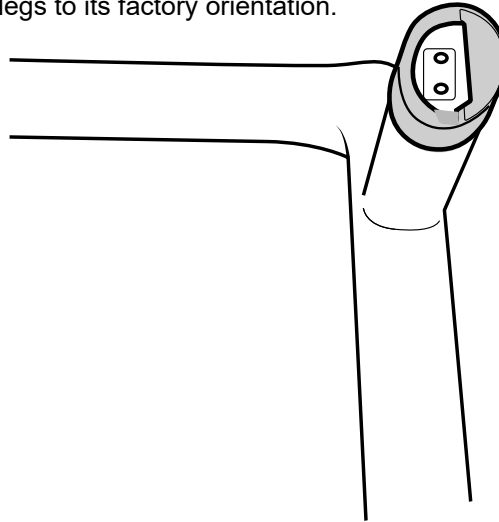

**Place Sportsbar on Roll R cover**

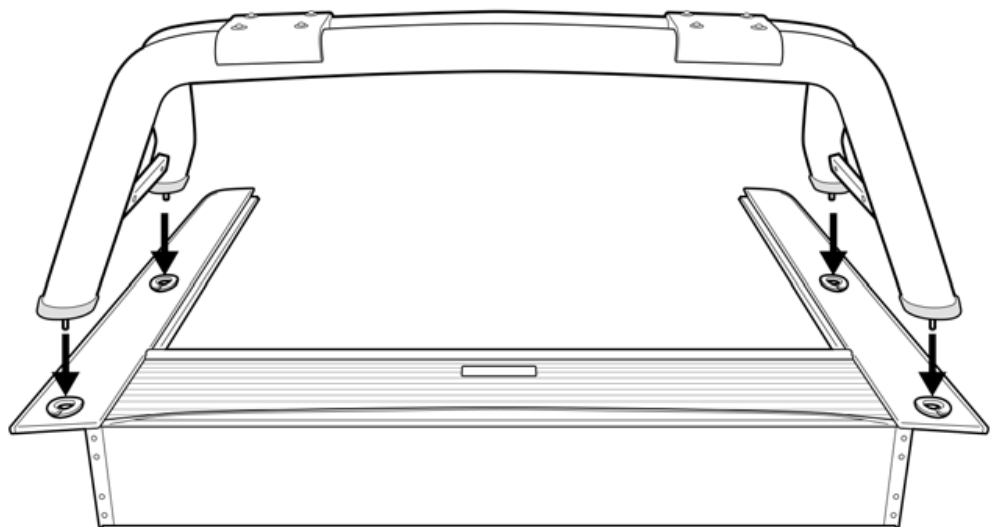

**Feed through m6 bolt, spring washer through the side rail hole, align with sports bar legs rear thread. Repeat on all four legs.**

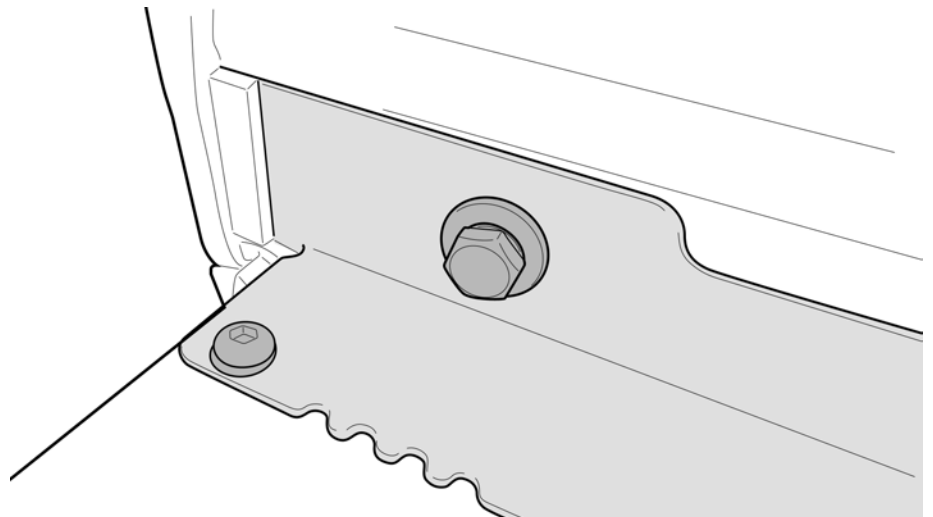
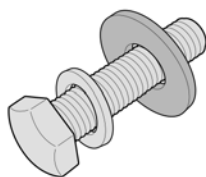

Place the Roll-R-Cover unit on to Ute bed.

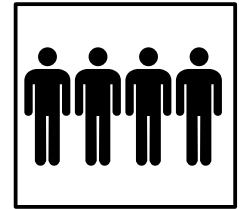
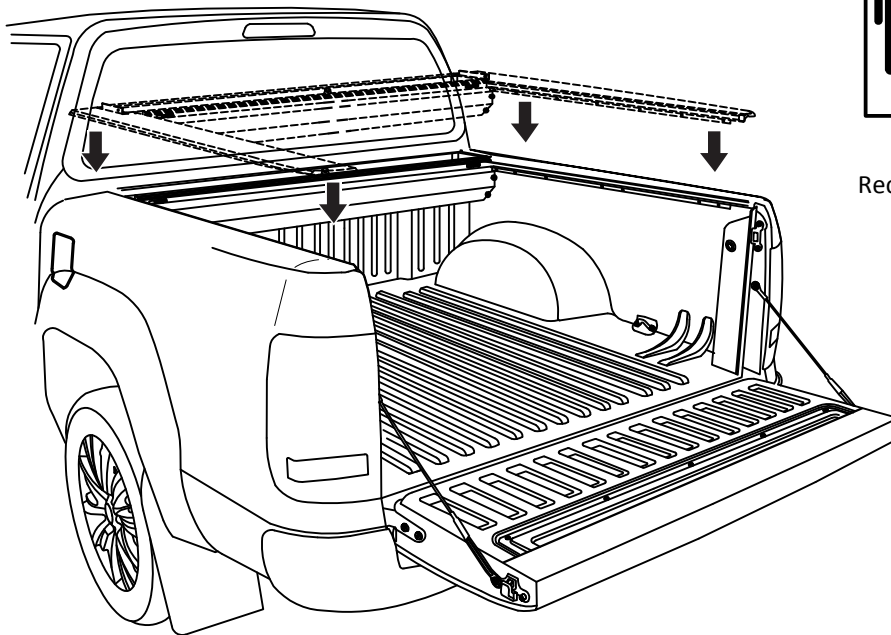

4 People  
Recommended for lift

With care, pull out any side rubber  
that has folded under the side rail.

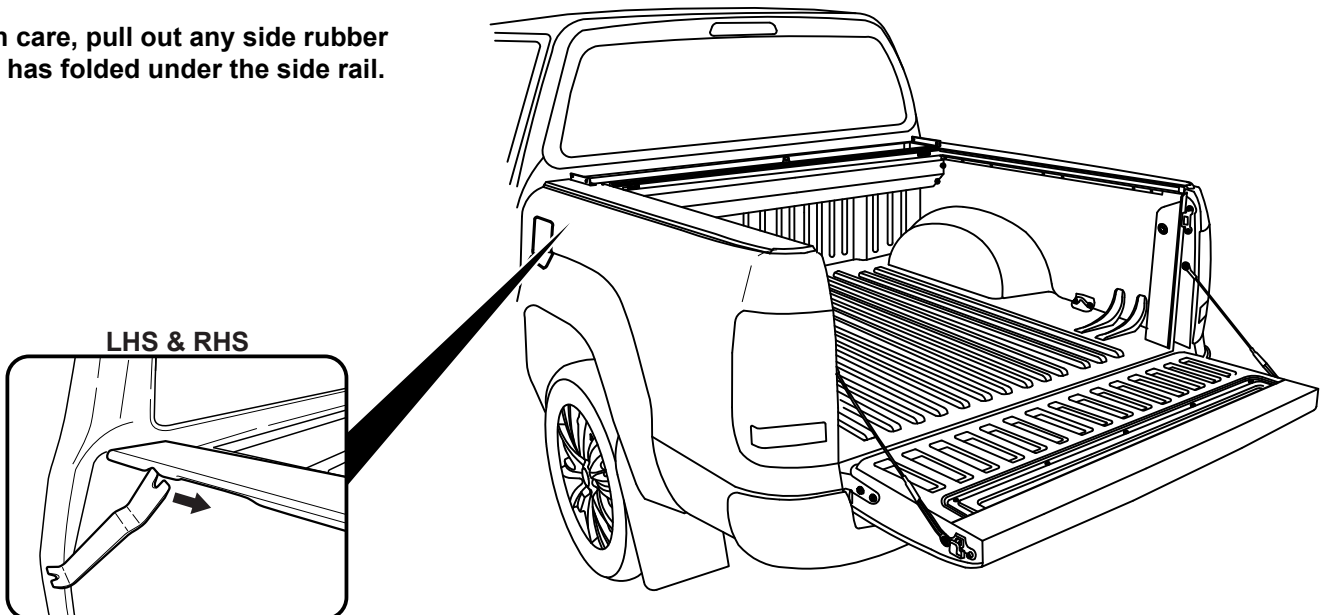

To the locations indicated below position clamp behind the inner top lip of the bed rail and the center elongated hole of the side rail mounting brackets. Repeat to other side.

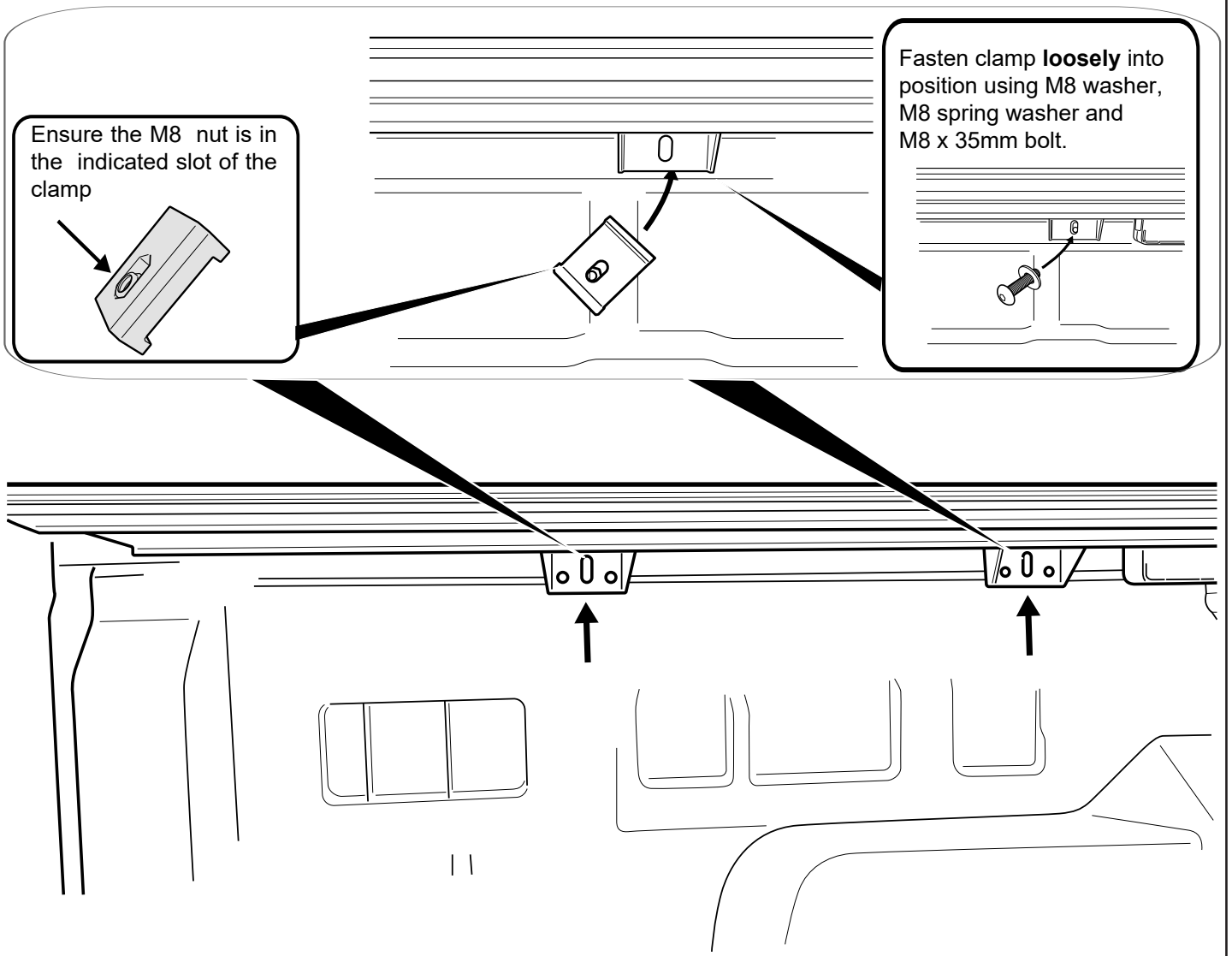

Unfasten and retain indicated factory bolt.  
Repeat to the the other side.

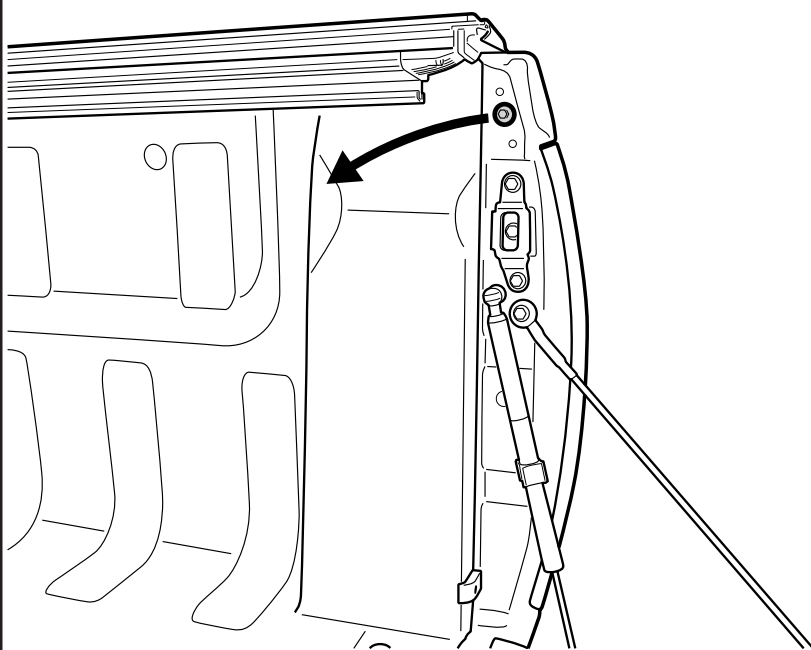

Slide part number GW4R-Rear Bracket-DS ( marked with letter D) to the rear channel of the side rail and push in all the way. **It is strongly recommended to scan the QR code and watch this step.** Repeat to the other side using GW4R-Rear Bracket-PS ( marked with letter P).



 **VISUAL TIP**

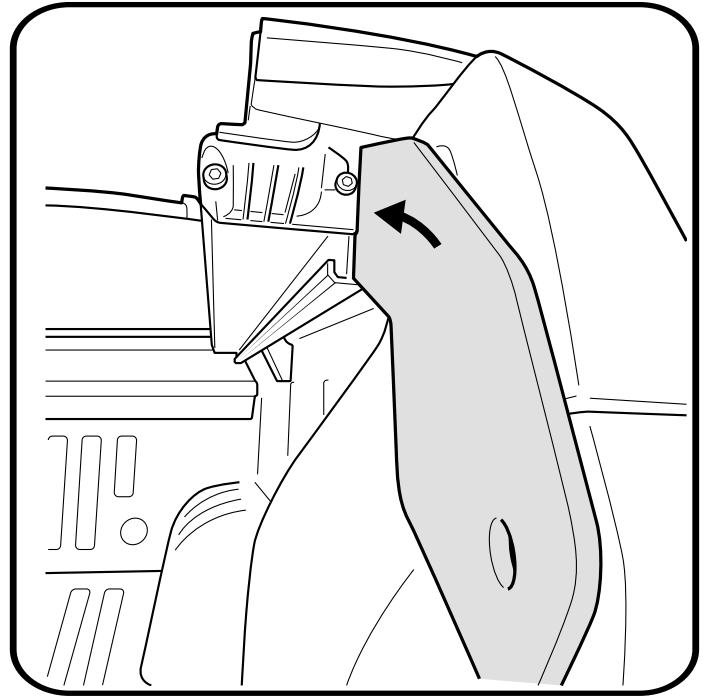
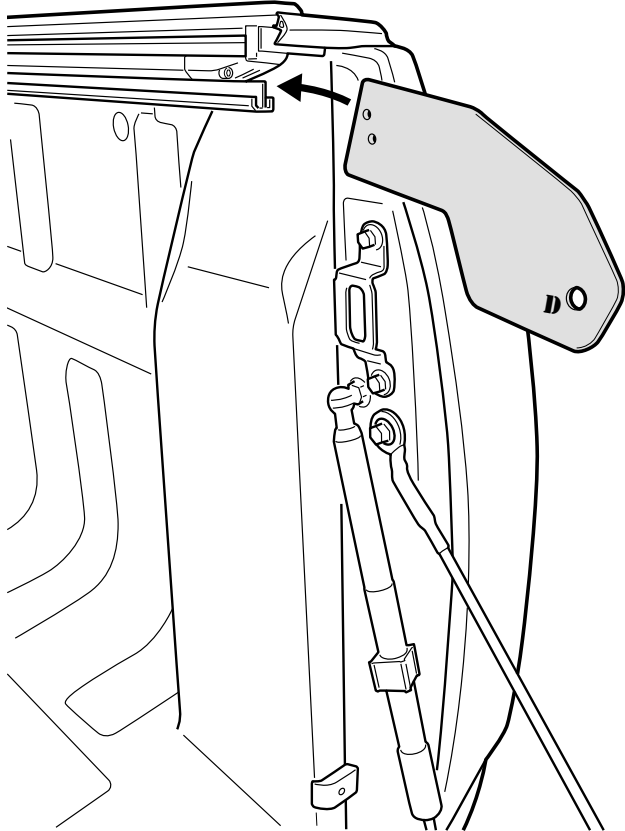

Align the hole of the bracket to the thread of the tub.  
Now loosely fasten the into position using the retained factory bolt.  
Repeat to the other side.

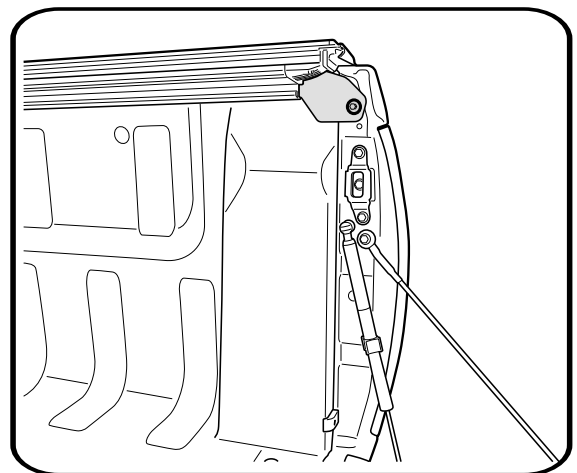
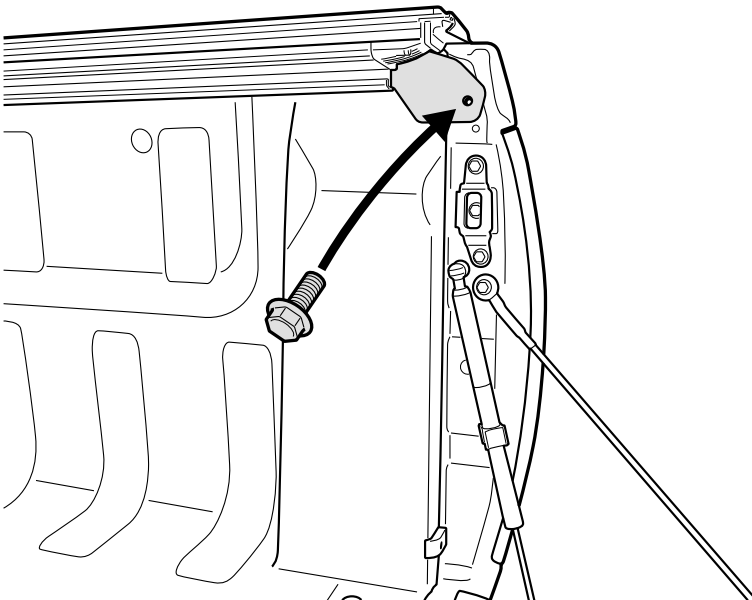

With the tailgate up (Closed position), Pull left & right hand side rails towards the tailgate, stopping short by 5mm between tailgate and side-rail end-cap. Repeat to other side.

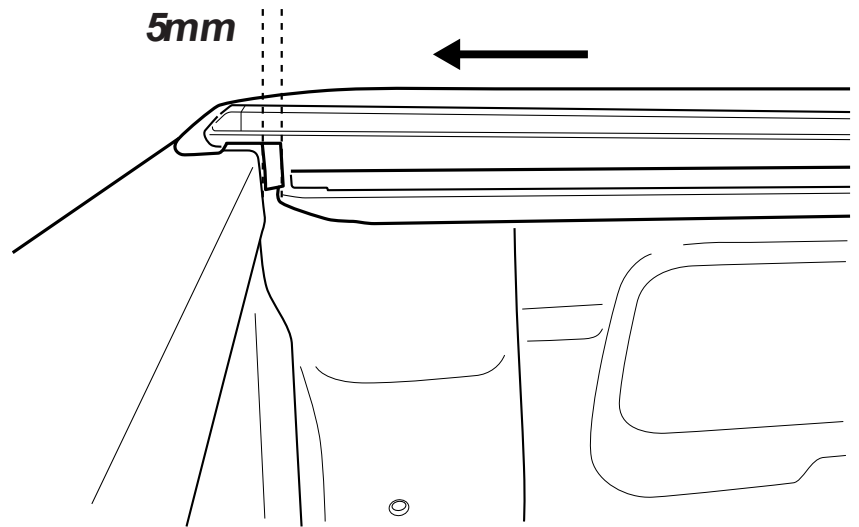

Foam compressed to 5mm when tailgate is closed.

Gap between tailgate and side-rail end cap to be 5mm.

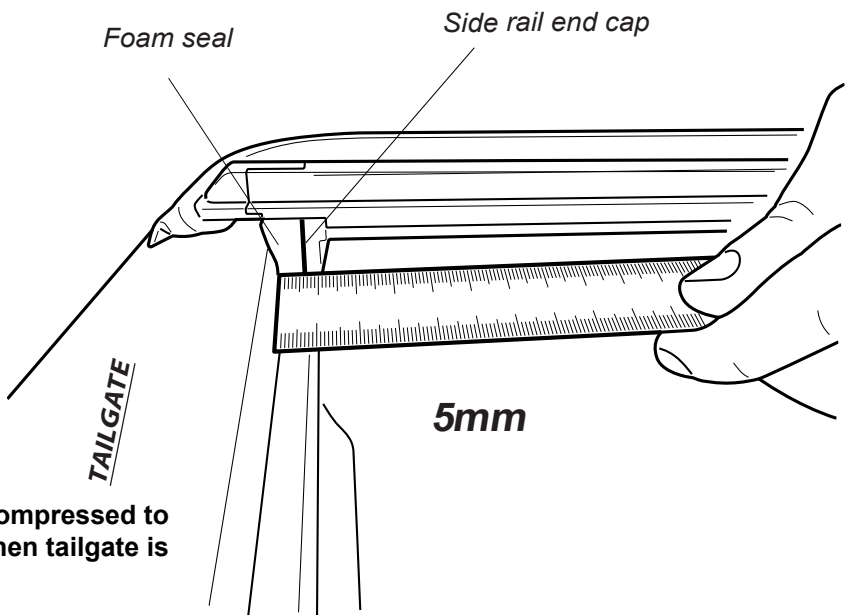

Foam compressed to 5mm when tailgate is closed.

1. Apply downward pressure on the inner part of side rails.
2. Raise the clamp all the way up or as close to the top as possible, then securely fasten the clamp in the specified order (A) and then (B) to a torque of 14Nm.

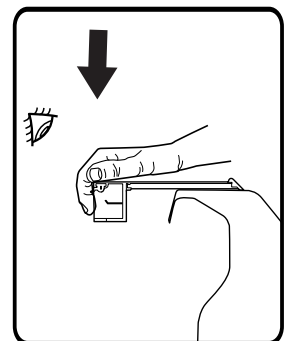
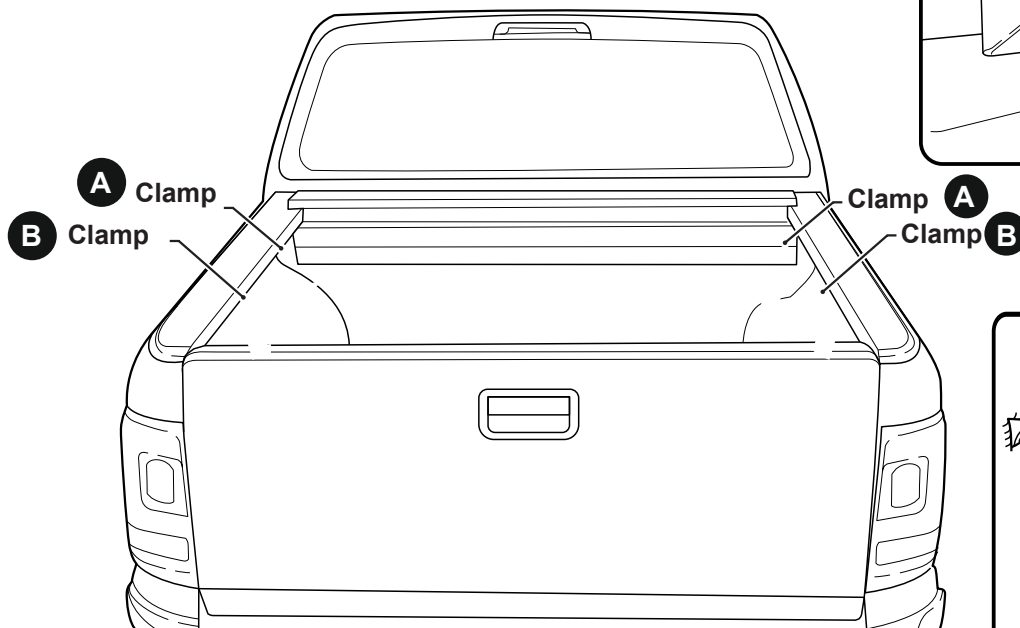

With the help of an assistant, apply gentle downward pressure to the side rail surface, causing slight compression of the outer side rail seal against the tub's top rail, while ensuring the side rail remains level. Next, securely tighten the indicated bolt to torque of 8Nm.

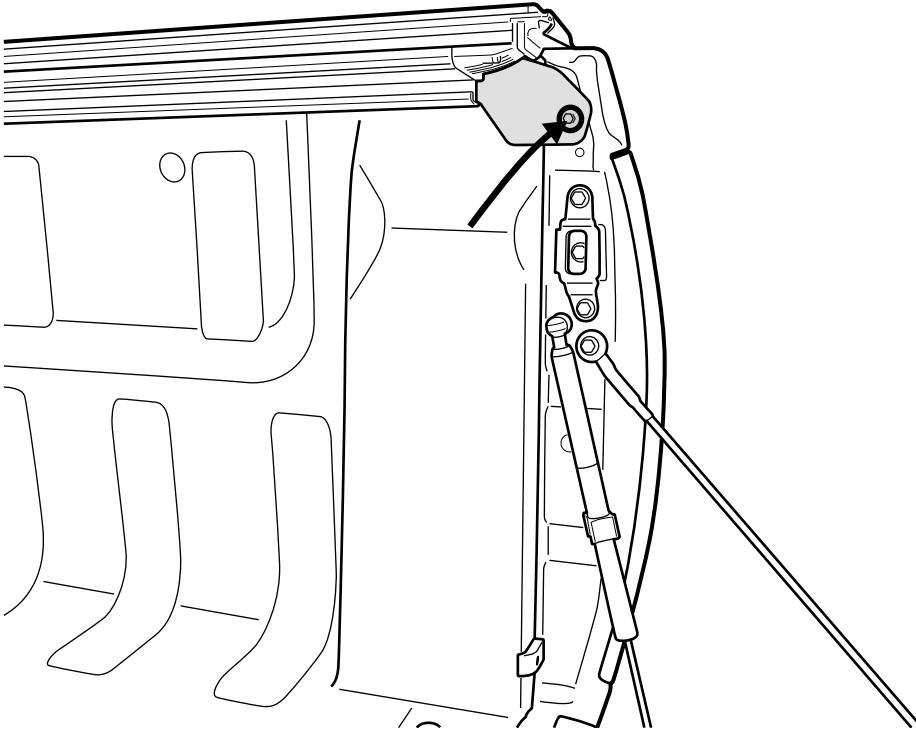

Side rail to sit level, side rail seal will slightly sit below the top of the tailgate in the closed position.

If required the indicated bolt can be loosened to push the side rails further down or lift up. Fasten bolt to 8Nm torque.

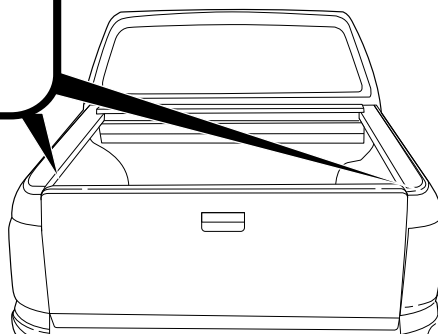
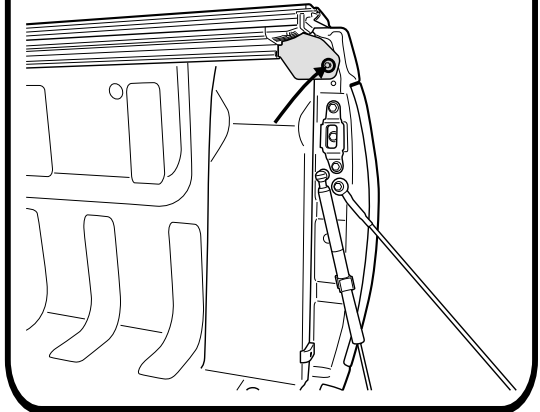
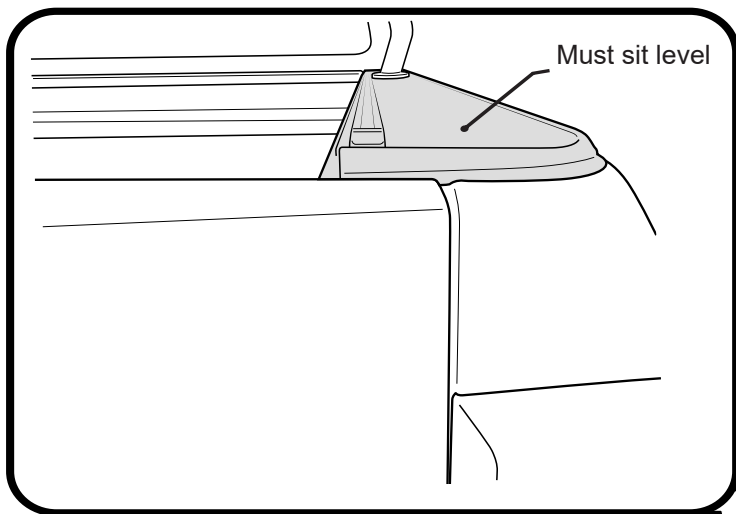

1. Clean area with non oil based cleaner, ie alcohol wipe.
2. Apply clear protective tape to left and right top corners of the tailgate as indicated.

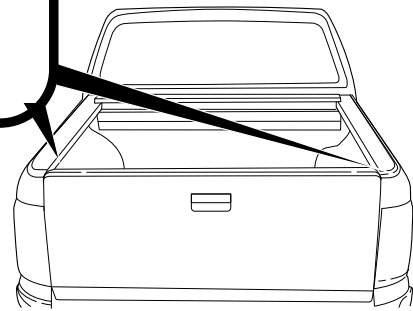
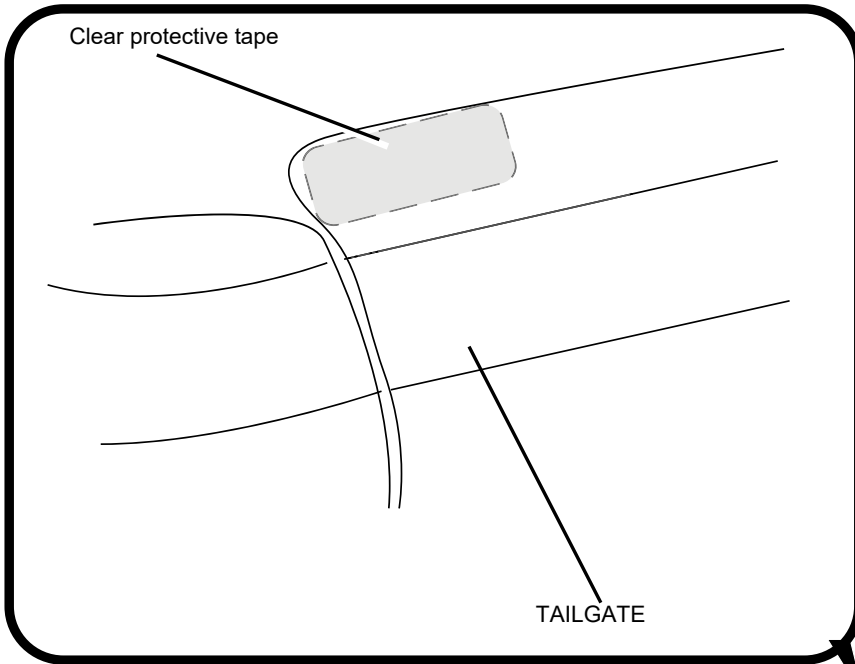
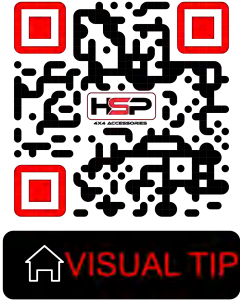



**Install front drain pipes through pre-drilled holes of the canister. ( RHS/LHS)**



Note: With care push tube in. Gently pull the tube back so it seals correctly against the front panel of the tub.



VISUAL TIP

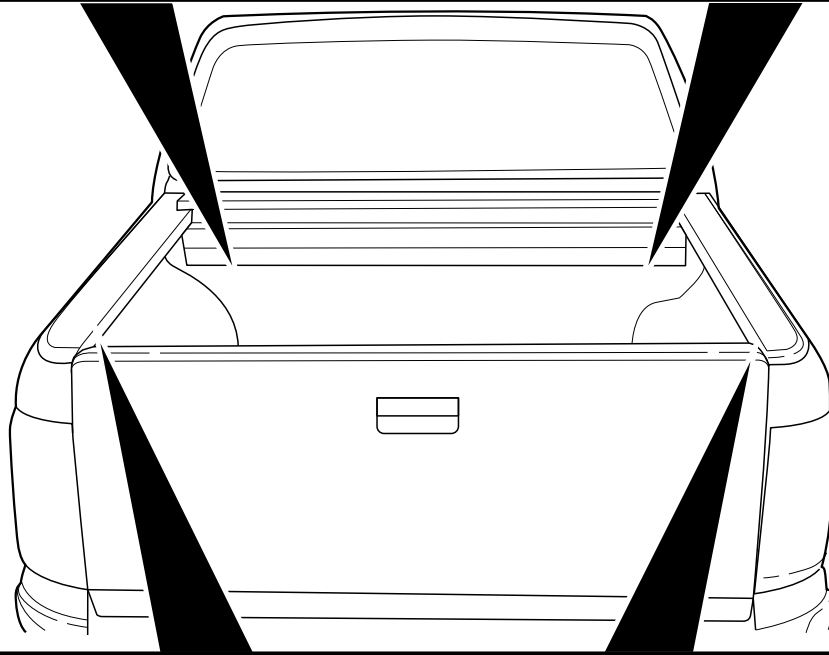
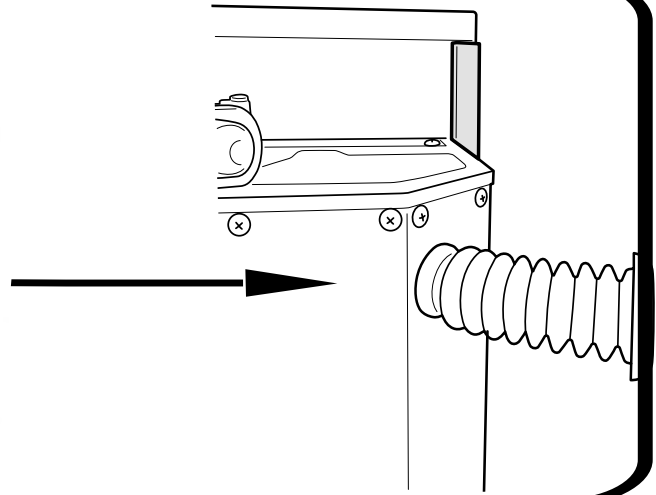
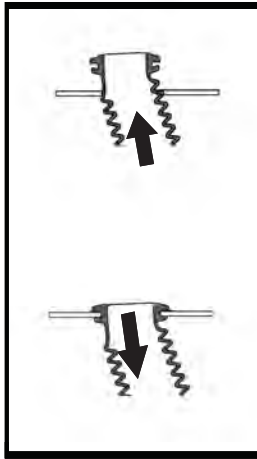

Note: With care push rear pipe in. Gently pull the pipe back so it seals correctly within the side rail channel.

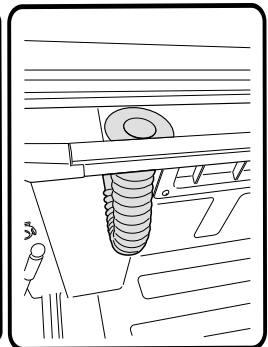
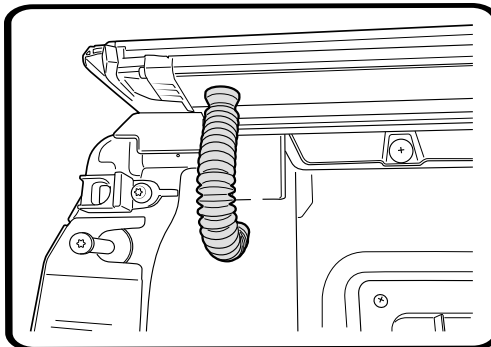
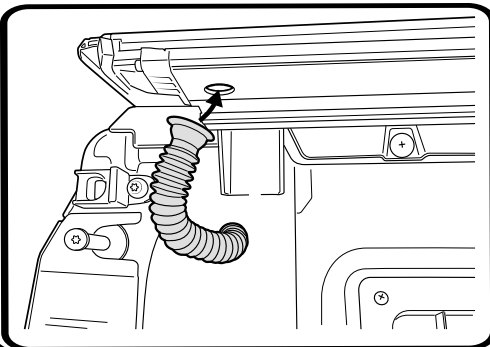
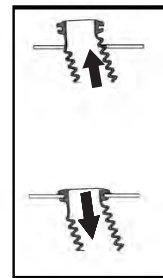

**Install rear drain pipes through pre-drilled holes of the siderails. ( RHS/LHS)**

- a. Connect Battery loom S2.75 to Receiver loom.
- b. **Carefully** connect S3-CL-PATCH to Receiver loom.



Align connectors carefully to avoid pushing pins out.

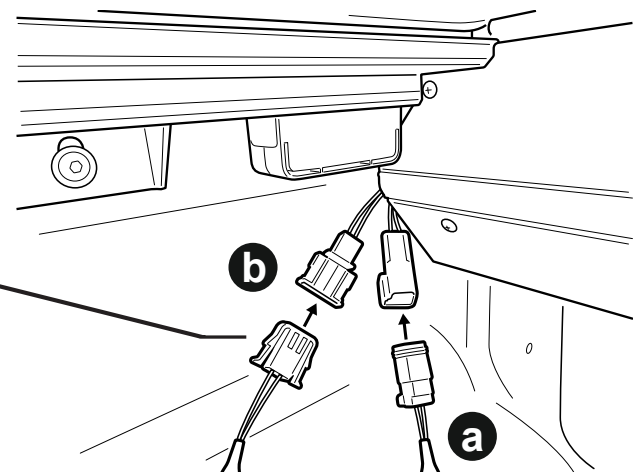

Carefully connect CI-Loom-Long to S3-cl-patch.

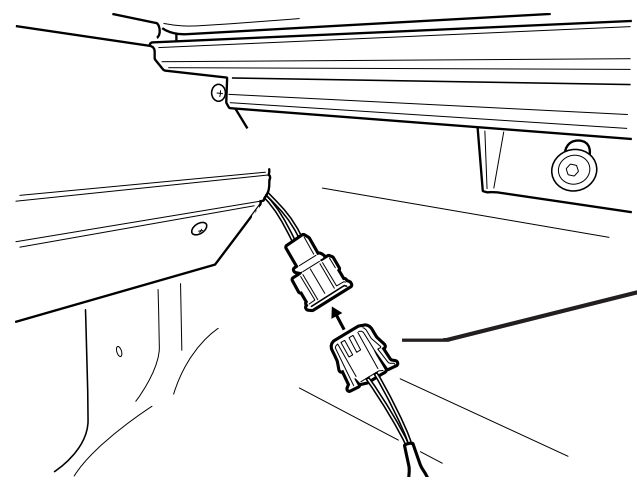

Align connectors carefully to avoid pushing pins out.



**Operating instructions:**

Press unlock on vehicle key fob to activate controller.  
 When vehicle is unlocked the side rail sensor buttons will be active to control.  
 When vehicle is locked the side rail sensor buttons will be inactive.

**Using factory key fob to operate:**

Pressing unlock twice on the factory key fob within 4 seconds, will activate the roll r cover to open.  
 Pressing lock twice on the factory key fob within 4 seconds, will activate the roll r cover to close.

**Vehicle proximity:**

Tapping the proximity twice to open or lock the car door will act exactly the same way as the key fob being pressed twice.

Touch & let go to open, touch & let go again to pause.

Touch & let go to close, touch & let go again to pause.

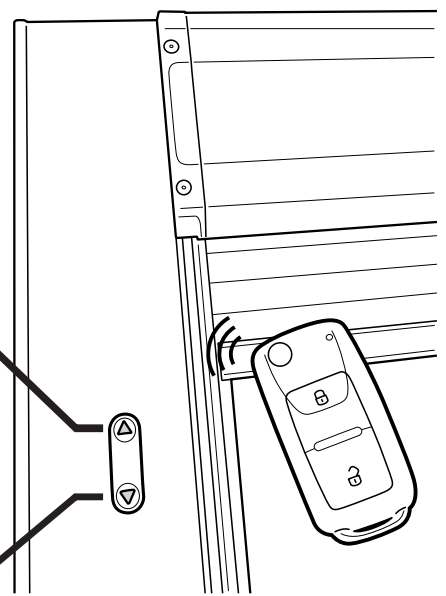

NOTE: 1. To wear in the Roll R Cover please fully open & close the cover approximately 15 times after install is complete.  
 2. Set your vehicle locking system to unlock all doors with one press of the factory remote unlock button. This setting can be found in your vehicle settings.