



INSTALLATION INSTRUCTIONS

**Vehicle Model: To suit Toyota Hilux
Revo 2016+ Dual Cab J Deck**



INSTALLATION TIME: 2 Hours (Approximately)

IMPORTANT	<ul style="list-style-type: none"> • Do not stand/sit or rest heavy objects on Roll R Cover • Humans or animals are not to be under the closed cover at any given time • Tonneau Cover is not dust or water tight • If contact with volatile chemicals occur, clean Cover with mild detergent and water solution 			
Care Instructions	<ul style="list-style-type: none"> • Read Instructions fully before commencing installation. • Clean Cover with a mild detergent and water solution • Do not use abrasive cleaners or solvents • Refer to manufactures instructions applicable to power drill. • Protect Tub floor against scratches during installation process. 			
Maintenance	Refer to Maintenance instructions.			
Tools Required	<table style="width: 100%; border: none;"> <tr> <td style="vertical-align: top;"> <ul style="list-style-type: none"> • Pen / Marker • Centre Punch • Drill & Drill bits • Caulking Gun • Silicon - Non Acetic </td> <td style="vertical-align: top;"> <ul style="list-style-type: none"> • Scissors & Knife • Spanner & Socket • Tape measure • Holesaw • Filing tool </td> <td style="vertical-align: top;"> <ul style="list-style-type: none"> • Soapy water solution • Allen Key set • Screw driver • Rust Inhibitor • Trim Removal Tool </td> </tr> </table>	<ul style="list-style-type: none"> • Pen / Marker • Centre Punch • Drill & Drill bits • Caulking Gun • Silicon - Non Acetic 	<ul style="list-style-type: none"> • Scissors & Knife • Spanner & Socket • Tape measure • Holesaw • Filing tool 	<ul style="list-style-type: none"> • Soapy water solution • Allen Key set • Screw driver • Rust Inhibitor • Trim Removal Tool
<ul style="list-style-type: none"> • Pen / Marker • Centre Punch • Drill & Drill bits • Caulking Gun • Silicon - Non Acetic 	<ul style="list-style-type: none"> • Scissors & Knife • Spanner & Socket • Tape measure • Holesaw • Filing tool 	<ul style="list-style-type: none"> • Soapy water solution • Allen Key set • Screw driver • Rust Inhibitor • Trim Removal Tool 		

PERSONAL PROTECTIVE EQUIPMENT:



Rubber Gloves



Goggles



Hearing Protection

BOX CONTENTS

LEFT & RIGHT SIDE RAIL

S2.5-DC-AE-002ps-HJ4 

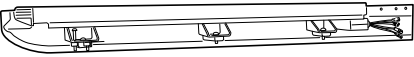
S2.5-DC-AE-003ds-HJ4 



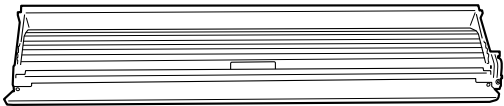







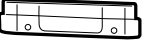

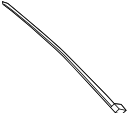
CANISTER ASSEMBLY

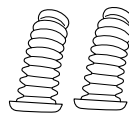



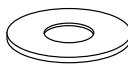

S3-DC-AF-HJ4R-001/002

CANISTER TOP COVER  S2.5-DC-AE-005 -HJ4

SPECIFIC KIT HJ4

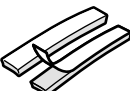
<p>COVER END CAPS</p>  <p>S2.5-DC-PI-004ps</p>  <p>S2.5-DC-PI-004ds</p>	 <p>COUNTERSUNK SCREW Qty - 4</p>	 <p>CABLE TIE Qty x 16</p>	 <p>BATTERY LOOM S2.75</p>	 <p>Drainage pipe Qty - 2</p>	 <p>FBA Bar Qty - 1</p>
 <p>Self drilling screws Qty - 6</p>	 <p>M8 x 25mm Qty - 6</p>	 <p>M8 WASHER Qty - 12</p>	 <p>M8 SPRING WASHER Qty - 6</p>	 <p>M8 NUT Qty - 6</p>	 <p>Rear Drainage pipe Qty - 2</p>

SPECIFIC KIT H4R

 <p>50449 D-SPONGE Qty-2</p>	 <p>CL-LOOM-LONG</p>	 <p>H-PATCH</p>	 <p>Clear protective tape (30mm x 65mm) Qty - 2</p>
--	--	---	--

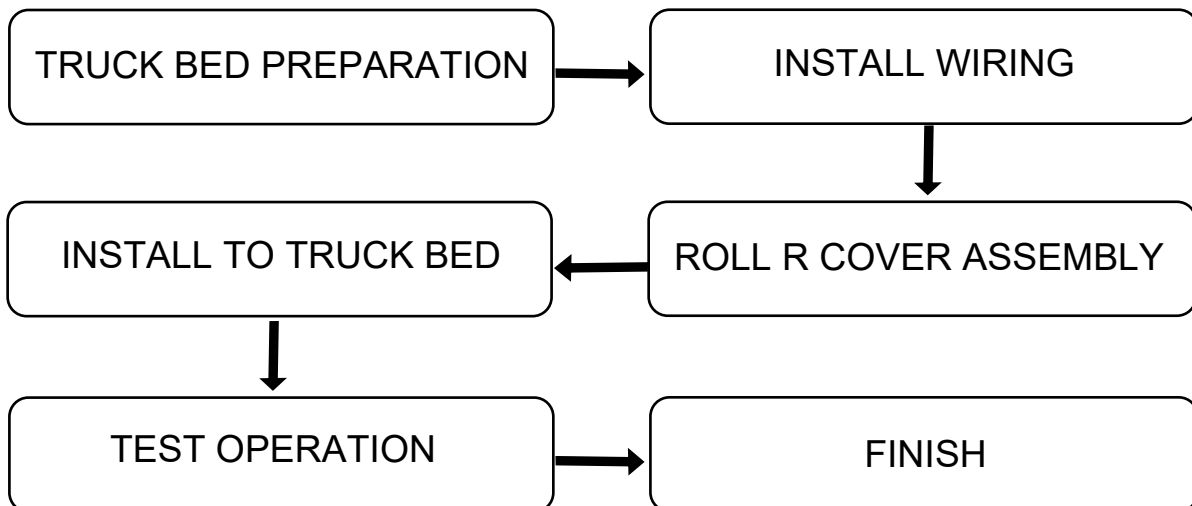

TUB PREPARATION

Clean are as indicated.

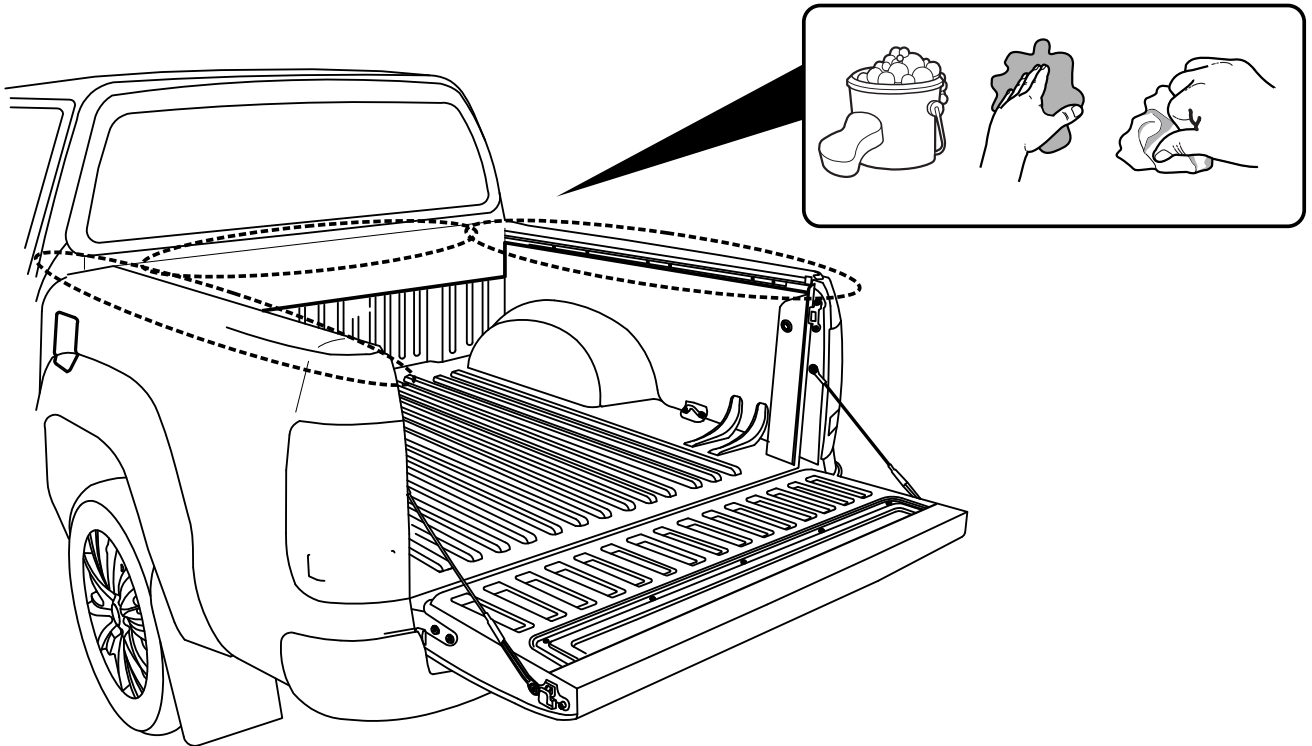

Measure 10mm down from top of tailgate and trim tailgate liner.

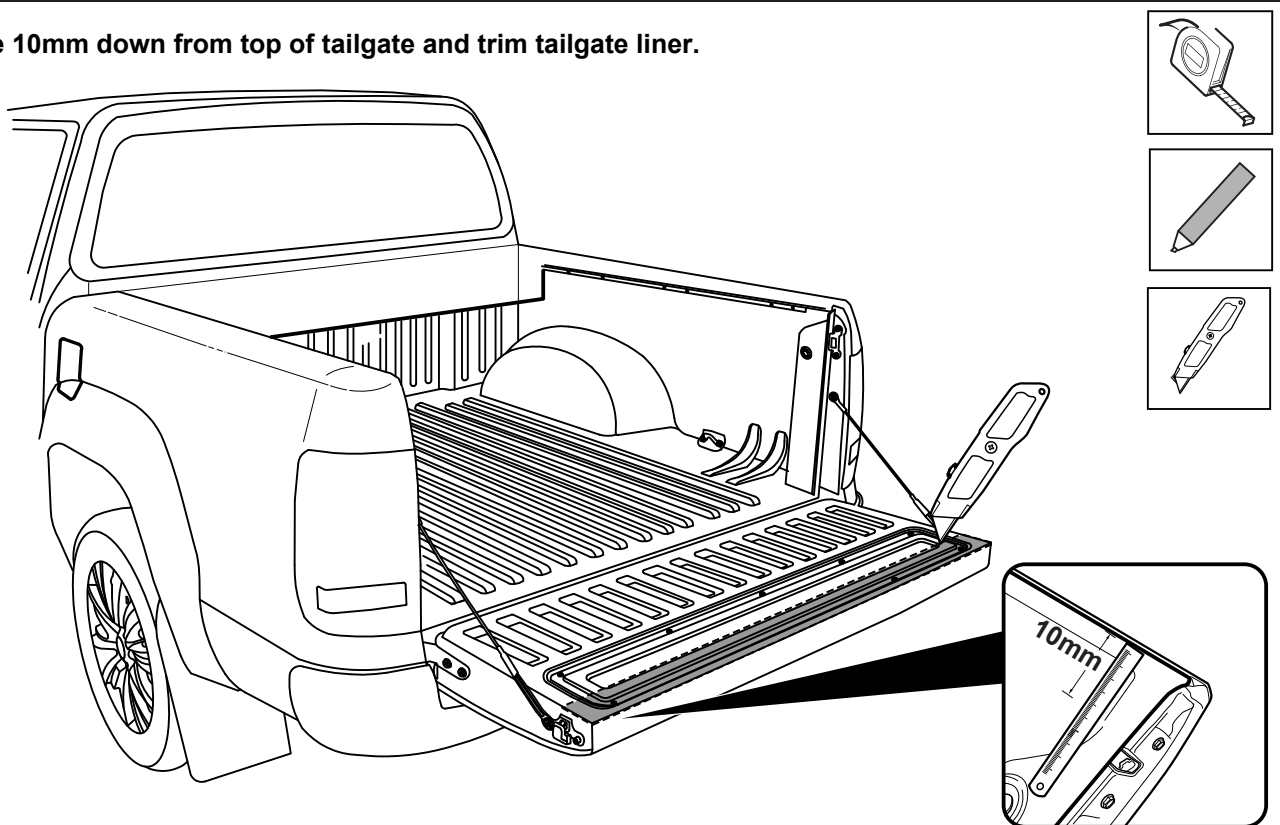

Measure 160mm down from top of Ute bed (head rail) and mark across to the other side.
Trim front of bed liner by 160mm from the top of the Ute bed as shown.

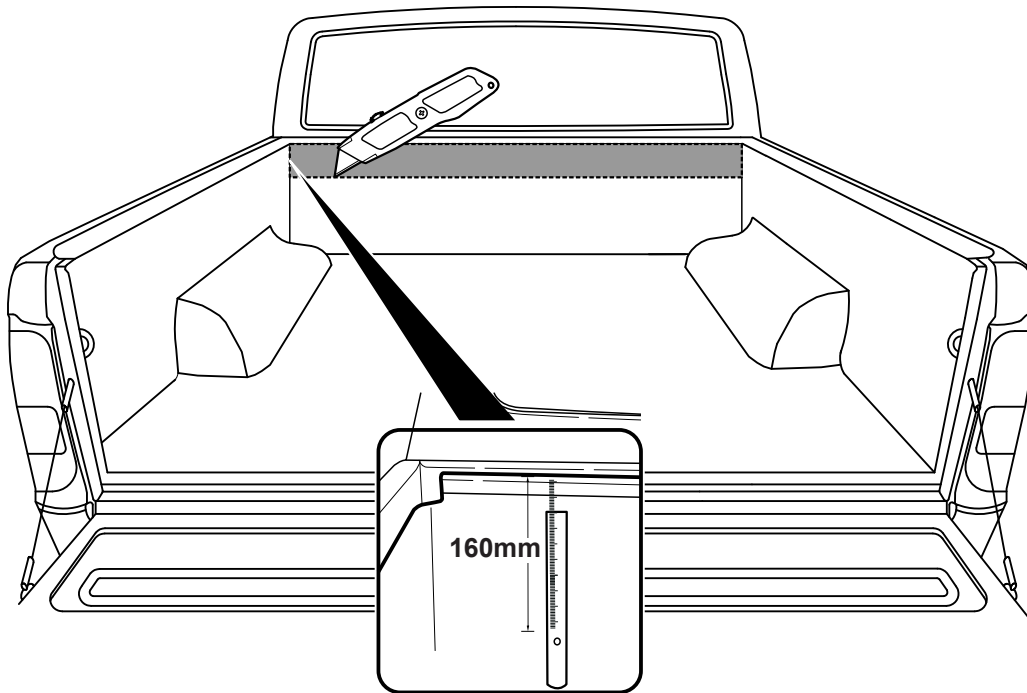

Cut a 20mm split for bed liner to flex.

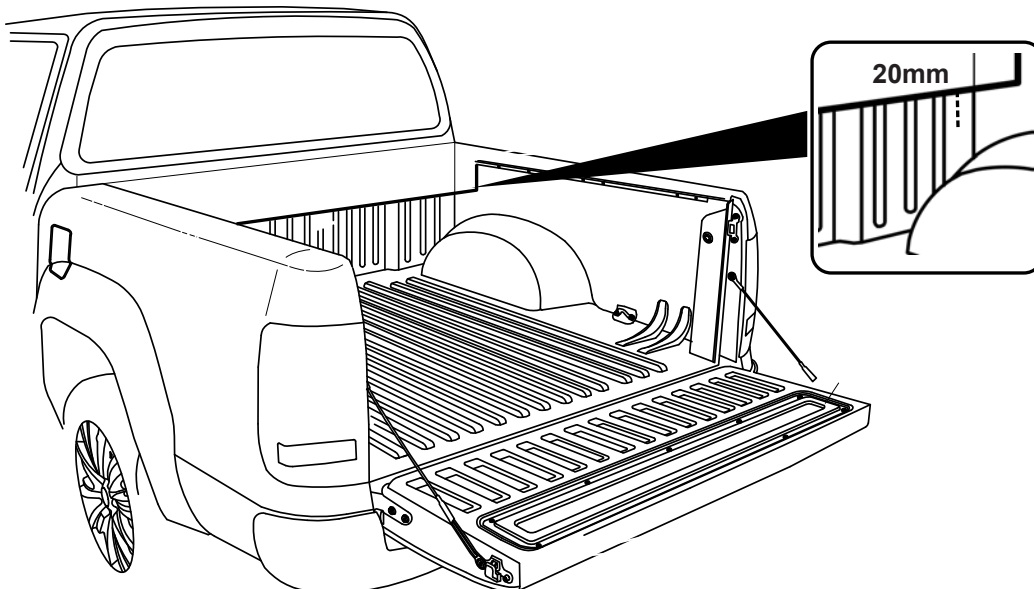

Measure down from top of assembly bar 200mm & 135 mm from inside wall of tub as shown. Repeat to the other side. Using a 50mm hole-saw drill the liner only as indicated.

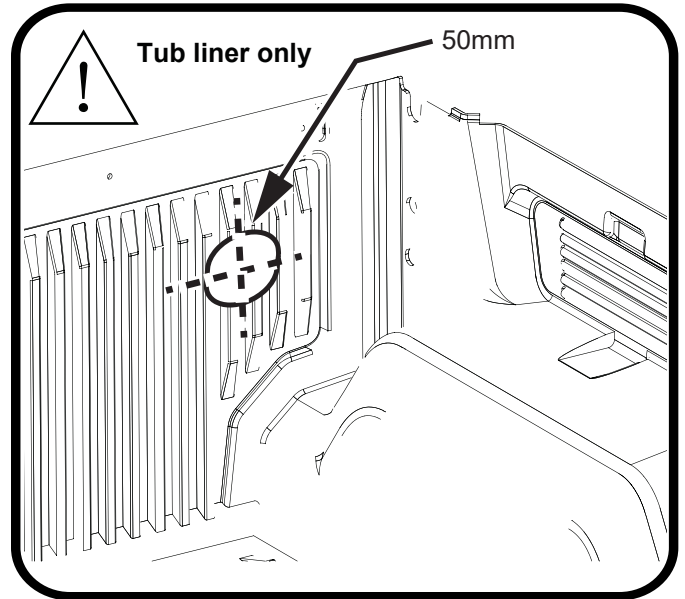
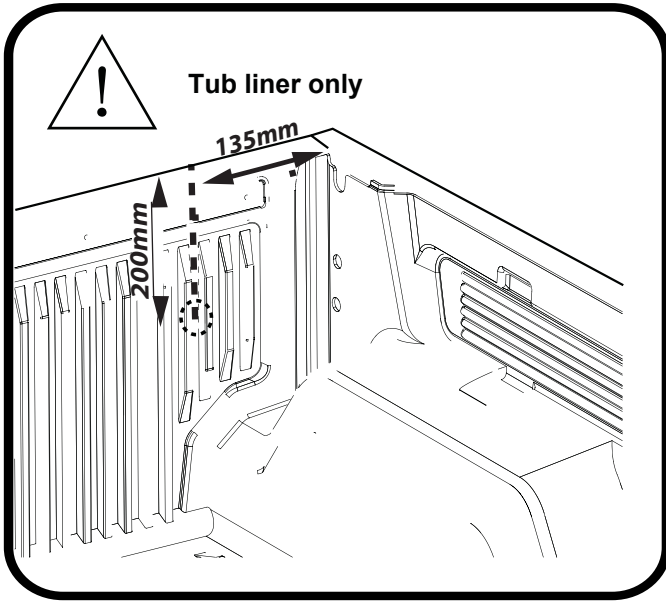
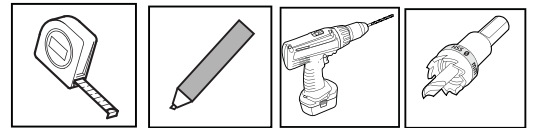

Measure down from top of headboard 200mm & 135mm from inside wall of bed as shown. (or 95mm if measuring from the side of the top rail) Repeat to the other side. Using a 30mm hole-saw drill through tub front panel, file away any sharp edges. Apply anti rust coating. Repeat to other side.

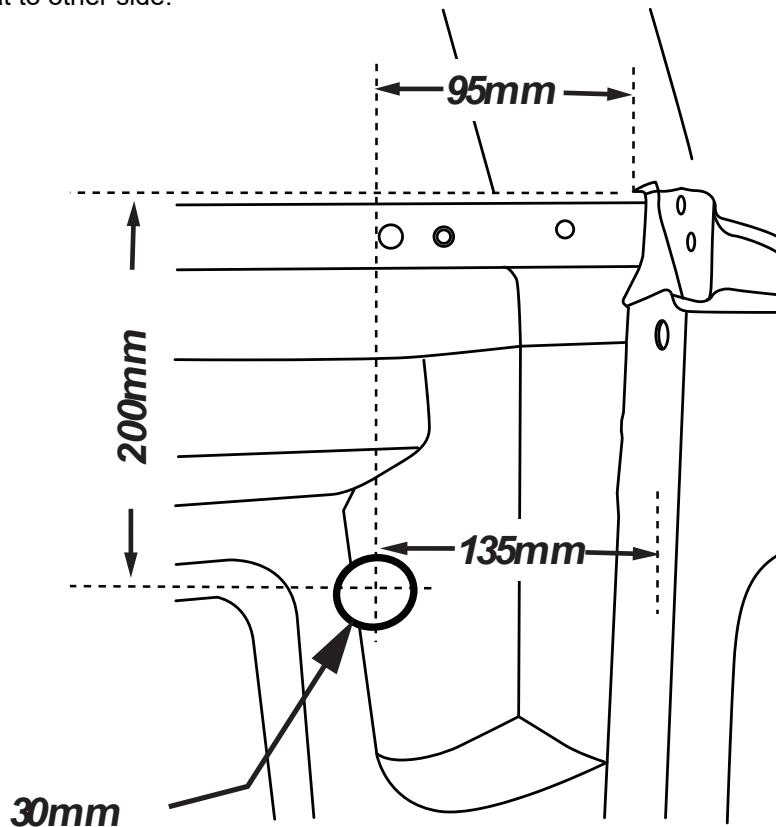
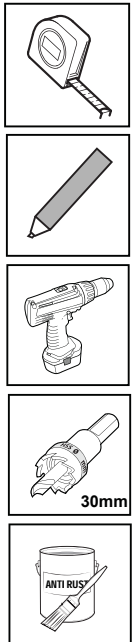

! ATTENTION: Do not exceed 30mm hole.

Seal any exposed gaps or holes on the front panel of the Ute bed with sealant.

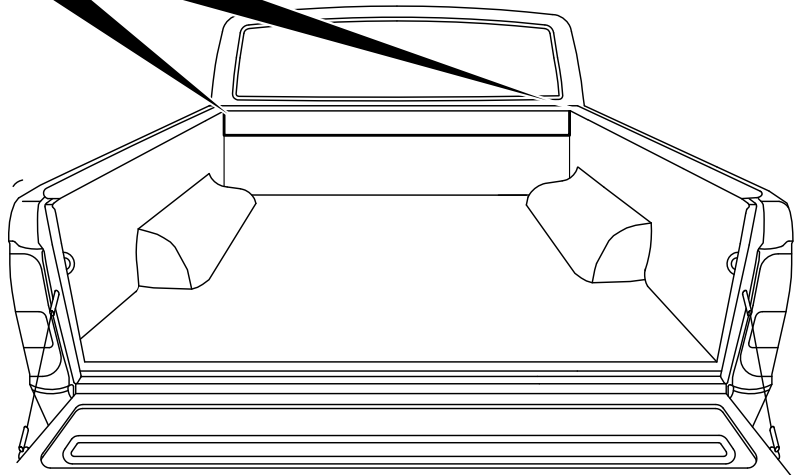
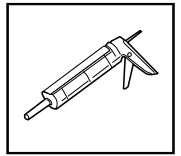
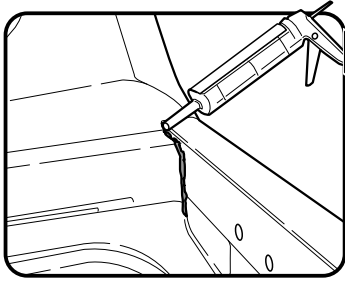

Carefully unpack the box.

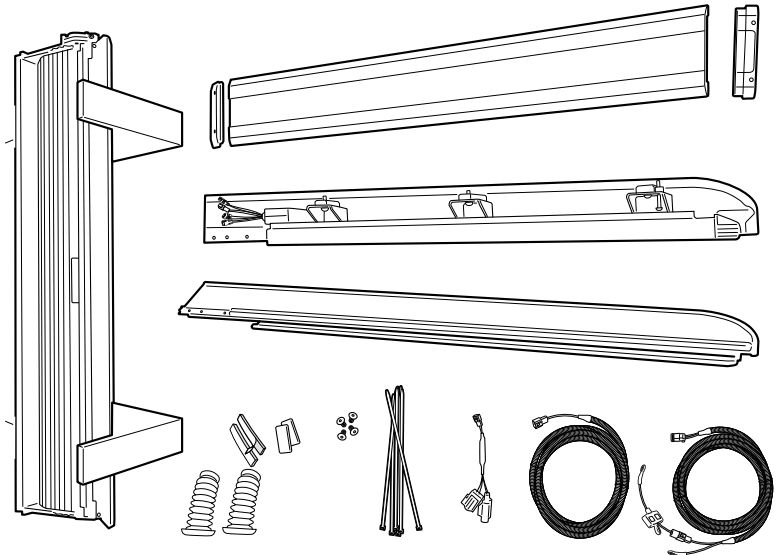
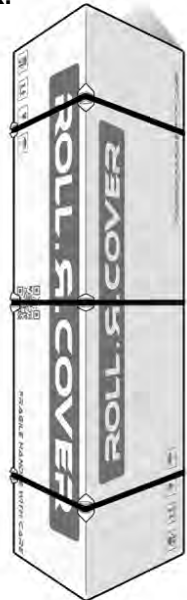

Install front drain pipes (55mm diameter end of hose) through pre-drilled holes on the front tub panel.



Note: With care push tube in.
Taking care pull the tube back so it seals correctly against the front panel of the tub.

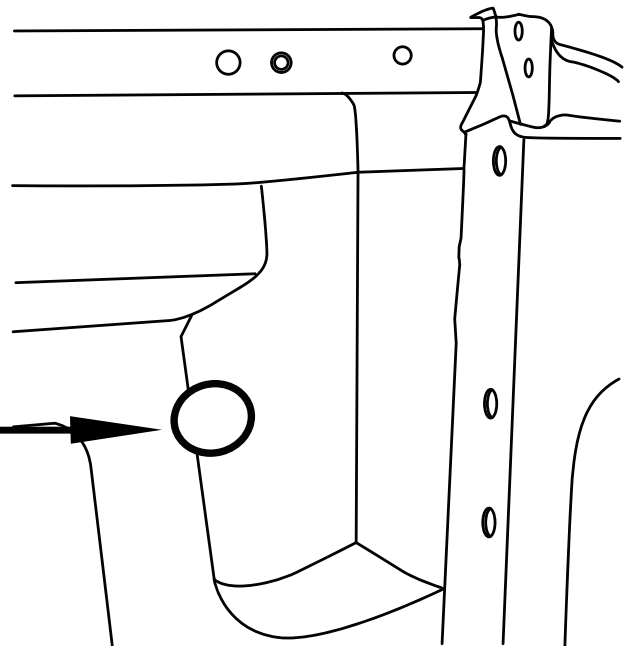
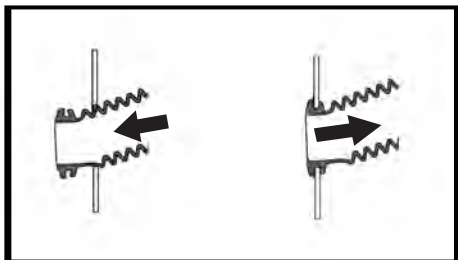

Remove and retain tail lights.

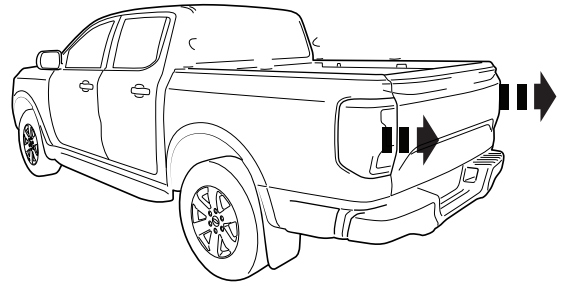

Measure 100mm towards the rear of tub from the center of the indicated factory bolt. Measure down 90mm from the indicated factory bolt as directed and make a mark.
Use a 15mm hole-saw to drill through the tub inner panel only, and file away any sharp edges. Apply an anti-rust coating. Repeat the same steps on the other side.



! ATTENTION: Do not exceed 15mm hole.

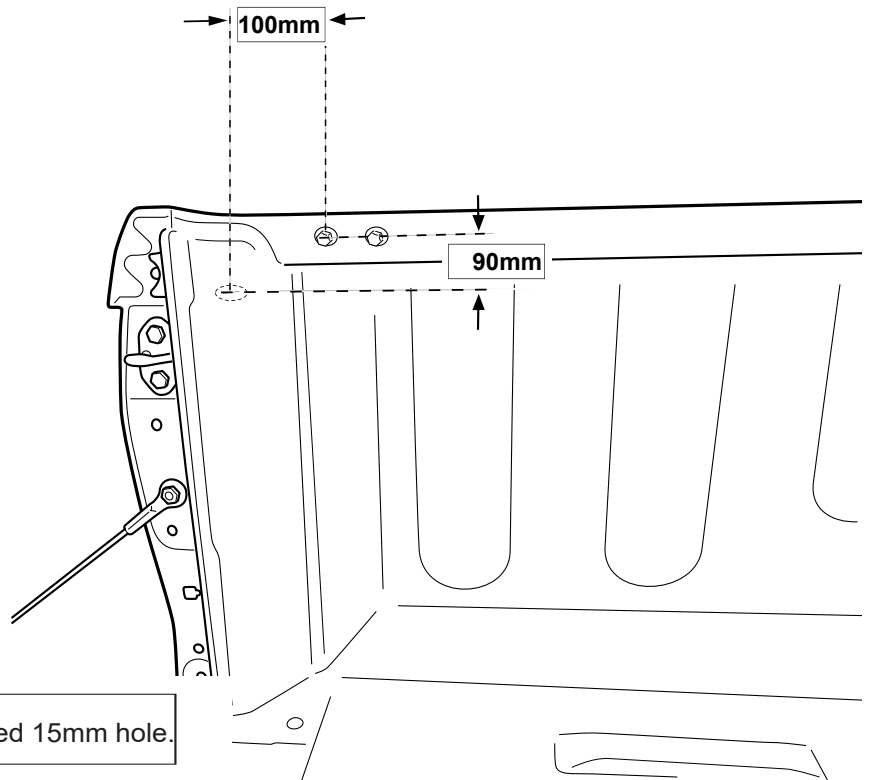

- a** In the specified orientation insert the rear drainage pipe into the previously drilled hole.
- b** Leaving 150mm of the pipe hanging out.
- c** Check the tail light cavity to ensure there are no obstructions to the drainage pipe. Repeat to the other side.
Re-fit the tail lights.

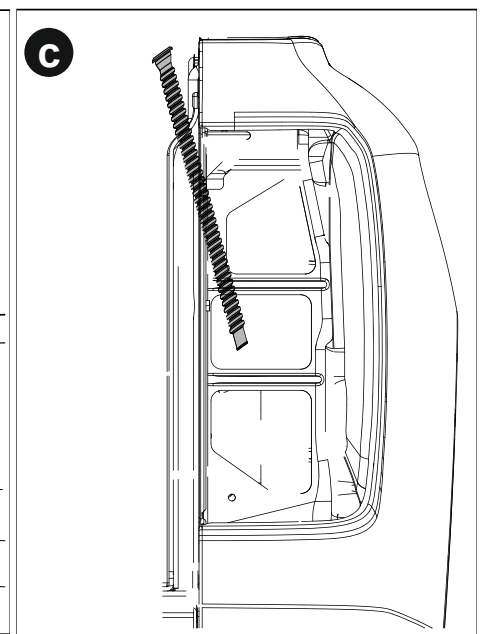
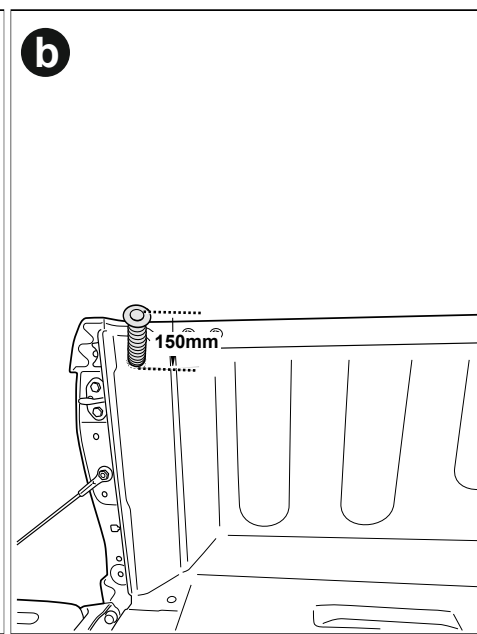
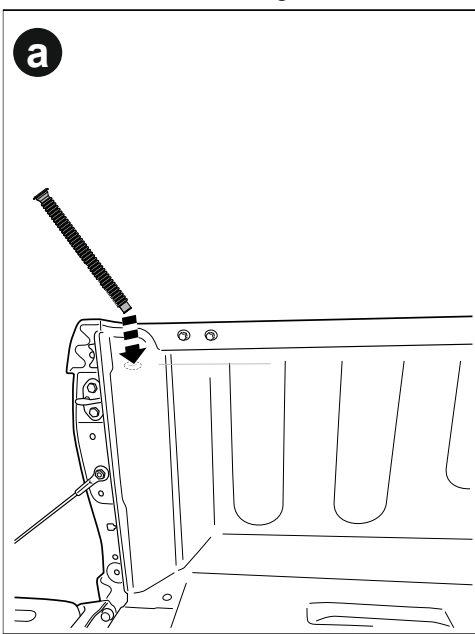

Disconnect fuse patch from battery loom S2.75.

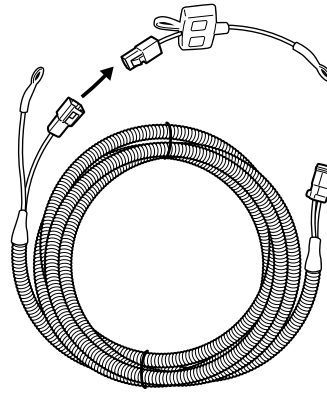

Wiring Harness steps

1 Feed Battery Loom S2.75 through the cavity

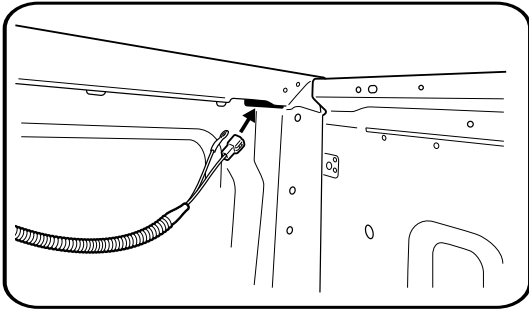

3

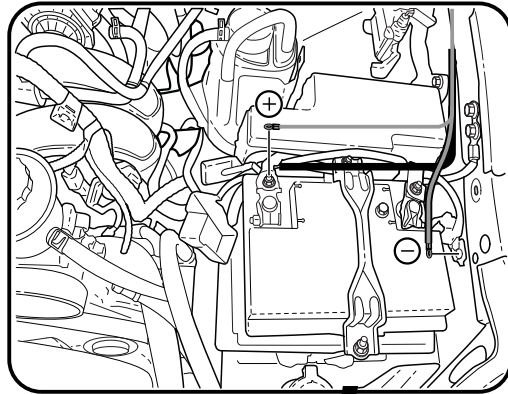

2

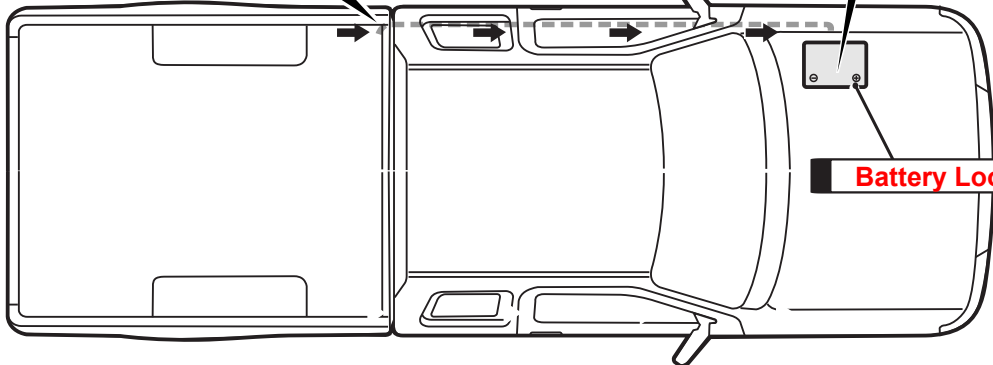

Run the wiring from the front corner cavity (leaving 200mm in the tub) to the battery over the chassis rail. Making sure to keep away from hot obstructions and cable tie every 400mm. Reconnect fuse patch to battery loom S2.75, now attach fuse patch to positive of battery and earth to the body of the Ute.

Feed CL-Short-Loom through the cavity.

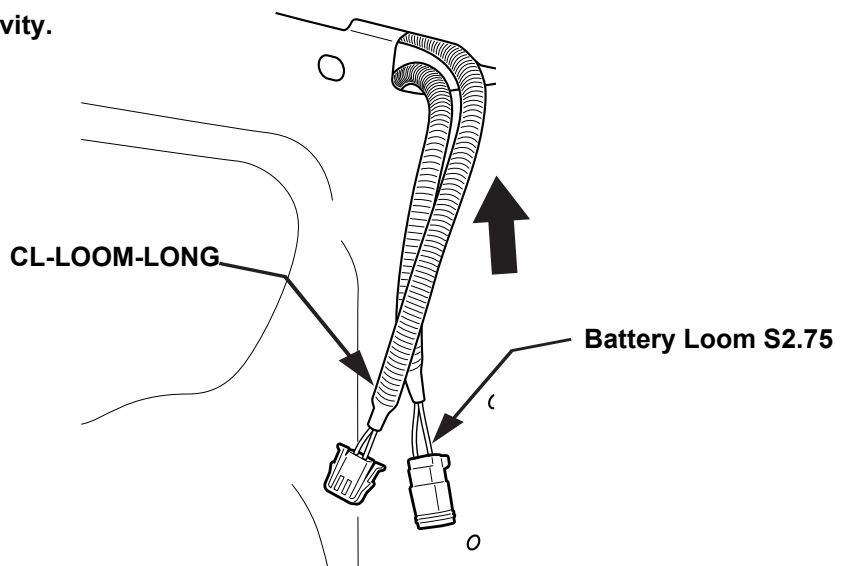

Run wiring from front tub corner cavity to passenger side kick panel. Cable tie wiring every 500mm over chassis rail. Find the large grommet on the firewall, make a small incision & run the loom through it to enter the cab and towards the kick panel. Seal accordingly.

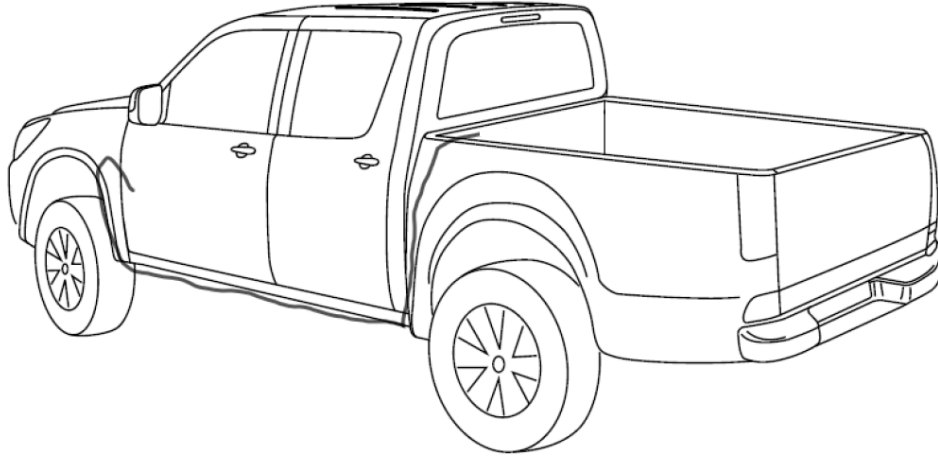

At the front passenger side foot well area:

- Remove front passenger scuff plate (1)
- Remove the kick panel trim nut (2)
- Remove the kick panel (3)

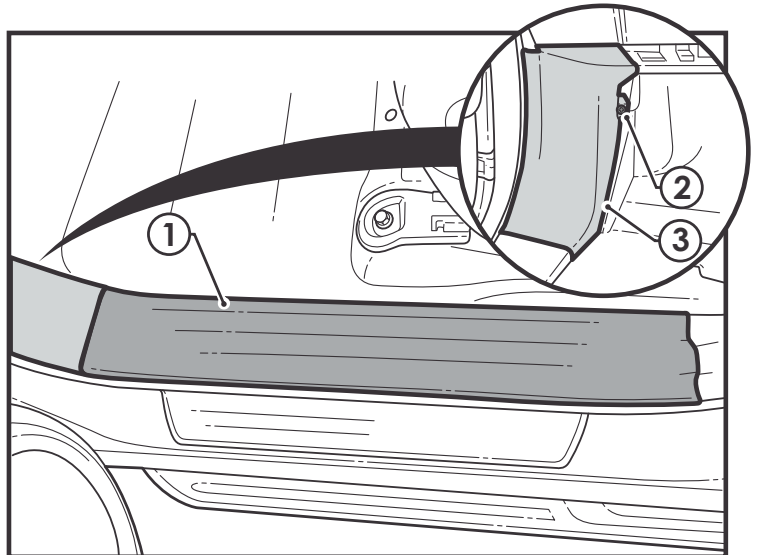

Disconnect 20 way connector as indicated.

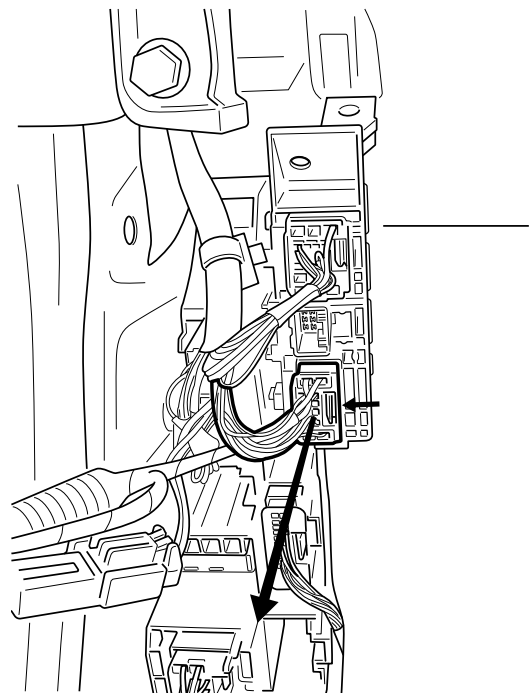

1. Connect H-patch 20 way male connector to vehicle's female housing.
2. Connect vehicles 20 way connector to H-patch female housing.

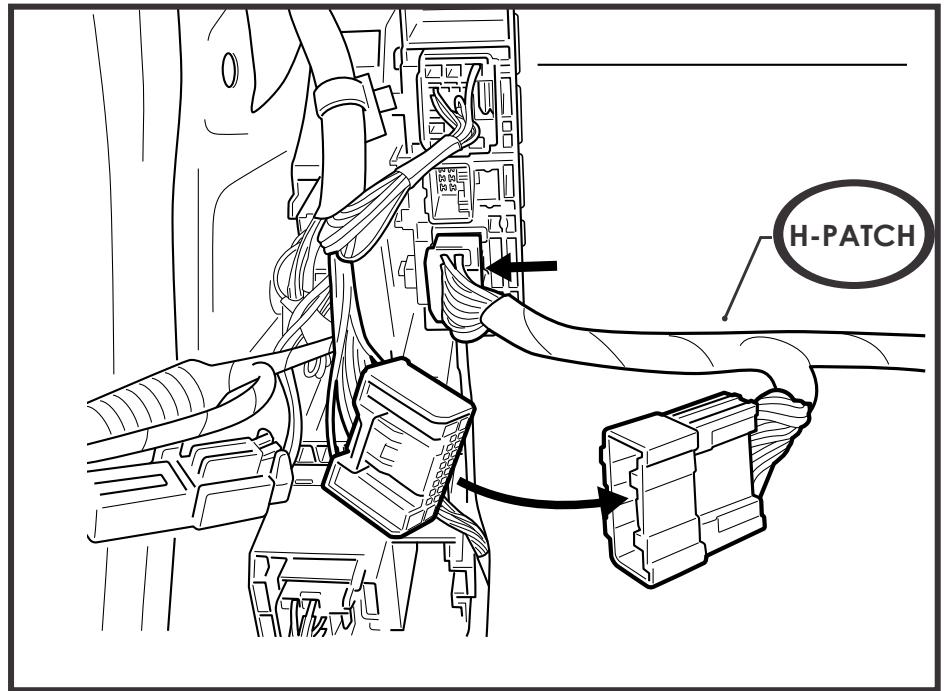

Connect H-PATCH loom to CL-LOOM-LONG

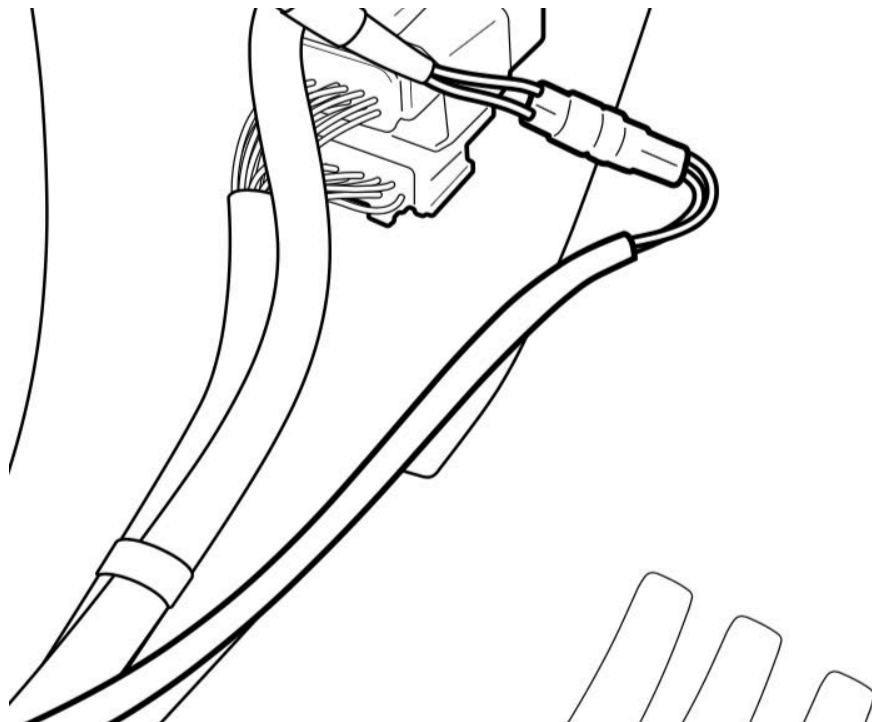

keep the cannister in the foam blocks from the packaging for assembly.

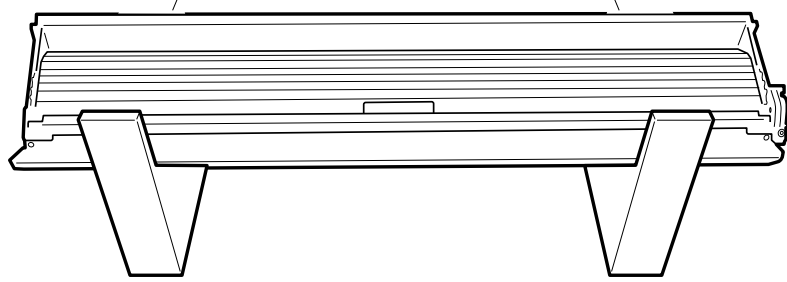

With assistance turn the canister on its back on the foam blocks.

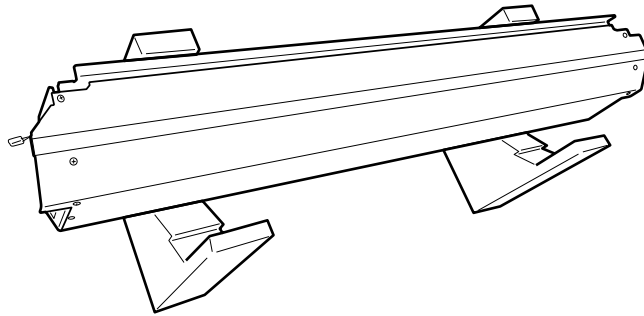

Disengage motor from the axle by unfastening the 3 Screws as indicated. Retain all parts.

Remove and retain the 3 screw from the canister as indicated.

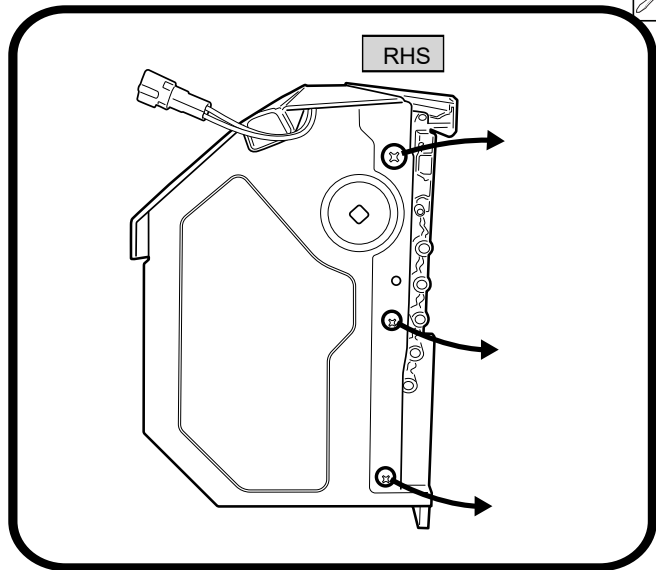
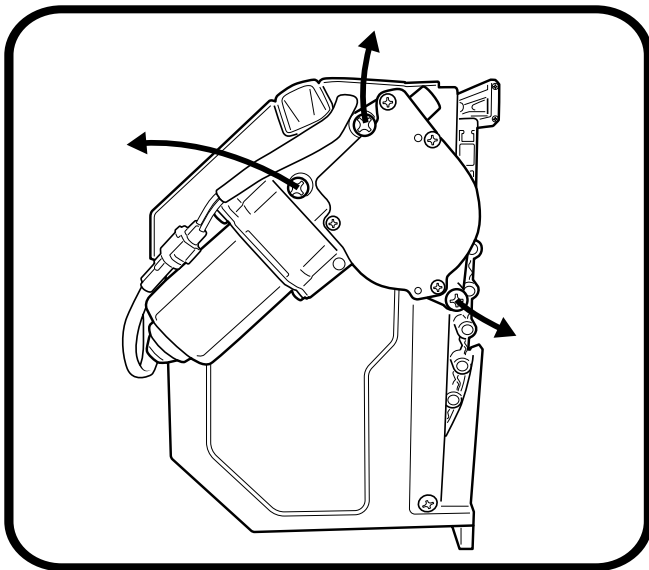

Now on the other side, remove and retain the 4 screws from the canister as indicated.

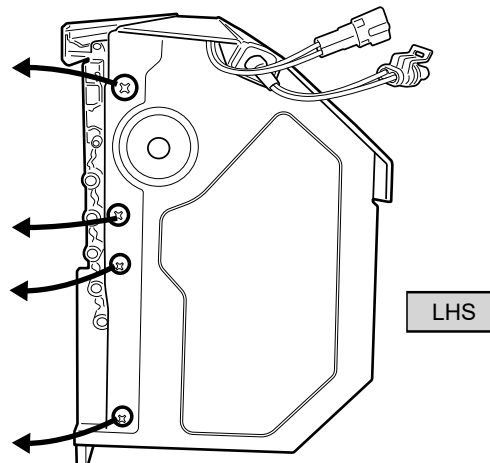
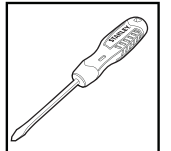



Important Note: Ensure that the Z seal within the track is positioned over the curtain and not folded inward. **WARRANTY** voided if assembled incorrectly.

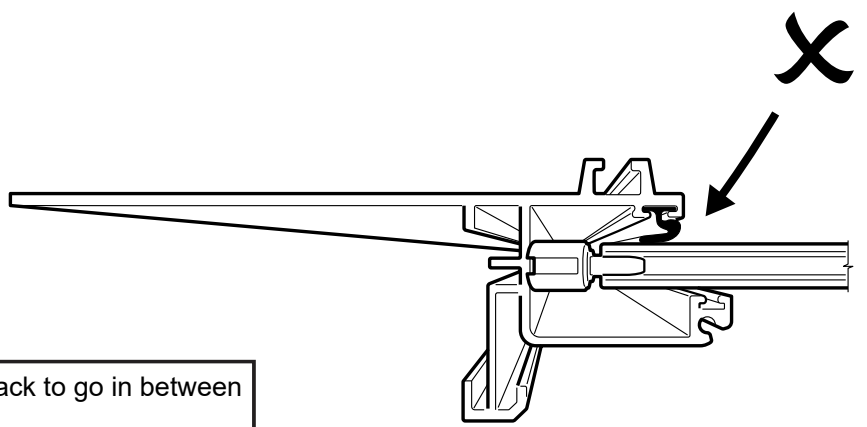
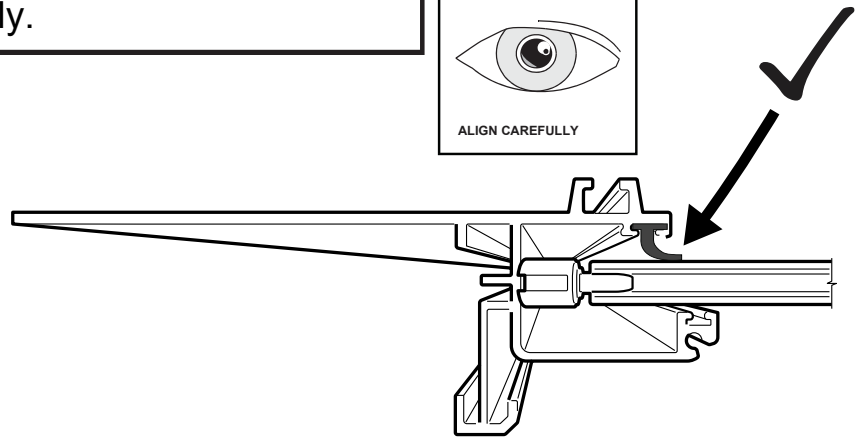
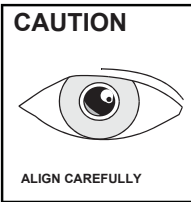

 **VISUAL TIP**

Align side rail to side of canister, guide the track to go in between the curtain end rubber stop.
NOTE: LHS side rail to be assembled first.

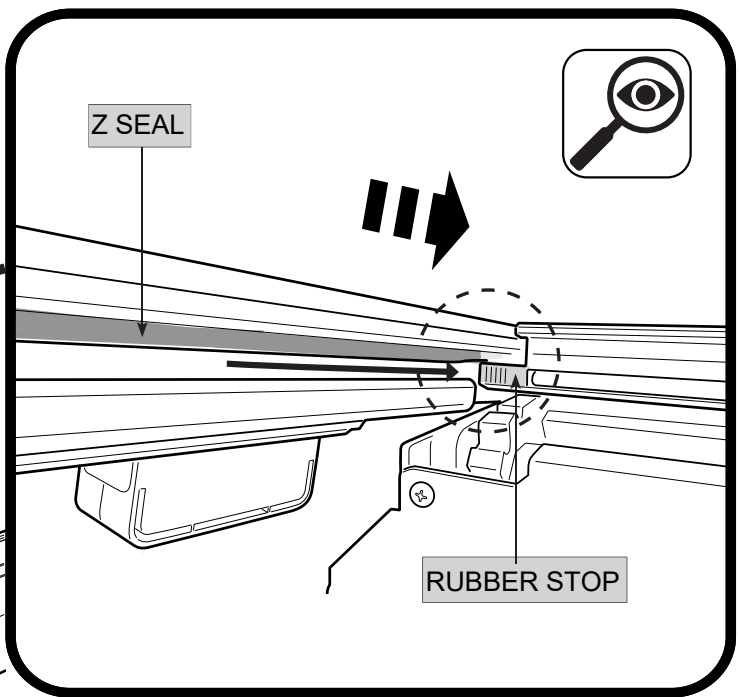
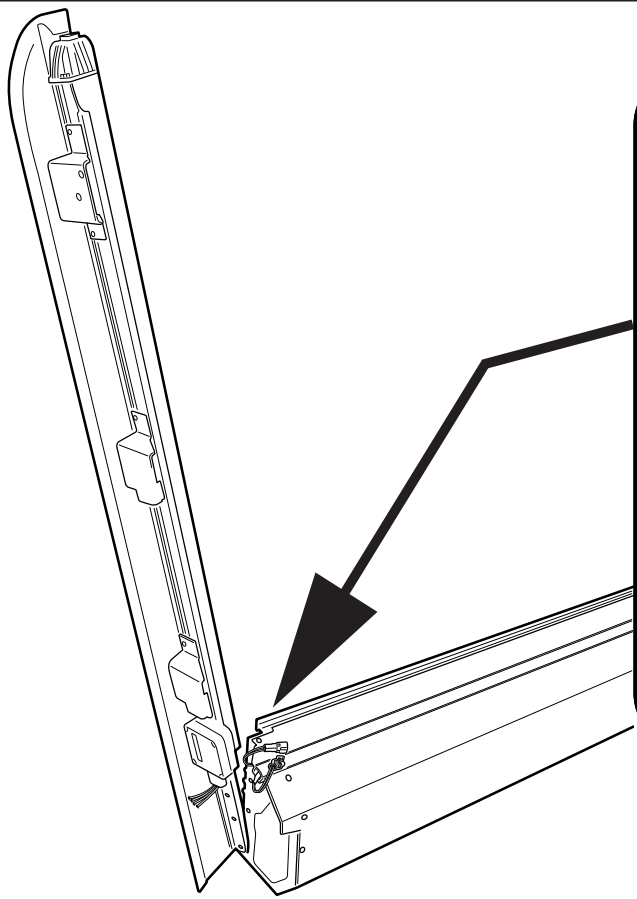

1. Using the retained screws, spring washer and washer, Loosely fasten the side rail to the location indicated.
2. Side rail edge must compress and meet with the canister profile as indicated below.
3. Fasten all screws tight.

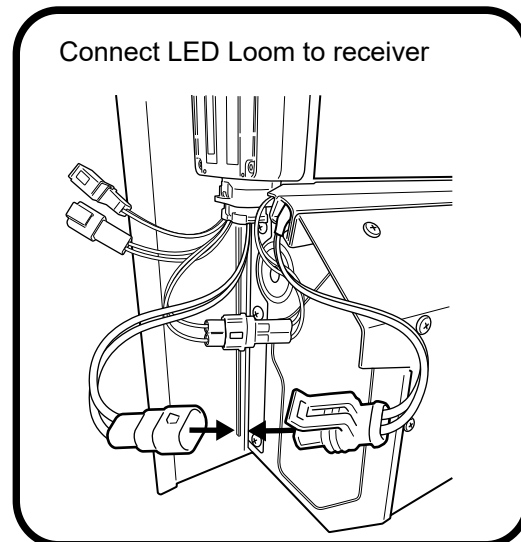
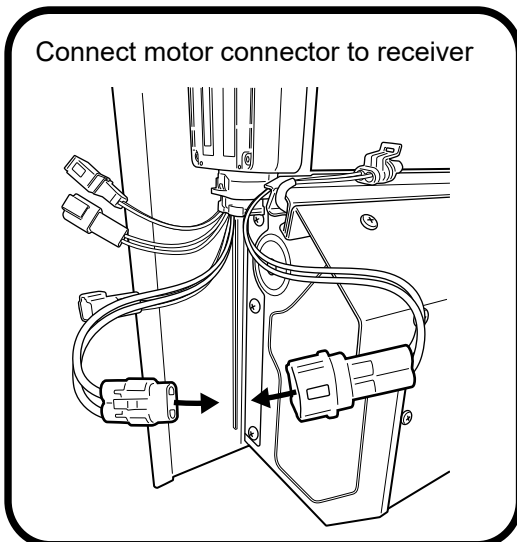
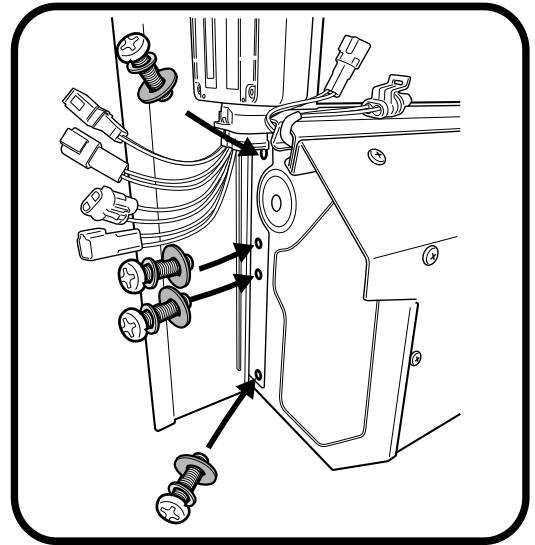
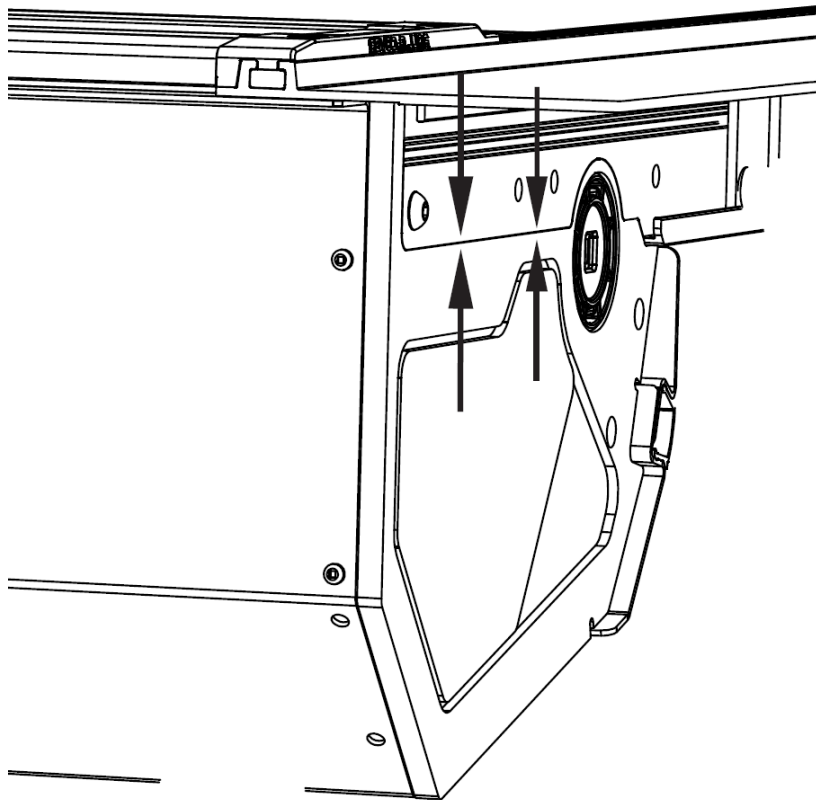
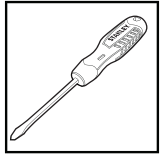



Important Note: Ensure that the Z seal within the track is positioned over the curtain and not folded inward. **WARRANTY** voided if assembled incorrectly.

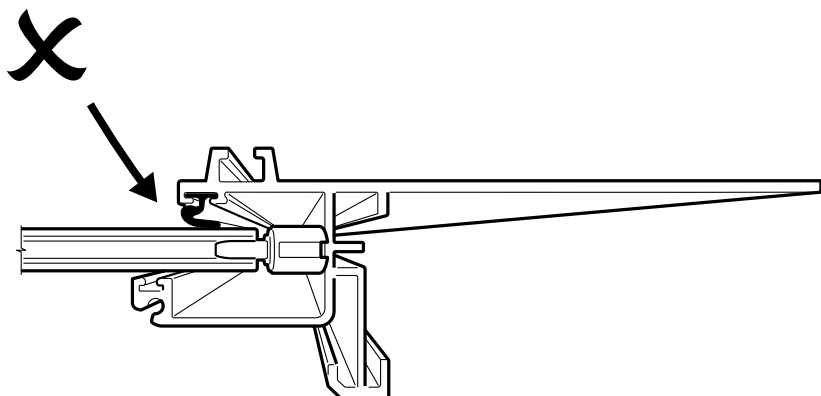
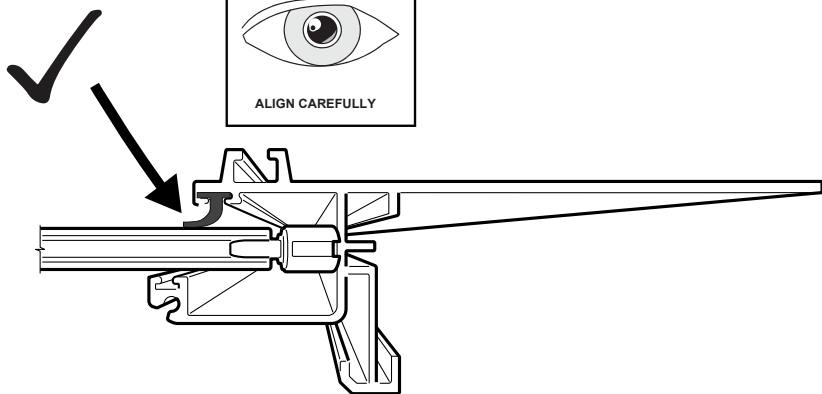

Align side rail to side of canister, guide the track to go in between the curtain end rubber stop.

NOTE: LHS side rail to be assembled first.

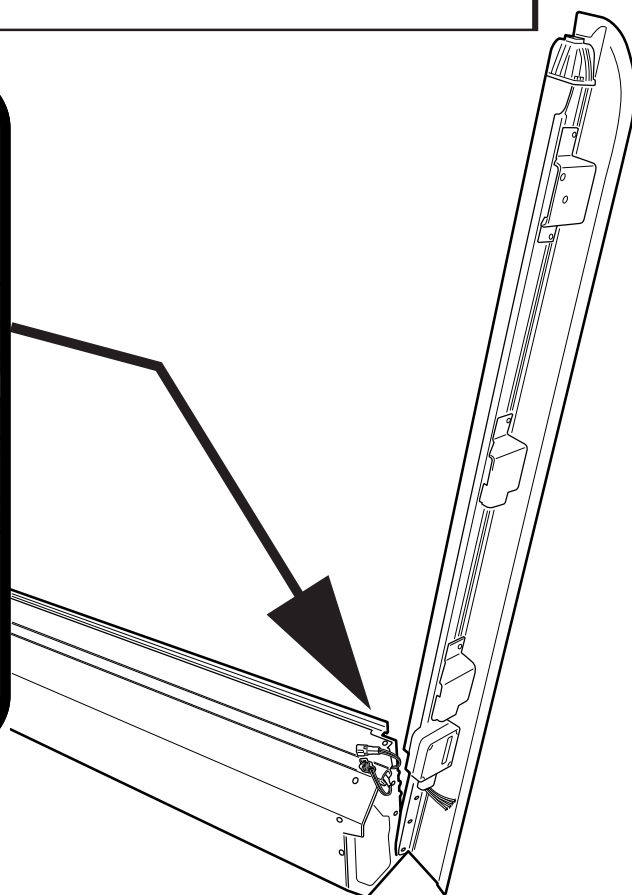
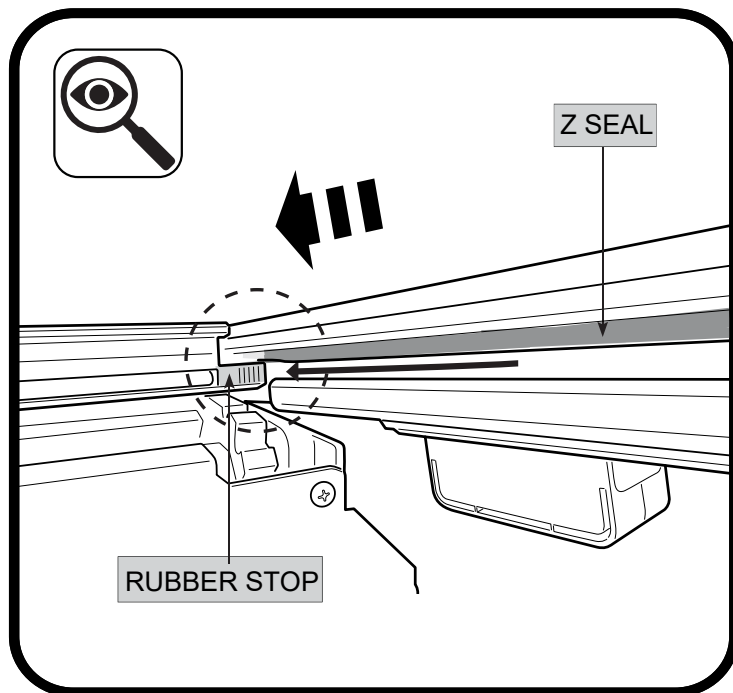

1. Using the retained screws, spring washer and washer, Loosely fasten the side rail to the location indicated.
2. Side rail edge must compress and meet with the canister profile as indicated below.
3. Fasten all screws tight.

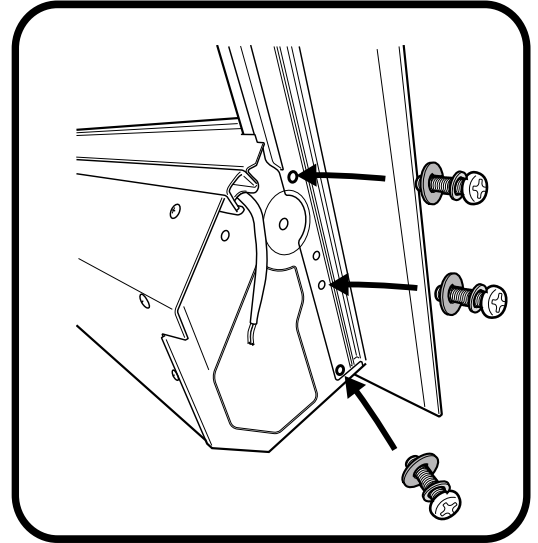
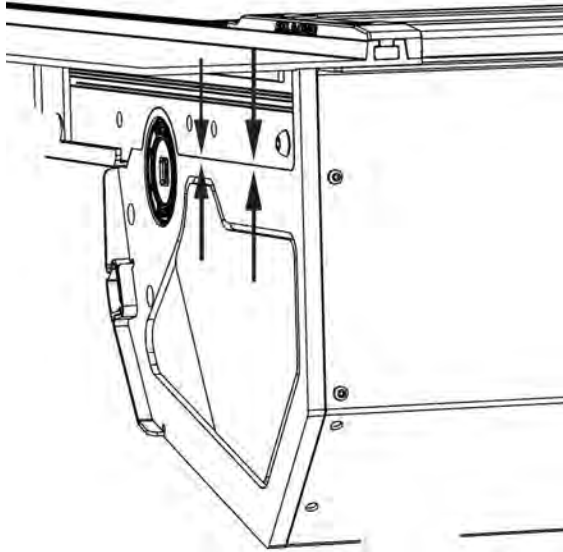
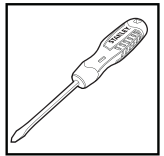

Feed M6 bolt through spring washer, motor and rubber bush.

NOTE: Rubber bush orientation has to be as per image. (side with text on rubber, to face the motor).

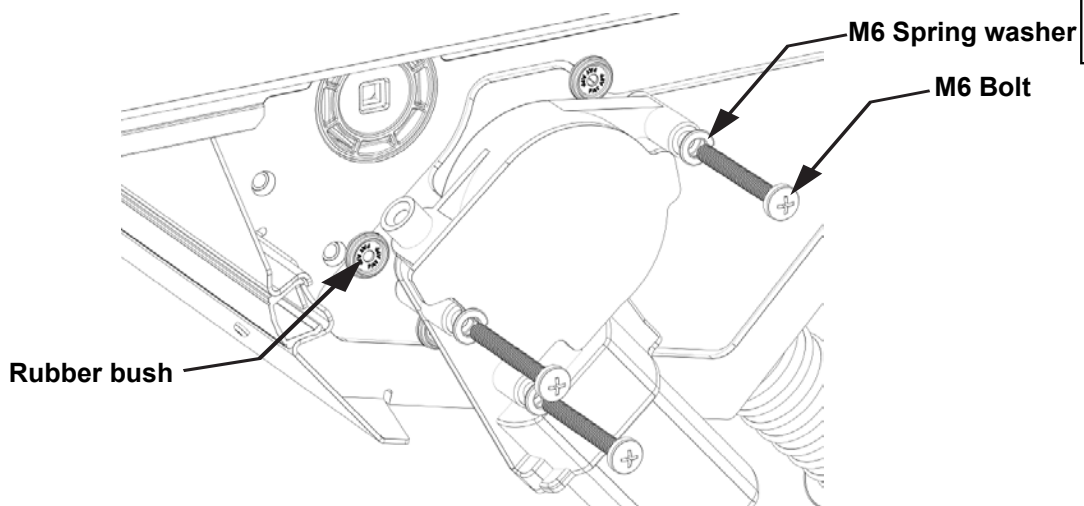
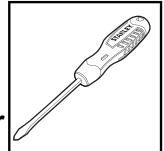

Align & insert motor shaft to axle.

NOTE: Pull / push curtain for axle to rotate.

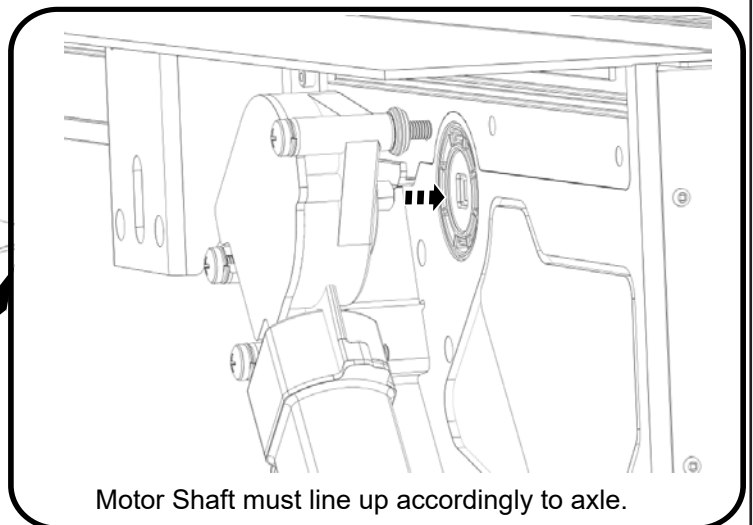
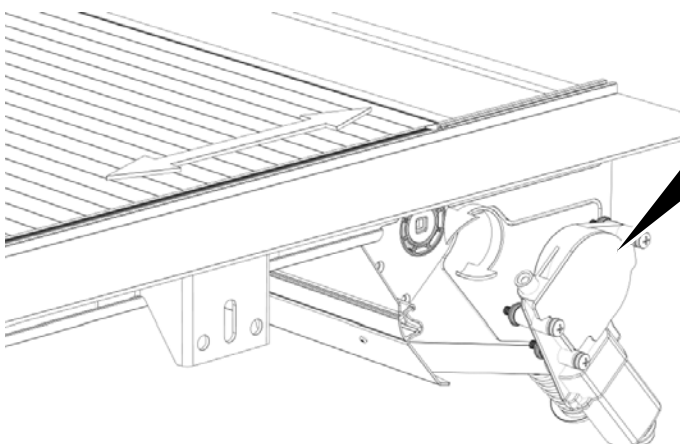

Motor Shaft must line up accordingly to axle.

Fasten all 3 screws to 2nm torque. Over tensioning will cause operating issue's.

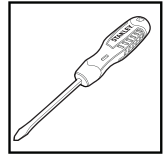
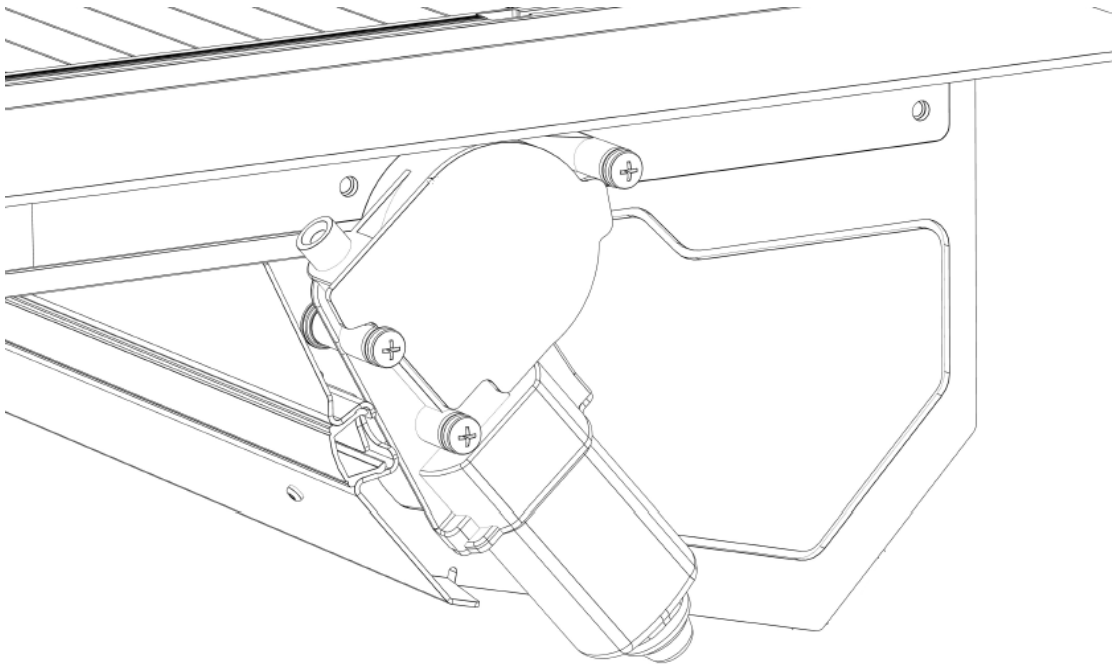

Motor is to sit level.

Any obstructions between motor and canister may cause operating issues.

Apply 15mm foam tape to side rail as indicated. NOTE: Join foam firmly to the per-fitted foam of the canister. Carefully trim excess off & discard as indicated. Repeat on the other side.

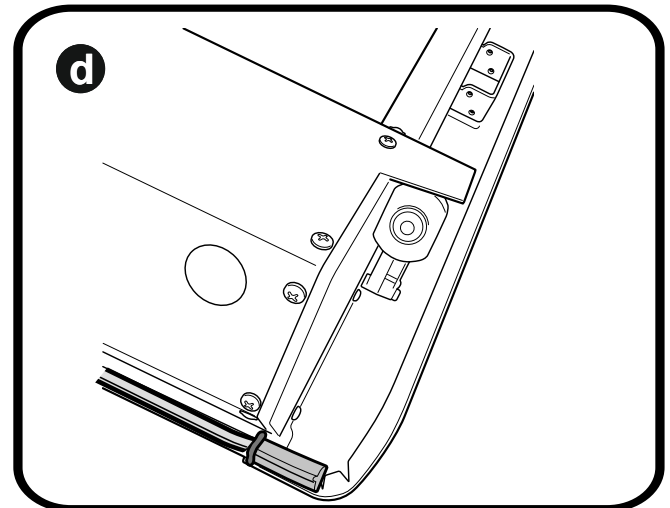
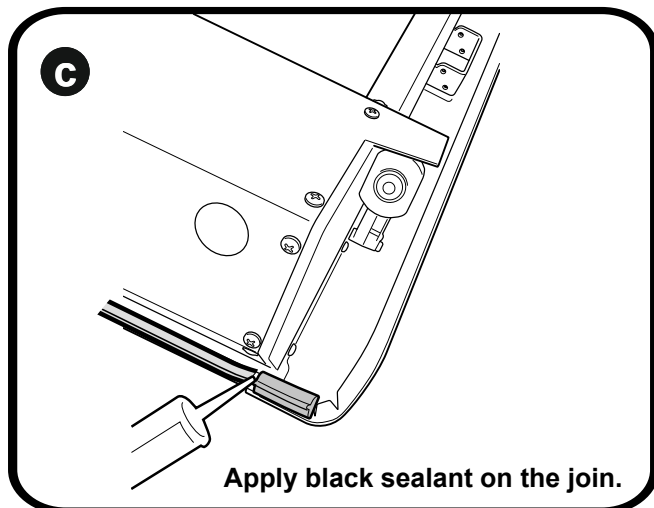
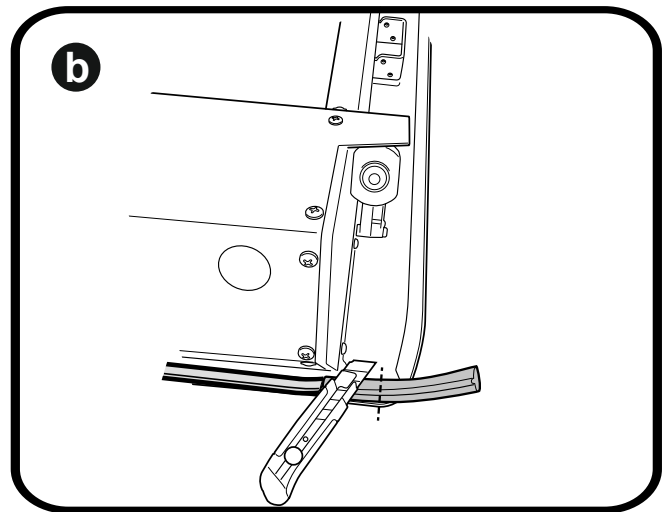
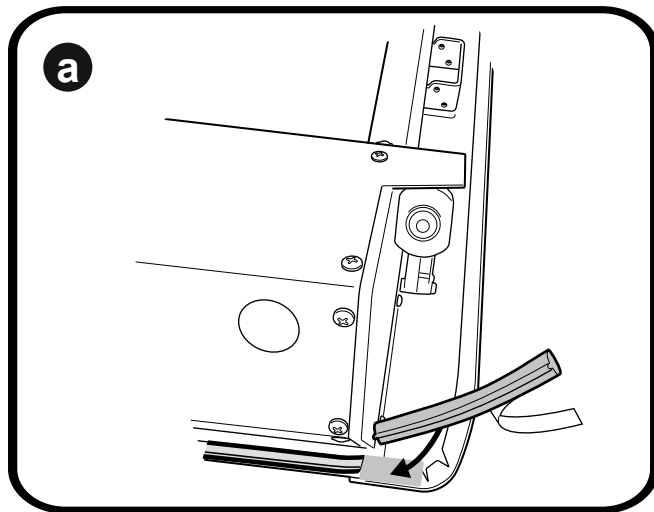

Carefully bring down the assembled unit.

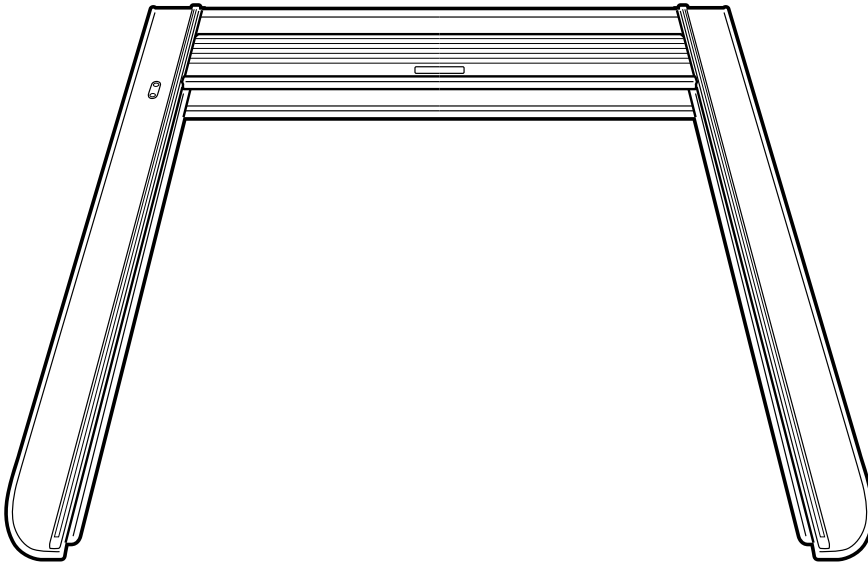

Insert side end caps to the top cover.

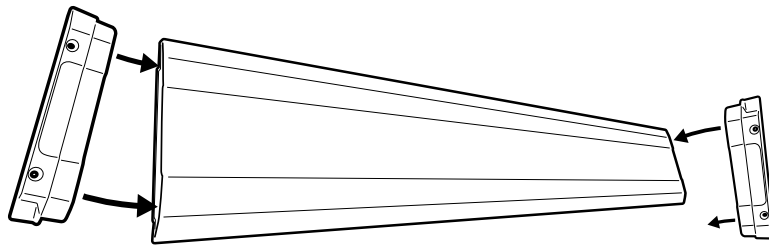

Place & Align top cover over the canister and side rails.

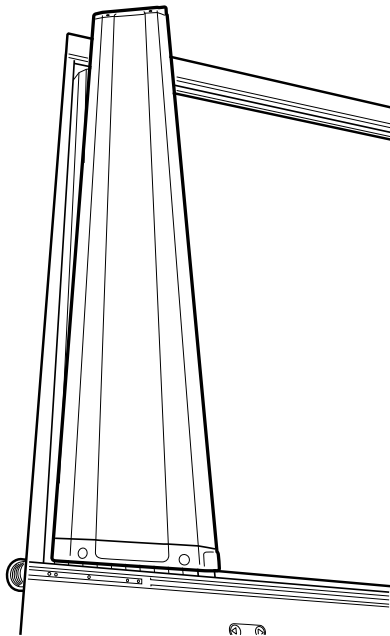

Using countersunk screws provided, line up end cap holes to the threads on the side rail. Fasten to 3nm torque. Repeat to the other side.

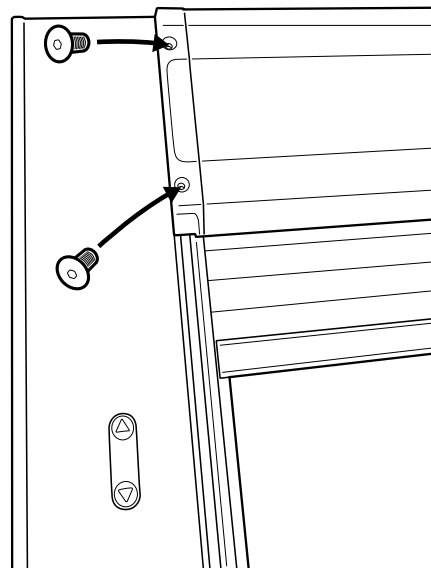

Align the front bar assembly along the front of the tray ensuring that the bar is centered. Attach FBA using the self-drilling screws [supplied] through the holes pre-drilled in the front bar making sure the top is level with the side of the tub.

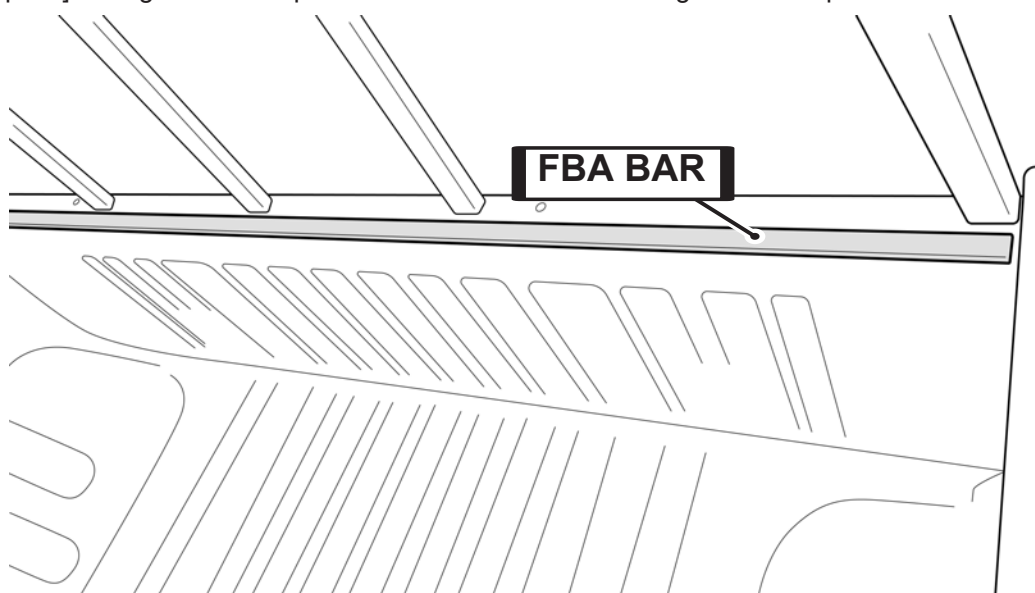

Place the Roll-R-Cover unit on to Ute bed.

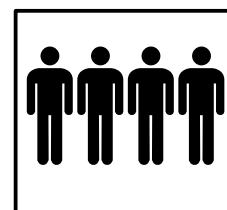
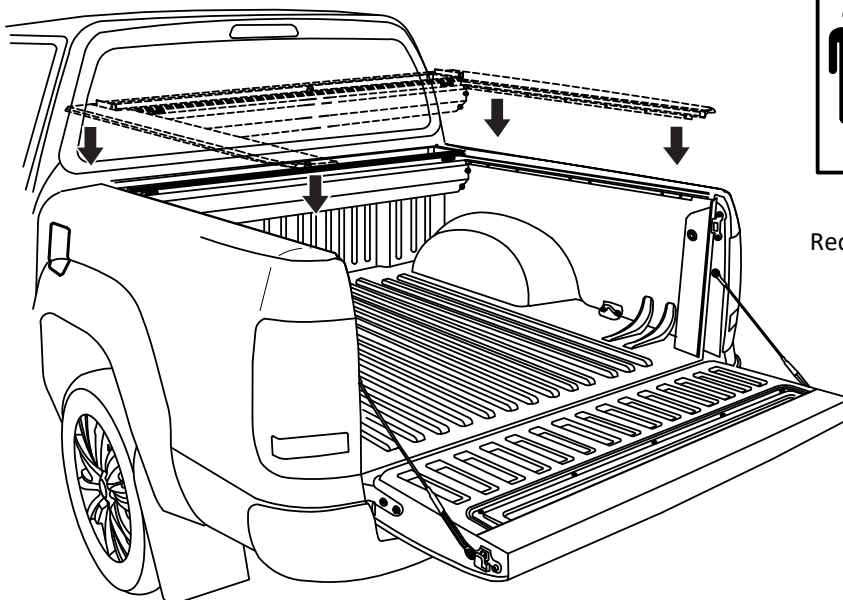

4 People
Recommended for lift

With care, pull out any side rubber that has folded under the side rail.

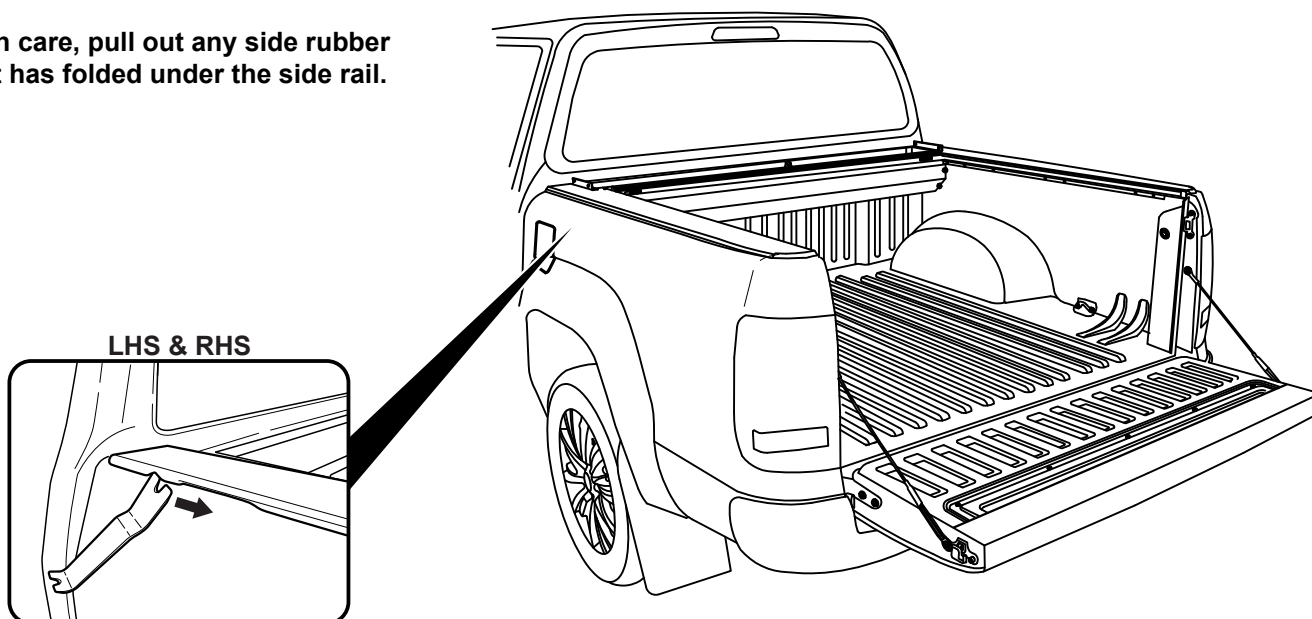

With the tailgate up (Closed position), Pull left & right hand side rails towards the tailgate, stopping short by 5mm between tailgate and side-rail end-cap.

5mm

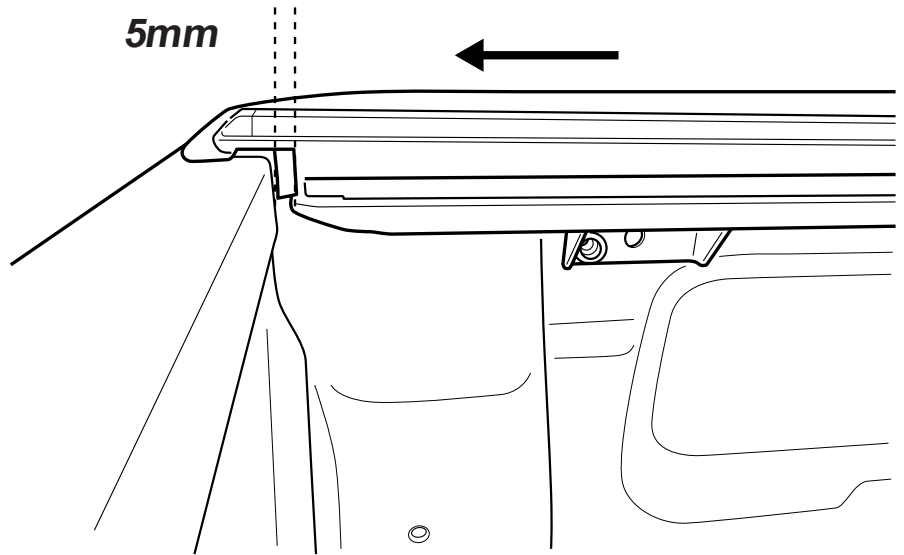

Foam compressed to 5mm when tailgate is closed.

Gap between tailgate and side-rail end cap to be 5mm.

Foam seal

Side rail end cap

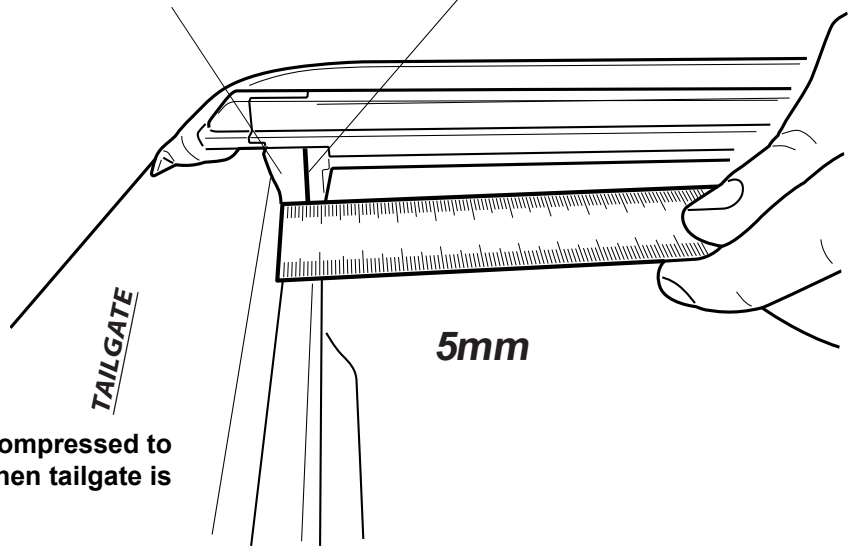

5mm



Foam compressed to 5mm when tailgate is closed.

Locate side rail tabs that are resting against the side of tub, mark through the per-drilled holes on the tabs. Repeat for all 6 tabs.

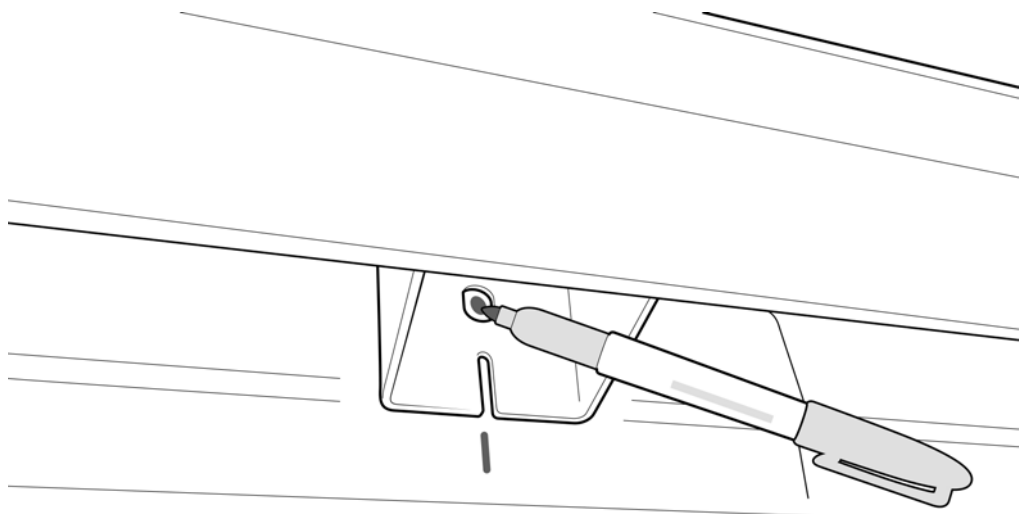

NOTE: If the ute is equipped with a tub liner you will have to trim the liner around the side rail tabs. (the side rail tabs must be resting on the tub body only).

Remove Roll R Cover from the tub.

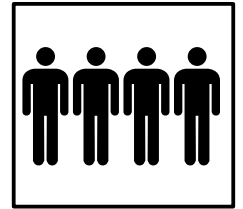
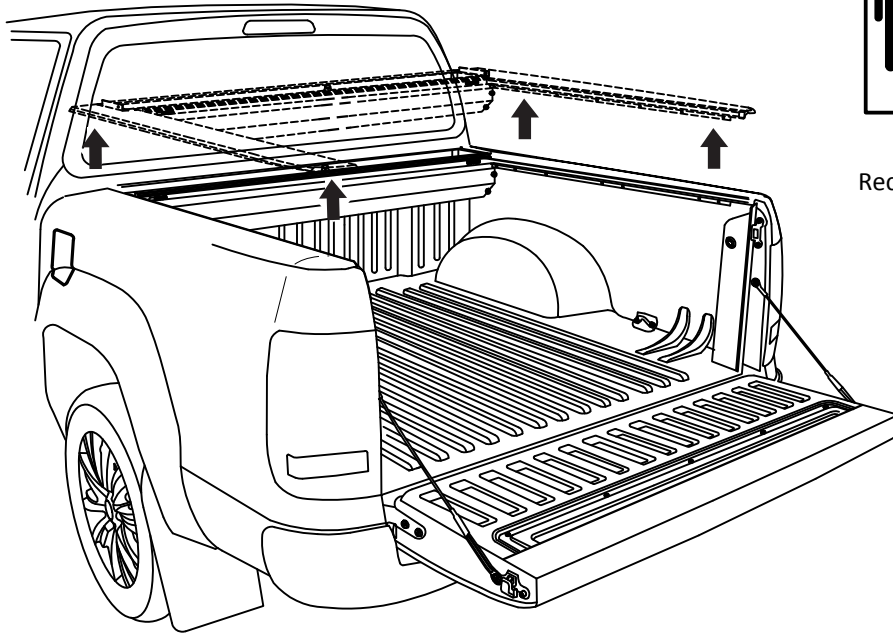

4 People
Recommended for lift

Drill through pre-marked holes using 9mm drill bit.

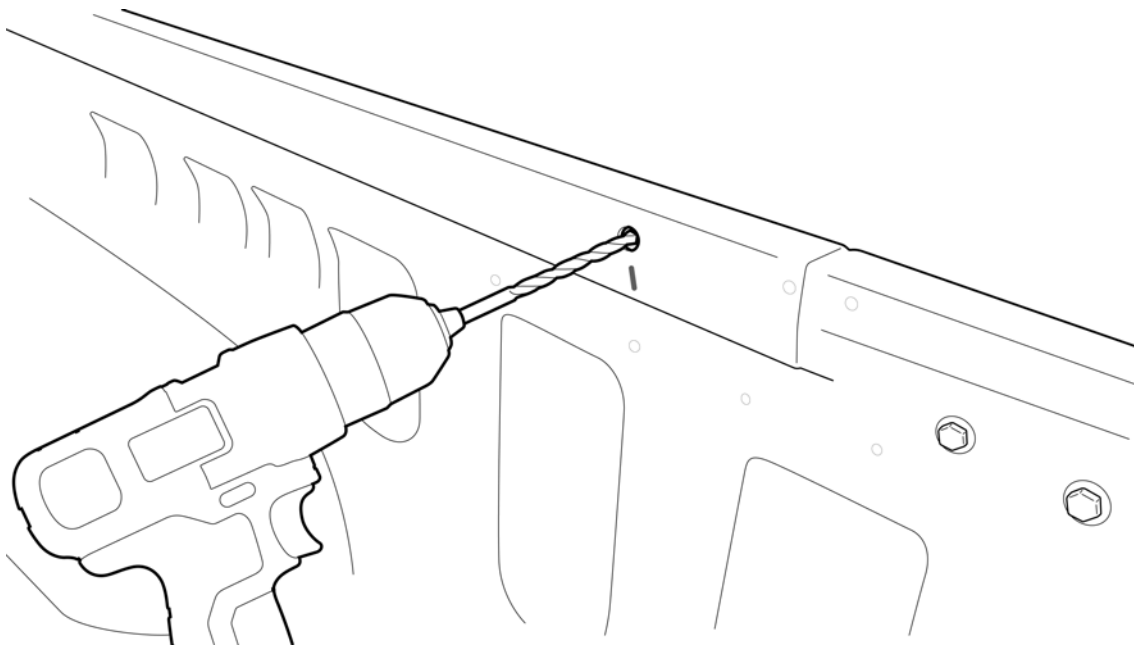

NOTE: Apply anti rust coating. Repeat to all 6 holes.

Place the Roll-R-Cover unit on to Ute bed.

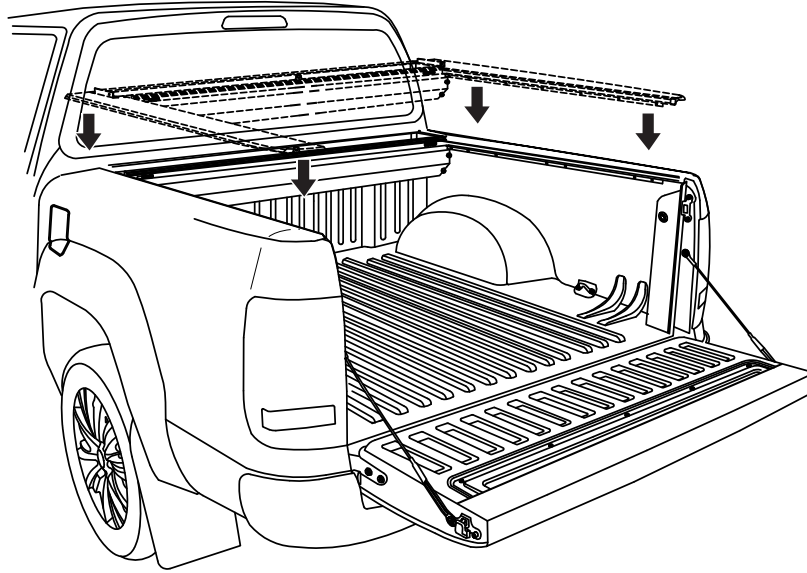

4 People
Recommended for lift

A

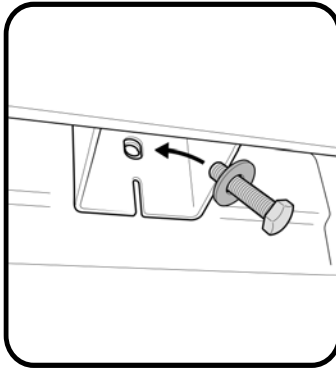

Feed M8 Bolt and flat washer, through side rail tab

B

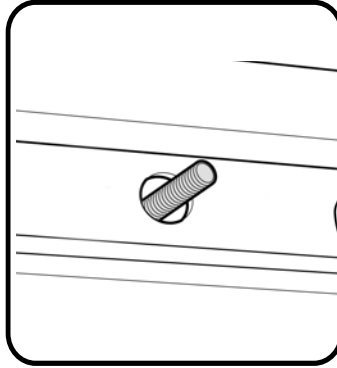

View from outside of tub.

C

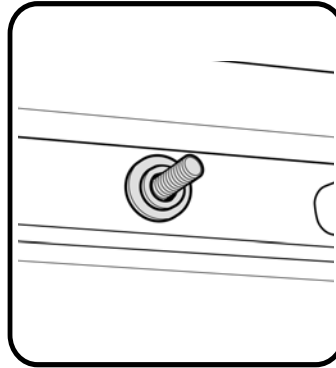

Place flat washer and spring washer over bolt.

D

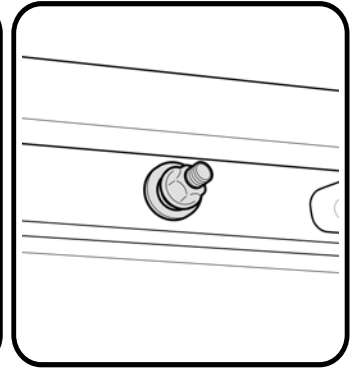

Place M8 nut to M8 thread.

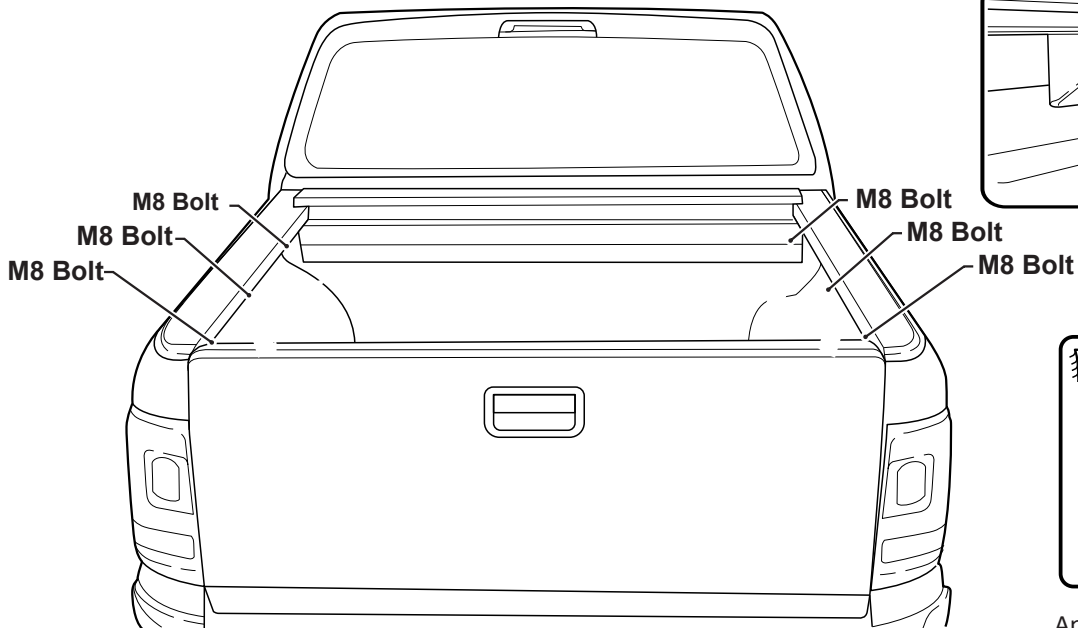

Apply slight pressure then tighten Bolts

1. Clean area with non oil based cleaner, ie alcohol wipe.
2. Apply clear protective tape to left and right top corners of the tailgate as indicated.

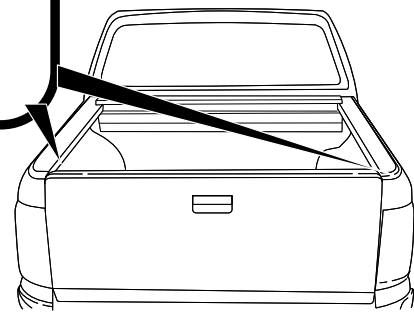
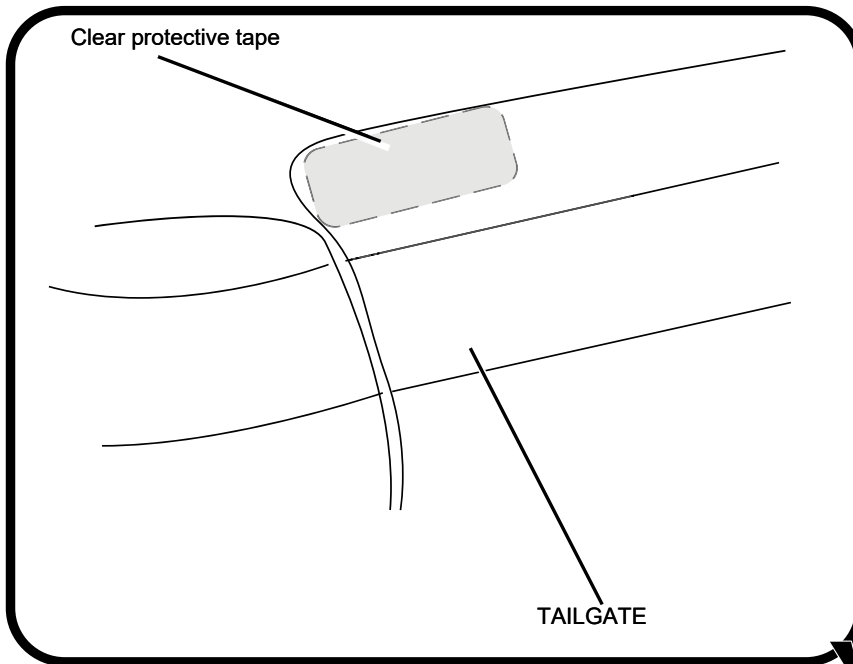
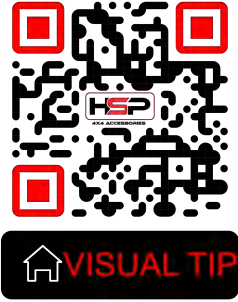

Install front drain pipes through pre-drilled holes of the canister. (RHS/LHS)



Note: With care push tube in. Gently pull the tube back so it seals correctly against the front panel of the tub.



VISUAL TIP

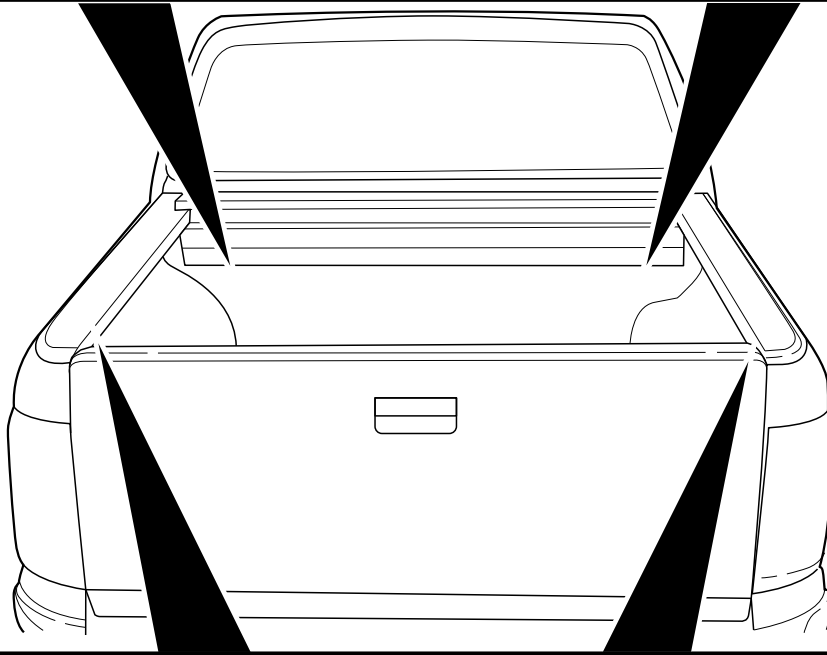
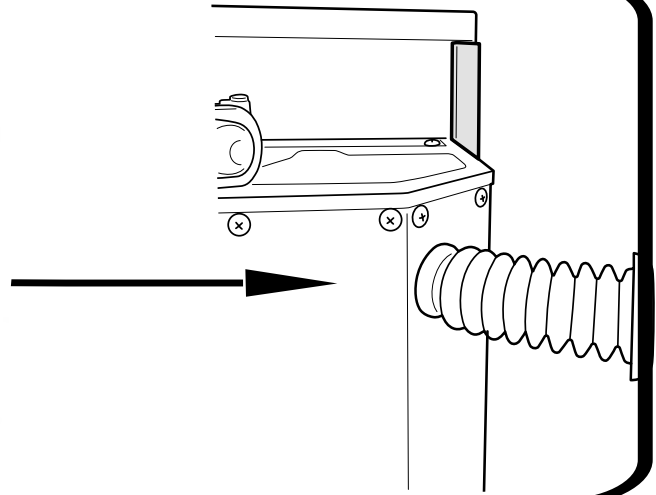
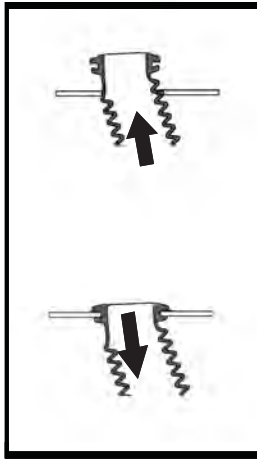

Note: With care push rear pipe in. Gently pull the pipe back so it seals correctly within the side rail channel.

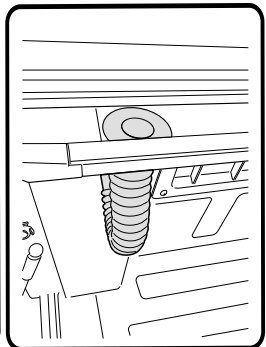
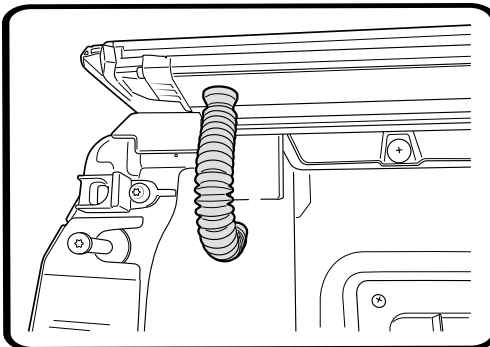
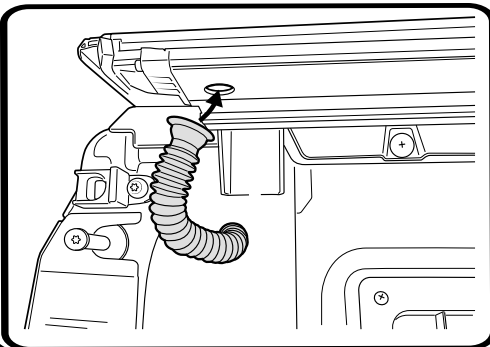
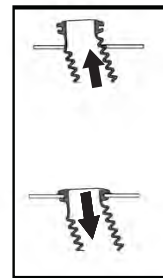

Install rear drain pipes through pre-drilled holes of the siderails. (RHS/LHS)

- a. Connect Battery loom S2.75 to Receiver loom.
- b. **Carefully** connect CI-Loom-short to Receiver loom.



Align connectors carefully to avoid pushing pins out.

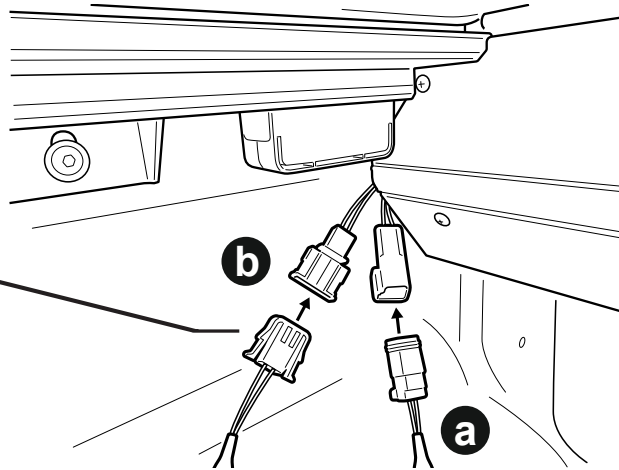

NOTE: 1. To wear in the Roll R Cover please fully open & close the cover approximately 15 times after install is complete.

2. Set your vehicle locking system to unlock all doors with one press of the factory remote unlock button. This setting can be found in your vehicle settings.

Operating instructions:

Press unlock on vehicle key fob to activate controller.

When vehicle is unlocked the side rail sensor buttons will be active to control.

When vehicle is locked the side rail sensor buttons will be inactive.

Using factory key fob to operate:

Pressing unlock twice on the factory key fob within 4 seconds, will activate the roll r cover to open.

Pressing lock twice on the factory key fob within 4 seconds, will activate the roll r cover to close.



Vehicle proximity:

Tapping the proximity twice to open or lock the car door will act exactly the same way as the key fob being pressed twice.

Touch & let go to open, touch & let go again to pause.

Touch & let go to close, touch & let go again to pause.

