



INSTALLATION INSTRUCTIONS

**To suit LDV T60
fitted with Armour bar**

This instructions has QR codes on relevant sections. You must scan the QR codes via your smart phone camera and watch the video to ensure your fitment is to standard.



INSTALLATION TIME: 1 hours and 45 minutes (Approximately)

IMPORTANT	<ul style="list-style-type: none"> • Do not stand/sit or rest heavy objects on Roll R Cover • Humans or animals are not to be under the closed cover at any given time • Tonneau Cover is not dust or water tight • If contact with volatile chemicals occur, clean Cover with mild detergent and water solution 			
Care Instructions	<ul style="list-style-type: none"> • Read Instructions fully before commencing installation. • Clean Cover with a mild detergent and water solution • Do not use abrasive cleaners or solvents • Refer to manufactures instructions applicable to power drill. • Protect Tub floor against scratches during installation process. 			
Maintenance	Refer to Maintenance instructions.			
Tools Required	<table style="width: 100%; border: none;"> <tr> <td style="vertical-align: top;"> <ul style="list-style-type: none"> • Pen / Marker • Centre Punch • Drill & Drill bits • Caulking Gun • Silicon - Non Acetic </td> <td style="vertical-align: top;"> <ul style="list-style-type: none"> • Scissors & Knife • Spanner & Socket • Tape measure • Holesaw • Filing tool </td> <td style="vertical-align: top;"> <ul style="list-style-type: none"> • Soapy water solution • Allen Key set • Screw driver • Rust Inhibitor • Trim Removal Tool </td> </tr> </table>	<ul style="list-style-type: none"> • Pen / Marker • Centre Punch • Drill & Drill bits • Caulking Gun • Silicon - Non Acetic 	<ul style="list-style-type: none"> • Scissors & Knife • Spanner & Socket • Tape measure • Holesaw • Filing tool 	<ul style="list-style-type: none"> • Soapy water solution • Allen Key set • Screw driver • Rust Inhibitor • Trim Removal Tool
<ul style="list-style-type: none"> • Pen / Marker • Centre Punch • Drill & Drill bits • Caulking Gun • Silicon - Non Acetic 	<ul style="list-style-type: none"> • Scissors & Knife • Spanner & Socket • Tape measure • Holesaw • Filing tool 	<ul style="list-style-type: none"> • Soapy water solution • Allen Key set • Screw driver • Rust Inhibitor • Trim Removal Tool 		

PERSONAL PROTECTIVE EQUIPMENT:



Rubber Gloves



Goggles



Hearing Protection

BOX CONTENTS

LEFT & RIGHT SIDE RAIL

S2.5-DC-AE-002ps-LD4 

S2.5-DC-AE-003ds-LD4 



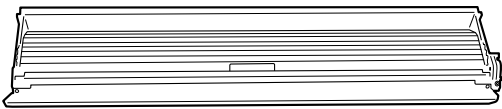









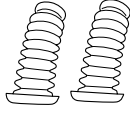

CANISTER ASSEMBLY

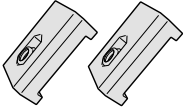
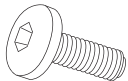

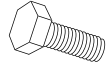

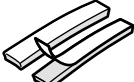

S3-DC-AF-GW4R_LD4R-001/002

CANISTER TOP COVER  S2.5-DC-AE-005 -LD4

SPECIFIC KIT LD4R

<p>COVER END CAPS</p>  <p>S2.5-DC-PI-004ps</p>  <p>S2.5-DC-PI-004ds</p>	 <p>COUNTERSUNK SCREW Qty - 4</p>	 <p>CABLE TIE Qty x 16</p>	 <p>BATTERY LOOM S2.75</p>	 <p>Drainage pipe Qty - 2</p>	 <p>Rear Drainage pipe Qty - 2</p>
 <p>SIDERAIL CLAMP Qty - 4</p>	 <p>M8 x 35mm Qty - 4</p>	 <p>M8 WASHER Qty - 6</p>	 <p>M8 SPRING WASHER Qty - 6</p>	 <p>M8 x 25mm Hex head bolt Qty - 2</p>	 <p>M8 NUT Qty - 4</p>
 <p>50449 D-SPONGE Qty-2</p>	 <p>CL-LOOM-LONG</p>	 <p>LD-PATCH-K</p>	 <p>Clear protective tape (30mm x 65mm) Qty - 2</p>		

SPECIFIC KIT AB1

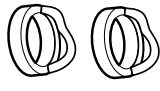
 <p>M8 FLAT WASHER Qty - 4</p>	 <p>M8 SPRING WASHER Qty - 4</p>	 <p>M8 x 40 ALLEN Head Bolt Qty - 4</p>	 <p>3M PRIMER</p>	 <p>SIDERAIL HOLE GASKET Qty - 5</p>	
--	--	---	---	--	--

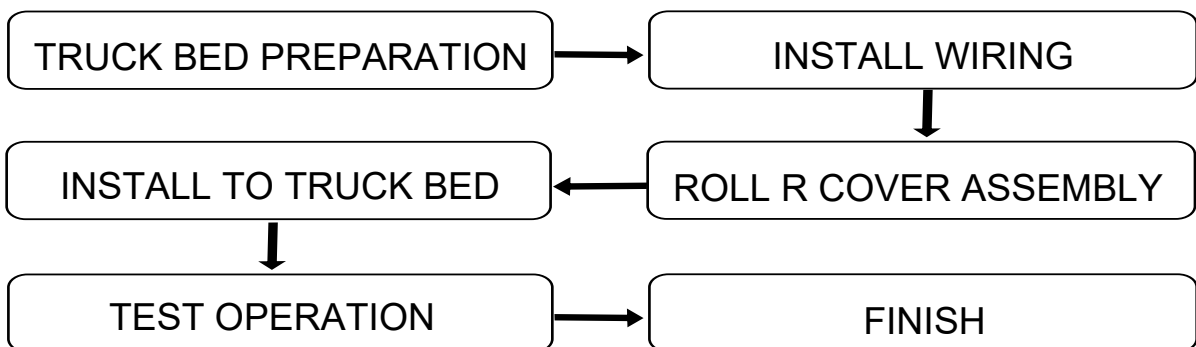

TUB PREPARATION

If the Vehicle is fitted with a cabin guard or sports styling bar, remove from Ute Tub (truck bed).

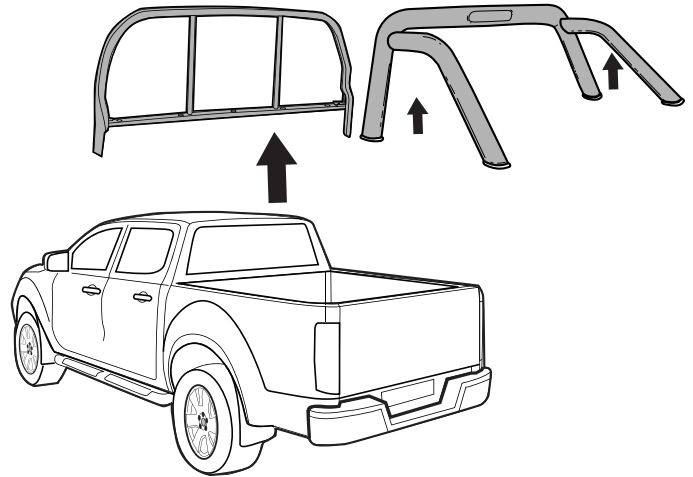

Clean areas as indicated.

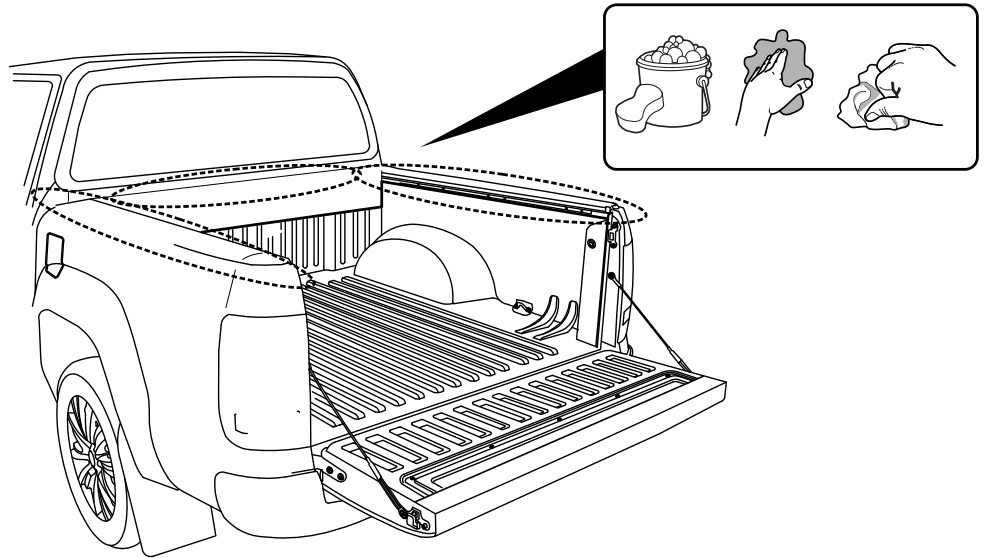

Remove and discard the indicated M8 torx bolts located to the rear of the tub.
Repeat to the other side.

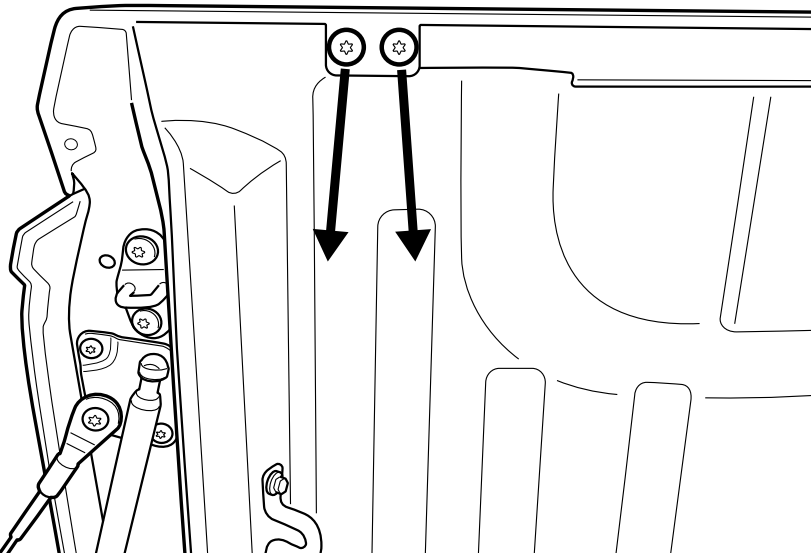
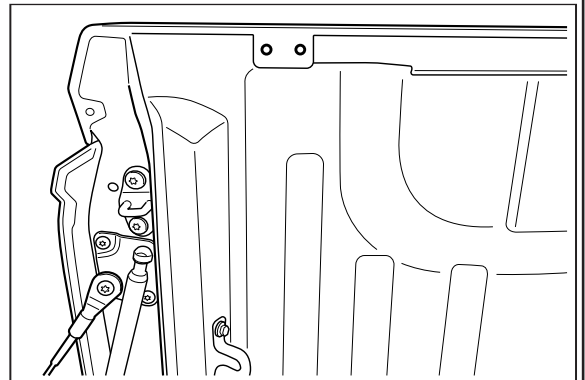

Measure down from top of headboard 215mm & 70mm from inside wall of bed liner as shown. Repeat to the other side.
Using a 50mm hole-saw drill the liner only as indicated.

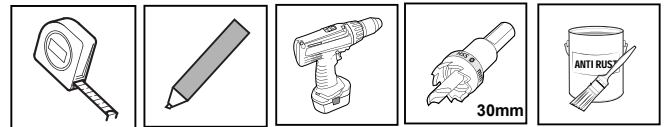
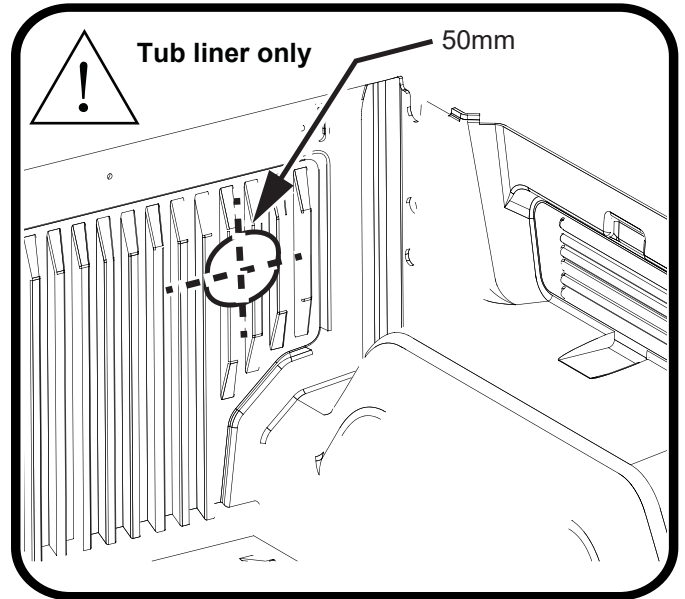
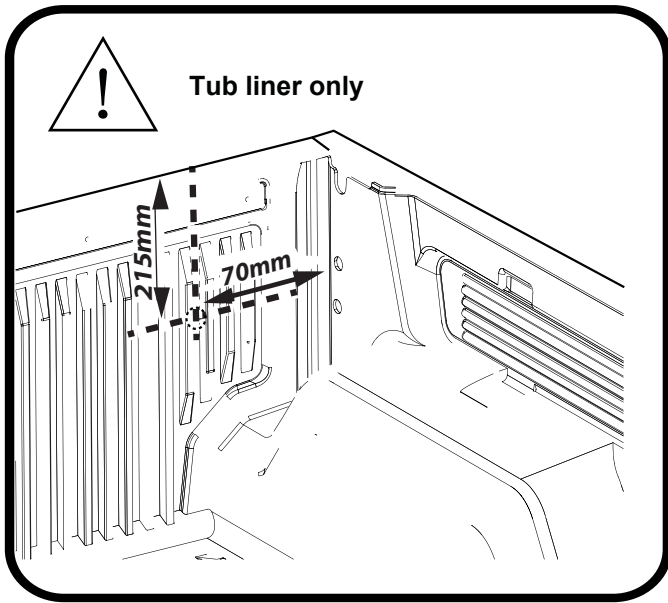
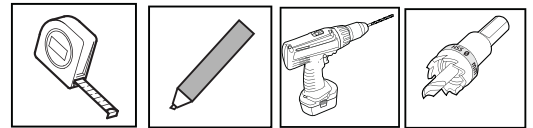

Measure down from top of headboard 215mm & 70mm from inside wall of bed as shown. Repeat to the other side.
Using a 30mm hole-saw drill through tub front panel, file away any sharp edges. Apply anti rust coating. Repeat to other side.

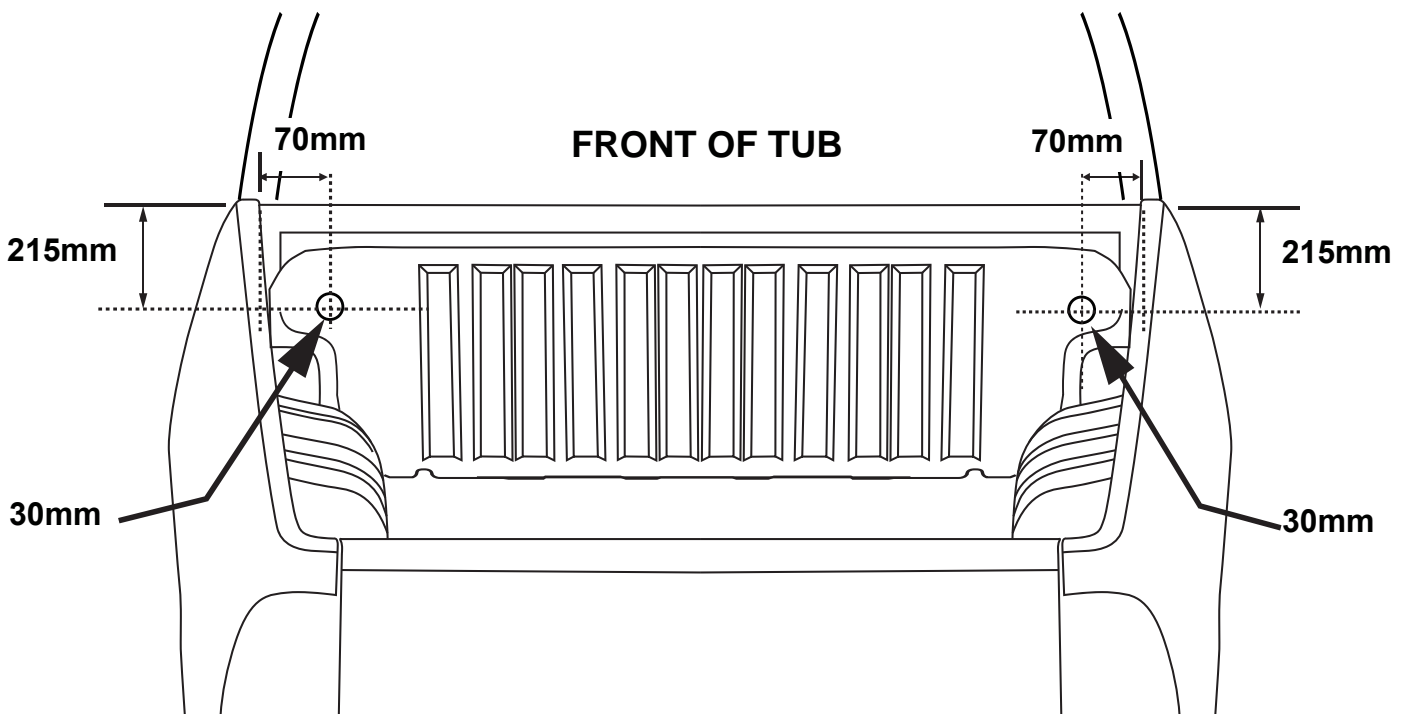

! ATTENTION: Do not exceed 30mm hole.

Seal any exposed gaps or holes on the front panel of the Ute bed with sealant.

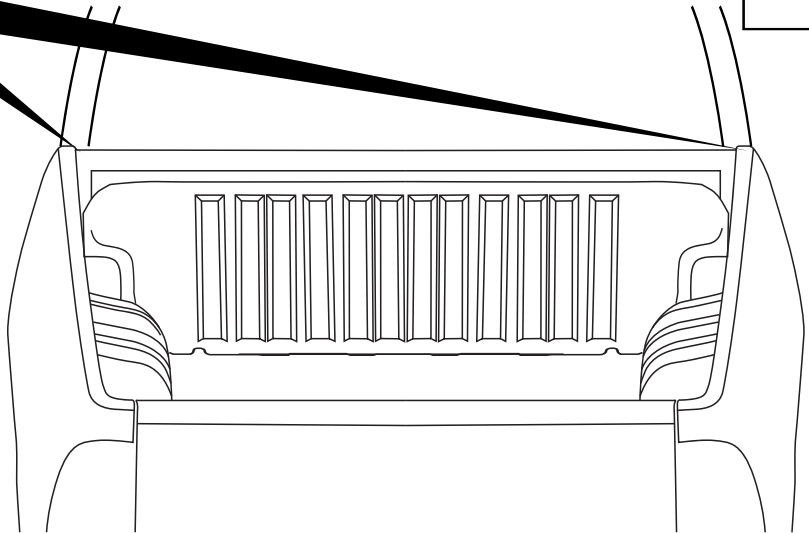
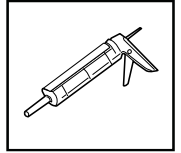
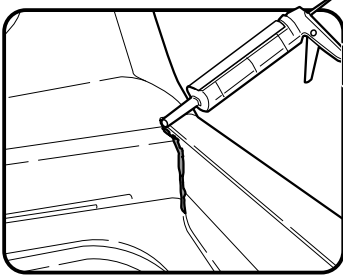

Carefully unpack the box.

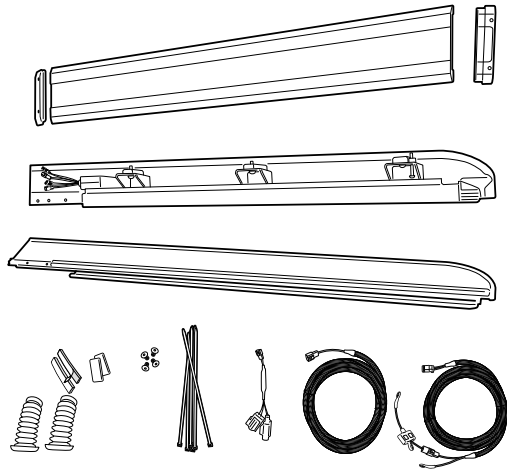
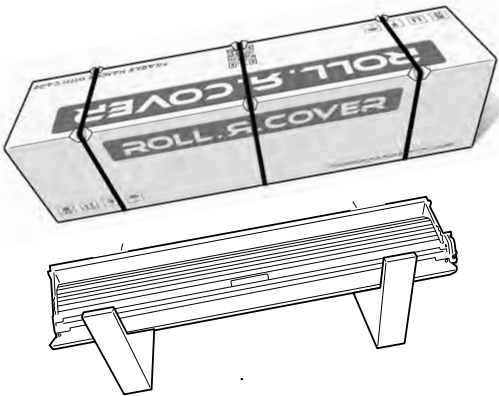

Install front drain pipes (55mm diameter end of hose) through pre-drilled holes on the front tub panel.



Note: With care push tube in.
Taking care pull the tube back so it seals correctly against the front panel of the tub.

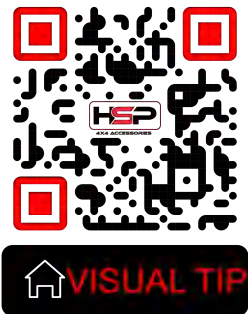
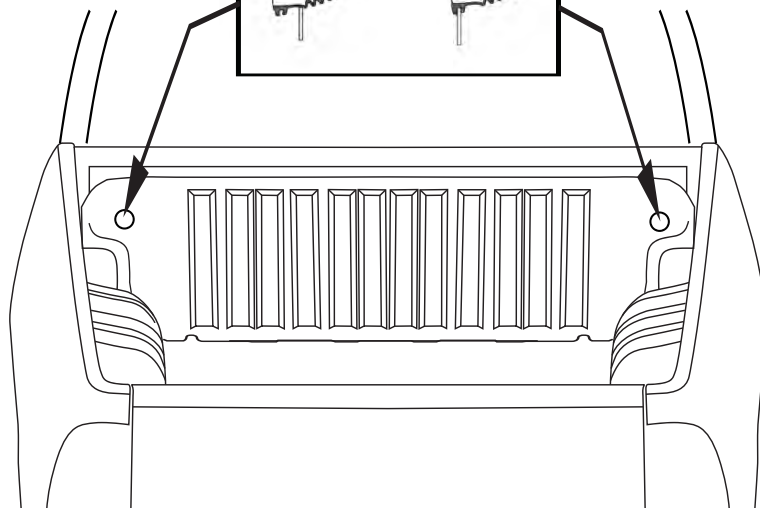
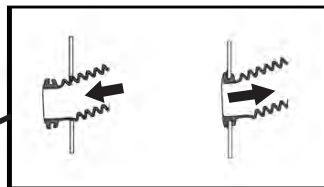

Remove and retain tail lights.

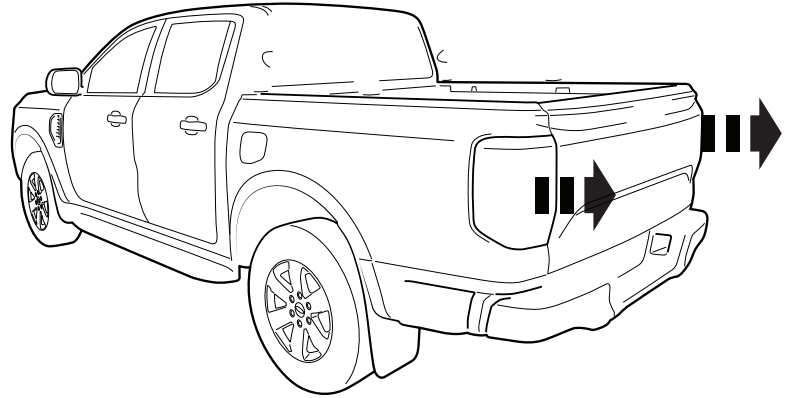

Measure 75mm towards the tailgate from the center of the indicated factory M8 bolt. Measure down 85mm from the top edge of the tub as directed and make a mark. Use a 15mm hole-saw to drill through the tub pillar, and file away any sharp edges. Apply an anti-rust coating. Repeat the same steps on the other side.

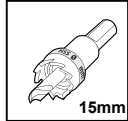
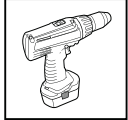
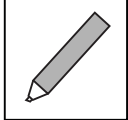
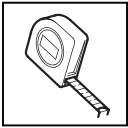

! ATTENTION: Do not exceed 15mm hole.

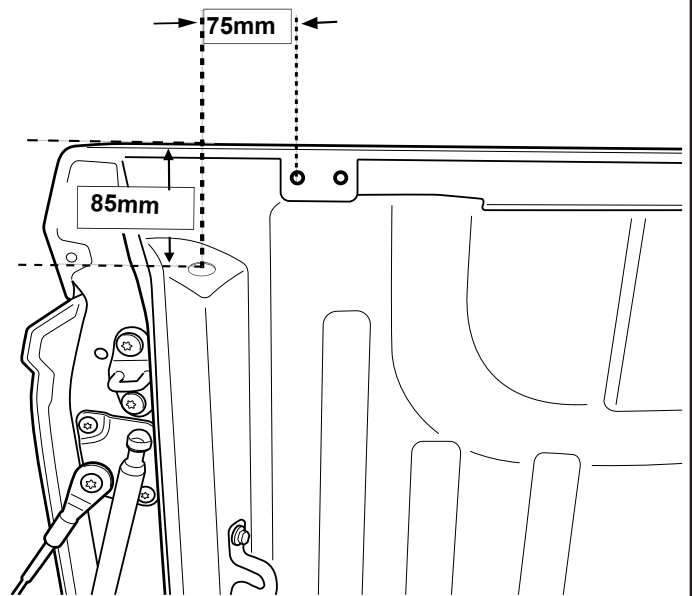

- a** In the specified orientation insert the rear drainage pipe into the previously drilled hole.
 - b** Leaving 150mm of the pipe hanging out.
 - c** Check the tail light cavity to ensure there are no obstructions to the drainage pipe. Repeat to the other side.
- Re-fit the tail lights.

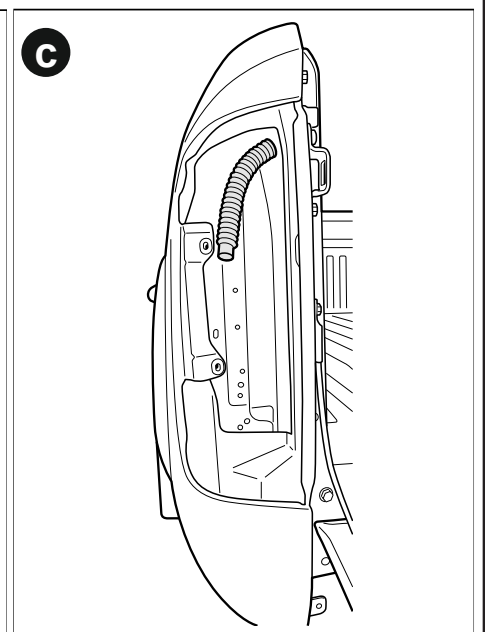
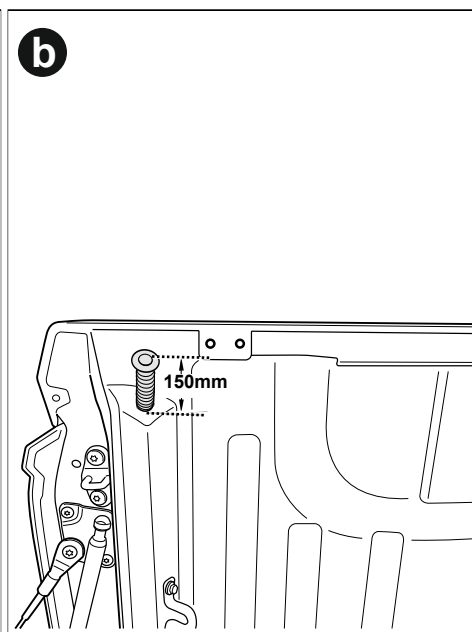
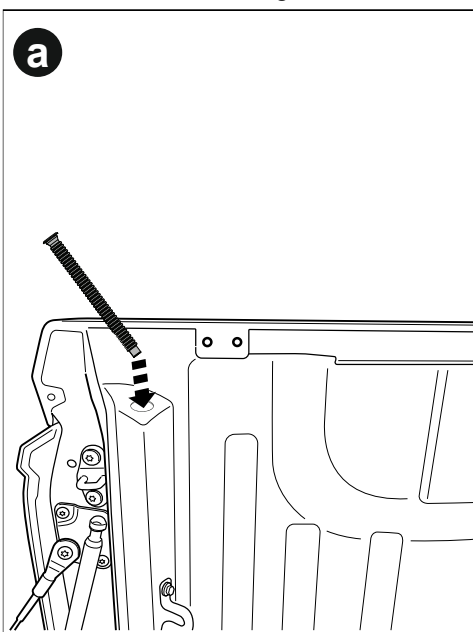

Disconnect fuse patch from battery loom S2.75.

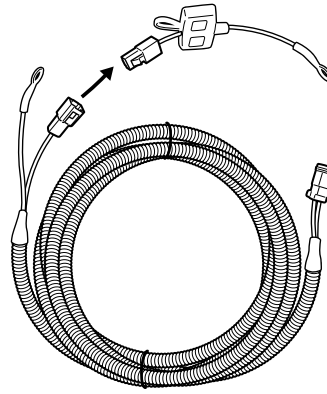

Wiring Harness steps

1 Feed Battery Loom S2.75 through the cavity

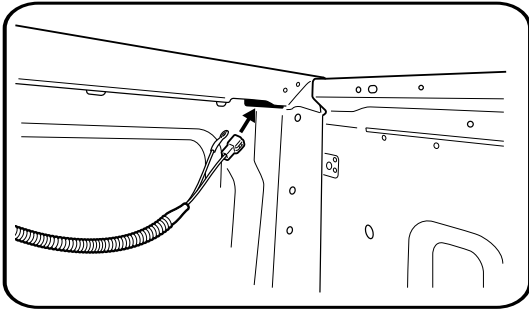

3

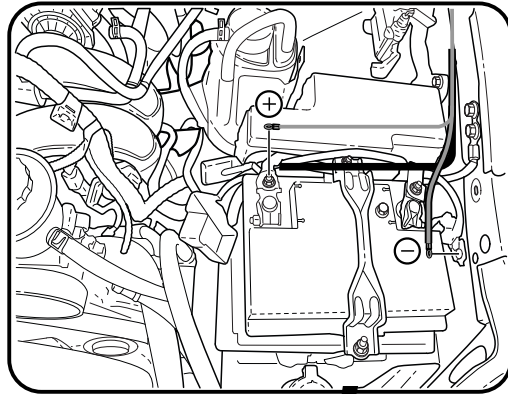

2

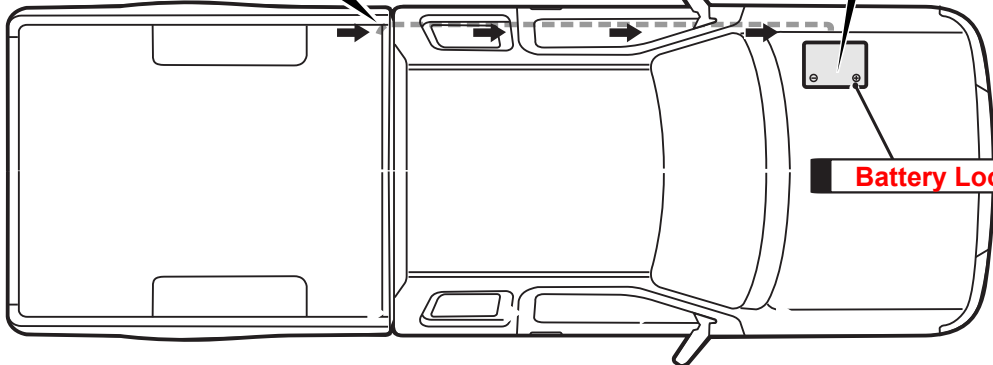

Run the wiring from the front corner cavity (leaving 200mm in the tub) to the battery over the chassis rail. Making sure to keep away from hot obstructions and cable tie every 400mm. Reconnect fuse patch to battery loom S2.75, now attach fuse patch to positive of battery and earth to the body of the Ute.

Feed CL-Long-Loom through drivers side cavity leaving 200mm in the tub.

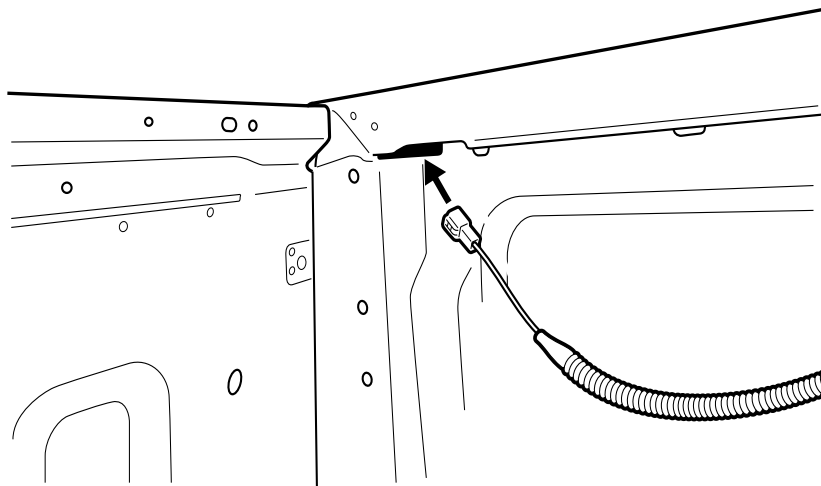

Run wiring from passenger side of the tub to drivers side of tub then feed through cavity on tub. Now run to drivers side kick panel. Cable tie wiring every 500mm over chassis rail. Find the large grommet on the firewall, make a small incision & run the loom through it to enter the cab and towards the kick panel. Seal accordingly.

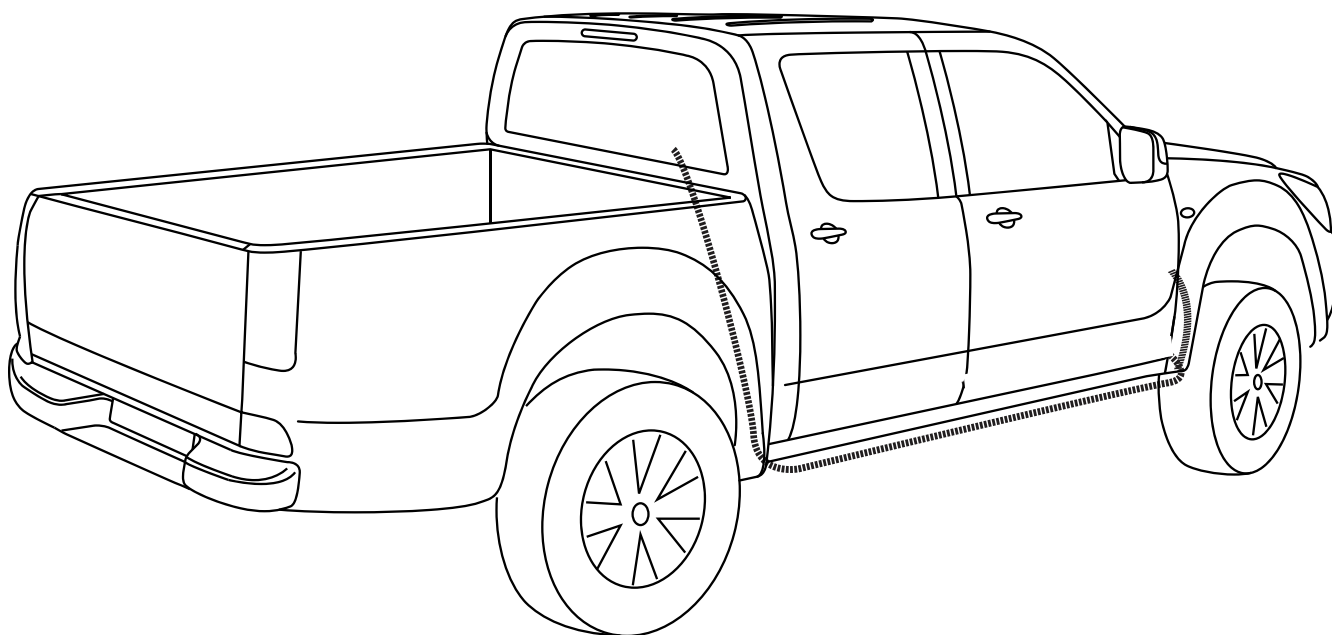

Carefully remove the drivers side scuff and kick panel.

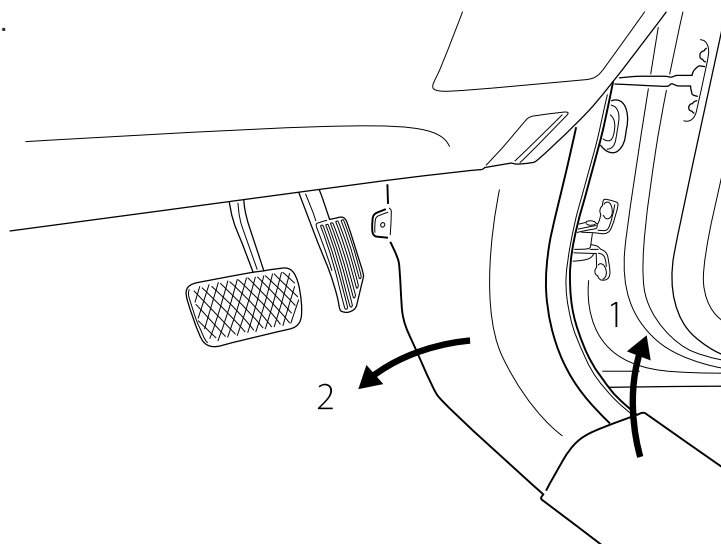

look up above the kick panel area

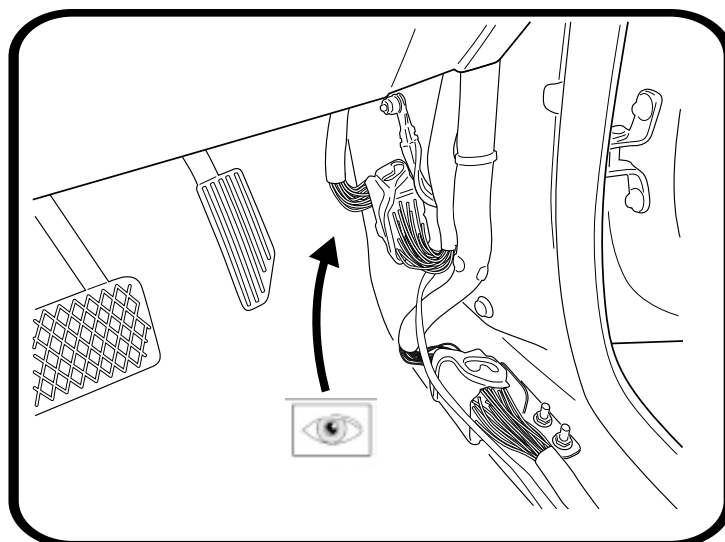

locate connector as indicated and unplug.

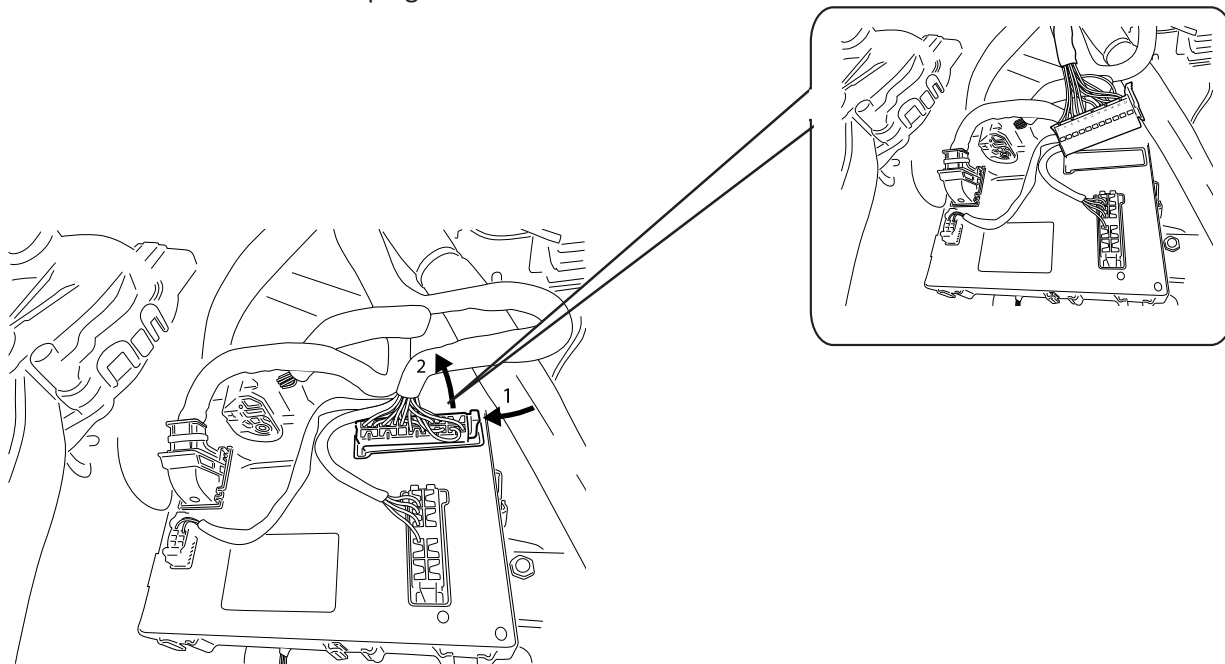

Un-clip the plugs interface to gain access to the wire's.

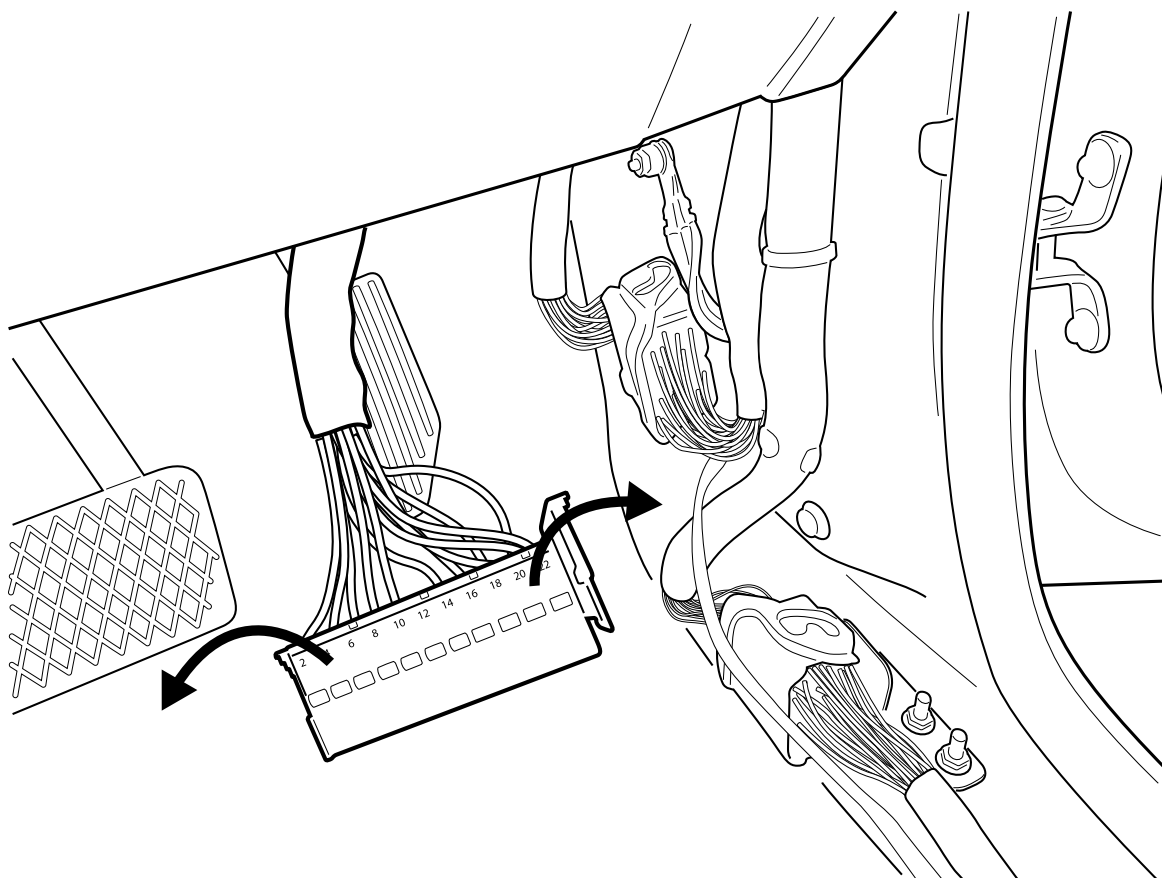

Remove the brown wire (18) and grey wire (20) from the plug.

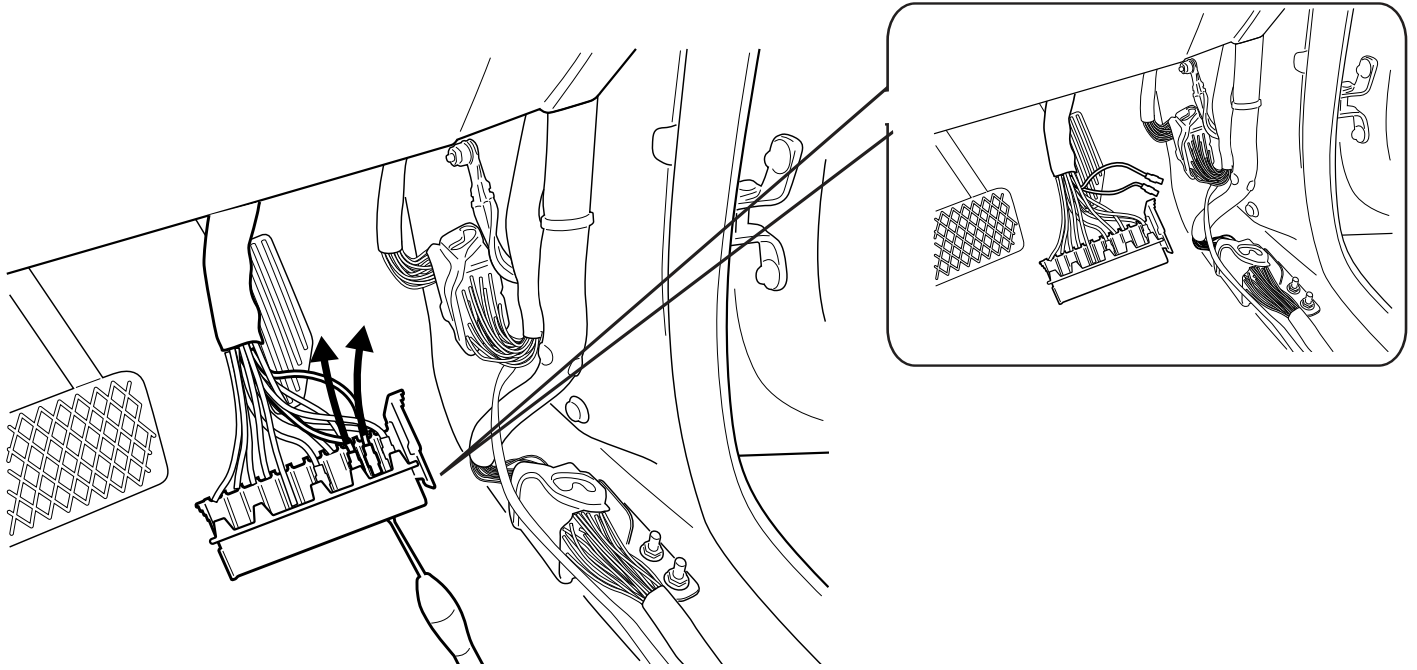

Using male connector (LD patch).

- A = Grey wire
- B = Brown wire

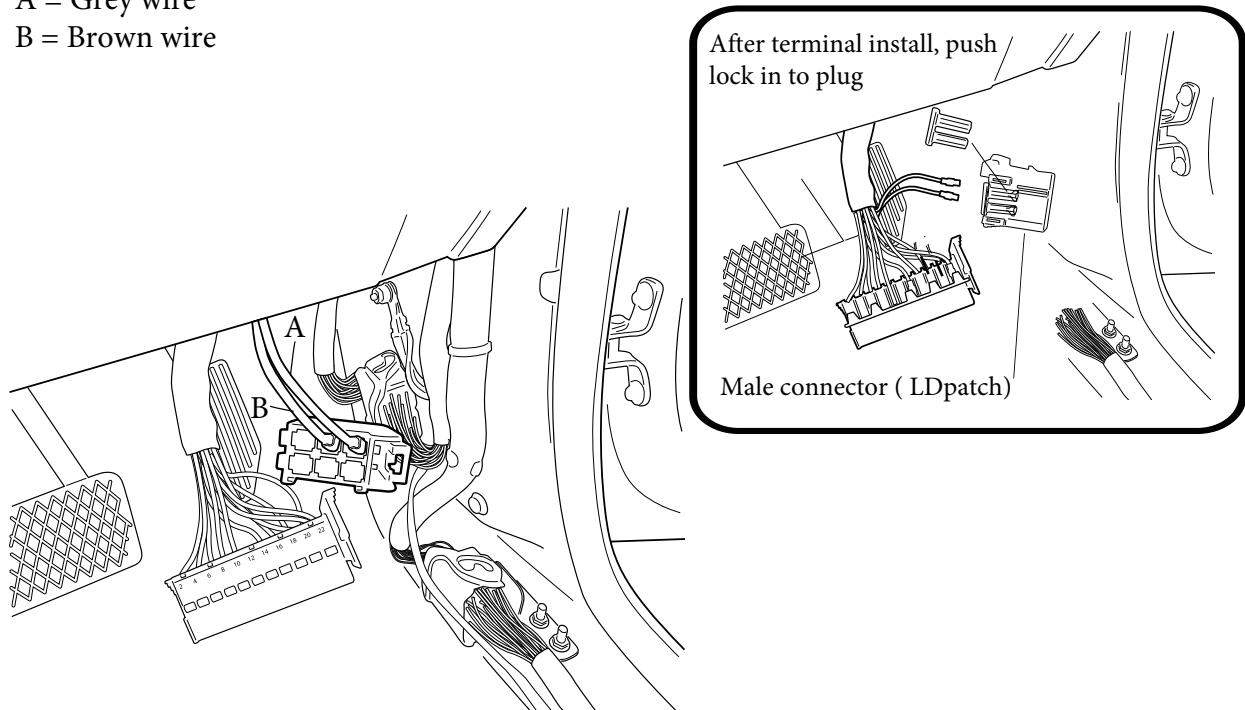

Using the LD- patch provided in the kit, plug the green wire to (20) & blue (18) on the factory plug.

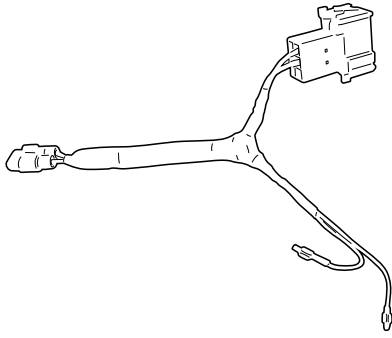

Making sure the wires are connected according to factory orientation

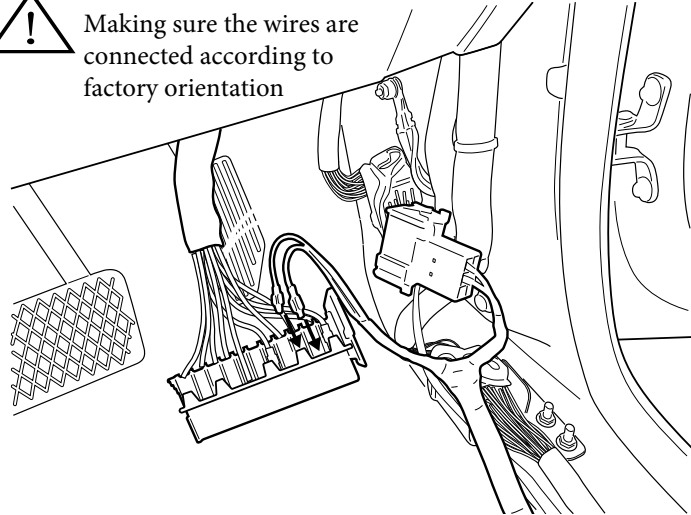

Clip the connector lock back so the wires are secured.

Plug the male connector to the female connector of the LD patch.

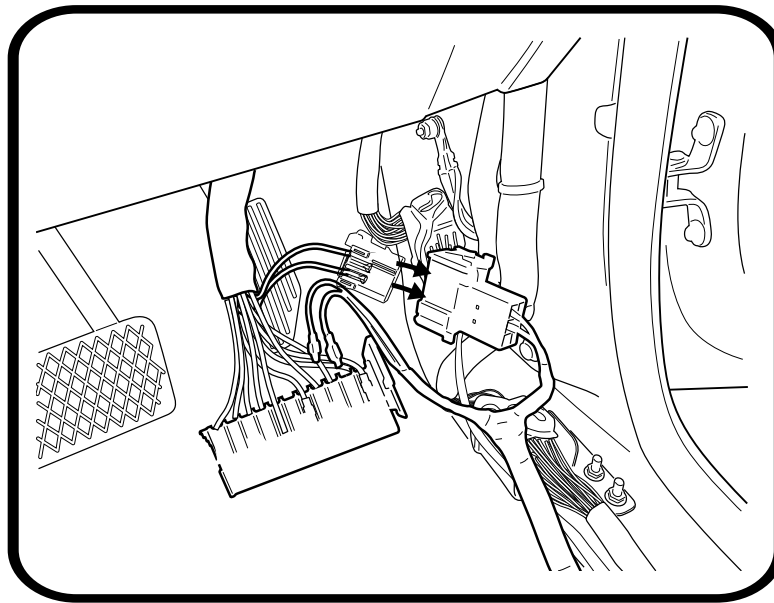

Connect the male and female plugs from LD-patch & CL-Long- Loom.

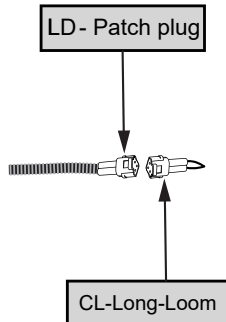

keep the cannister in the foam blocks from the packaging for assembly.

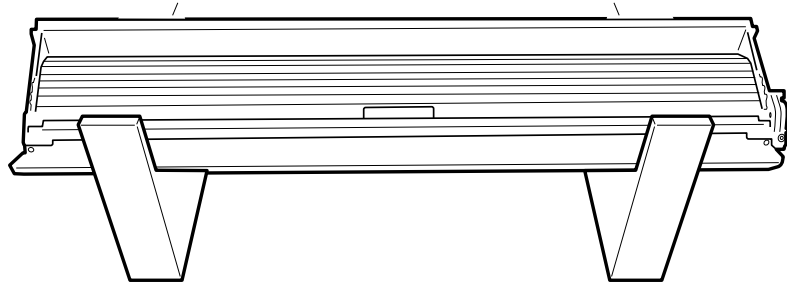

With assistance turn the canister on its back on the foam blocks.

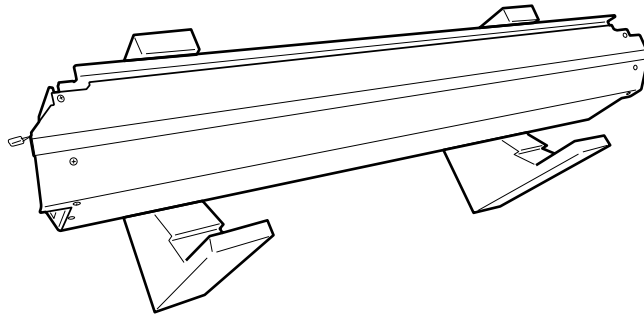

Disengage motor from the axle by unfastening the 3 Screws as indicated. Retain all parts.

Remove and retain the 3 screw from the canister as indicated.

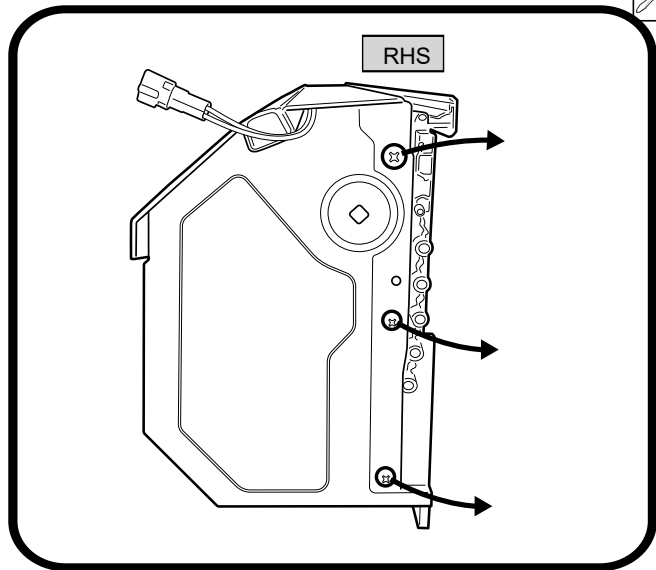
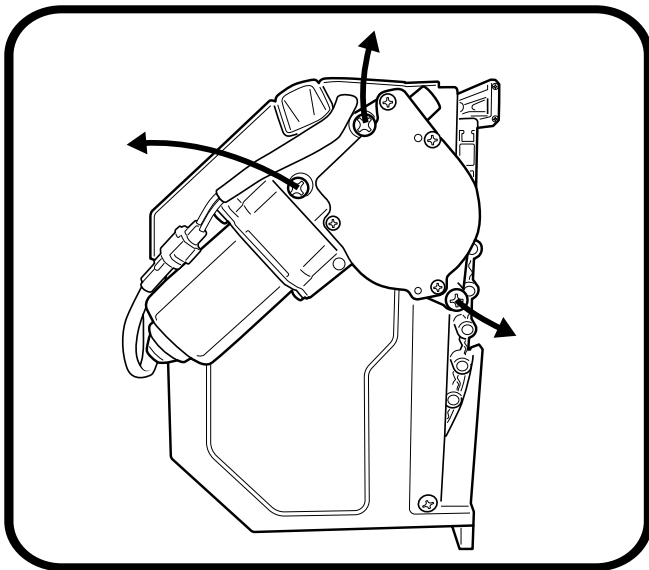

Now on the other side, remove and retain the 4 screws from the canister as indicated.

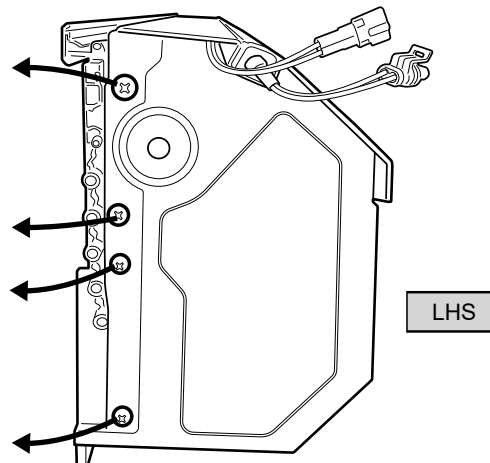
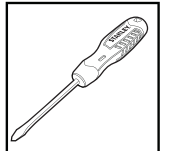



Important Note: Ensure that the Z seal within the track is positioned over the curtain and not folded inward. **WARRANTY** voided if assembled incorrectly.

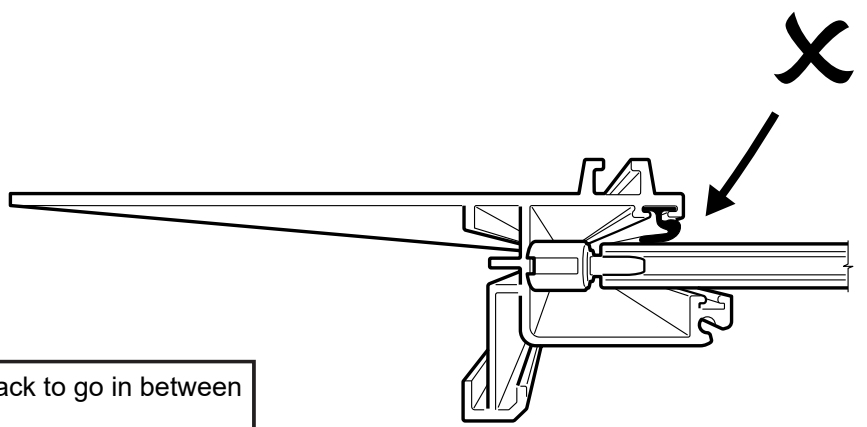
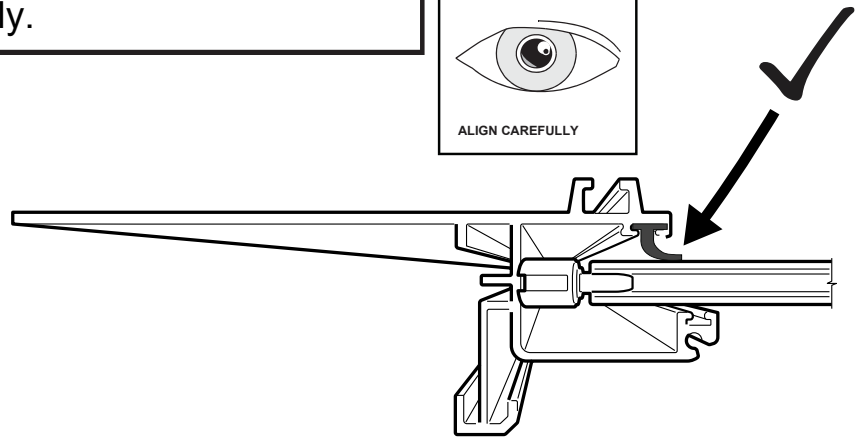
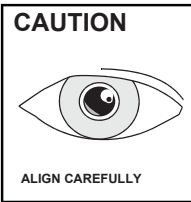

 **VISUAL TIP**

Align side rail to side of canister, guide the track to go in between the curtain end rubber stop.
NOTE: LHS side rail to be assembled first.

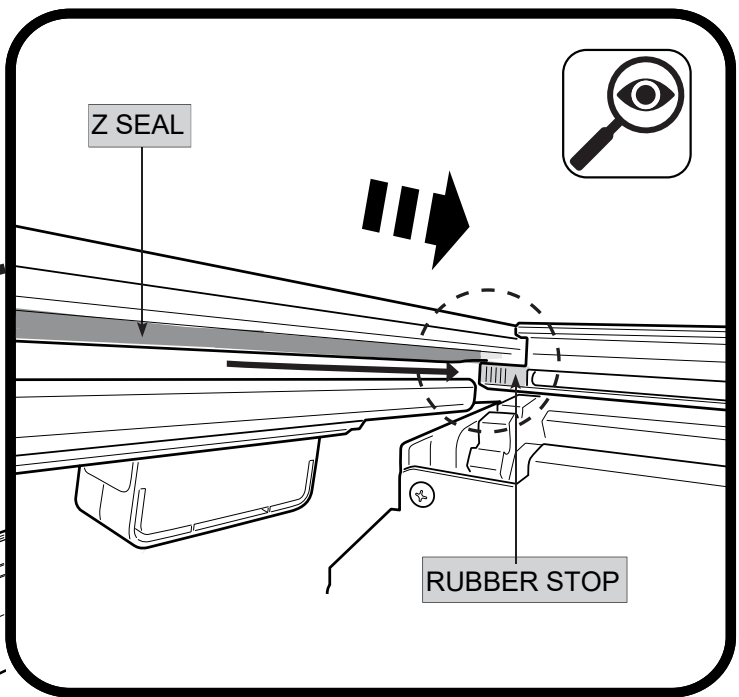
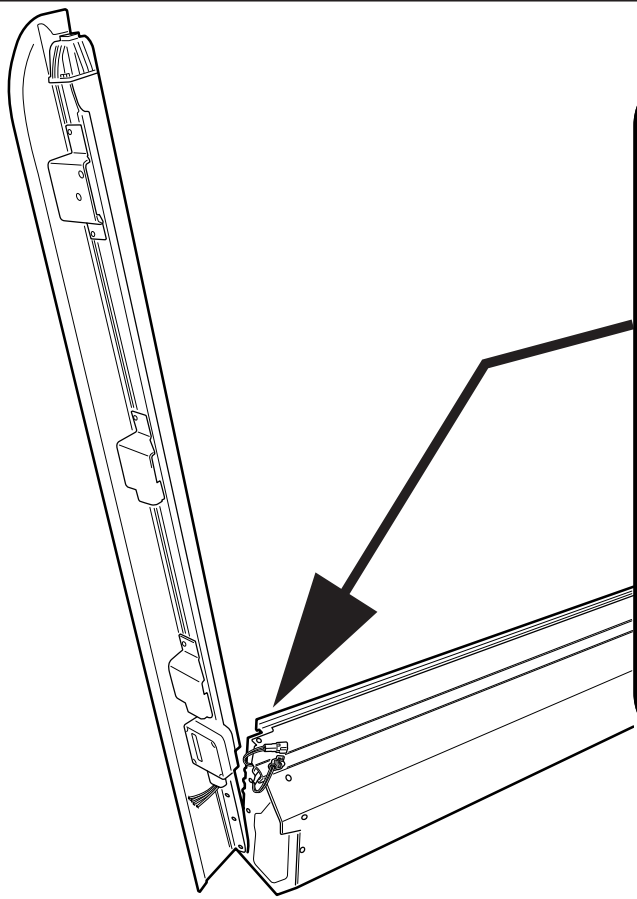

1. Using the retained screws, spring washer and washer, Loosely fasten the side rail to the location indicated.
2. Side rail edge must compress and meet with the canister profile as indicated below.
3. Fasten all screws tight.

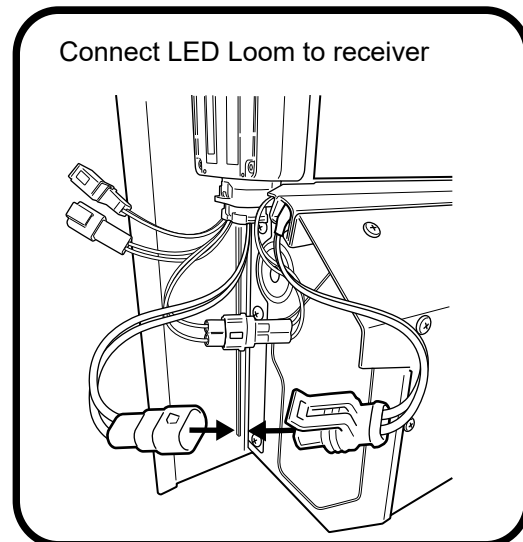
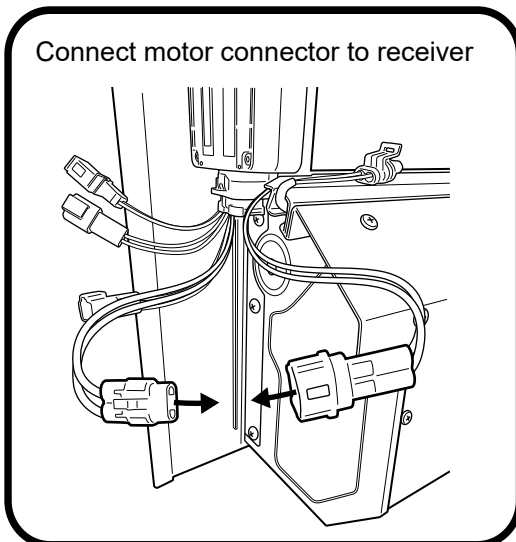
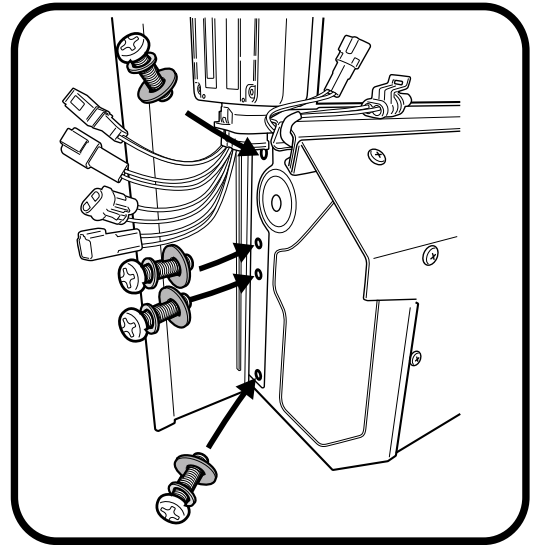
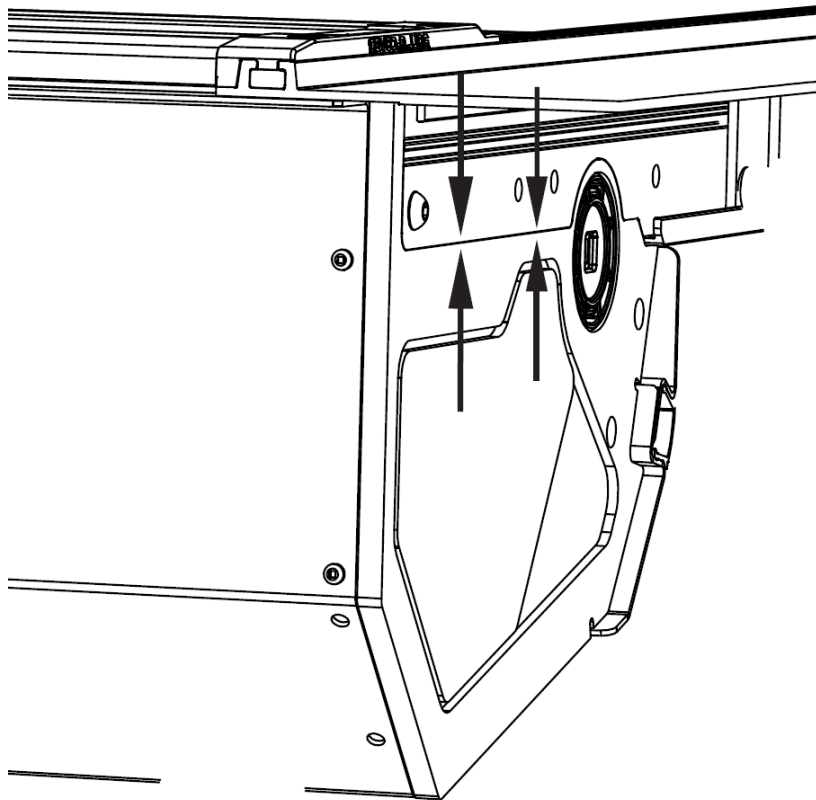
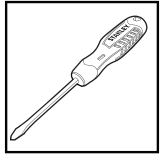



Important Note: Ensure that the Z seal within the track is positioned over the curtain and not folded inward. **WARRANTY** voided if assembled incorrectly.

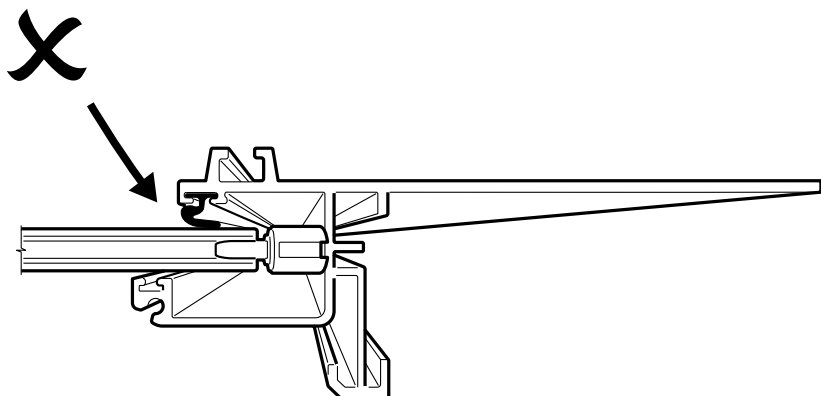
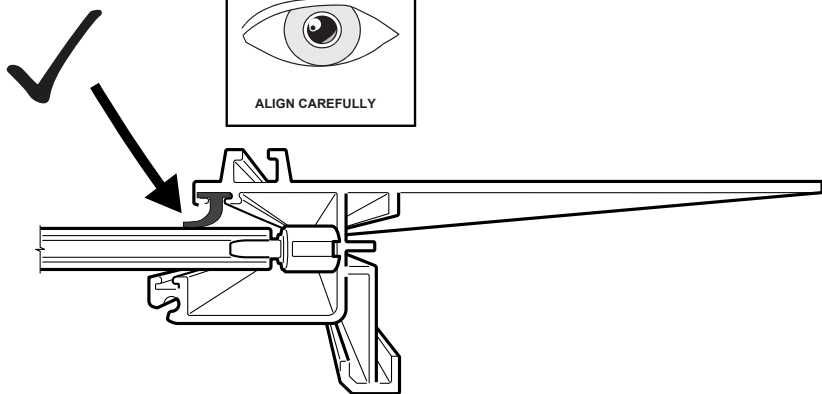
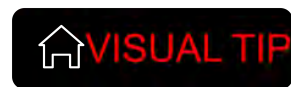

Align side rail to side of canister, guide the track to go in between the curtain end rubber stop.

NOTE: LHS side rail to be assembled first.

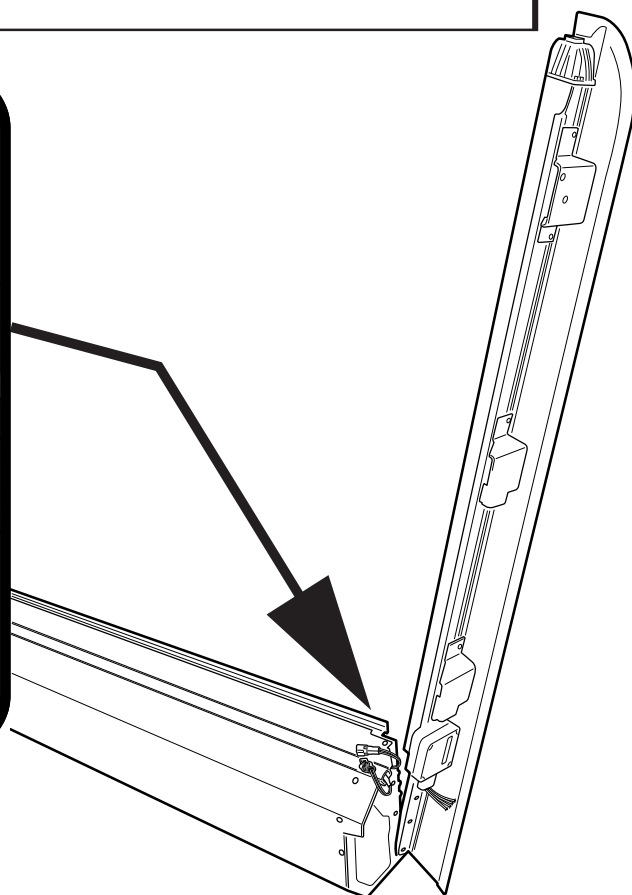
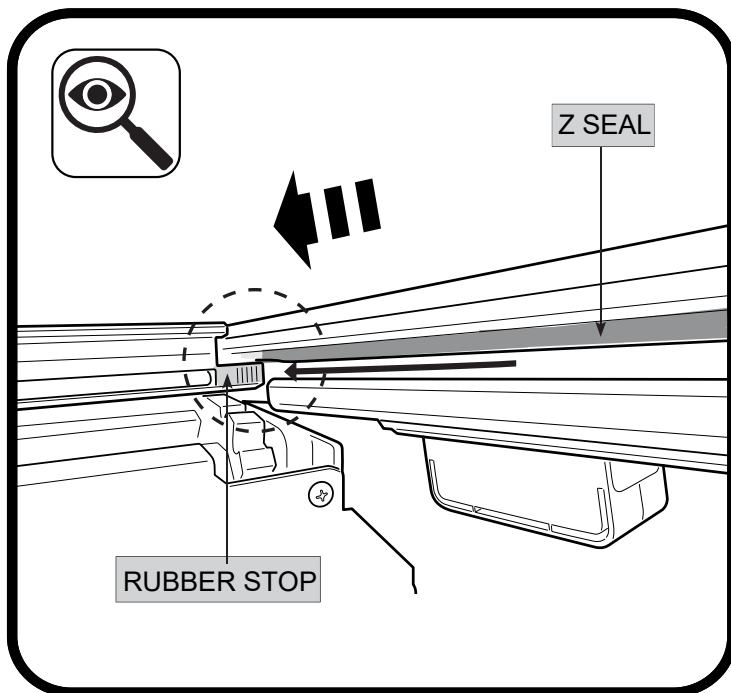

1. Using the retained screws, spring washer and washer, Loosely fasten the side rail to the location indicated.
2. Side rail edge must compress and meet with the canister profile as indicated below.
3. Fasten all screws tight.

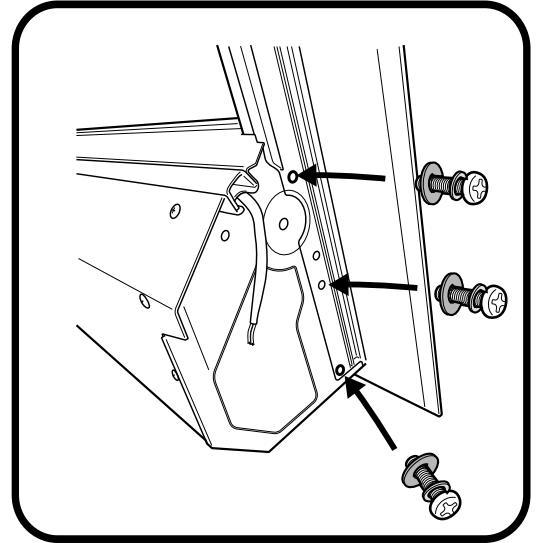
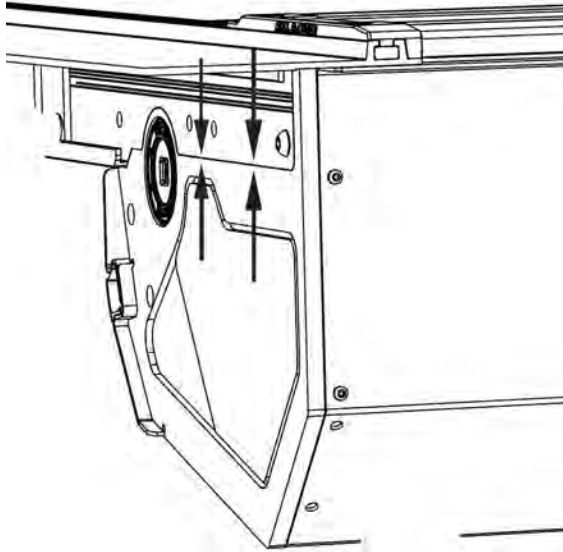
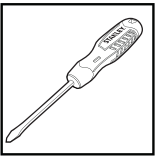

Feed M6 bolt through spring washer, motor and rubber bush.

NOTE: Rubber bush orientation has to be as per image. (side with text on rubber, to face the motor).

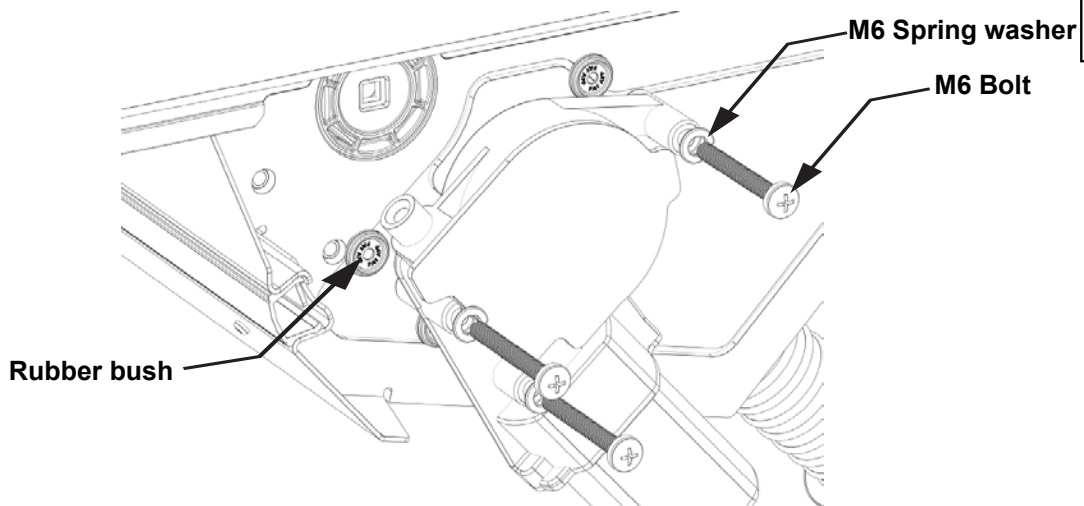
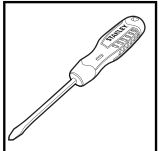

Align & insert motor shaft to axle.

NOTE: Pull / push curtain for axle to rotate.

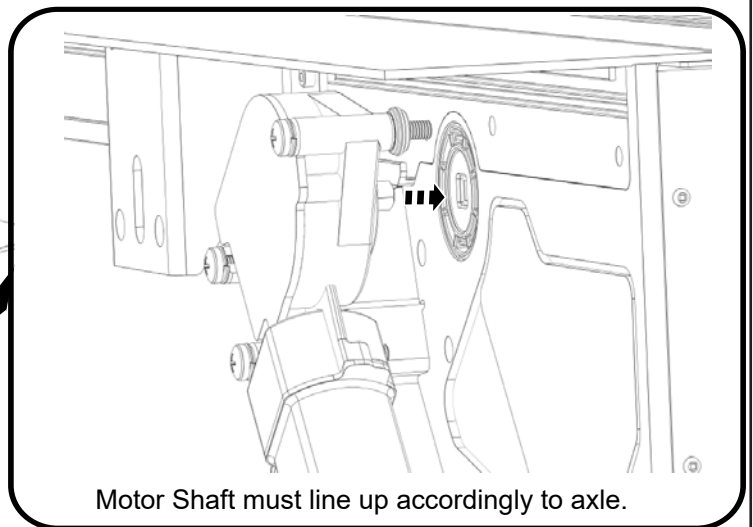
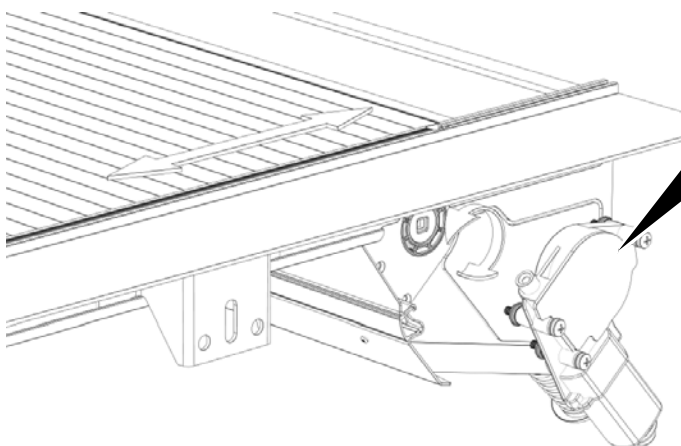

Motor Shaft must line up accordingly to axle.

Fasten all 3 screws to 2nm torque. Over tensioning will cause operating issue's.

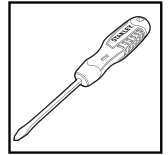
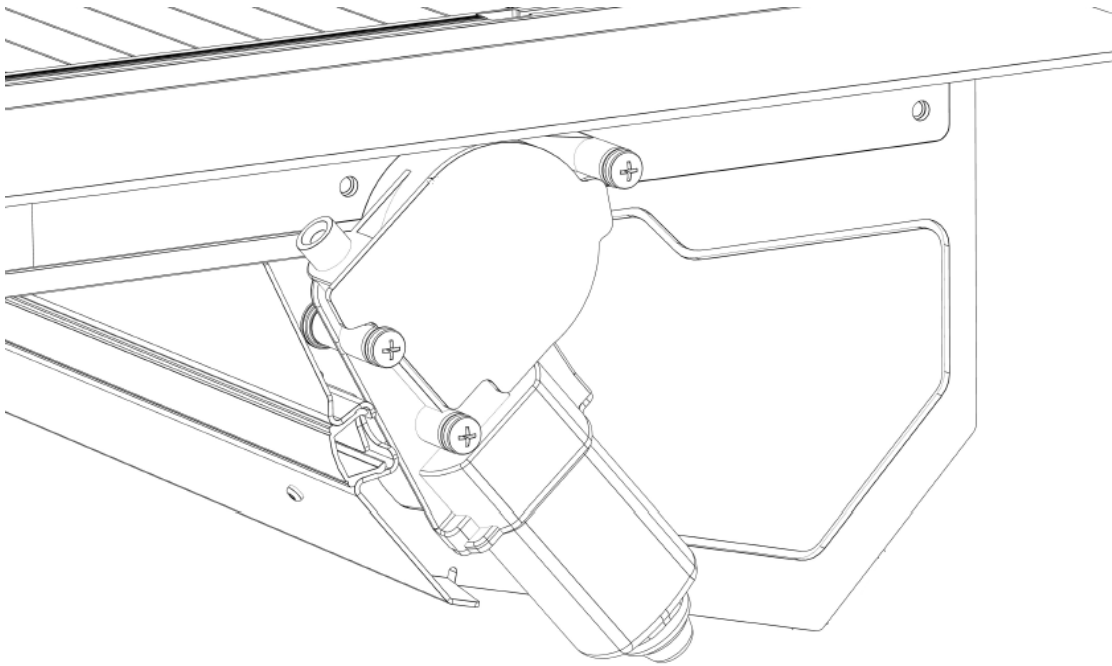

Motor is to sit level.

Any obstructions between motor and canister may cause operating issues.

Apply D-sponge foam tape to side rail as indicated. NOTE: Join foam firmly to the per-fitted foam of the canister. Carefully trim excess off & discard as indicated. Repeat on the other side.

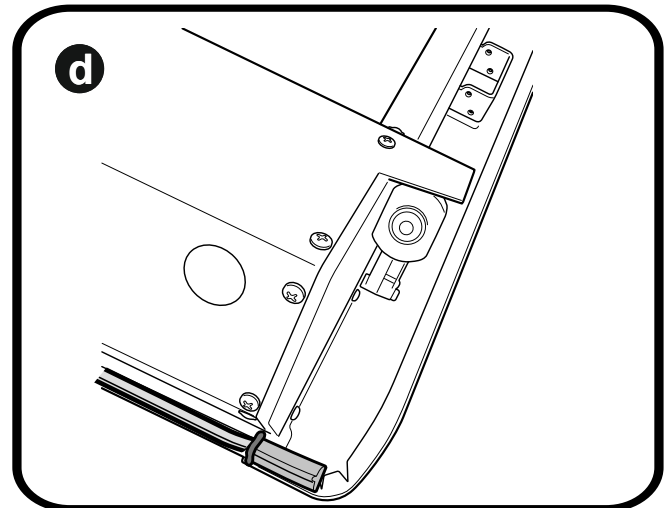
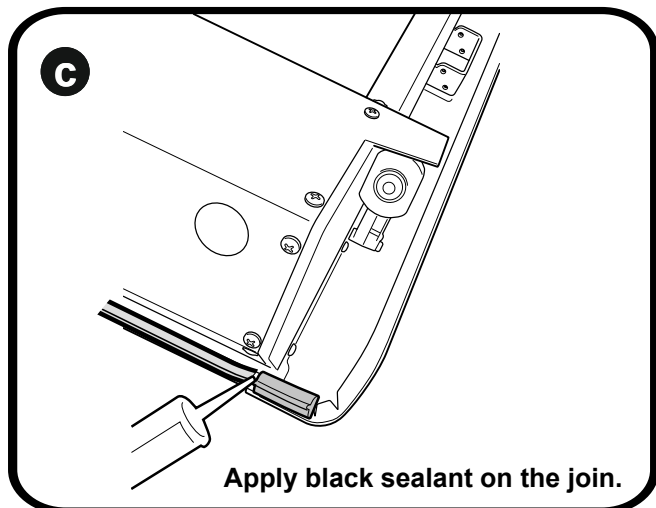
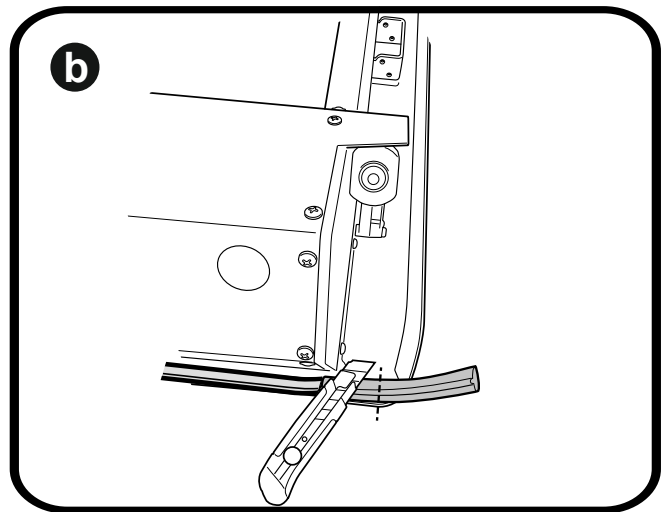
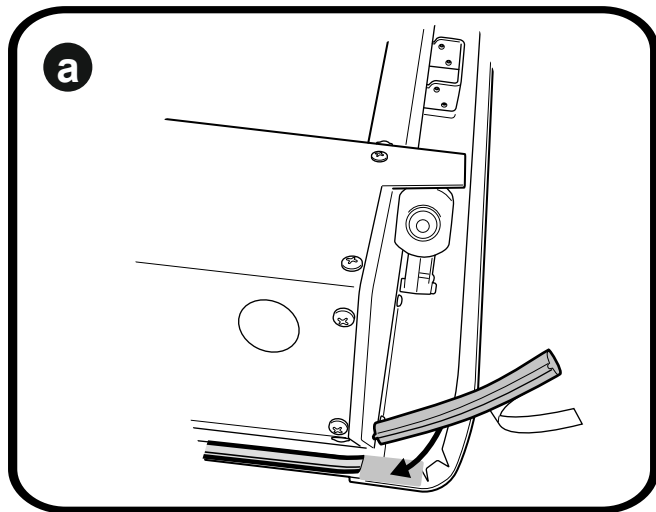

Carefully bring down the assembled unit.
If side seal on the side rails has moved, carefully bring back into position.

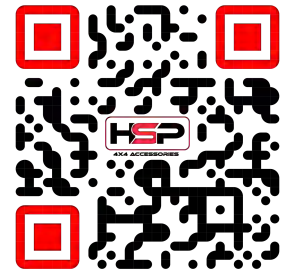
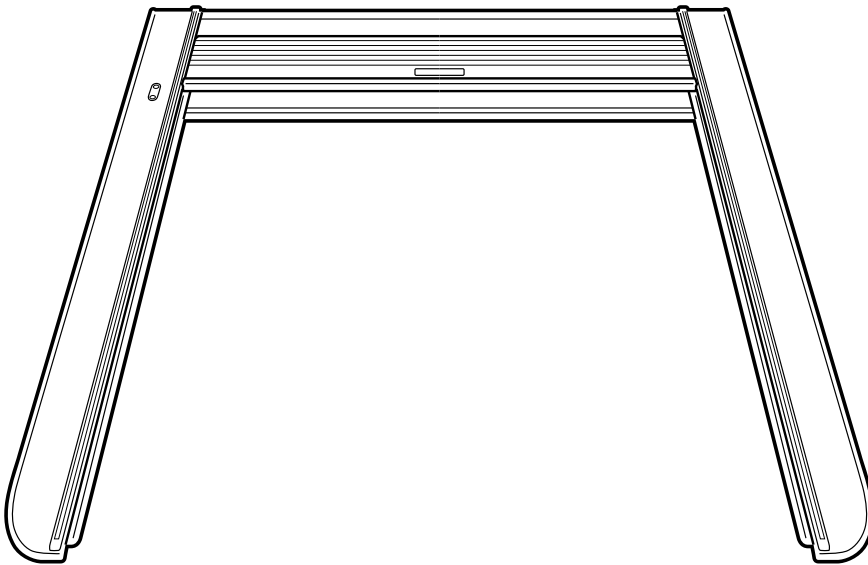

Insert side end caps to the top cover.

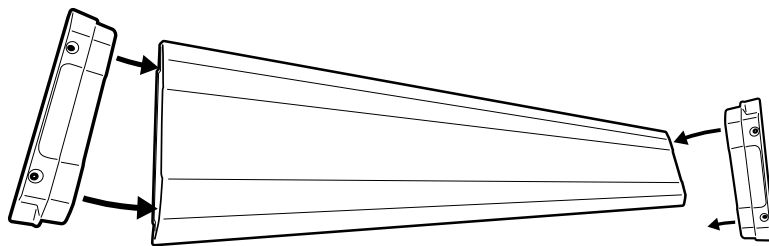
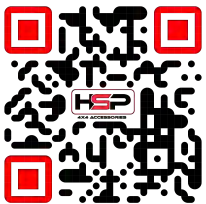

Place & Align top cover over the canister and side rails.

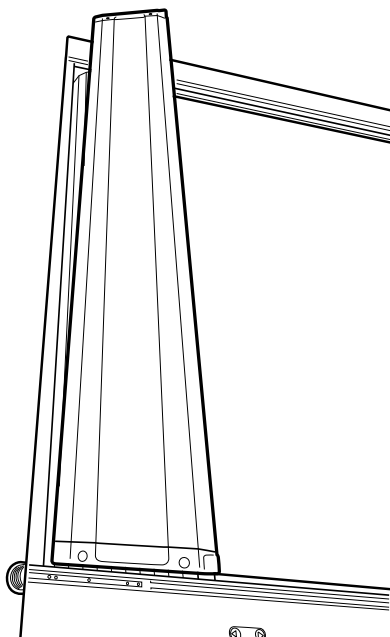

Using countersunk screws provided, line up end cap holes to the threads on the side rail.
Fasten to 3nm torque. Repeat to the other side.

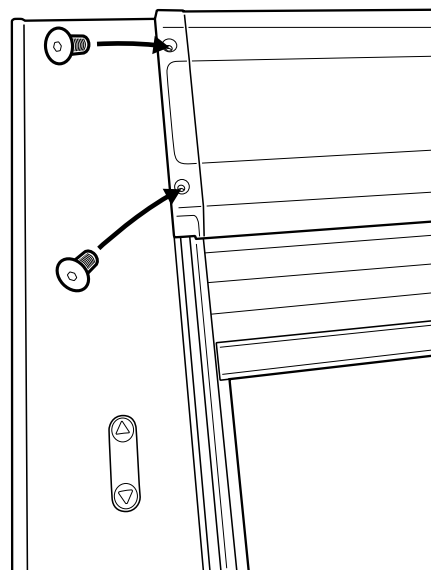

Apply 3M primer provided around all side rail holes.

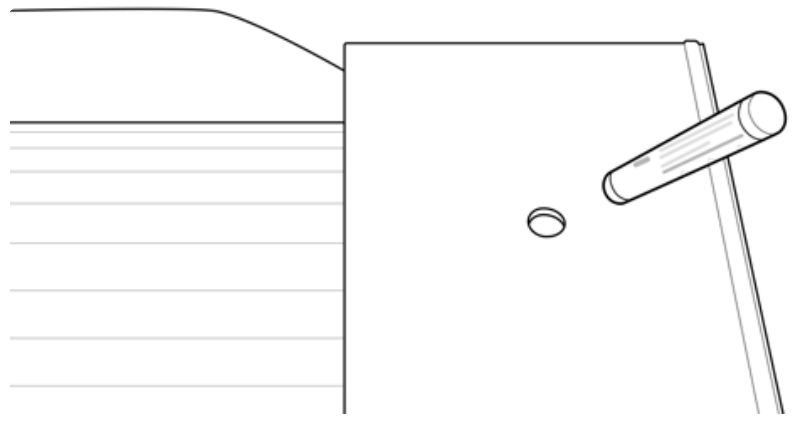

Peel away backing from foam sealant and stick to side rail. Repeat on all 5 holes.

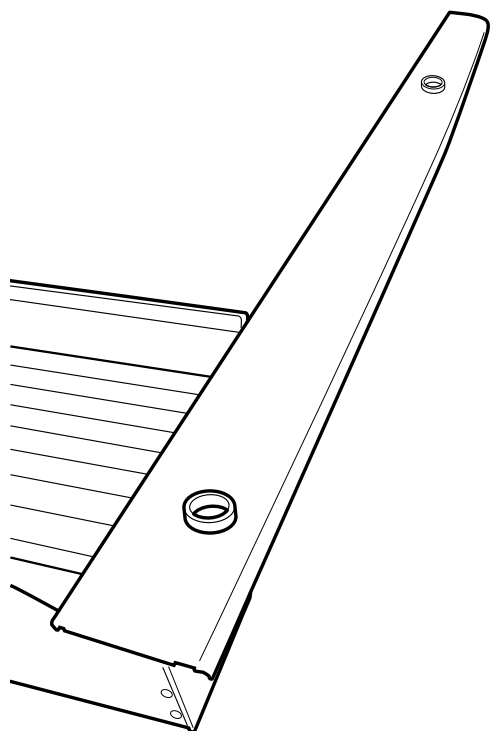
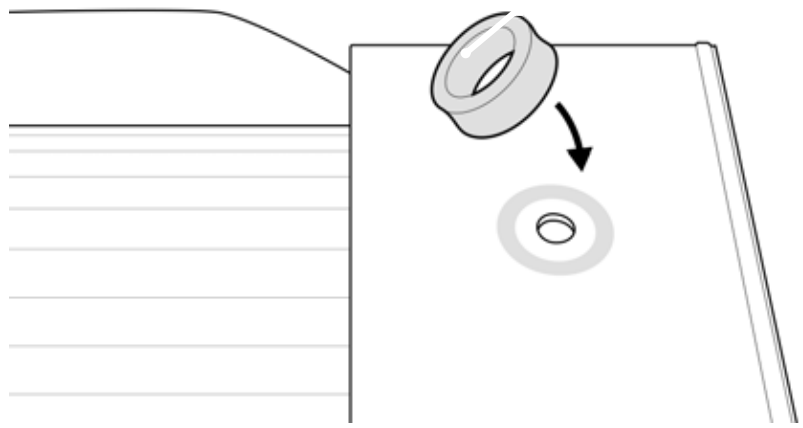

Remove and retain M6x20 Allen head bolt, M6 spring washer and M6 large washer.

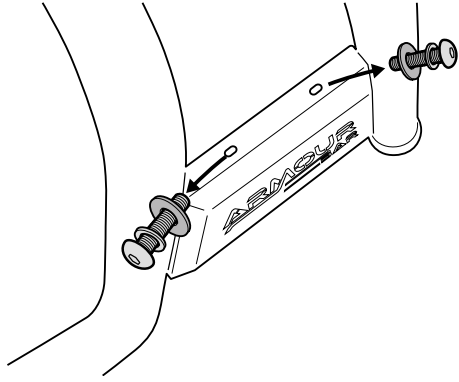

Remove back cover for side plate indicated.

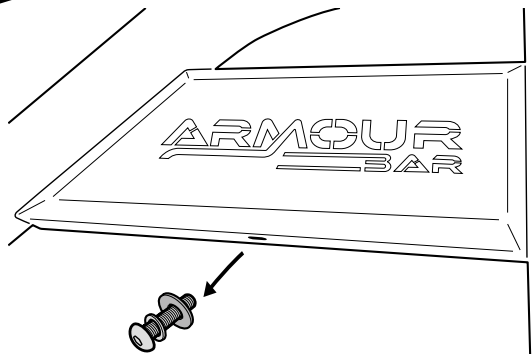
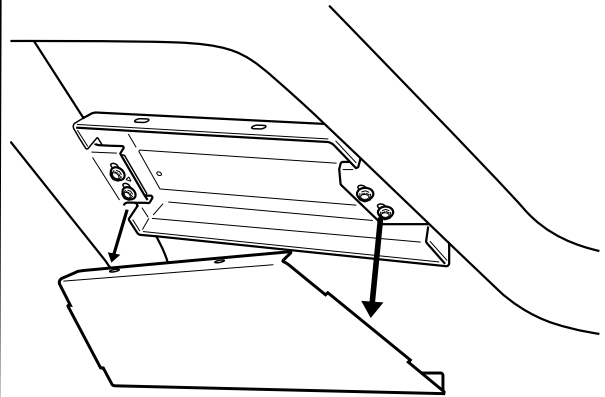

Repeat above step to the other side.

Loosen the bolts indicated.

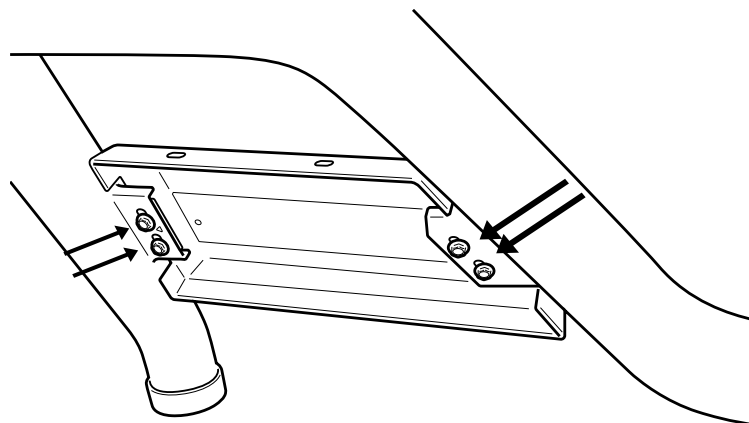

Repeat above step to the other side.

**Feed the brake light loom through the allocated side rail hole.
Place Sportsbar on Roll R cover.**

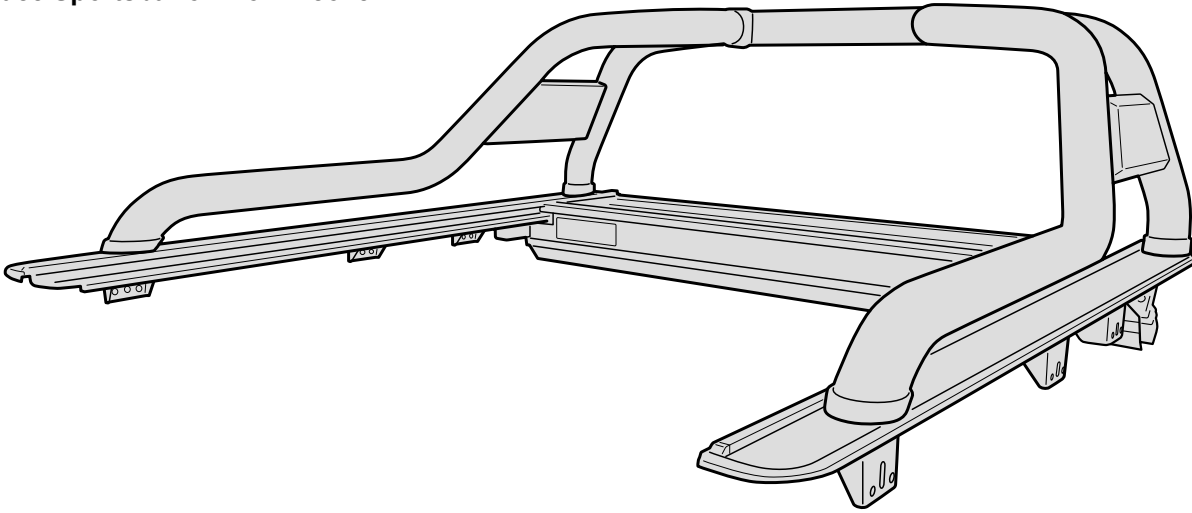

**Loosely fasten sports bars to roll r cover side rails using
M8 x 40mm Allen head, followed by M8 spring washer and
m8 flat washer. Repeat to all other legs.**

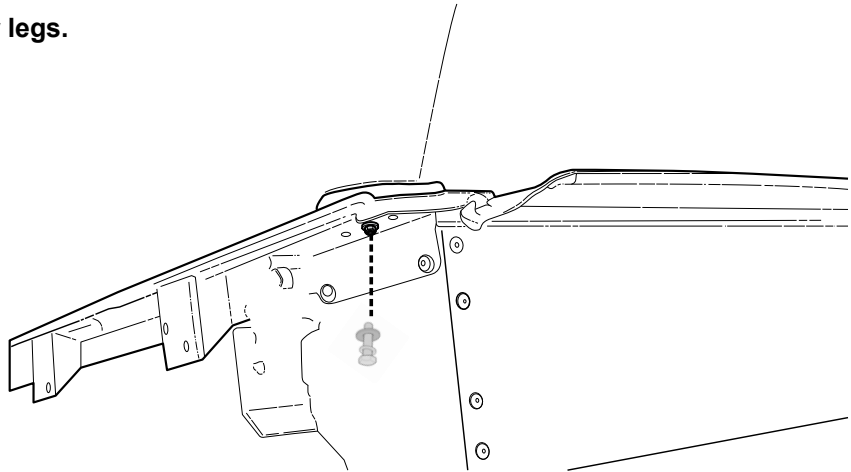

**Center the sports bars on the roll top and fasten tight
the front legs of the sports bars only.**

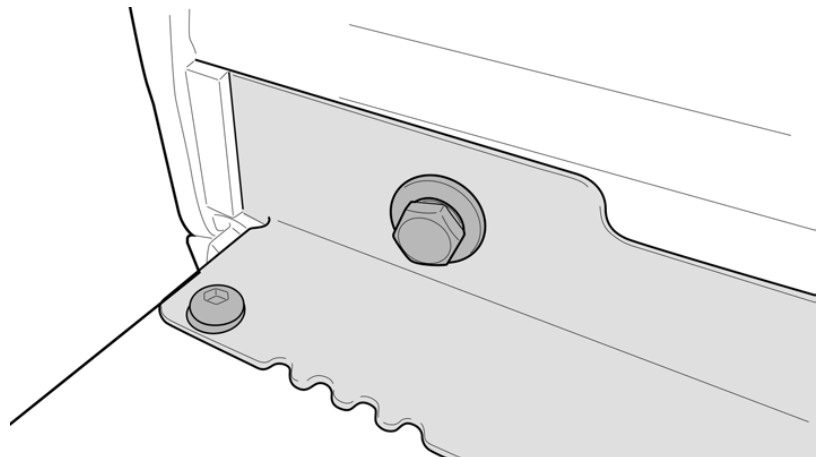

Place the Roll-R-Cover unit on to Ute bed.

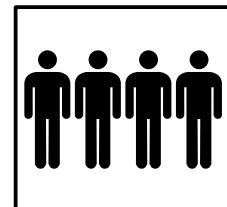
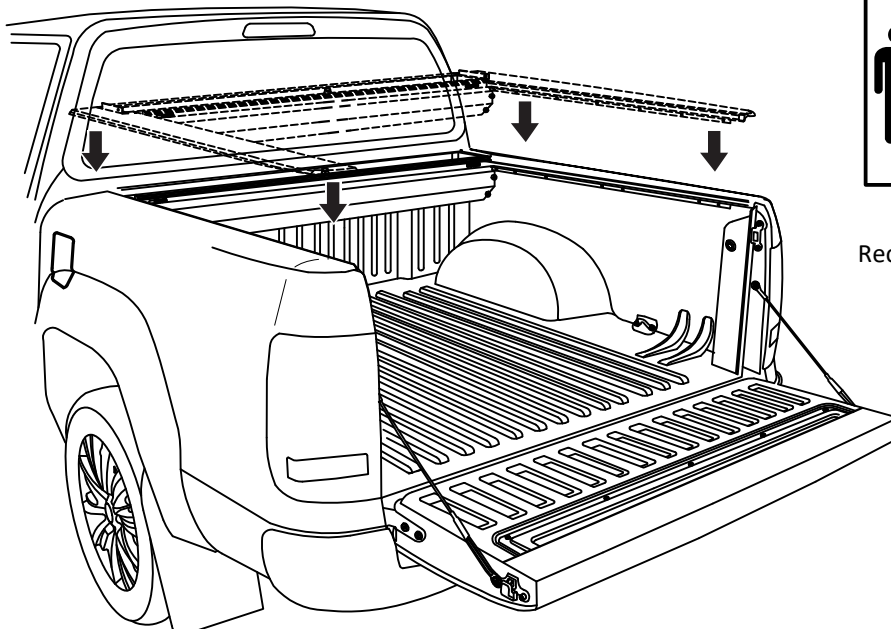

4 People
Recommended for lift

With care, pull out any side rubber that has folded under the side rail.

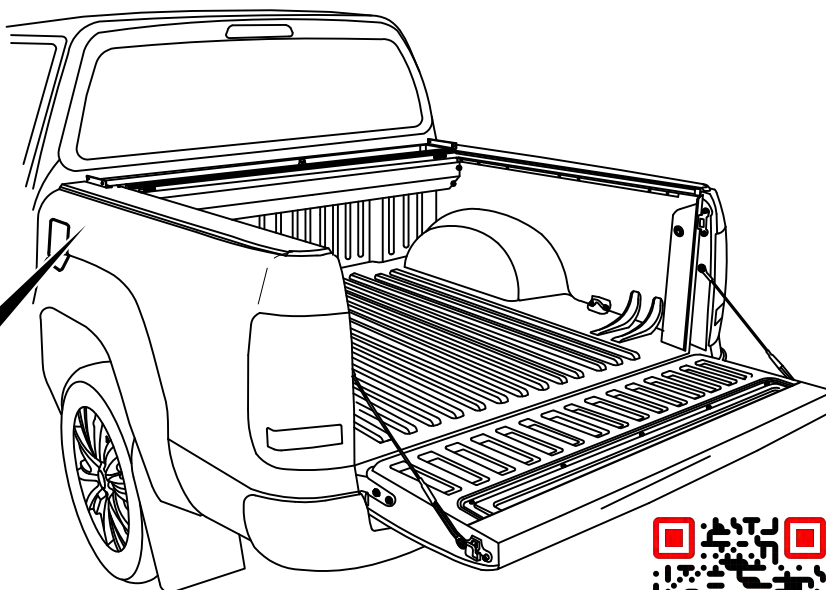

LHS & RHS

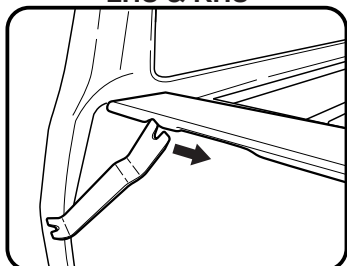

 VISUAL TIP

With the tailgate up (Closed position), Pull left & right hand side rails towards the tailgate, stopping short by 5mm between tailgate and side-rail end-cap.

5mm

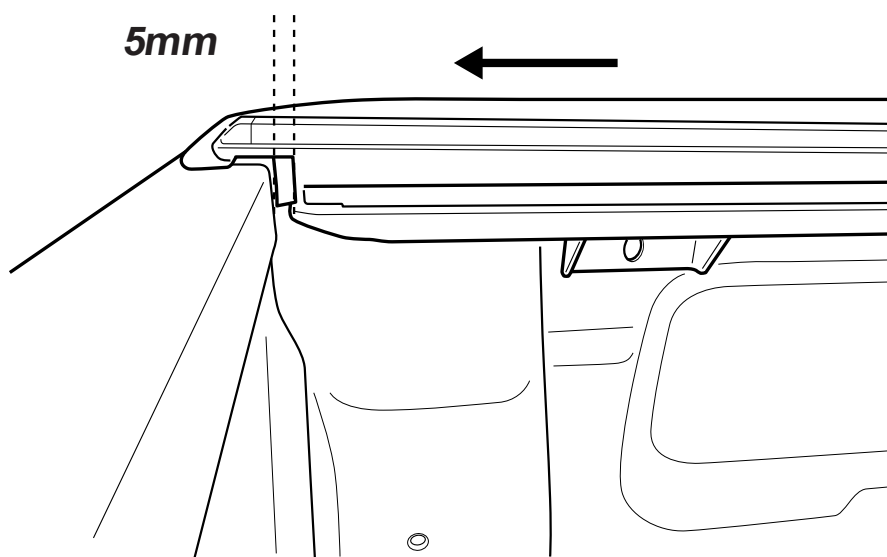

 VISUAL TIP



Foam compressed to 5mm when tailgate is closed.

Gap between tailgate and side-rail end cap to be 5mm.

Foam seal
Side rail end cap

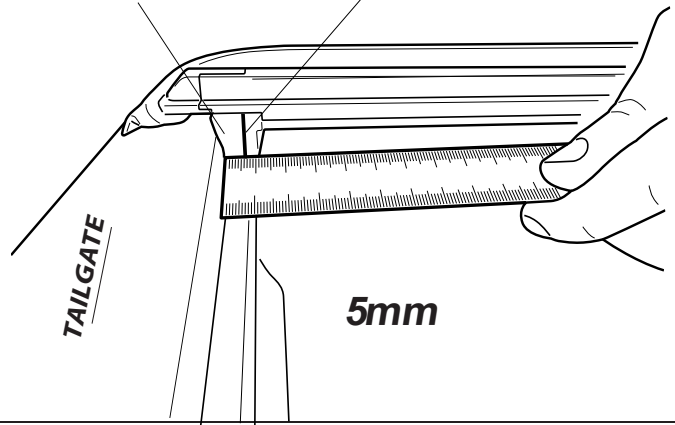

Foam compressed to 5mm when tailgate is closed.

1. Rear brackets elongated hole will line up with the rear most thread in the body as indicated.
2. Feed M8 x 25mm hex head bolt followed by M8 spring washer and M8 flat washer through bracket and loosely fasten to the thread of the ute bed.

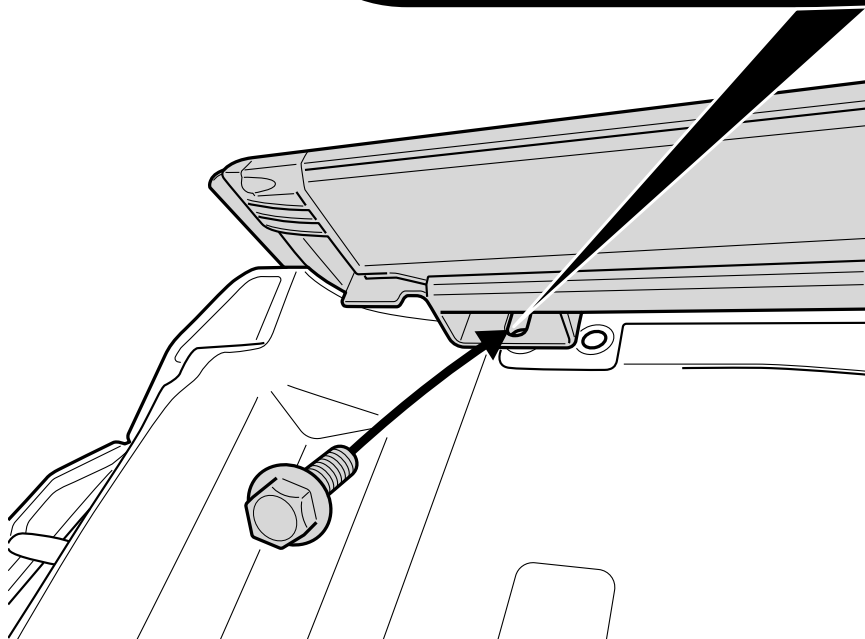
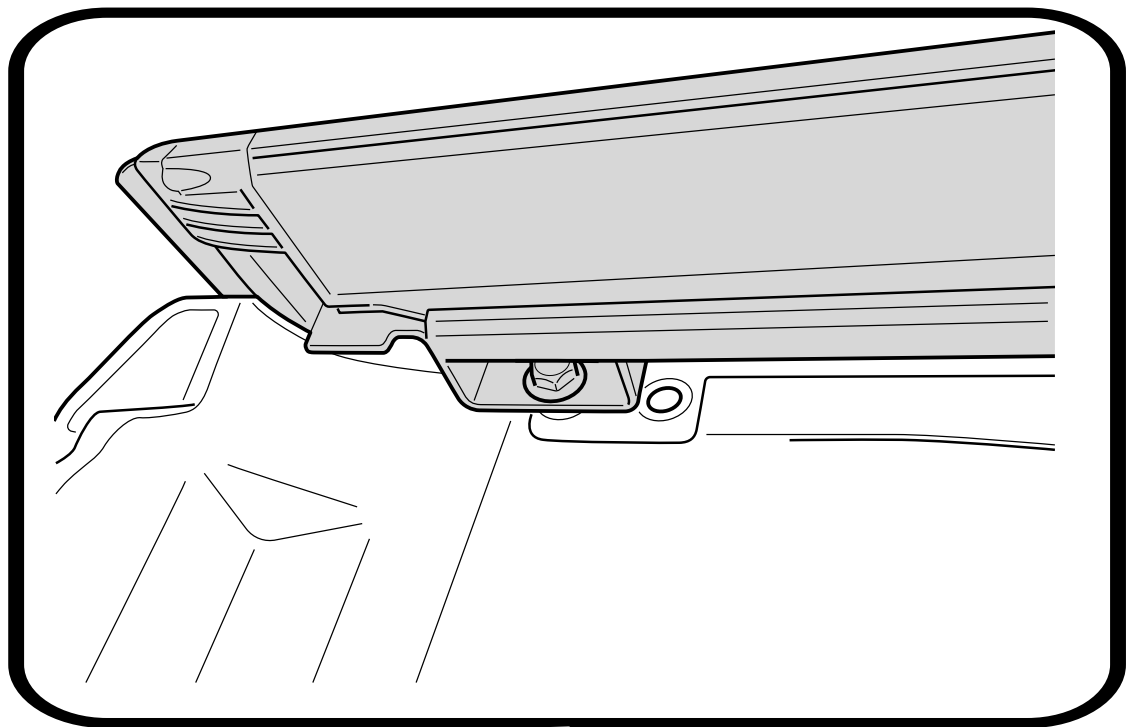

Position clamp behind the inner top lip of the bed rail and the center elongated hole of the side rail mounting brackets. Repeat to other side.

Ensure the M8 nut is in the indicated slot of the clamp

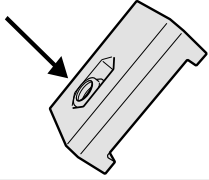

Fasten clamp loosely into position using M8 washer, M8 spring washer and M8 x 35mm bolt.

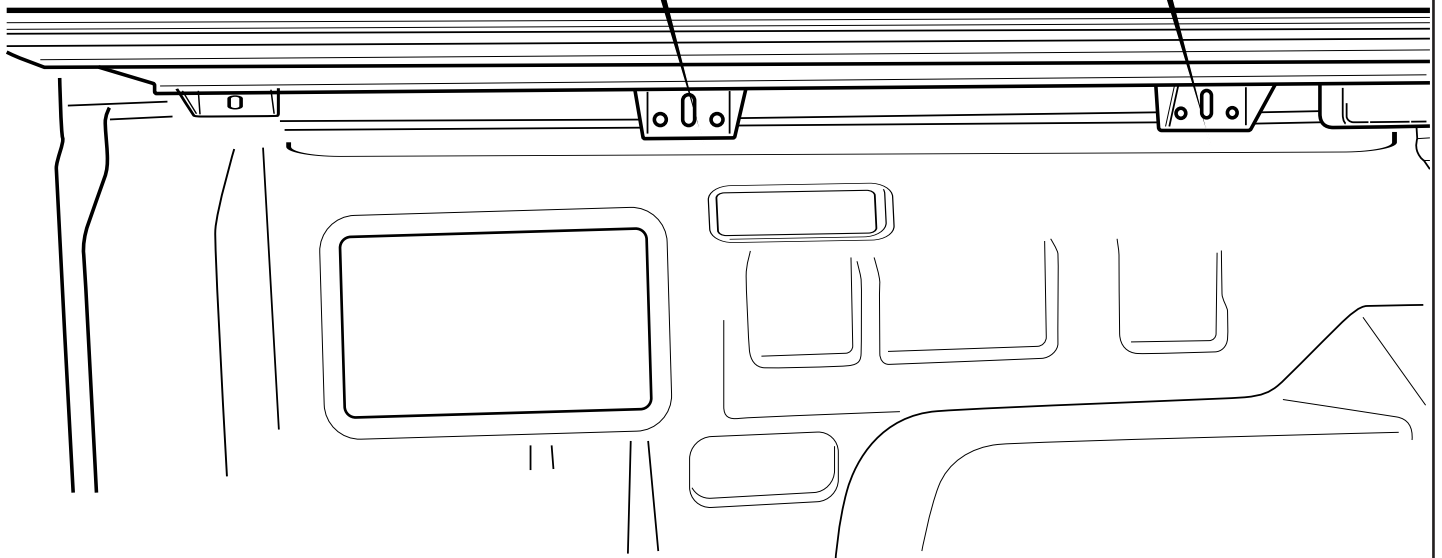
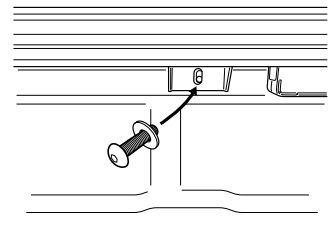

Please follow the steps in order starting with point 1.

1. With assistance apply down pressure to the side rail surface. Keeping that position, now fasten the M8 x 25mm hex bolt to 8Nm torque.
2. Making sure to push clamps up as far as possible into the inner rail of the tub and fasten bolts to 10Nm torque.
3. Making sure to push clamps up as far as possible into the inner rail of the tub and fasten bolts to 10Nm torque.

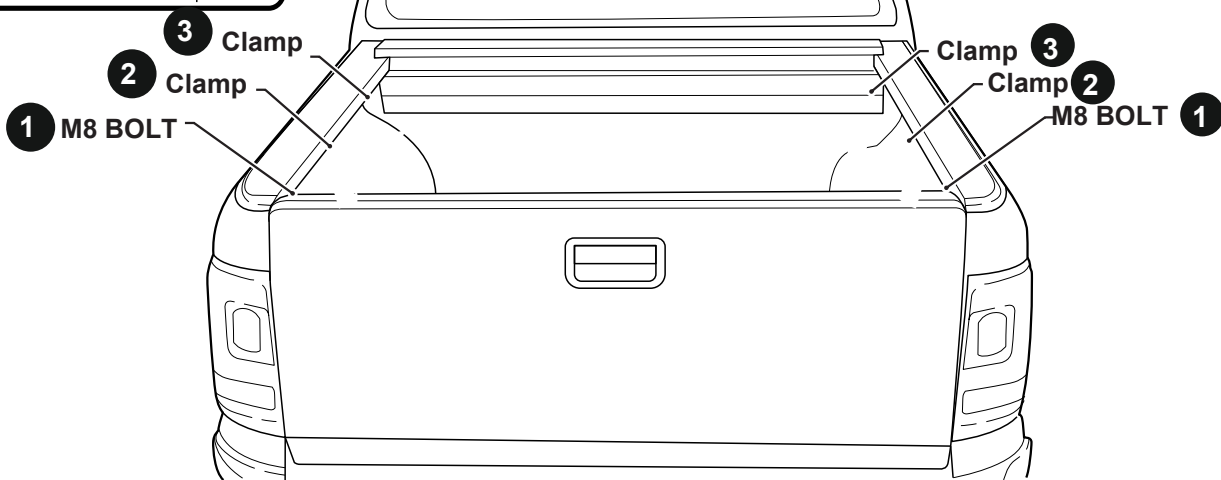
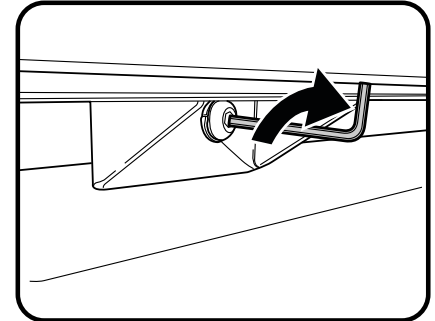
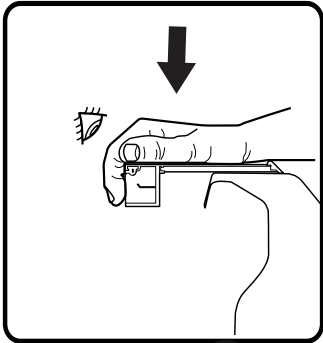

Side rail rubber to sit 1mm below from the top of the tailgate in the closed position.

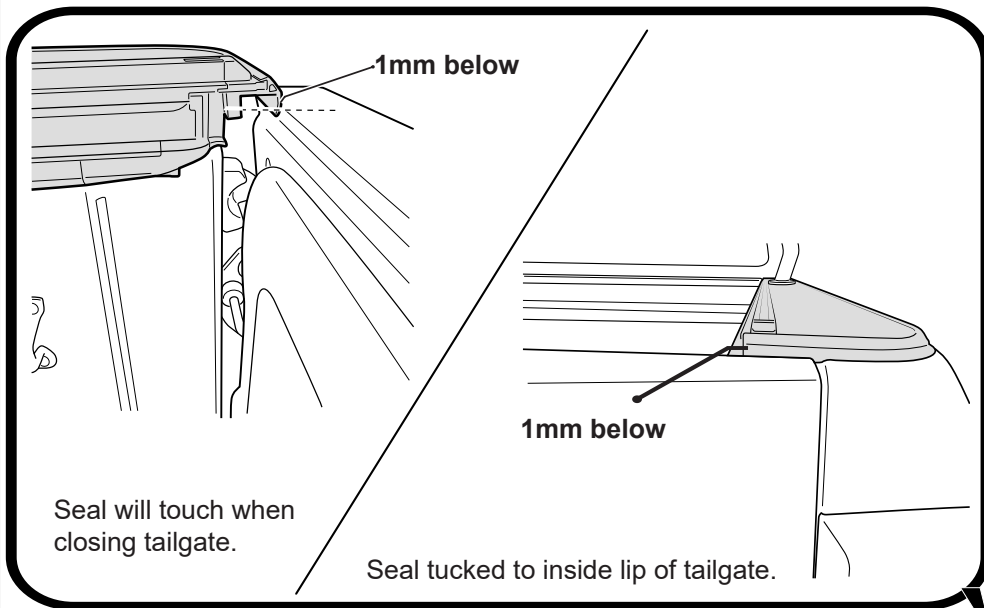

If required M8 hex bolt can be loosened to push the side rails further down or lift up. Fasten bolt to 8Nm torque.

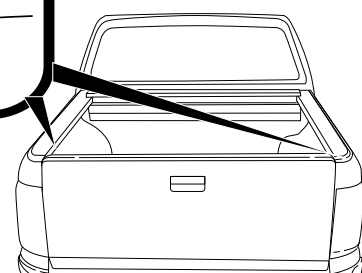
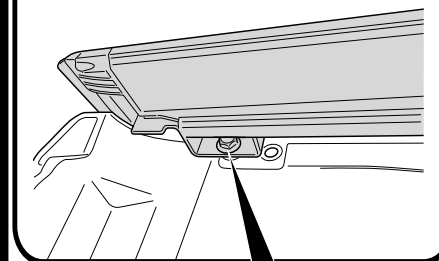

1. Clean area with non oil based cleaner, ie alcohol wipe.
2. Apply clear protective tape to left and right top corners of the tailgate as indicated.

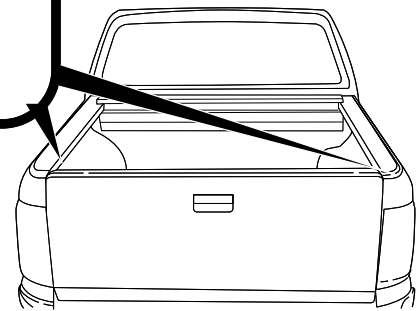
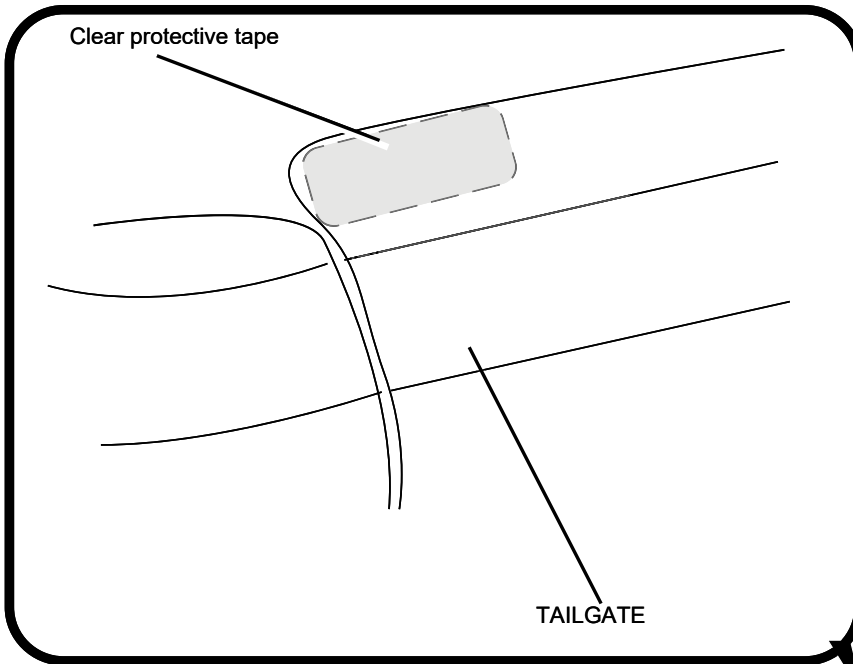
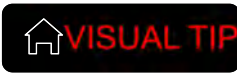
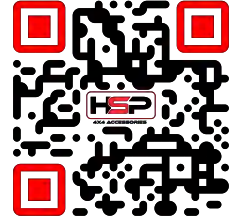

Install front drain pipes through pre-drilled holes of the canister. (RHS/LHS)



Note: With care push tube in. Gently pull the tube back so it seals correctly against the front panel of the tub.



VISUAL TIP

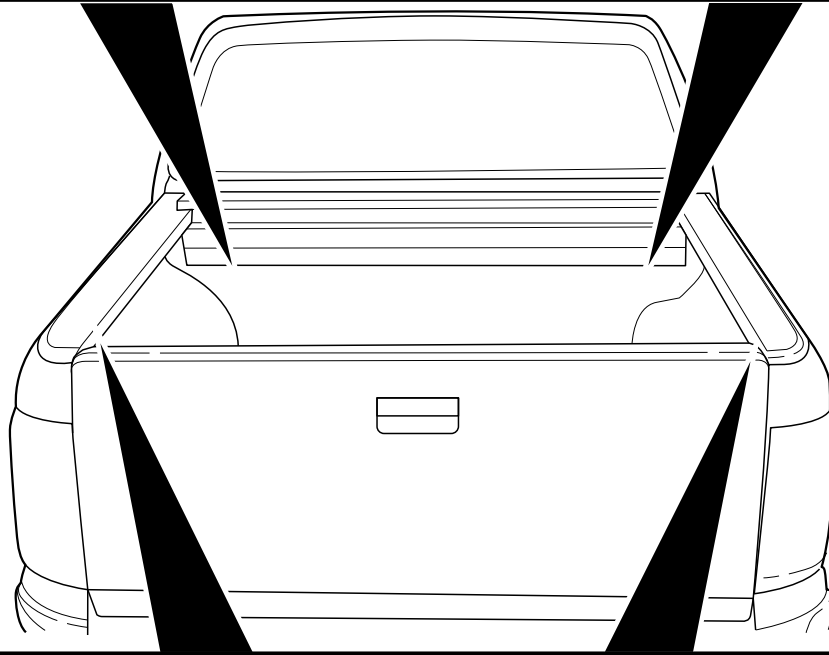
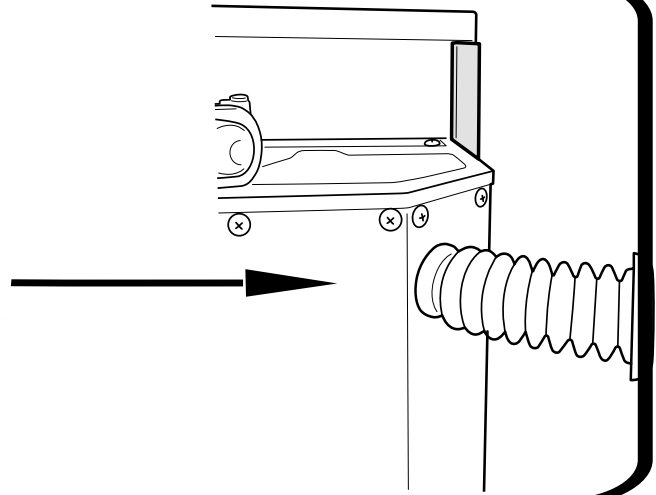
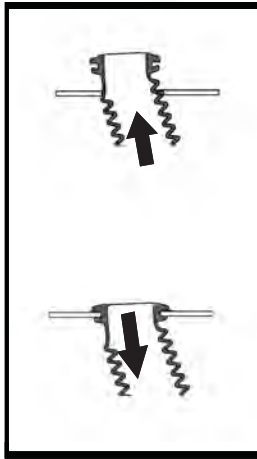

Note: With care push rear pipe in. Gently pull the pipe back so it seals correctly within the side rail channel.

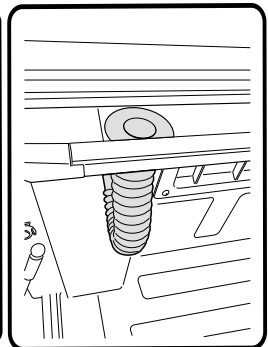
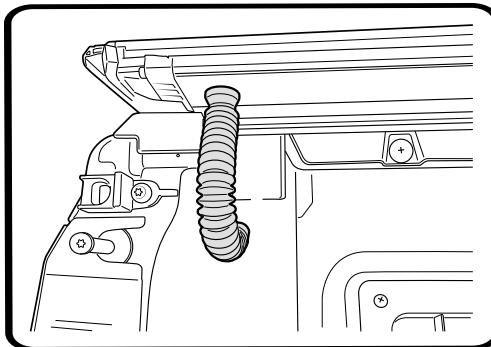
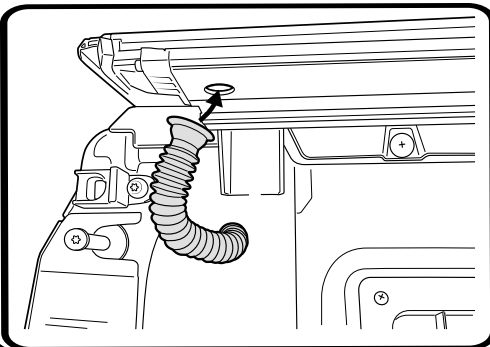
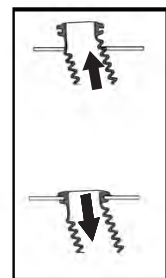

Install rear drain pipes through pre-drilled holes of the siderails. (RHS/LHS)

Fasten both rear legs of the sports bars to to 3nm torque.

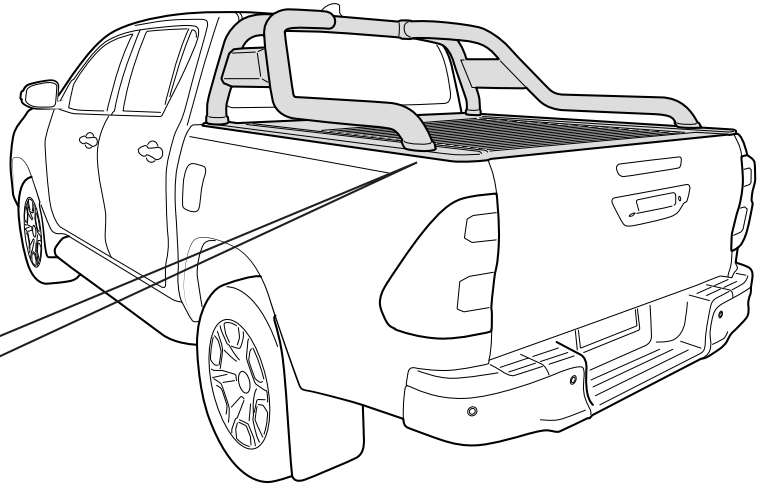
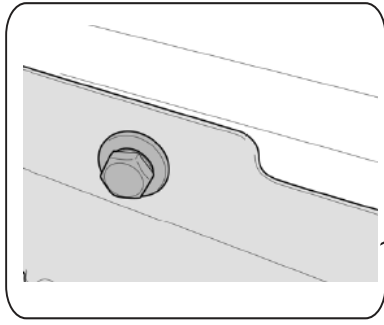

Fasten the bolts indicated.

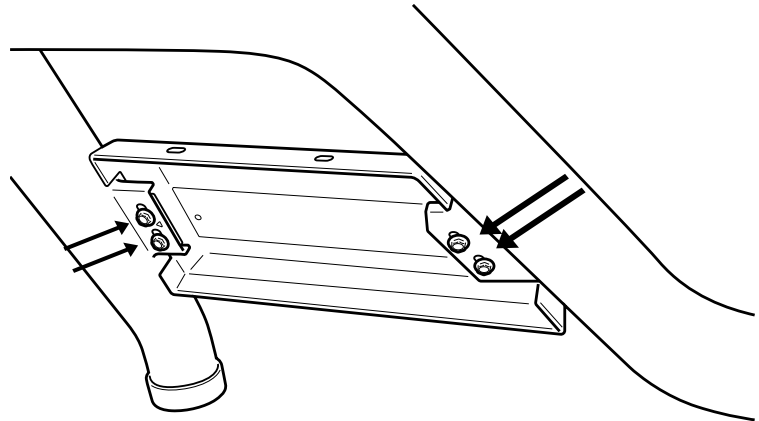

Repeat above steps to the other side.

Align back cover for side plate as indicated.

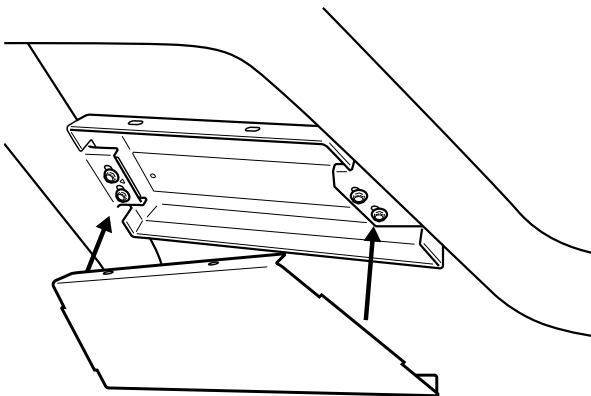

Fasten into position using M6x20 Allen head bolt through M6 spring washer and M6 large washer.

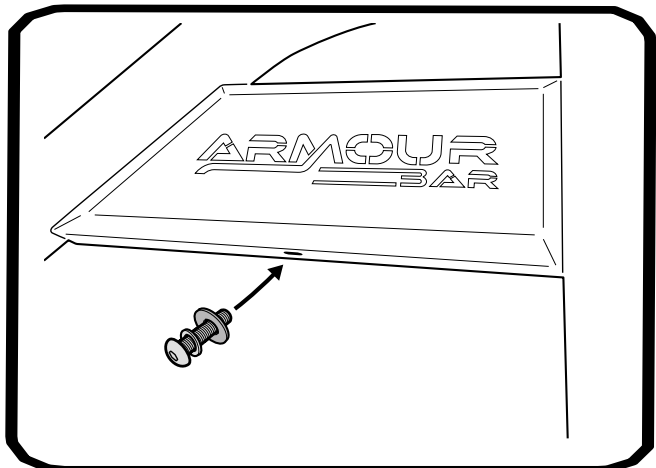
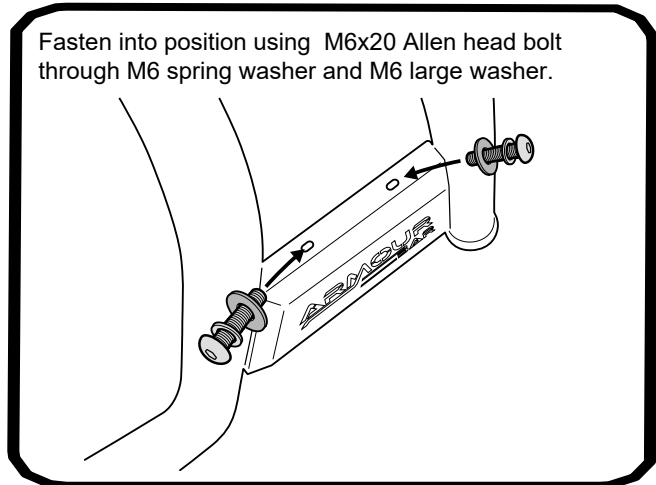

Repeat above steps to the other side. Re-connect the brake light loom to the vehicle.

- a. Connect Battery loom S2.75 to Receiver loom.
- b. **Carefully** connect S3-CL-PATCH to Receiver loom.



Align connectors carefully to avoid pushing pins out.

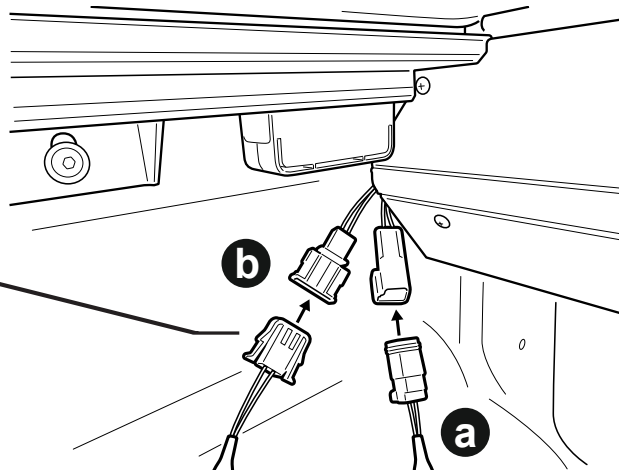

Carefully connect CI-Loom-Long to S3-cl-patch.

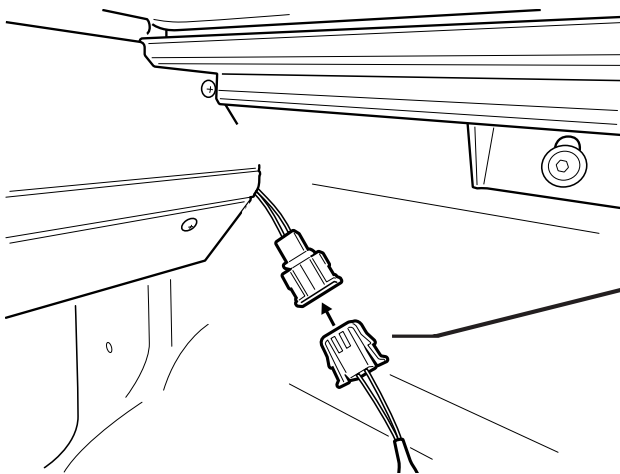

Align connectors carefully to avoid pushing pins out.



Operating instructions:

Press unlock on vehicle key fob to activate controller.
 When vehicle is unlocked the side rail sensor buttons will be active to control.
 When vehicle is locked the side rail sensor buttons will be inactive.

Using factory key fob to operate:

Pressing unlock twice on the factory key fob within 4 seconds, will activate the roll r cover to open.
 Pressing lock twice on the factory key fob within 4 seconds, will activate the roll r cover to close.

Vehicle proximity:

Tapping the proximity twice to open or lock the car door will act exactly the same way as the key fob being pressed twice.

Touch & let go to open, touch & let go again to pause.

Touch & let go to close, touch & let go again to pause.

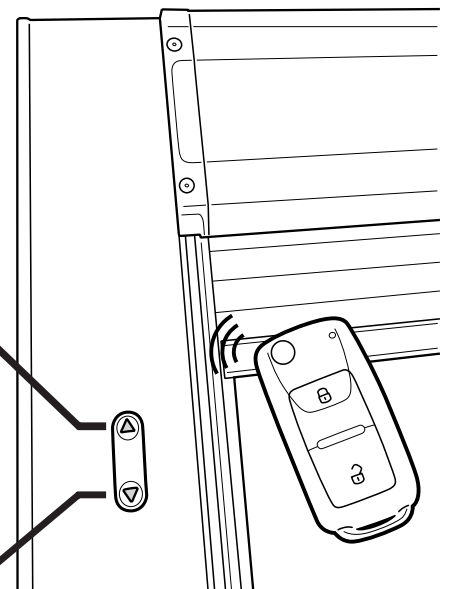

NOTE: 1. To wear in the Roll R Cover please fully open & close the cover approximately 15 times after install is complete.

2. Set your vehicle locking system to unlock all doors with one press of the factory remote unlock button. This setting can be found in your vehicle settings.

Trouble shooting visual tips:

side rail Parallel test

