



# **Important Information!**

**Please note that with the box of the Roll R Cover, there is a service kit that includes:**

- A User Guide**
- Specific Lubrication**
- A Servicing Guide**
- A Warranty Guide**

**This must be handed over to the end user in order for them to register their warranty and understand the servicing requirements.**

**ROLL. R. COVER<sup>®</sup>**  
**SERIES 3**



# INSTALLATION INSTRUCTIONS

**Vehicle Model: FORD RANGER - NEW  
GENERATION 07-2022 + WITH FACTORY  
SPORTS BARS**

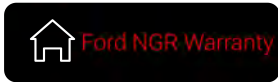

**INSTALLATION TIME:** 2 hours and 45 minutes (Approximately)

<b>IMPORTANT</b>	<ul style="list-style-type: none"> <li>Do not stand/sit or rest heavy objects on Roll R Cover</li> <li>Humans or animals are not to be under the closed cover at any given time</li> <li>Tonneau Cover is not dust or water tight</li> <li>If contact with volatile chemicals occur, clean Cover with mild detergent and water solution</li> <li>Next Gen Ford Ranger Warranty Additional Information.</li> </ul> <div style="text-align: center; margin: 10px 0;">  </div> <div style="text-align: center; margin: 5px 0;">  </div> <div style="margin-top: 10px;"> <p><b>If you are self installing: Please scan QR code to access important information.</b></p> <p><b>If you are fitting on behalf of someone: Advise them that they must scan QR code to access important information at hand over.</b></p> </div>		
<b>Care Instructions</b>	<ul style="list-style-type: none"> <li>Read Instructions fully before commencing installation.</li> <li>Clean Cover with a mild detergent and water solution</li> <li>Do not use abrasive cleaners or solvents</li> <li>Refer to manufactures instructions applicable to power drill.</li> <li>Protect Tub floor against scratches during installation process.</li> </ul>		
<b>Maintenance</b>	Refer to Maintenance instructions.		
<b>Tools Required</b>	<ul style="list-style-type: none"> <li>Pen / Marker</li> <li>Centre Punch</li> <li>Drill &amp; Drill bits</li> <li>Caulking Gun</li> <li>Silicon - Non Acetic</li> </ul>	<ul style="list-style-type: none"> <li>Scissors &amp; Knife</li> <li>Spanner &amp; Socket</li> <li>Tape measure</li> <li>Holesaw</li> <li>Filing tool</li> </ul>	<ul style="list-style-type: none"> <li>Soapy water solution</li> <li>Allen Key set</li> <li>Screw driver</li> <li>Rust Inhibitor</li> <li>Trim Removal Tool</li> </ul>

# BOX CONTENTS

## LEFT & RIGHT SIDE RAIL

S2.5-DC-AE-002ps-NGR42



S2.5-DC-AE-003ds-NGR42

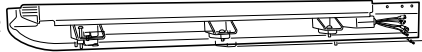

## CANISTER ASSEMBLY

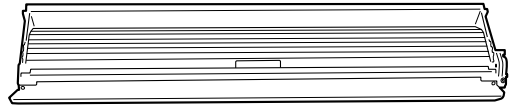

S3-DC-AF-NGR-001/002

## CANISTER TOP COVER



S2.5-DC-AE-005 -NGR

## NGR42R SPECIFIC KIT

<p>COVER END CAPS</p> <p>S2.5-DC-PI-004ps S2.5-DC-PI-004ds</p>	<p>COUNTERSUNK SCREW Qty - 4</p>	<p>Drainage pipe Qty - 2</p>	<p>BATTERY LOOM S2.75</p>	<p>CABLE TIE Qty x 16</p>	<p>CL-LOOM-SHORT</p>
<p>NGR-PATCH</p>	<p>1 NOTCH SPACER Qty - 4</p>	<p>M8 NUT Qty - 4</p>	<p>SIDERAIL CLAMP Qty - 4</p>	<p>M8 x 45mm Qty - 6</p>	<p>M8 WASHER Qty - 8</p>
<p>M8 SPRING WASHER Qty - 6</p>	<p>M6 x 25mm Hex head bolt Qty - 2</p>	<p>M6 WASHER Qty - 2</p>	<p>M6 SPRING WASHER Qty - 2</p>	<p>BLACK M8 x 30mm Qty - 6</p>	<p>LEFT &amp; RIGHT BRACE BRACKET</p>
<p>BLACK M8 x 25mm Qty - 4</p>	<p>NGR-FBA QTY - 1</p>		<p>BLACK M8 WASHER Qty - 4</p>	<p>M8 RUBBER WASHER Qty - 4</p>	
<p>LHFC Front Left Cup Qty - 1</p>	<p>RHFC Front Right Cup Qty - 1</p>	<p>LHRC Rear Left Cup Qty - 1</p>	<p>RHRC Rear Right Cup Qty - 1</p>	<p>NGR-SBB Qty - 2</p>	<p>M6 x 25mm Countersunk Bolt Qty - 2</p>
<p>Rear Drainage pipe Qty - 2</p>					

## TUB PREPARATION

**NOTE:** Instructions may refer to one side of vehicle, repeat steps to the other side.

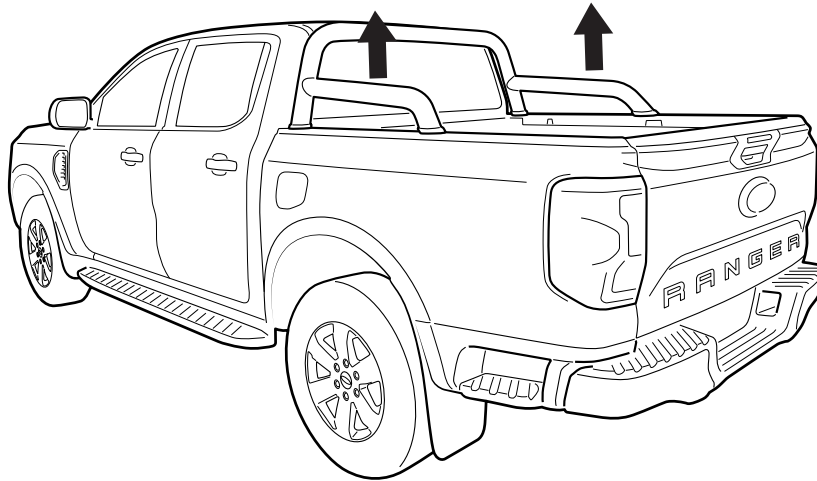

Remove indicated cap to gain access to sports bar bolts.

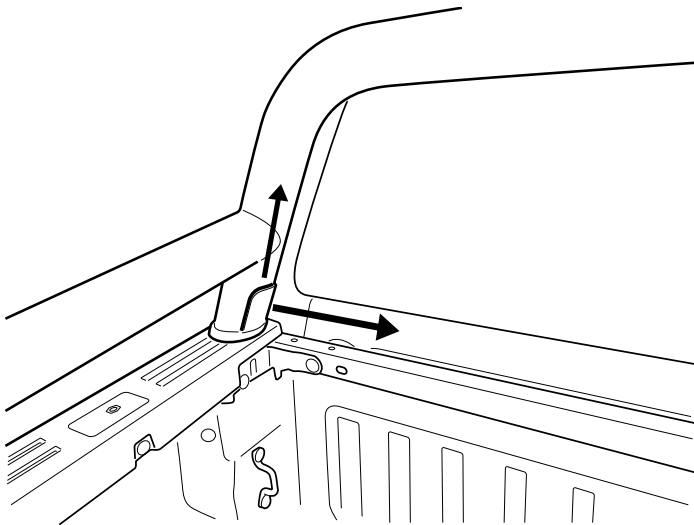

Unfasten and retain bolts.  
**Note:** Record the bolt locations.

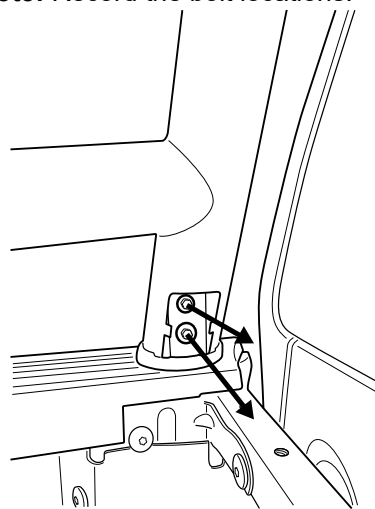

Unfasten and discard rear leg nuts holding the sports bar.

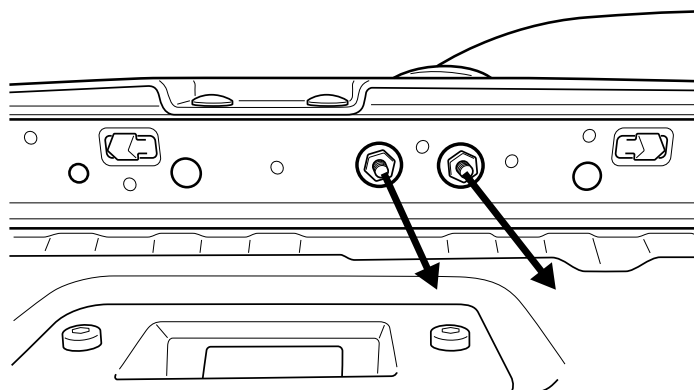

Remove sports bar and retain.

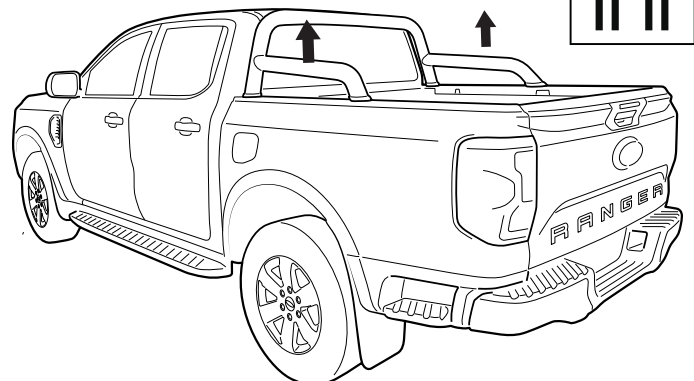



Remove and retain indicated body clips.  
Repeat to the other side.

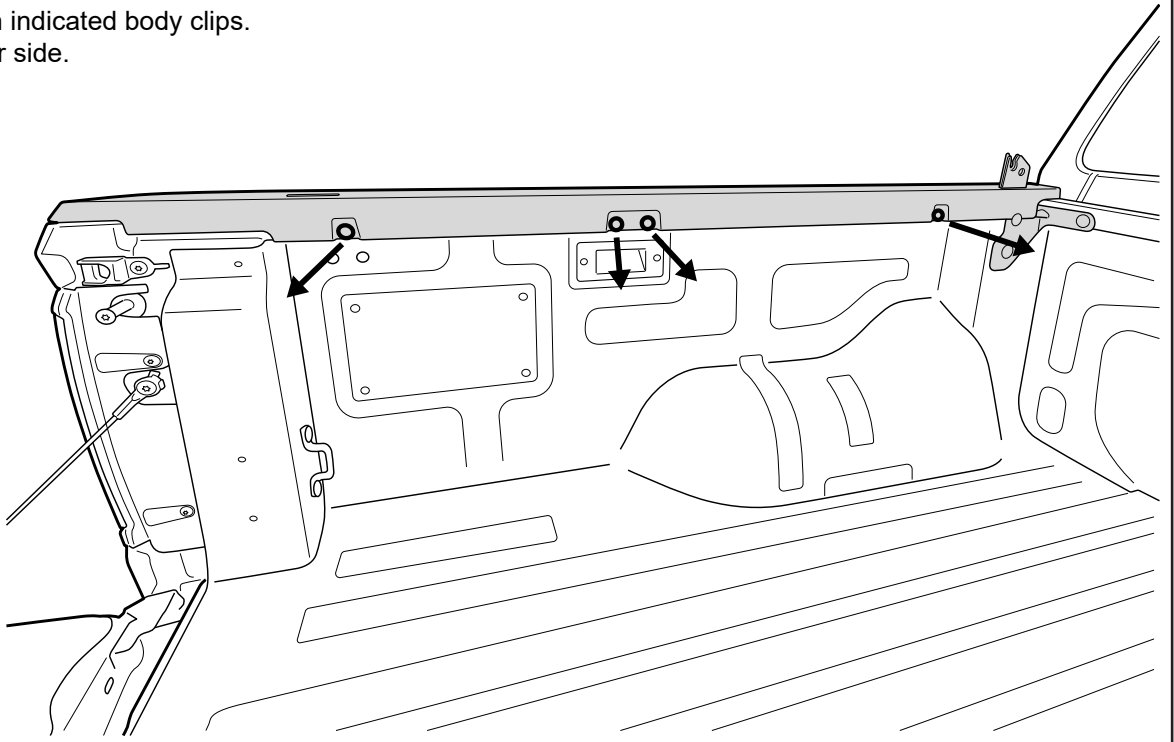

Carefully remove the plastic trim cap from the top of the tub, using assistance if necessary.  
Find the clip that holds the top trim of the tub and press the clips as needed to release the trim from the tub.  
Repeat to the other side.

Trim clips located under  
the tubs inner rail.

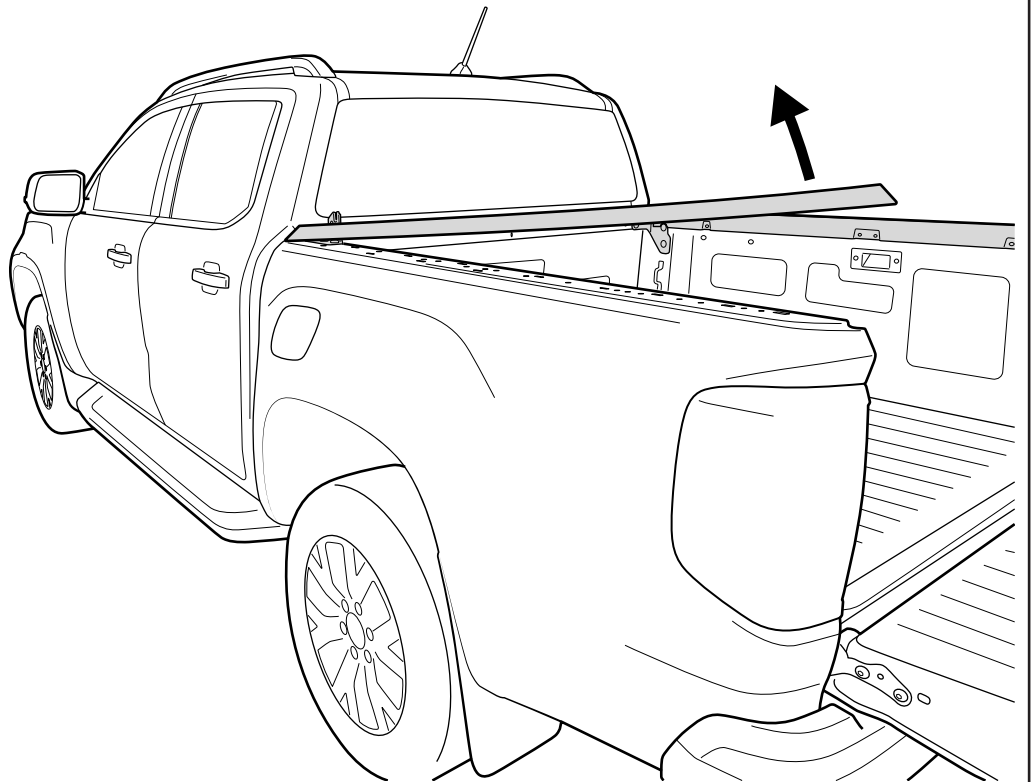
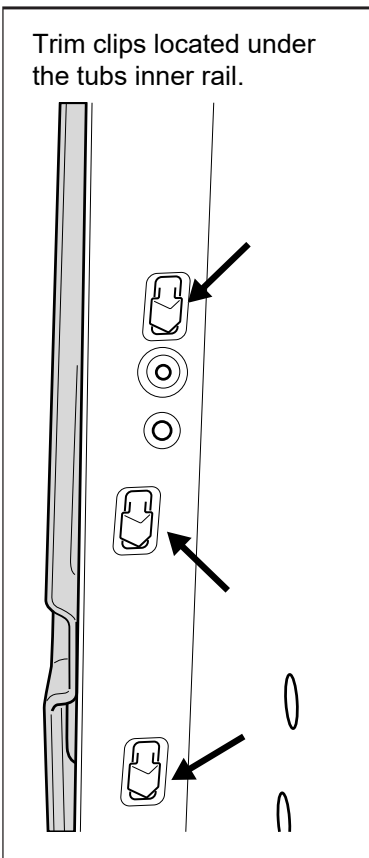

Remove the specified M8 Torx Plus bits and dispose of them.

**IMPORTANT:** When removing the bolts, please use a **(T40 PLUS BIT)** tool. Using a standard T40 tool may cause damage to the bolt head, rendering it difficult to remove.

Repeat to the other side.

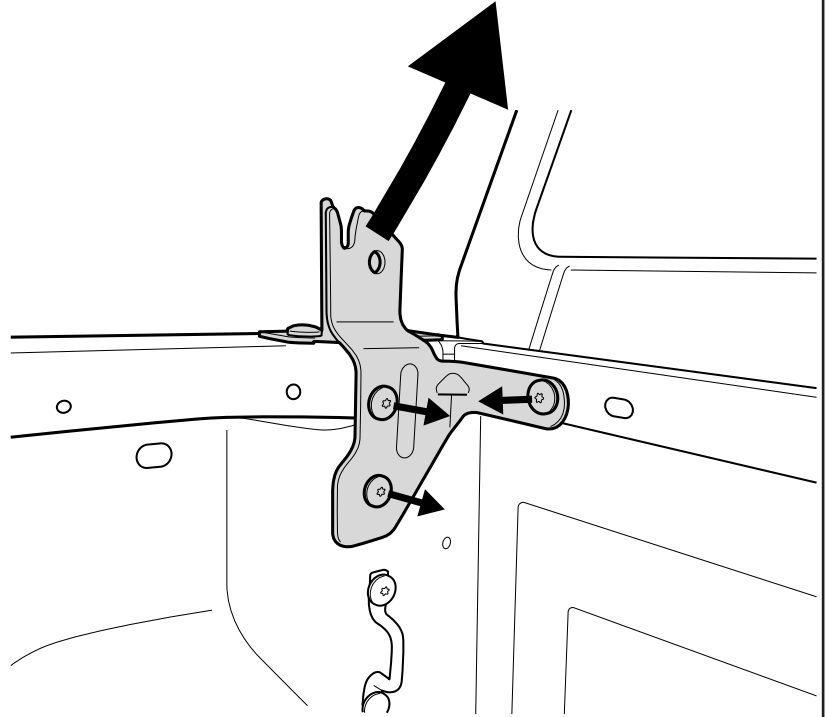
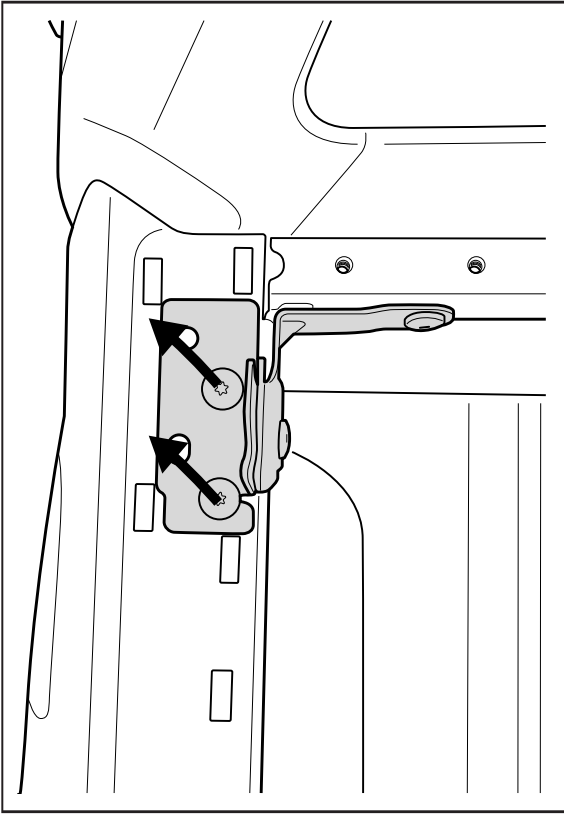

Handle with care as you reattach the plastic trim to the top rail of the tub.  
Repeat to the other side.

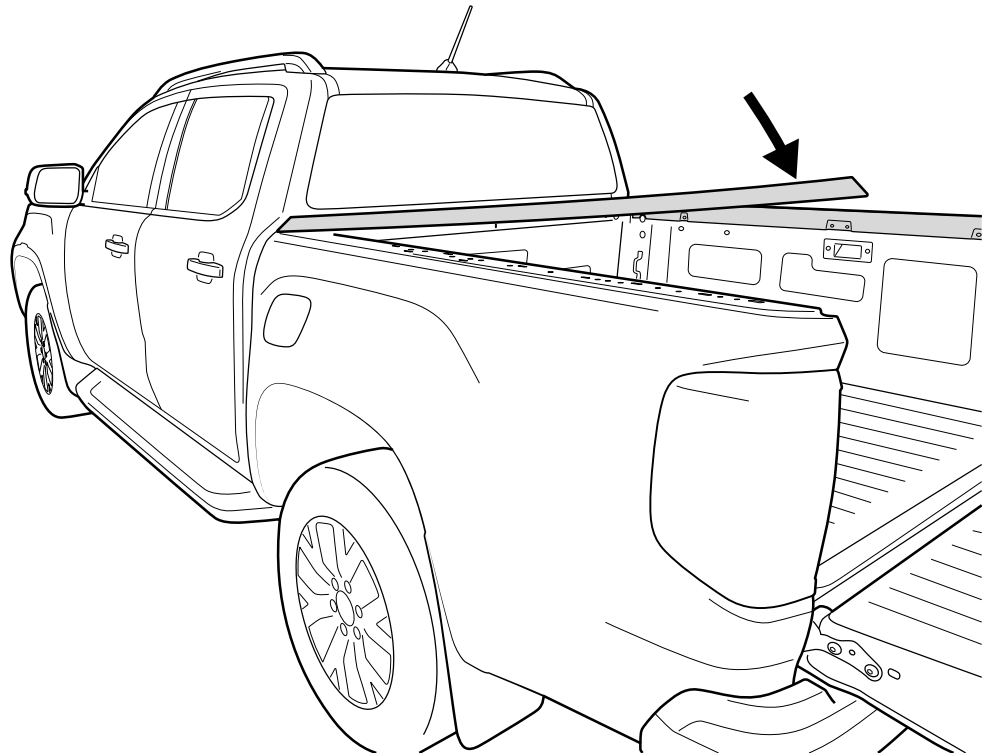

**NOTE:** Following steps are for vehicles fitted with a factory tailgate liner. If no tailgate liner skip to page 6.

Remove and retain indicated screws.



 **VISUAL TIP**

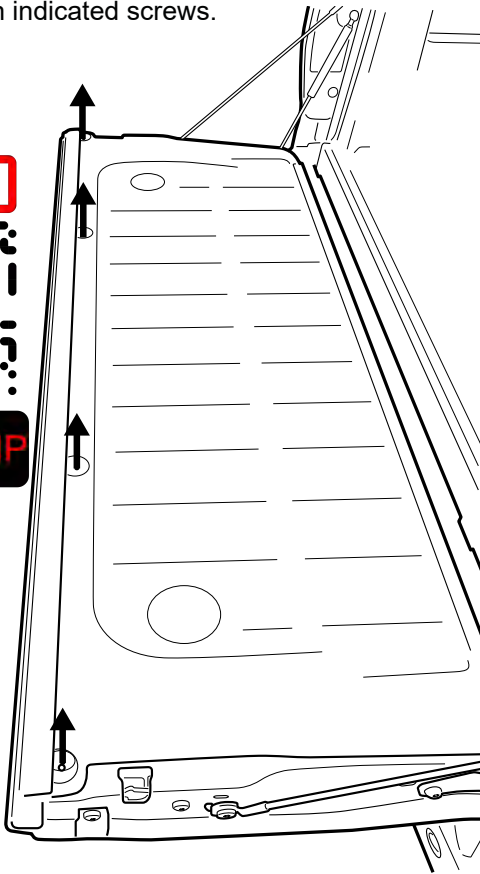

Push the tailgate's top plastic trim to expose the inner measuring guide of the trim.

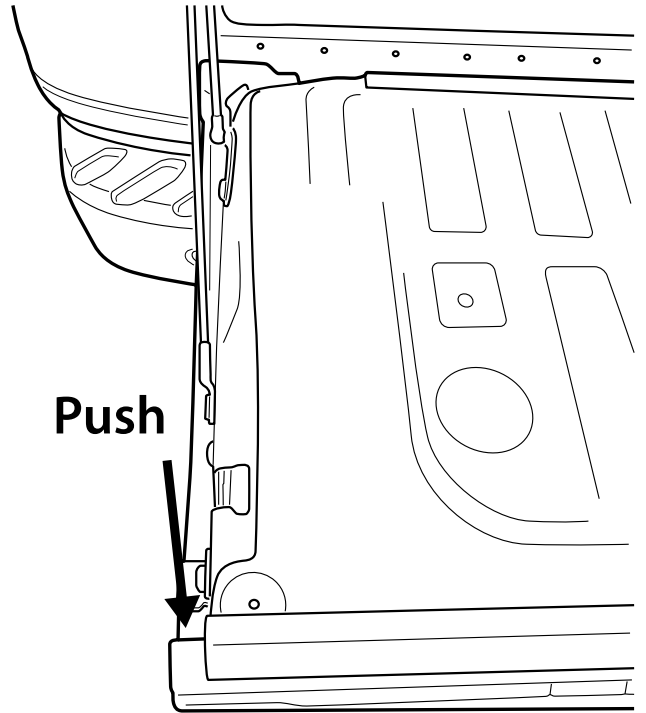

Using a plastic trim removal tool, carefully tuck the rubber molding in to the cavity behind the measuring guide.

Slide plastic trim tool between cavity and rubber molding toward the other side.

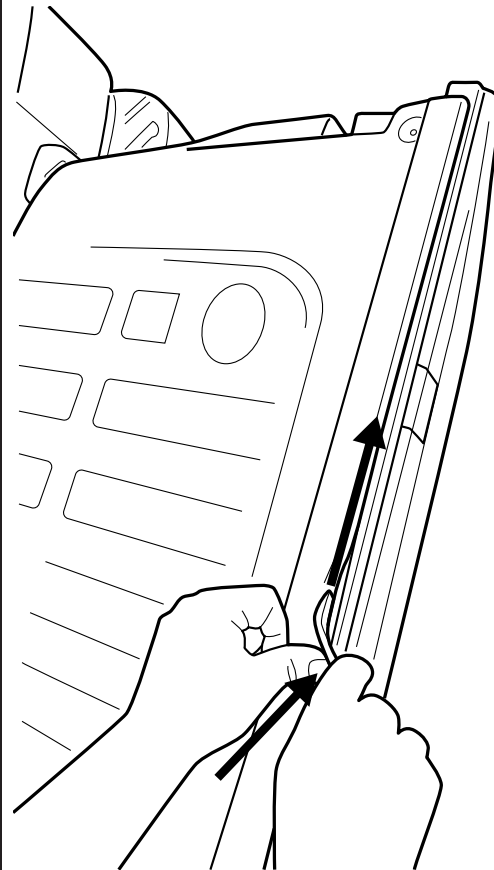
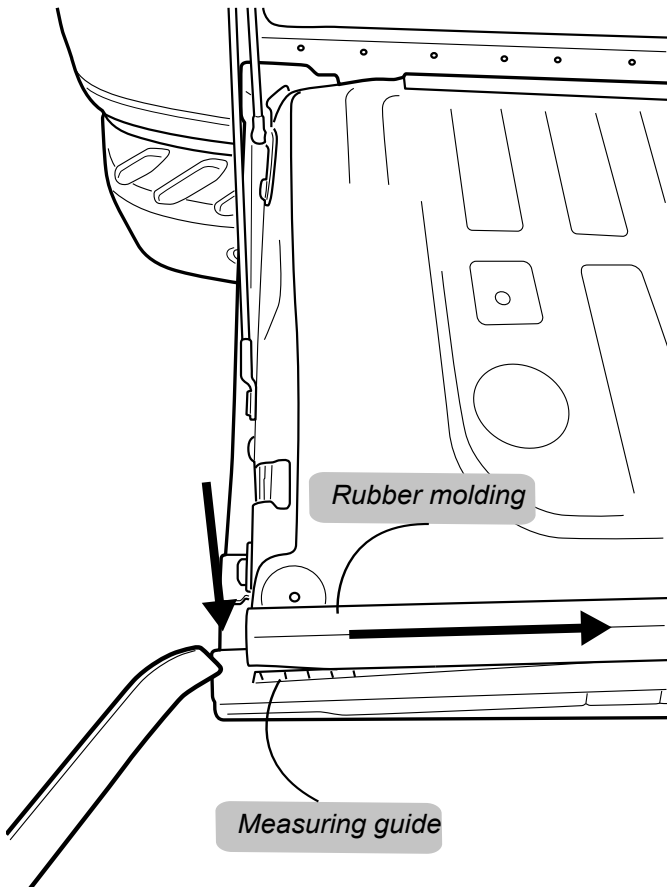

Using retained screws, fasten the tailgate liner in to position.

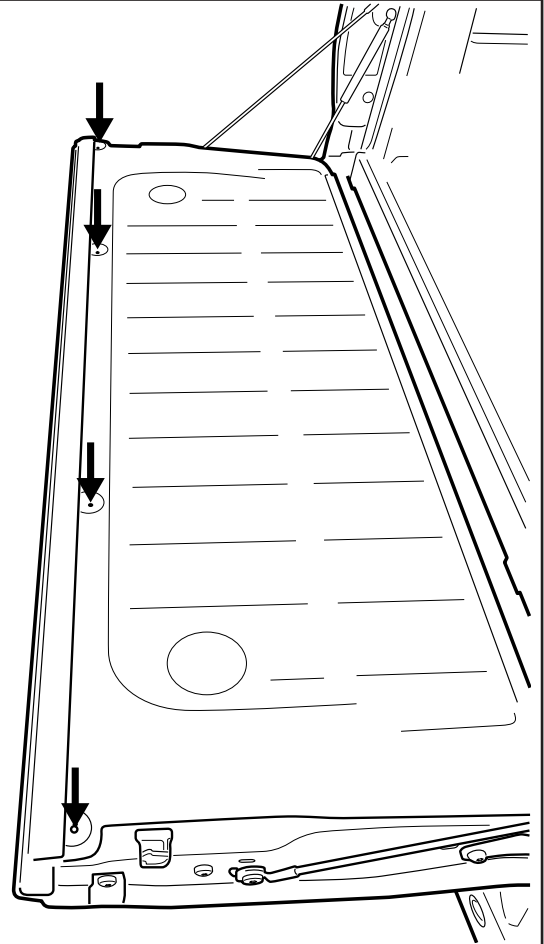

Completed view showing tailgate liners rubber moulding behind the measuring guide.

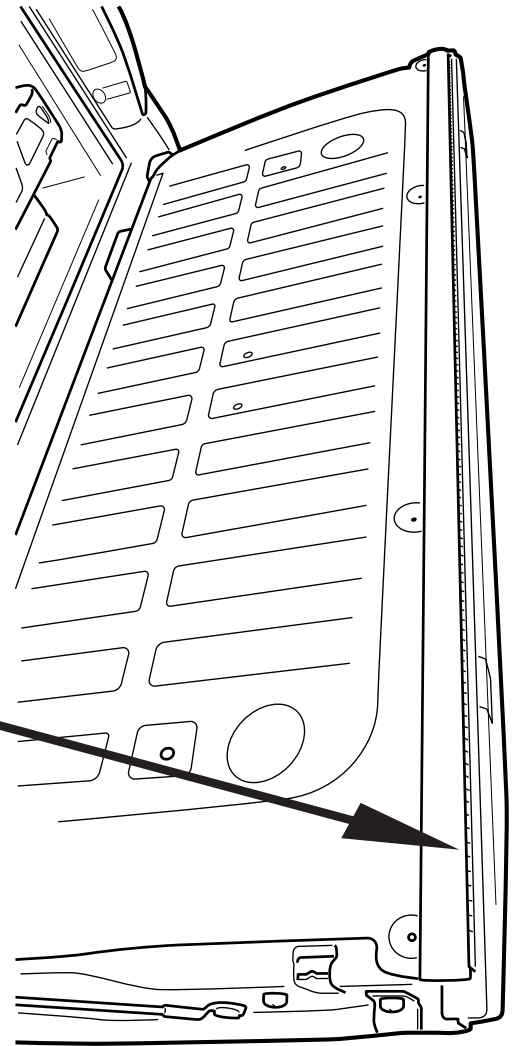
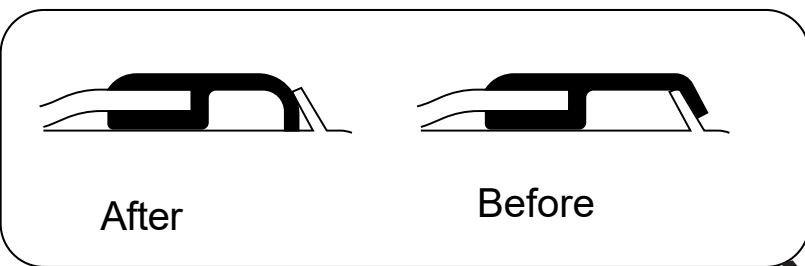

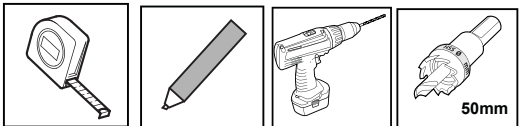

Measure down from top of headboard 180mm & 70mm measuring from the side of the top rail. Repeat to the other side.

Using a 50mm hole-saw drill the liner only as indicated.

NOTE: Only drill the tub liner at this step.

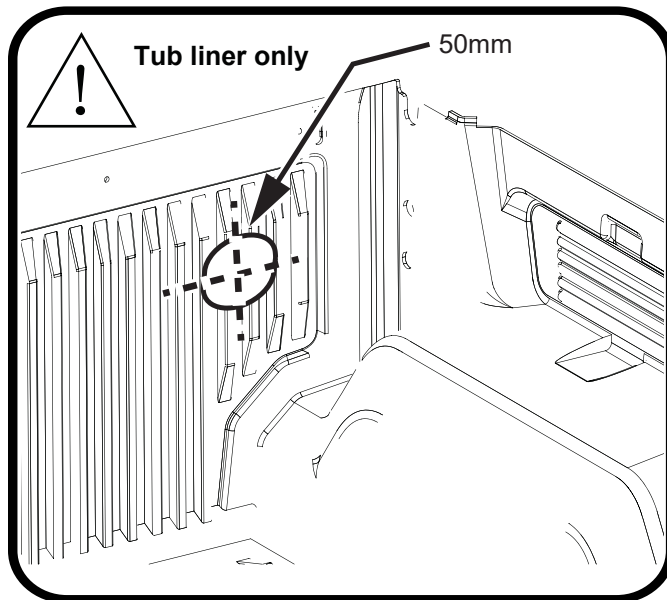
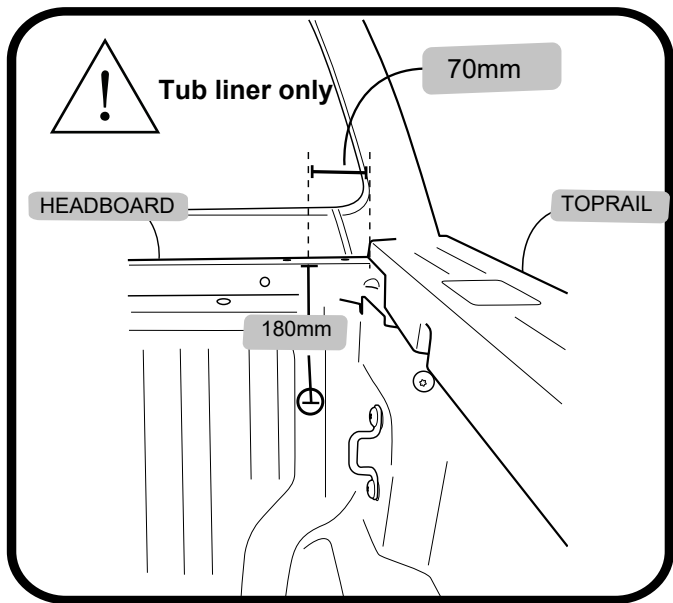

Now measure down from top of headboard 180mm & 70mm measuring from the side of the top rail. Repeat to the other side.

Now using a 30mm hole-saw drill through tub front panel, file away any sharp edges. Apply anti rust coating. Repeat to other side.

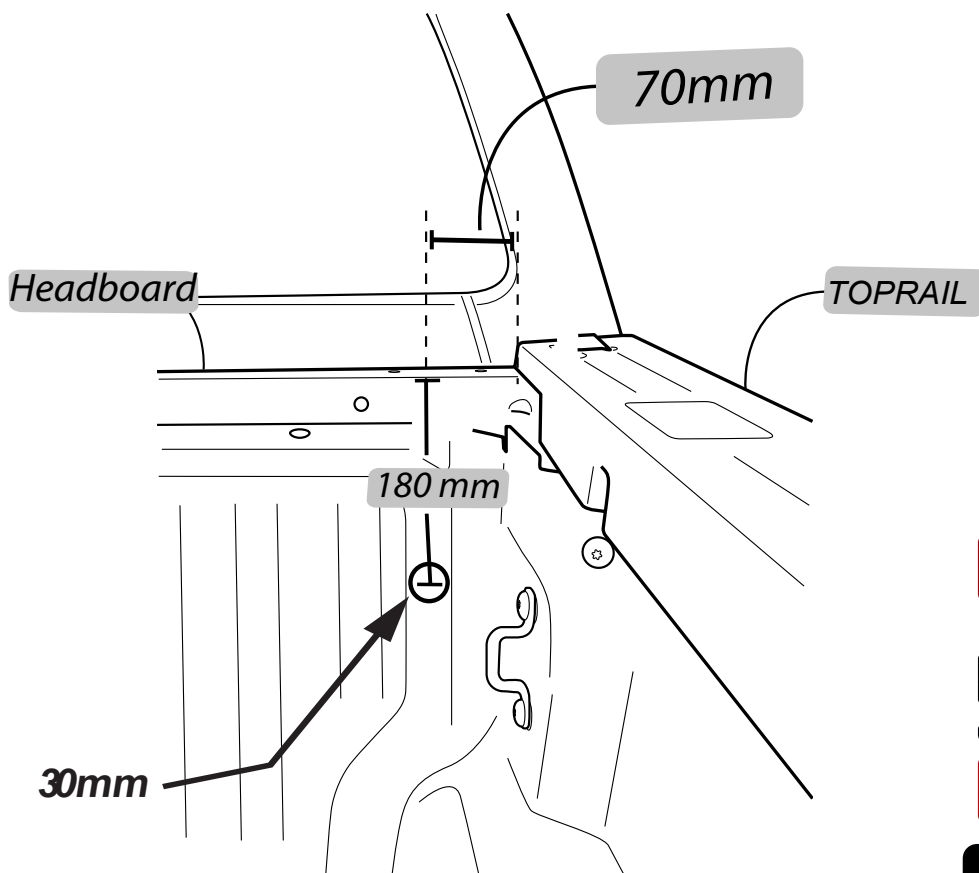
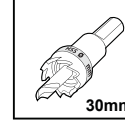
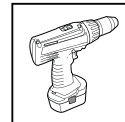
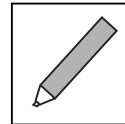
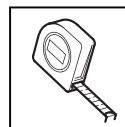

**ATTENTION:** Do not exceed 30mm hole.



Carefully unpack the box.

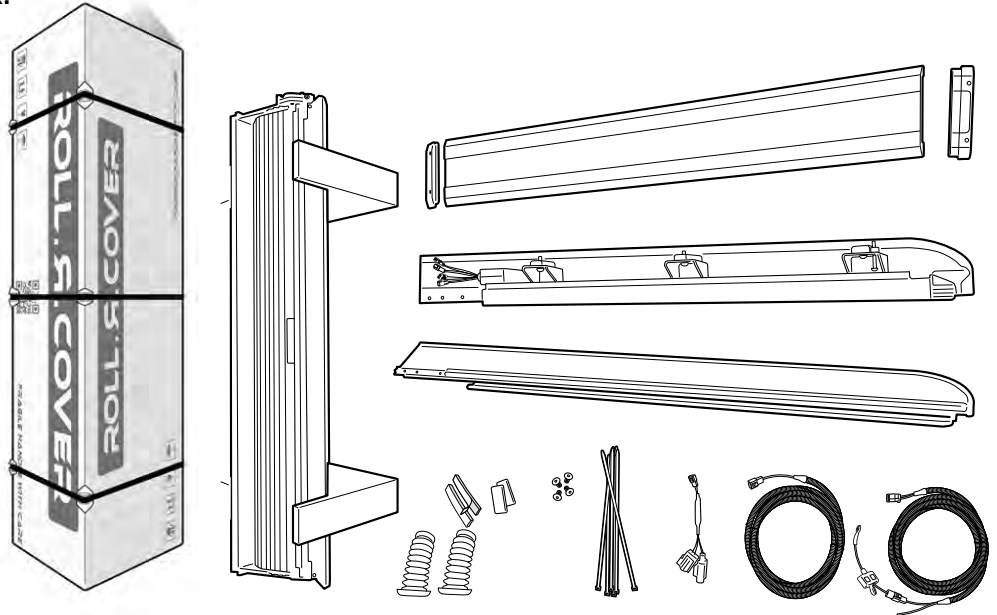

Install front drain pipes ( 55mm diameter end of hose) through pre-drilled holes on the front tub panel.



Note: With care push tube in. Taking care pull the tube back so it seals correctly against the front panel of the tub.

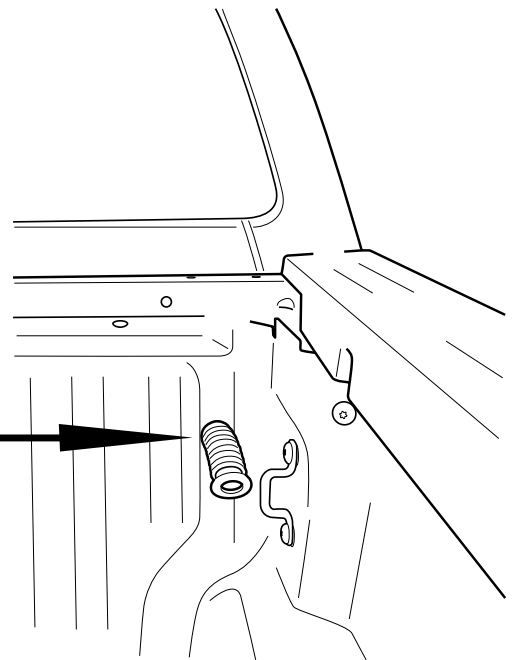
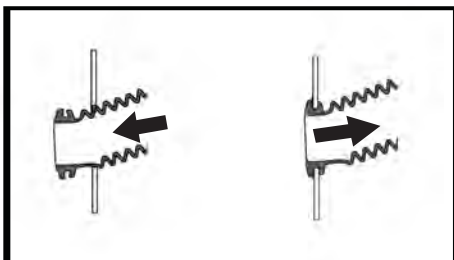

Measure down from top edge of the tub liner 55mm down, Now measure 70mm in towards the tailgate as indicated. Mark line as a guide, now trim that section of the tub liner and discard. Repeat to the other side.

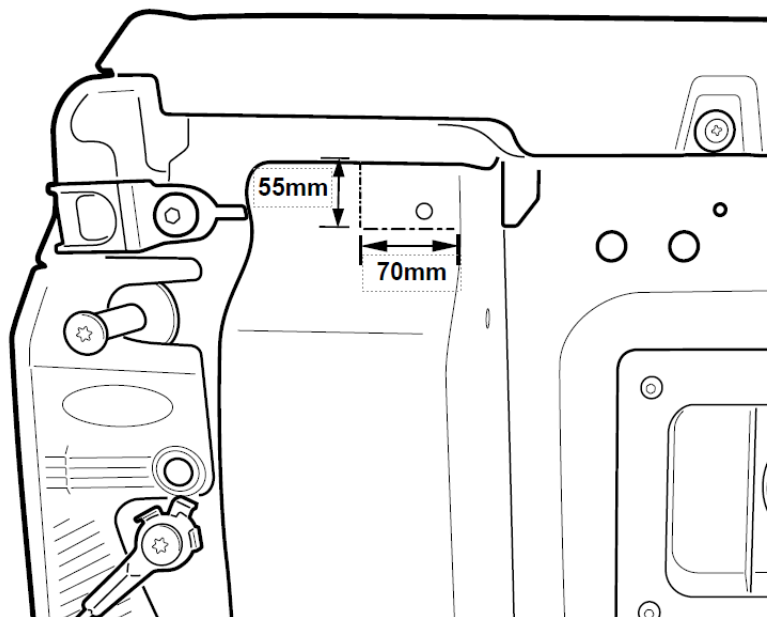

This step applies to vehicles equipped with a factory tub liner.

**NOTE:** Steps on this page are for vehicles fitted with a factory one piece tub liner only. If no tub liner is fitted skip to next page.

Measure 25mm towards the tailgate from the center of the indicated bolt. Measure down 110mm from the edge of the plastic trim as directed and make a mark.

Use a 15mm hole-saw to drill through the tub liner only, clean edges. Repeat the same steps on the other side.

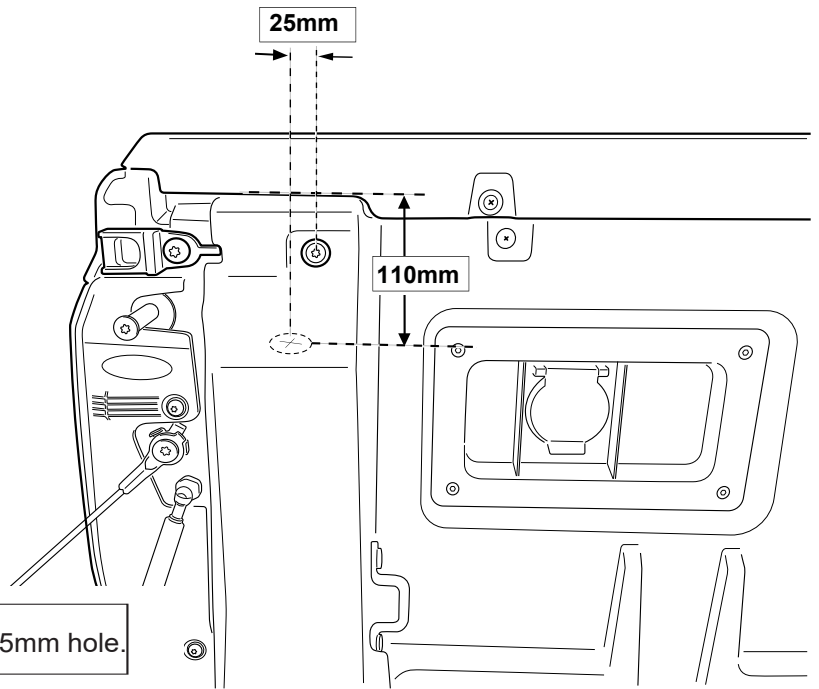

**! ATTENTION:** Do not exceed 15mm hole.

- a** In the specified orientation insert the rear drainage pipe into the previously drilled hole.
- b** Leaving 150mm of the pipe hanging out.
- c** Check the tub liner cavity to ensure there are no obstructions to the drainage pipe. Repeat to the other side.  
Re-fit the tail lights.

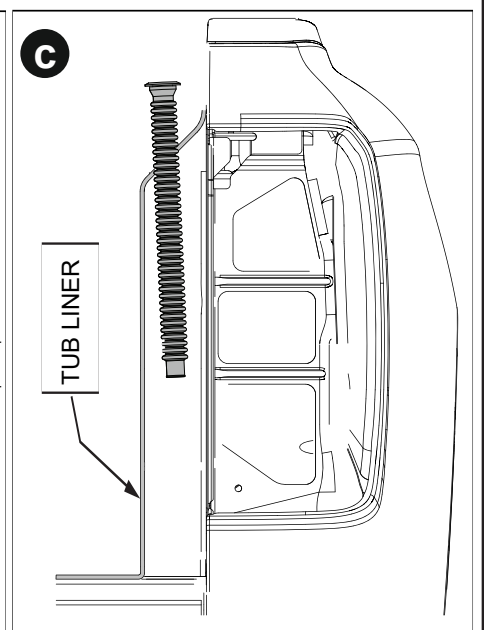
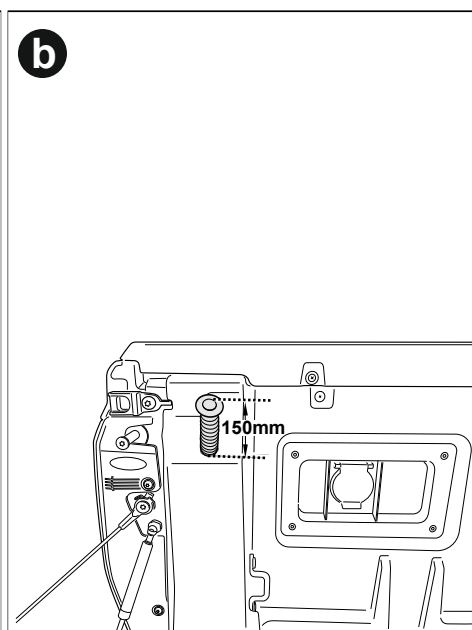
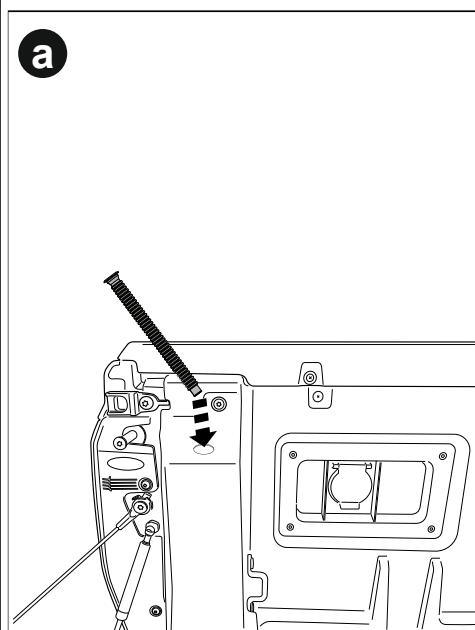

Remove and retain tail lights.

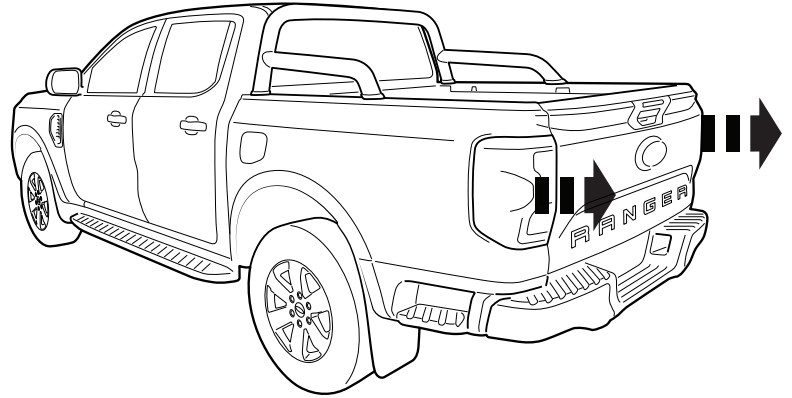

Measure 35mm towards the tailgate from the center of the indicated factory M6 thread. Measure down 75mm from the edge of the plastic trim as directed and make a mark.

Use a 15mm hole-saw to drill through the tub pillar, and file away any sharp edges. Apply an anti-rust coating. Repeat the same steps on the other side.

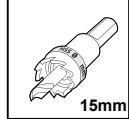
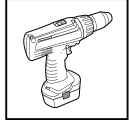
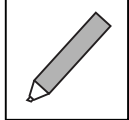
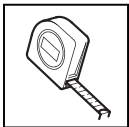

**ATTENTION:** Do not exceed 15mm hole.

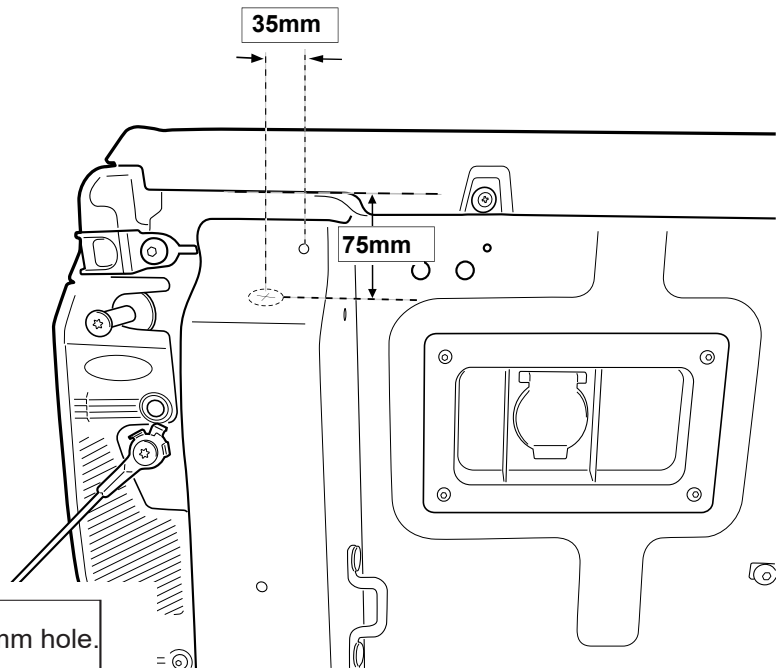

- a** In the specified orientation insert the rear drainage pipe into the previously drilled hole.
  - b** Leaving 150mm of the pipe hanging out.
  - c** Check the tail light cavity to ensure there are no obstructions to the drainage pipe. Repeat to the other side.
- Re-fit the tail lights.

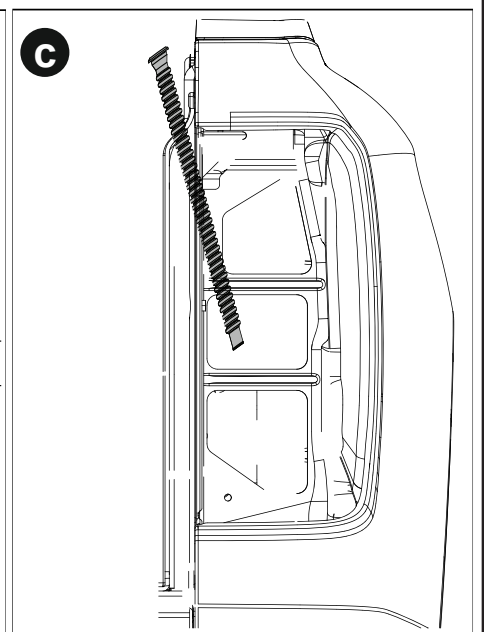
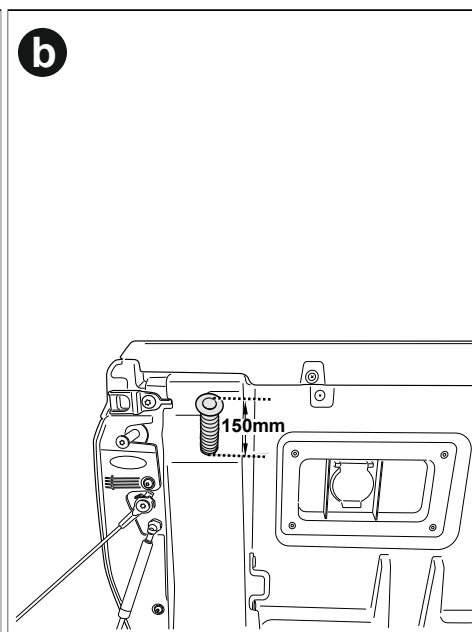
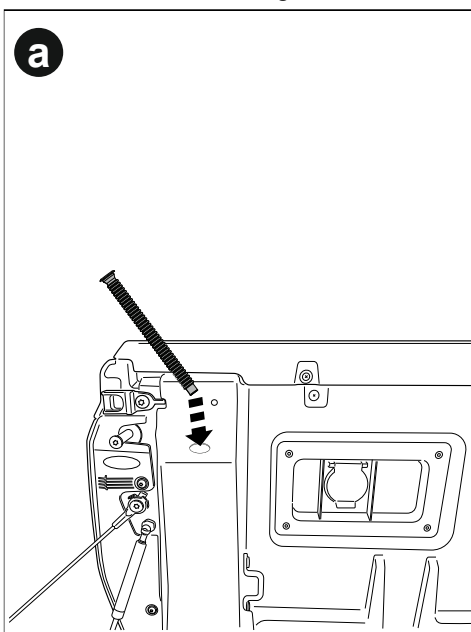

**Sealing factory gaps on the bed. It is recommended to use black sealant.**

Apply an adequate amount of sealant to the areas indicated, then smooth sealant out. Clean any excess sealant. Repeat to the other side.

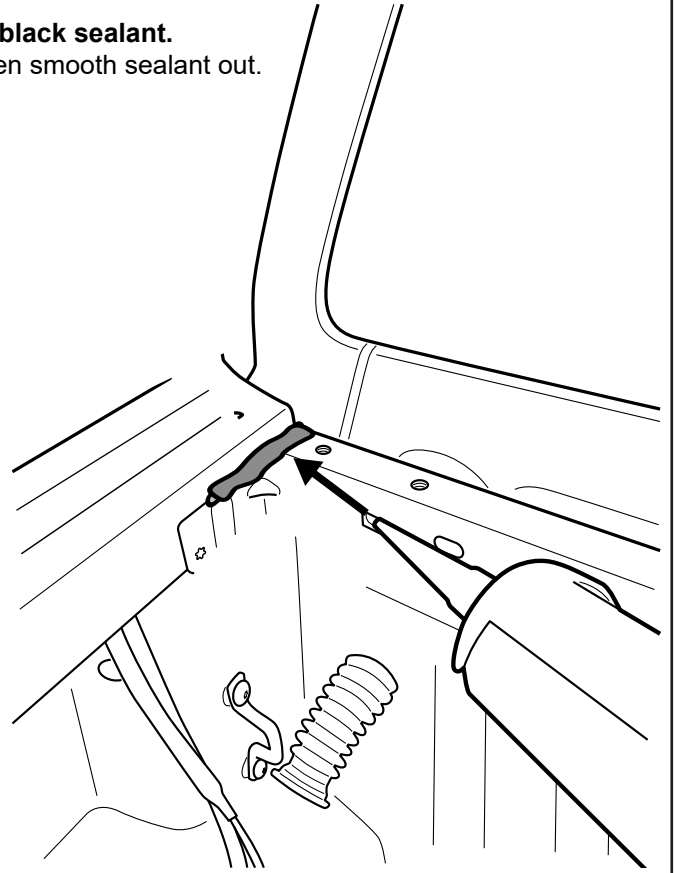

Place front bar assembly (NGR-FBA) over the head board as indicated.

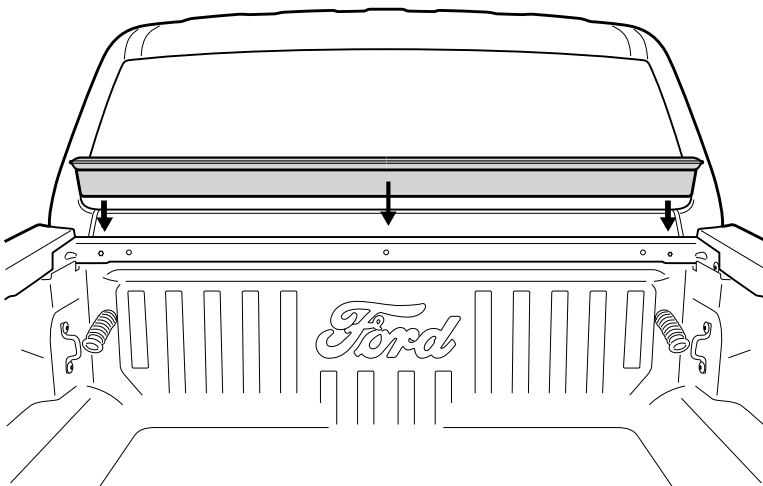
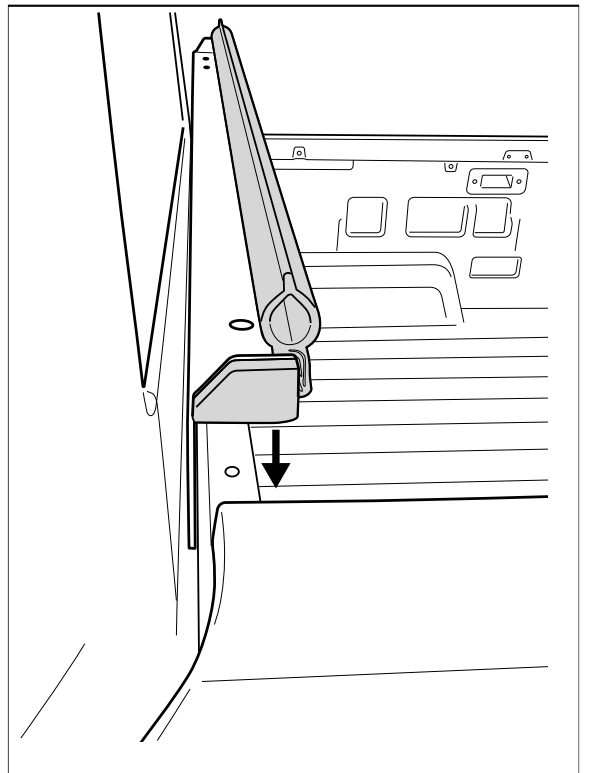

Firmly push down on the FBA bar so it sits centered and flush to the headboard.

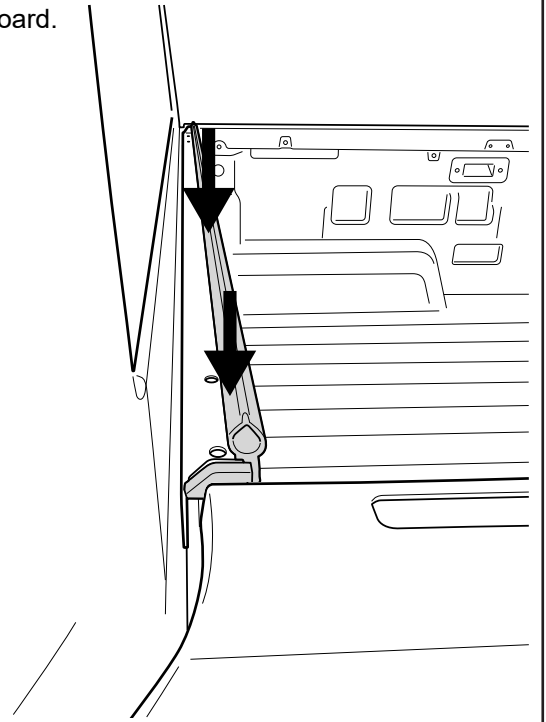

Using black M8 x 25mm bolt, followed by black M8 washer and black M8 rubber washer feed through the indicated holes of the FBA bar and fasten to the tubs headboard.

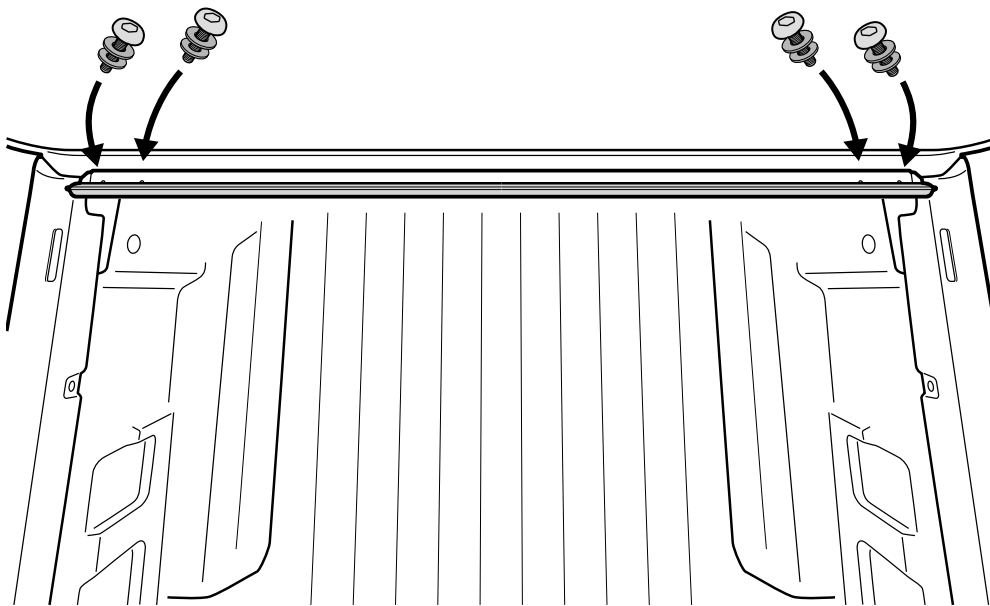

Fasten the bolts to 6NM torque.

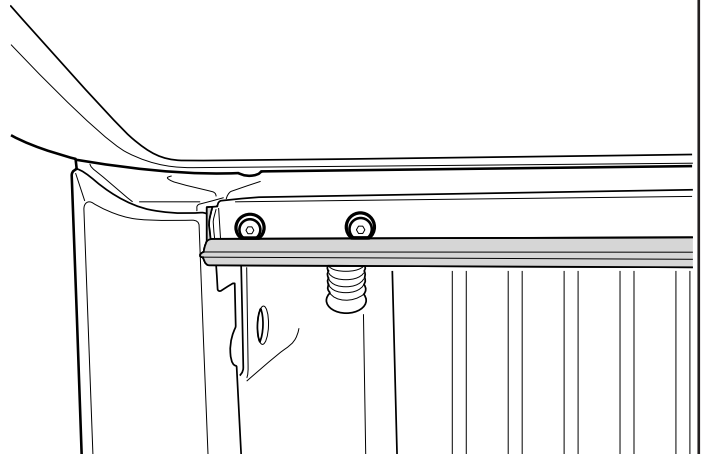



**Sealing all gaps between FBA bar and the tub and its fittings.**

It is recommended to use black sealant. Apply an adequate amount of sealant to the areas indicated, then smooth sealant out. Clean any excess sealant. Repeat to the other side.

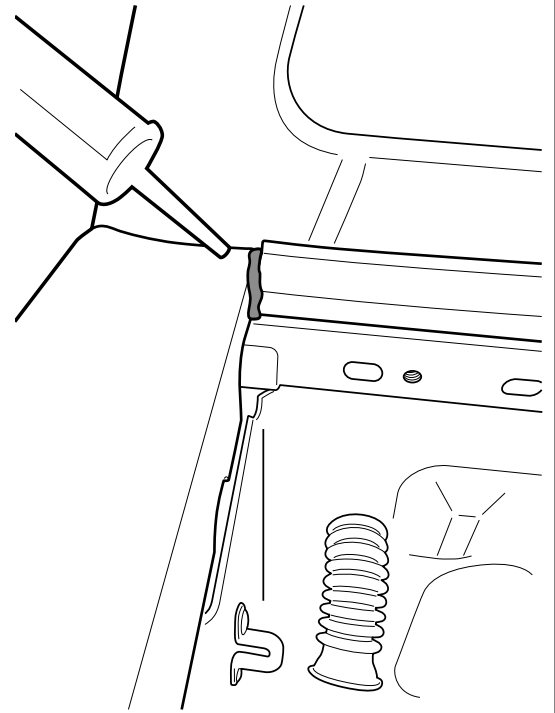

**Ensure all openings in the rubber pinch weld fitted to the FBA bar, as well as the tub and its connections, are completely sealed**

It is recommended to use black sealant. Apply an adequate amount of sealant to the areas indicated, then smooth sealant out. Clean any excess sealant. Repeat to the other side.

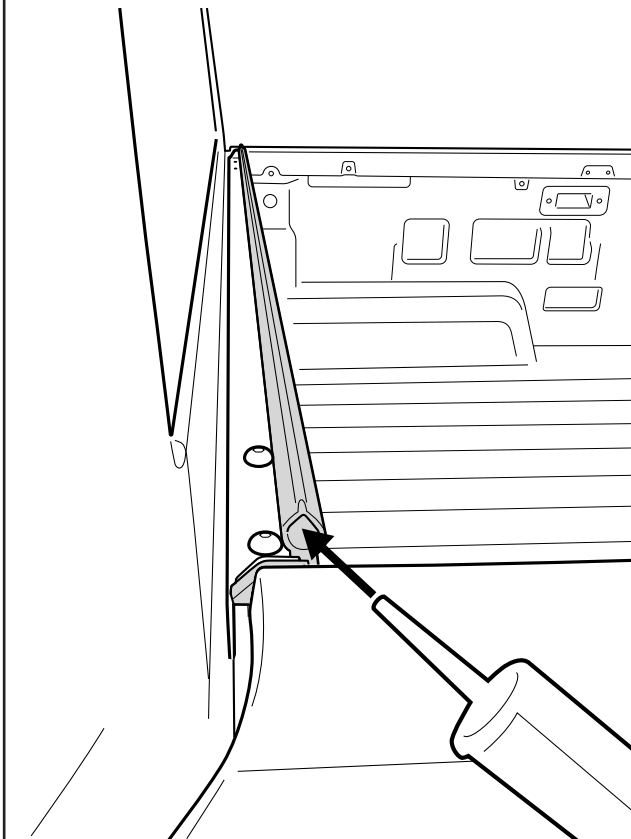
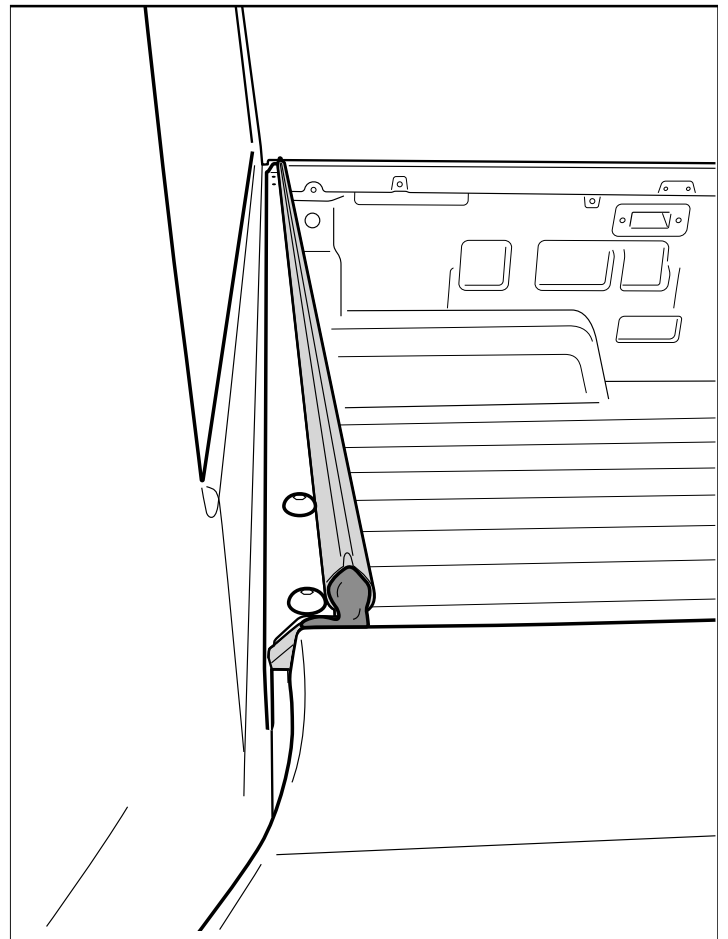

Align RHS brace bracket to the indicated threads of the tub.

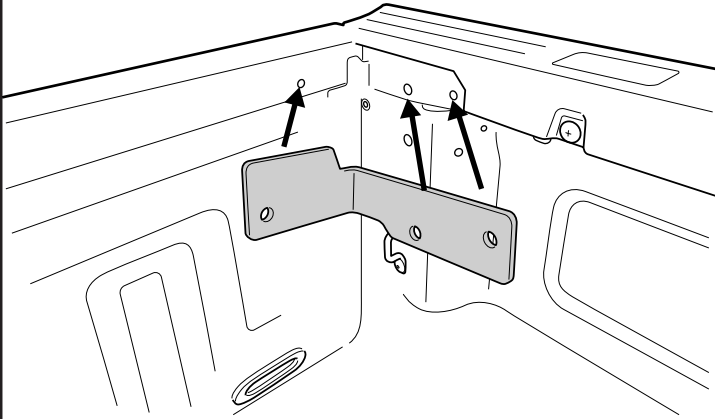

Fasten loosely into position using retained factory bolts.  
If factory bolts were not provided use supplied black M8 x 30mm in the kit.

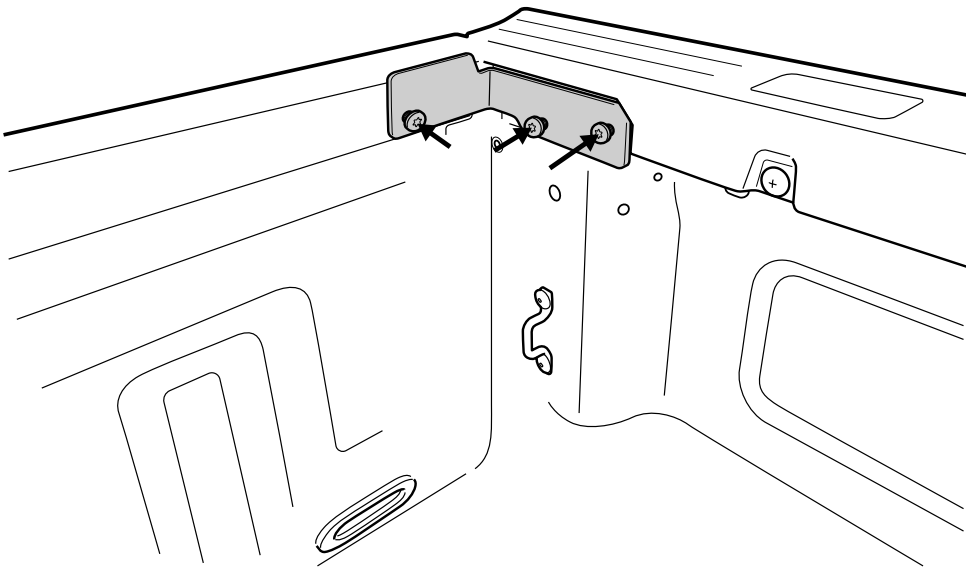

1. Fasten location **a** to 20Nm torque.
2. Fasten location **b** to 20Nm torque.

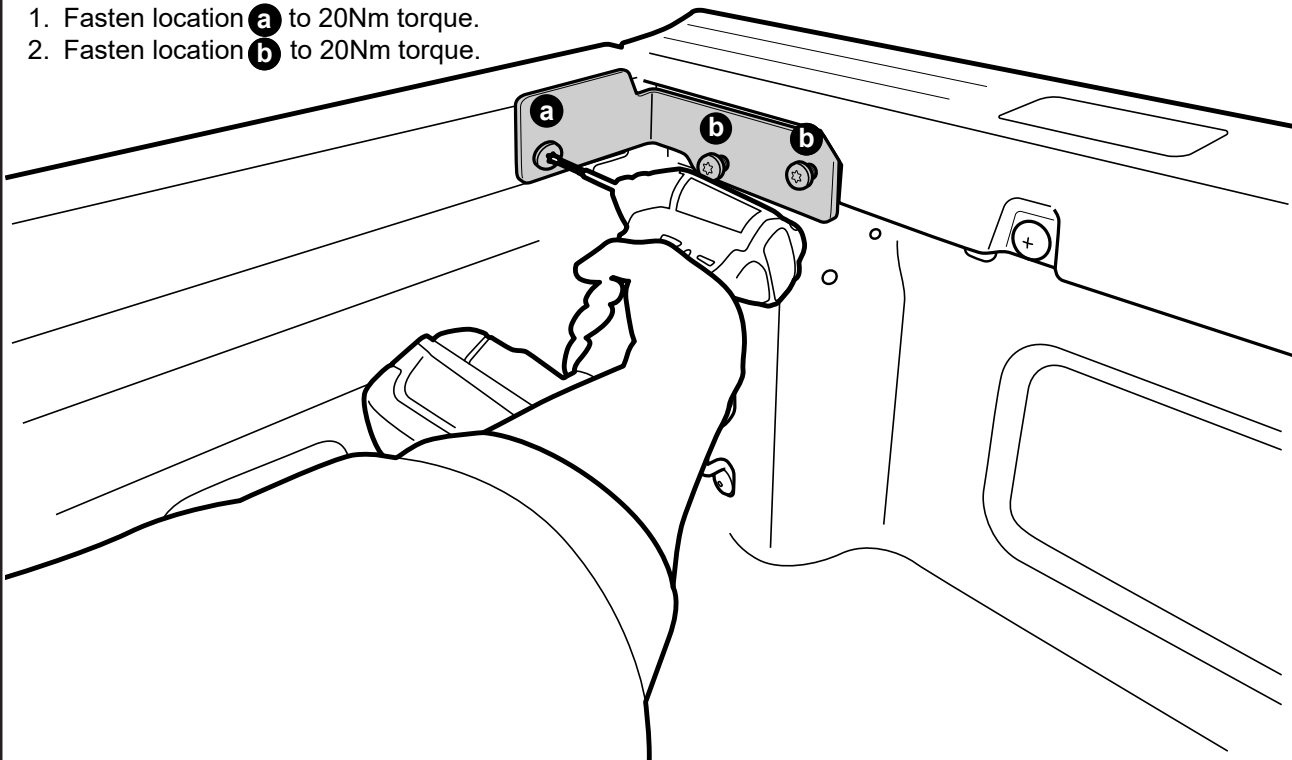

**Sealing any gaps on the bed, FBA bar and the brace bracket . It is recommended to use black sealant.**

Apply an adequate amount of sealant to the areas indicated, then smooth sealant out.

Clean any excess sealant. Repeat to the other side.

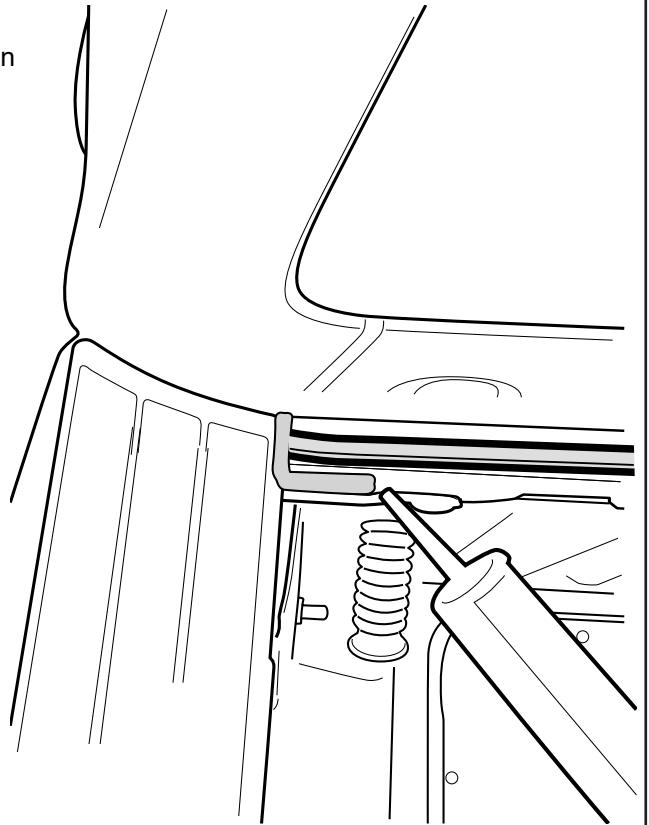

**Sealing any gaps on the bed, FBA bar and tub trims. It is recommended to use black sealant.**

Apply an adequate amount of sealant to the areas indicated, then smooth sealant out.

Clean any excess sealant. Repeat to the other side.

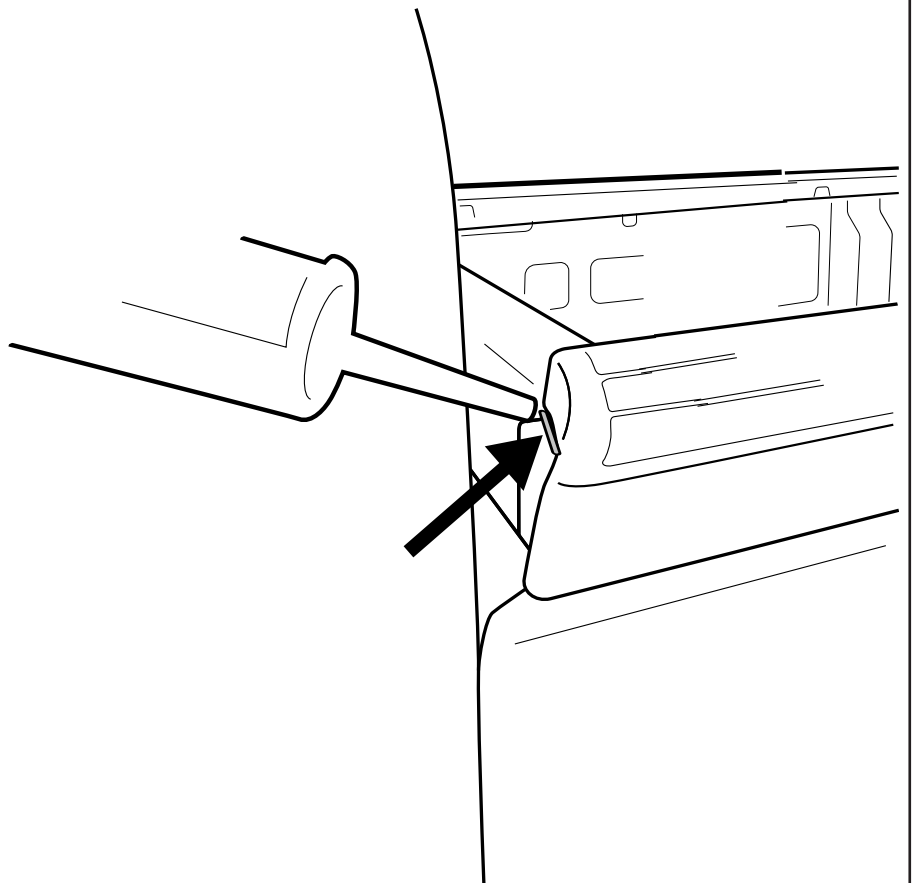

Disconnect fuse patch from battery loom S2.75.

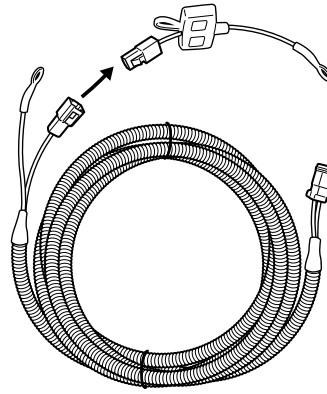

### Wiring Harness steps

**1** Feed Battery Loom S2.75 through the cavity

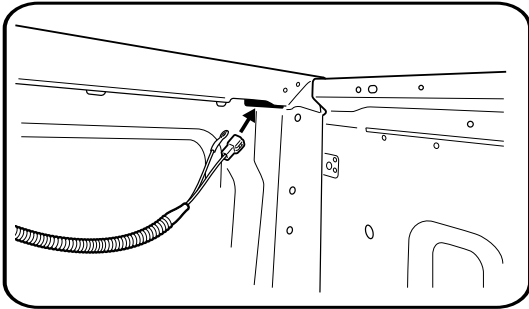

**3**

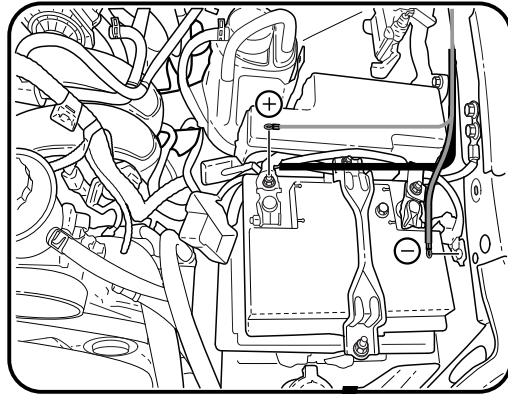

**2**

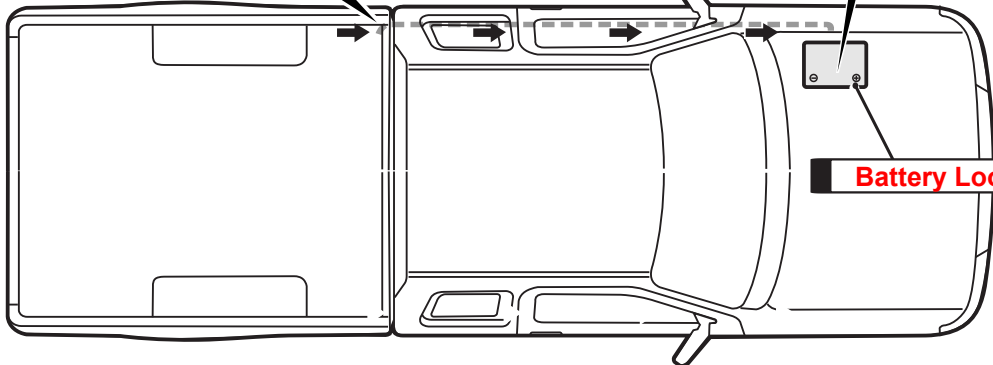

Run the wiring from the front corner cavity ( leaving 200mm in the tub) to the battery over the chassis rail. Making sure to keep away from hot obstructions and cable tie every 400mm. Reconnect fuse patch to battery loom S2.75, now attach fuse patch to positive of battery and earth to the body of the Ute.

Feed CL-Short-Loom through the cavity.

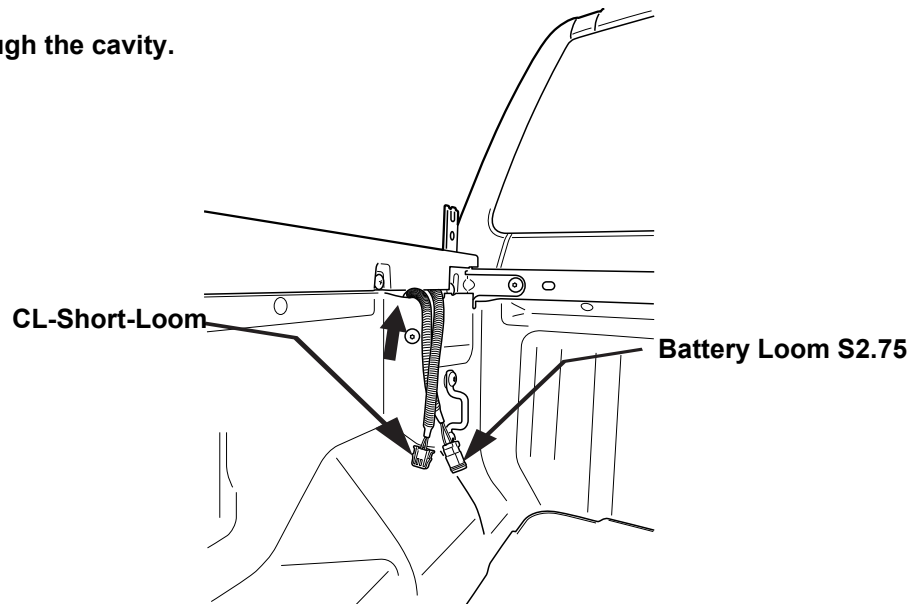

Remove required clips to gain access to passenger side rear wheel arch inner.

RAPTOR

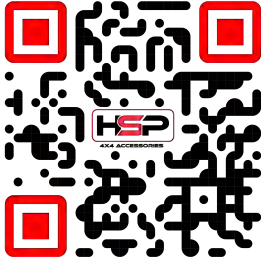

VISUAL TIP

RANGER

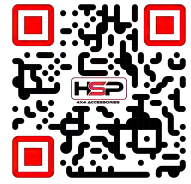

VISUAL TIP

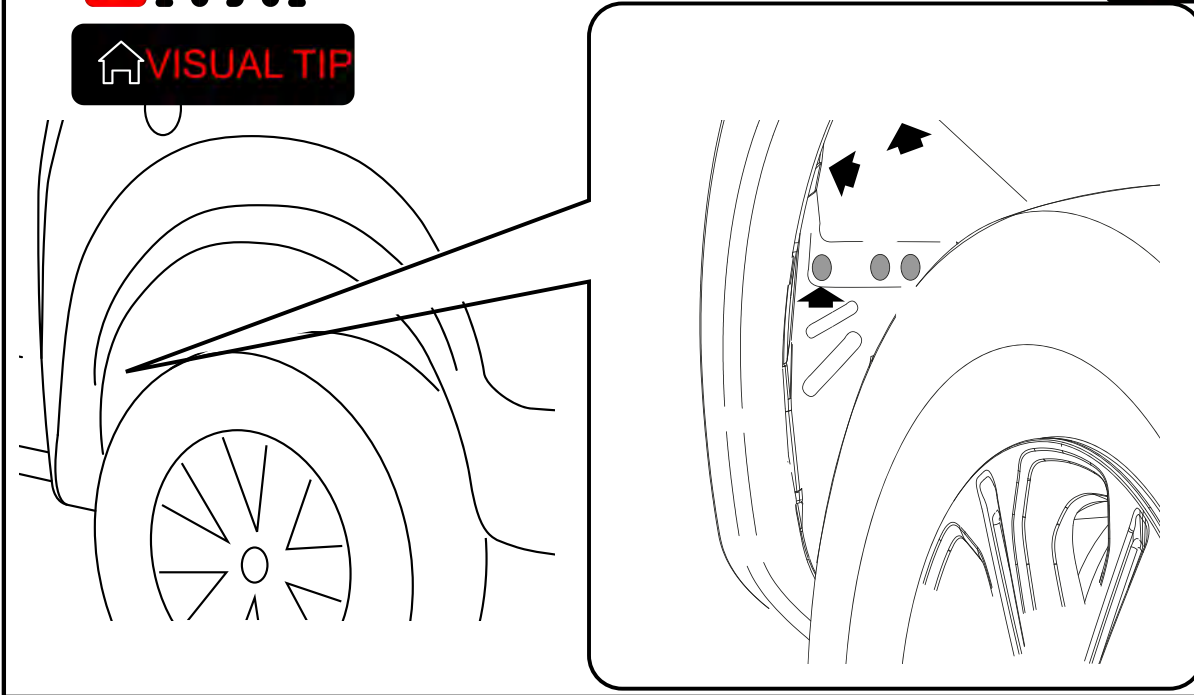

**NOTE:** image used is for illustration purpose only.

1. Disconnect the fuel flap actuator connector ( 1 ).
2. Patch the NGR-Patch to fuel cap actuator connector and actuator connector.
3. Use one zip tie to secure the harness to the existing harness.
4. Connect CL-Short-Loom to NGR-Patch. Zip tie any loose loom within wheel arch.

FUEL CAP ACTUATOR  
CONNECTOR

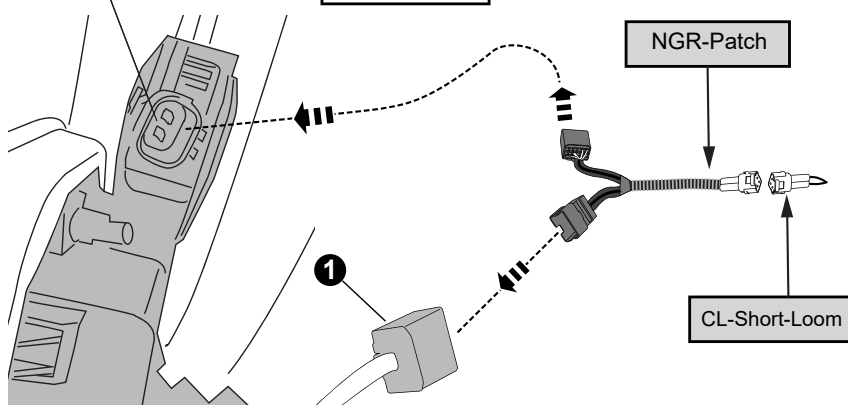
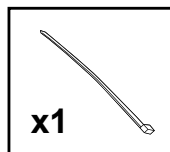

**NOTE:** image used is for illustration purpose only.



keep the cannister in the foam blocks from the packaging for assembly.

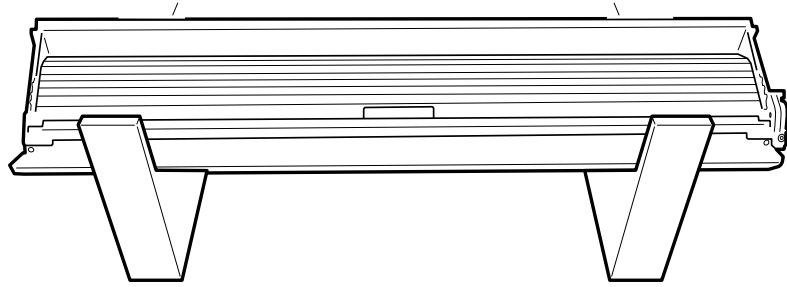

With assistance turn the canister on its back on the foam blocks.

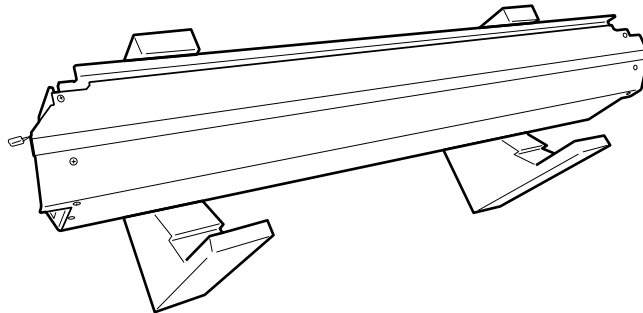

Disengage motor from the axle by unfastening the 3 Screws as indicated. Retain all parts.

Remove and retain the 3 screw from the canister as indicated.

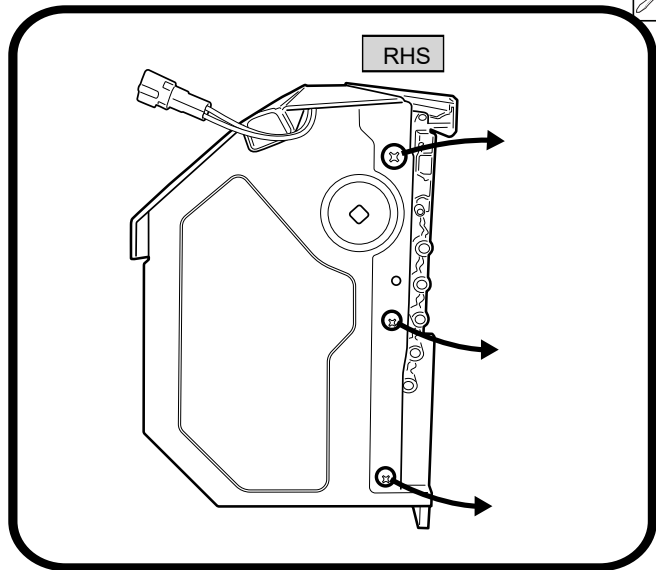
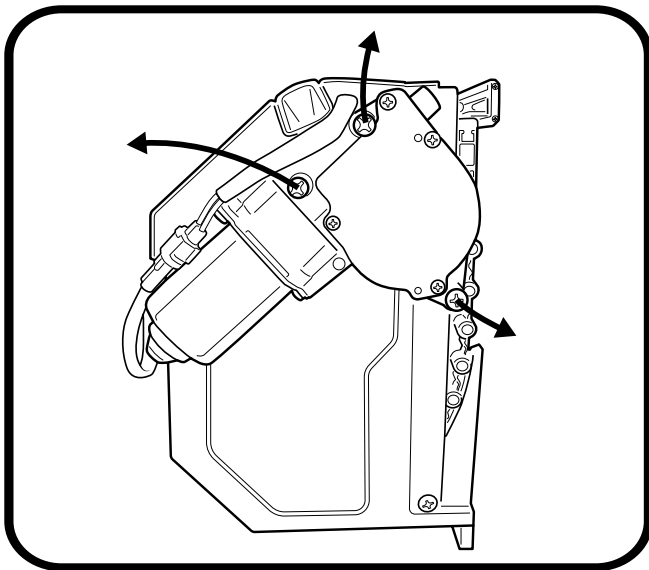

Now on the other side, remove and retain the 4 screws from the canister as indicated.

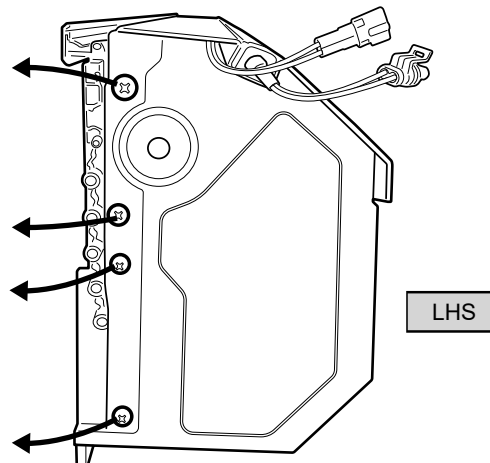
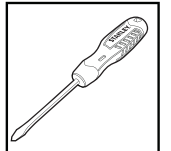



**Important Note:** Ensure that the Z seal within the track is positioned over the curtain and not folded inward. **WARRANTY** voided if assembled incorrectly.

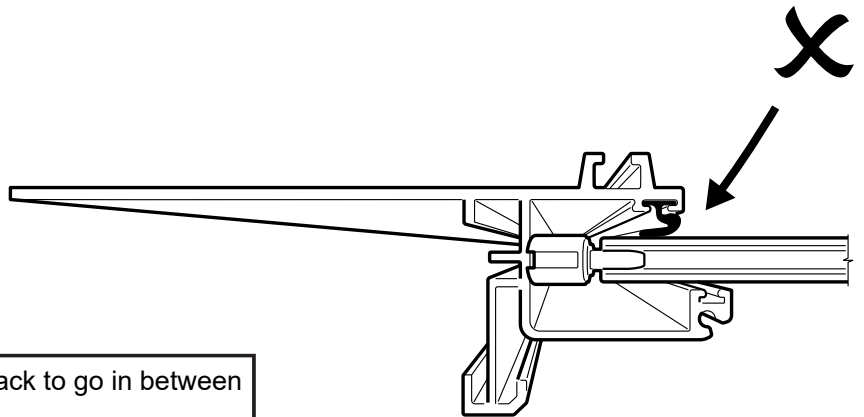
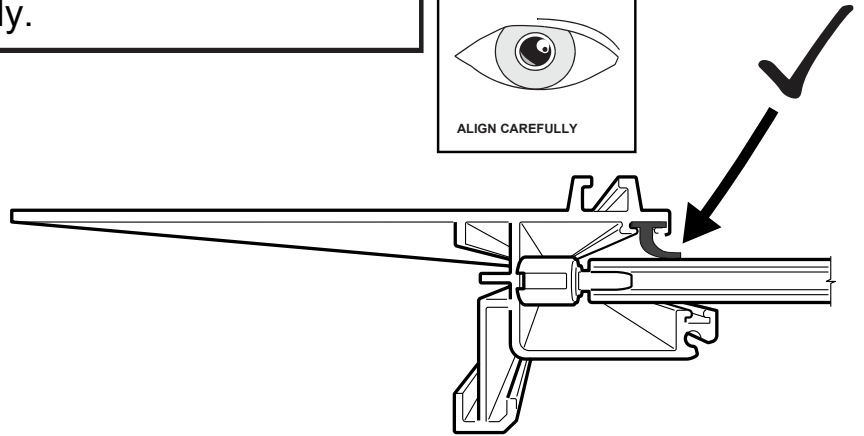
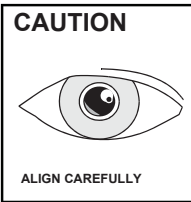

Align side rail to side of canister, guide the track to go in between the curtain end rubber stop.

NOTE: LHS side rail to be assembled first.

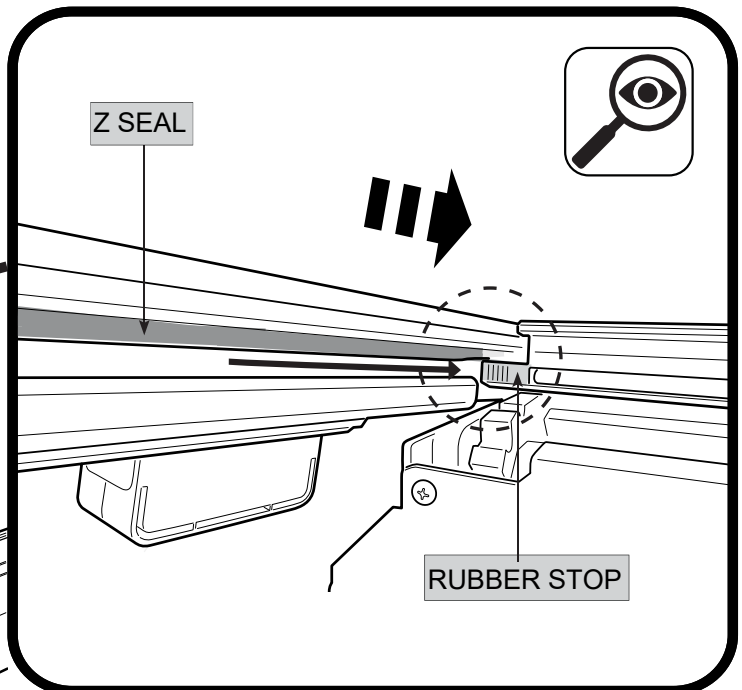
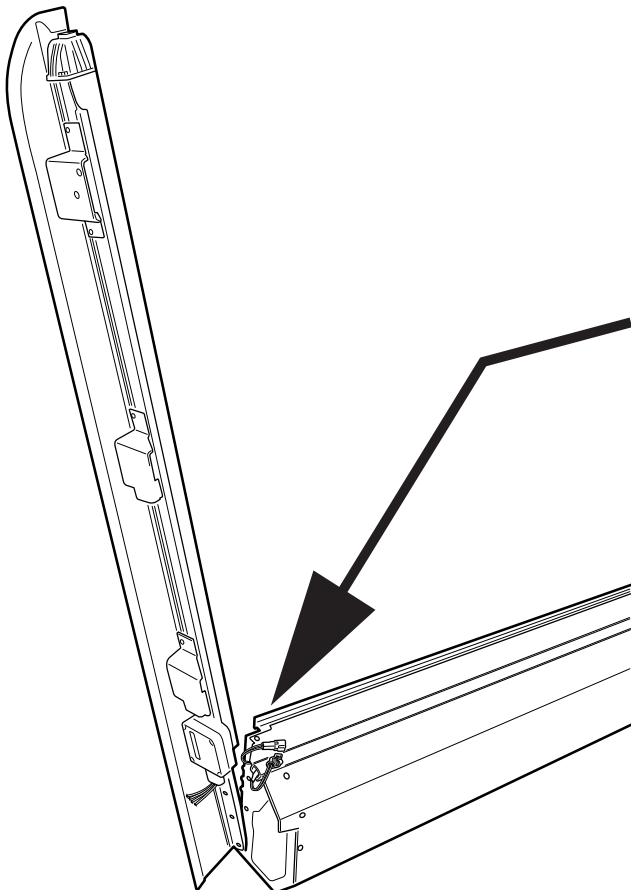

1. Using the retained screws, spring washer and washer, Loosely fasten the side rail to the location indicated.
2. Side rail edge must compress and meet with the canister profile as indicated below.
3. Fasten all screws tight.

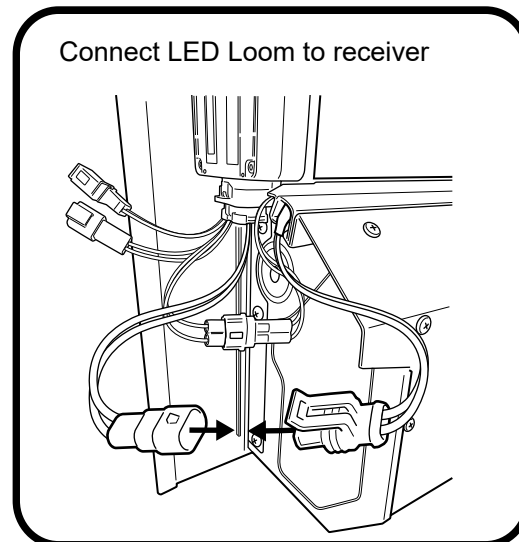
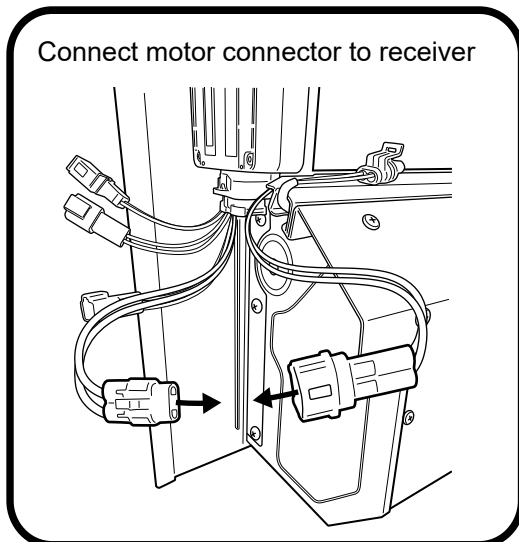
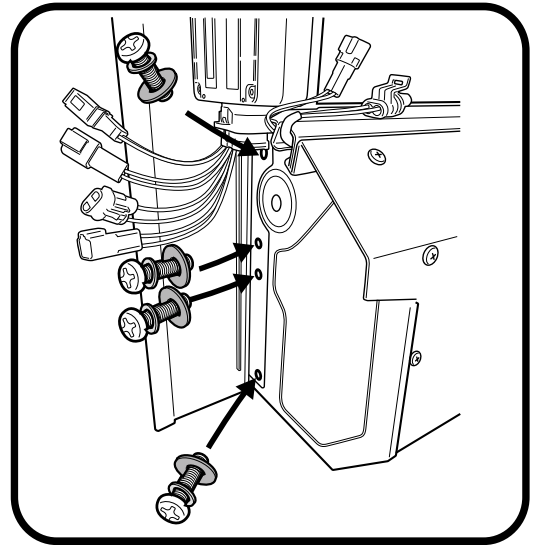
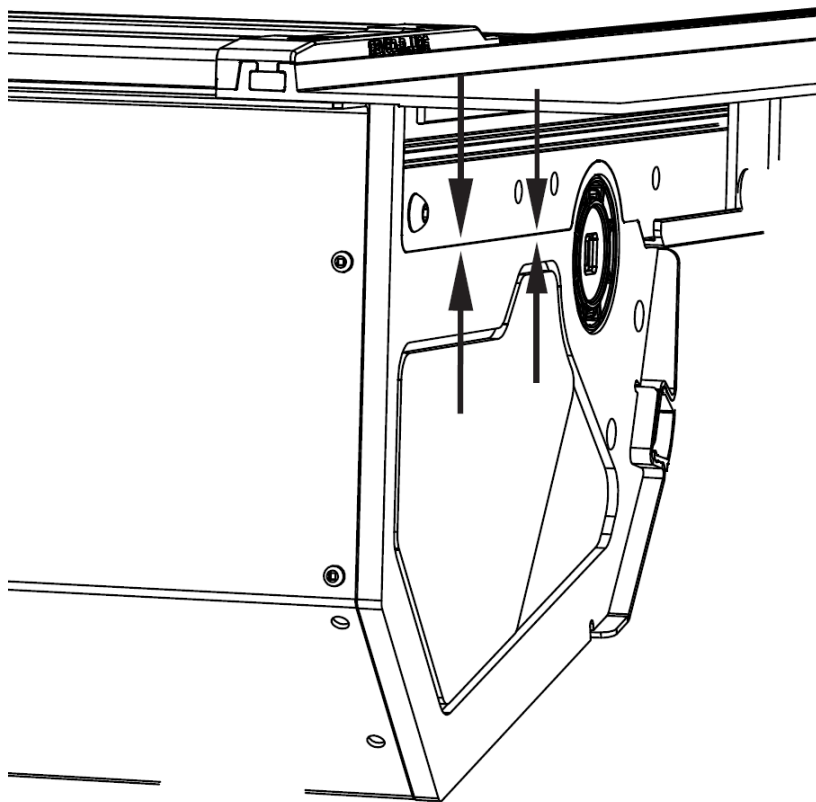
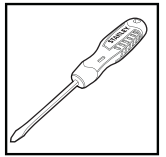



**Important Note:** Ensure that the Z seal within the track is positioned over the curtain and not folded inward. **WARRANTY** voided if assembled incorrectly.

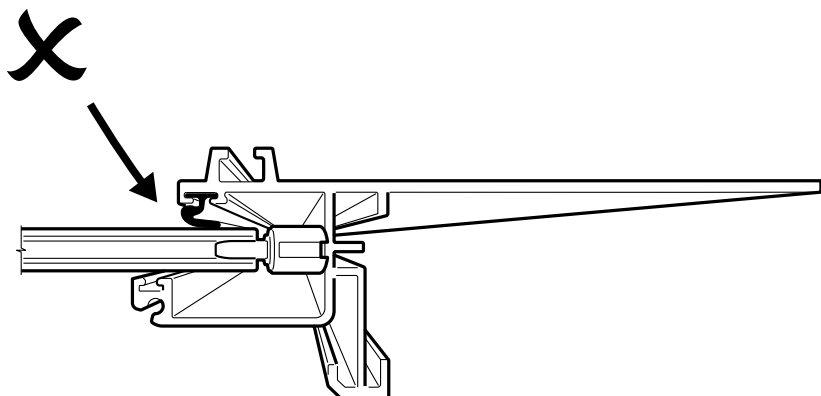
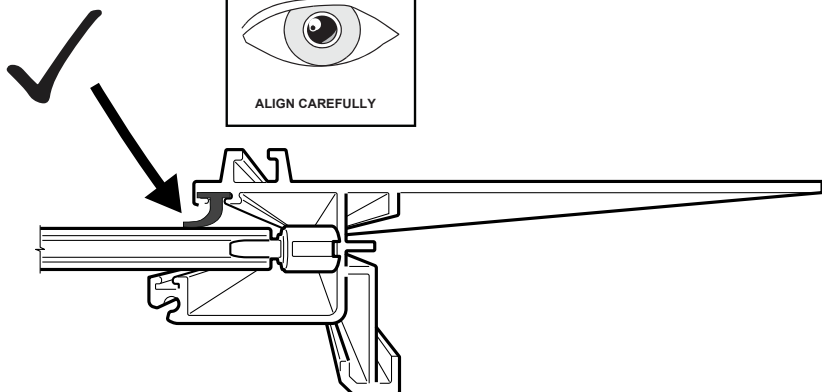
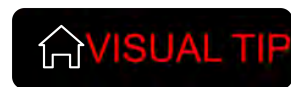

Align side rail to side of canister, guide the track to go in between the curtain end rubber stop.

NOTE: LHS side rail to be assembled first.

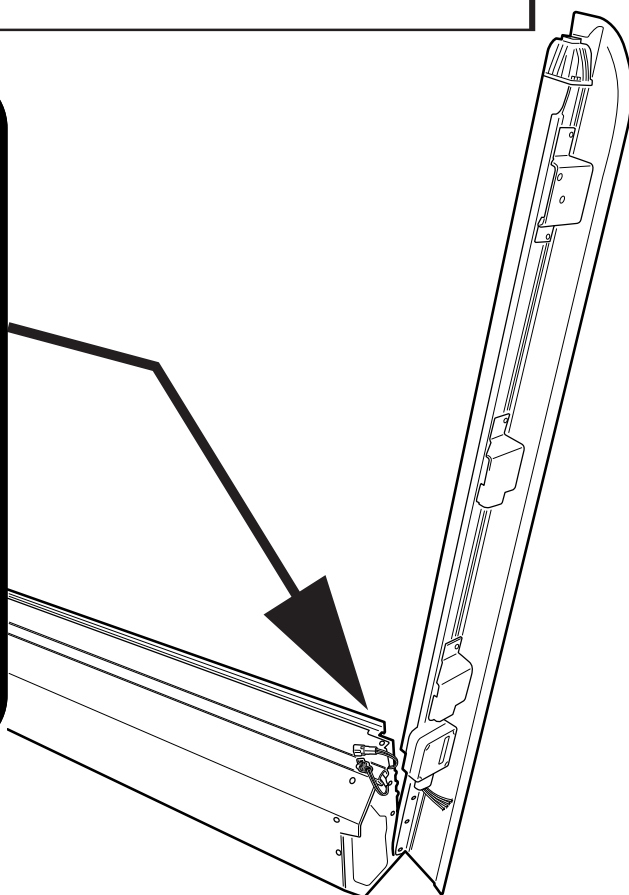
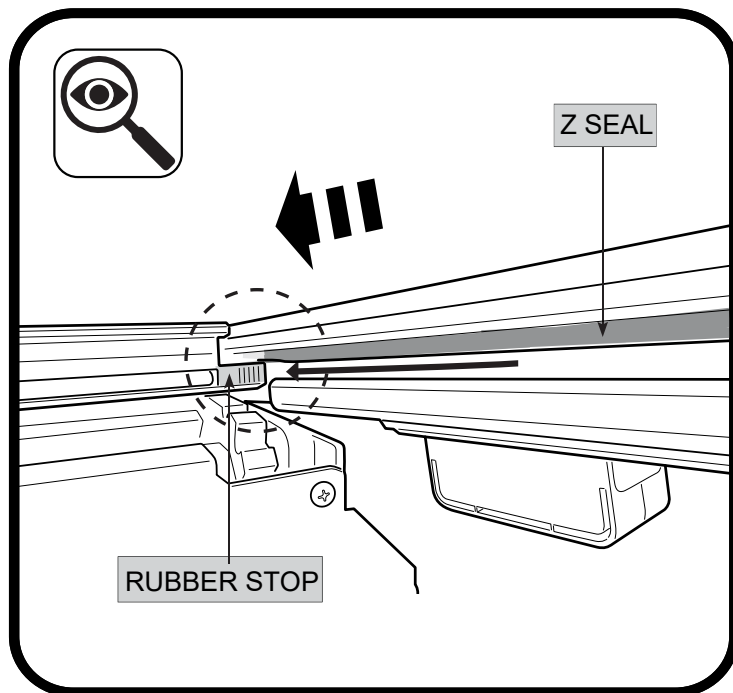

1. Using the retained screws, spring washer and washer, Loosely fasten the side rail to the location indicated.
2. Side rail edge must compress and meet with the canister profile as indicated below.
3. Fasten all screws tight.

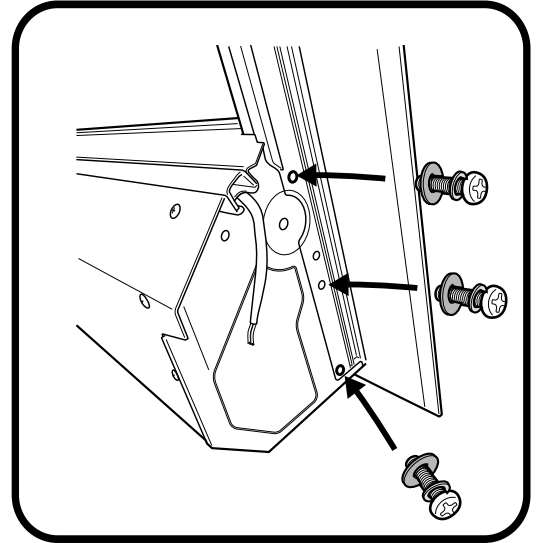
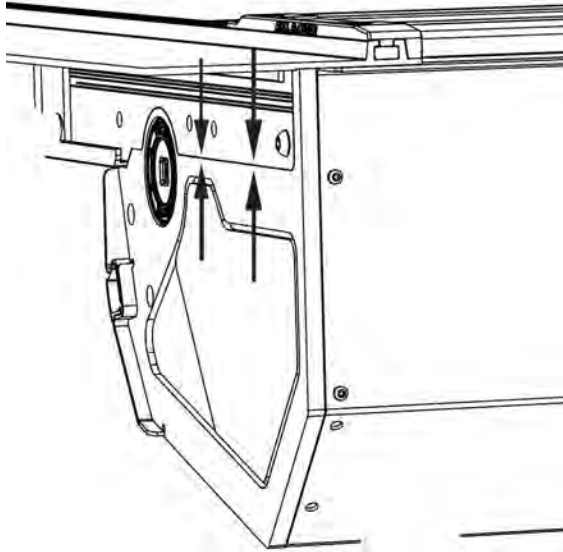
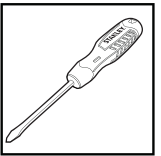

Feed M6 bolt through spring washer, motor and rubber bush.

**NOTE:** Rubber bush orientation has to be as per image. ( side with text on rubber, to face the motor).

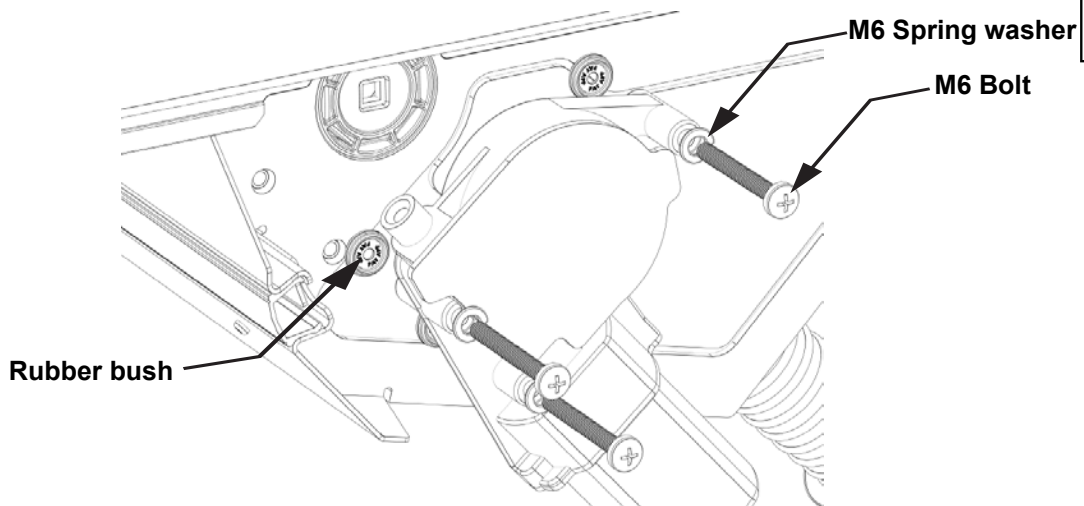
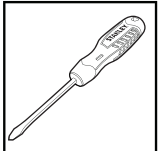

Align & insert motor shaft to axle.

**NOTE:** Pull / push curtain for axle to rotate.

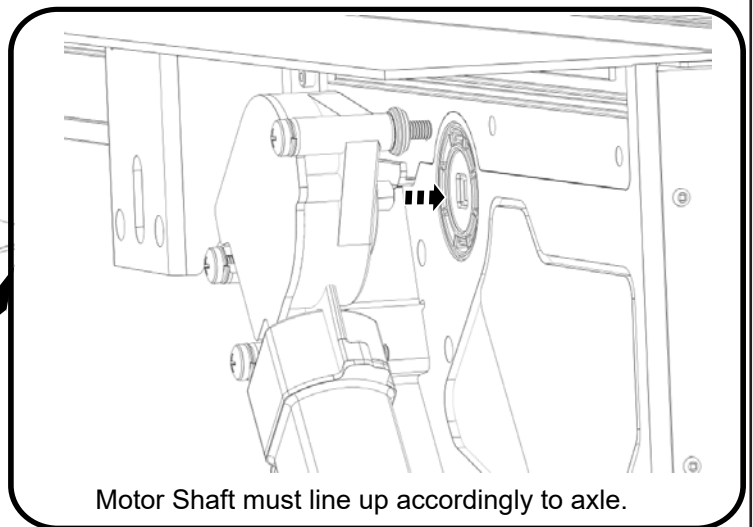
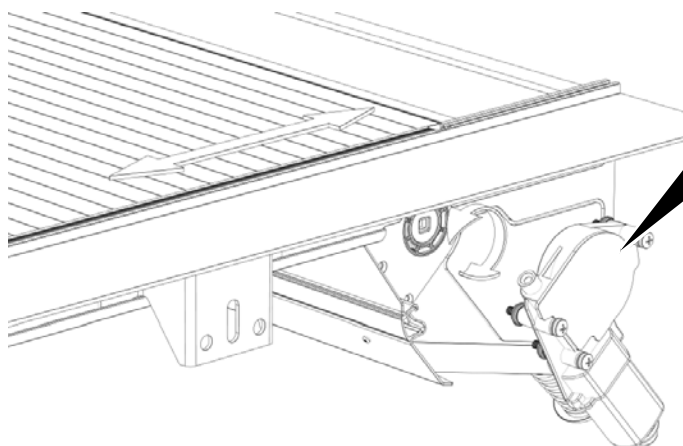

Motor Shaft must line up accordingly to axle.



Fasten all 3 screws to 2nm torque. Over tensioning will cause operating issue's.

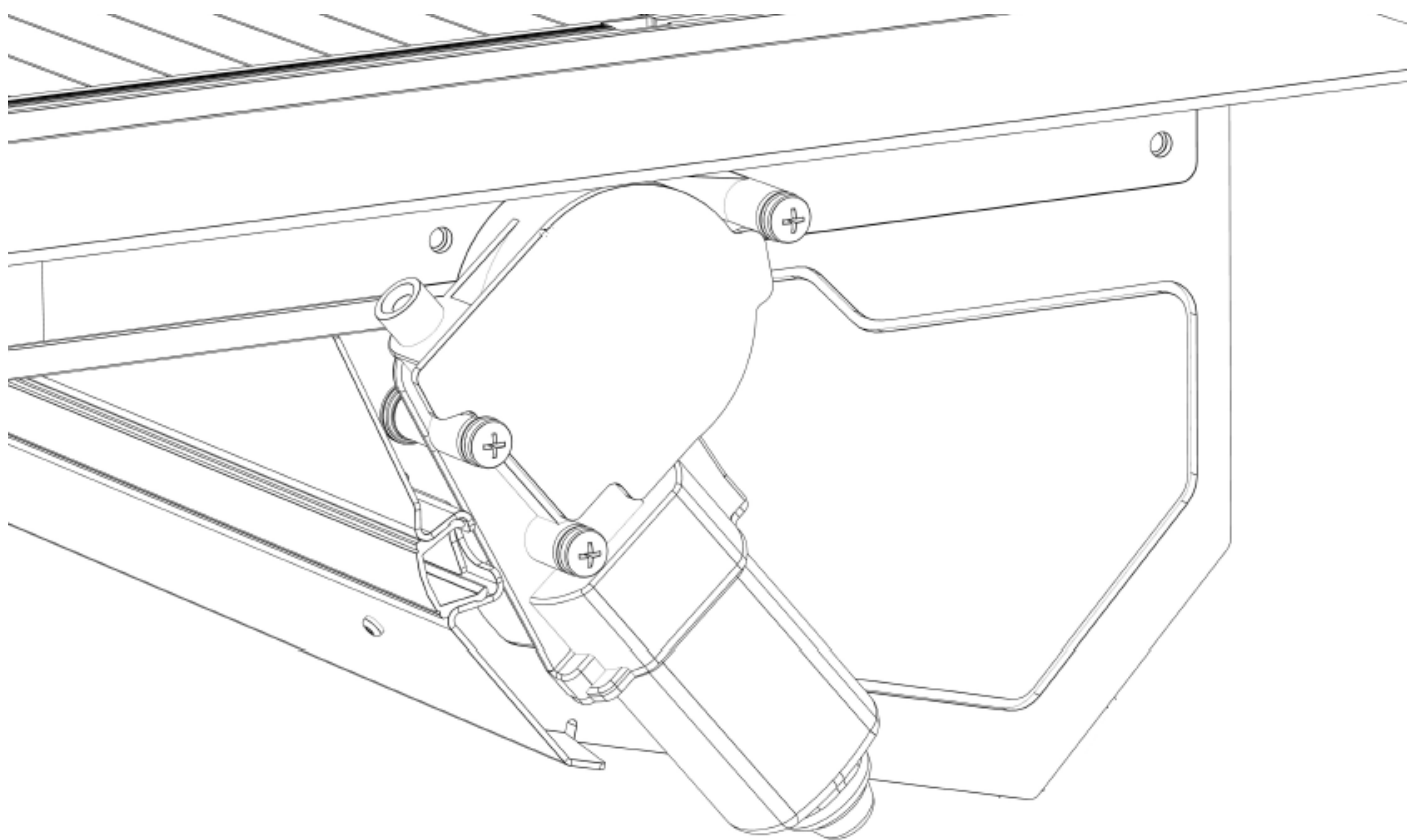
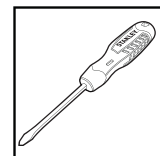

**Motor is to sit level.**

Any obstructions between motor and canister may cause operating issues.

Carefully bring down the assembled unit.

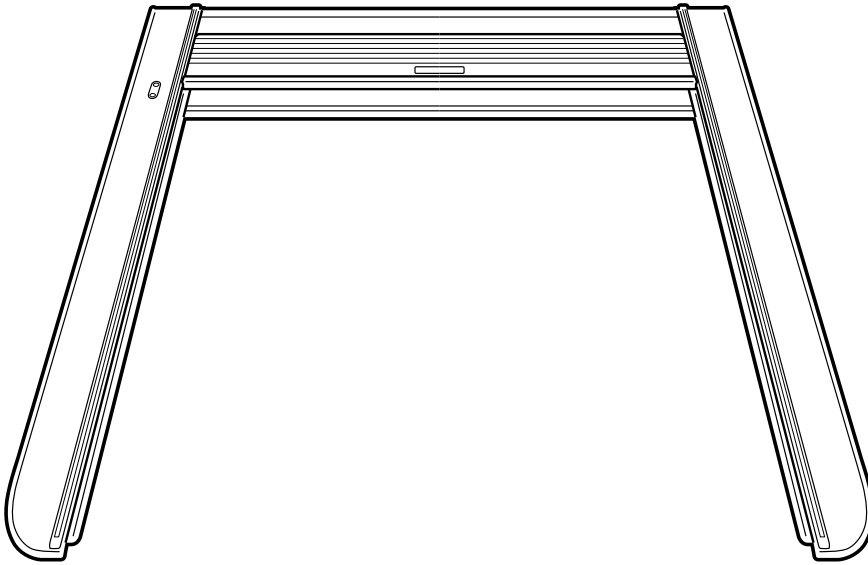

Insert side end caps to the top cover.

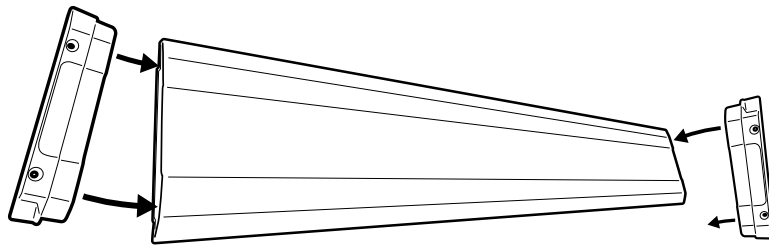

Place & Align top cover over the canister and side rails.

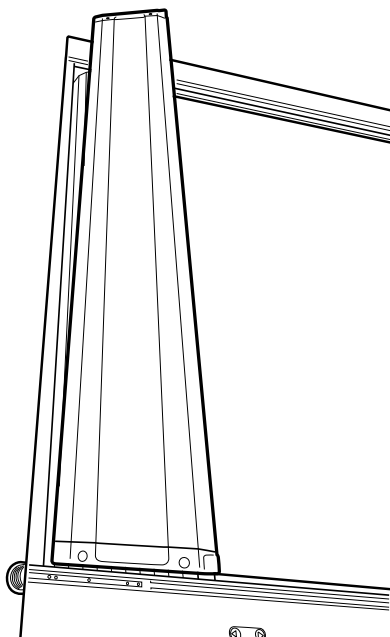

Using countersunk screws provided, line up end cap holes to the threads on the side rail. Fasten to 3nm torque. Repeat to the other side.

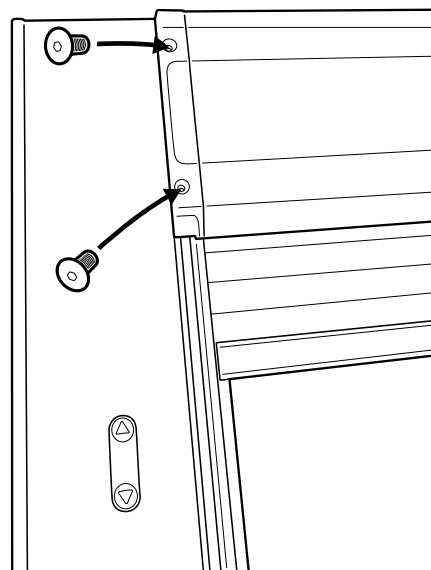

Position the LHFC (front left cup) onto the side rail as directed.

- a** Match the circular indentation with the hole on the side rail.
- v** Insert the provided M6x25mm countersunk bolt through the indicated side rail hole, passing through an M8 flat washer.
- w** While holding the cup securely, carefully guide the bolt's thread through the indicated circular indentation.
- x** Completed view.

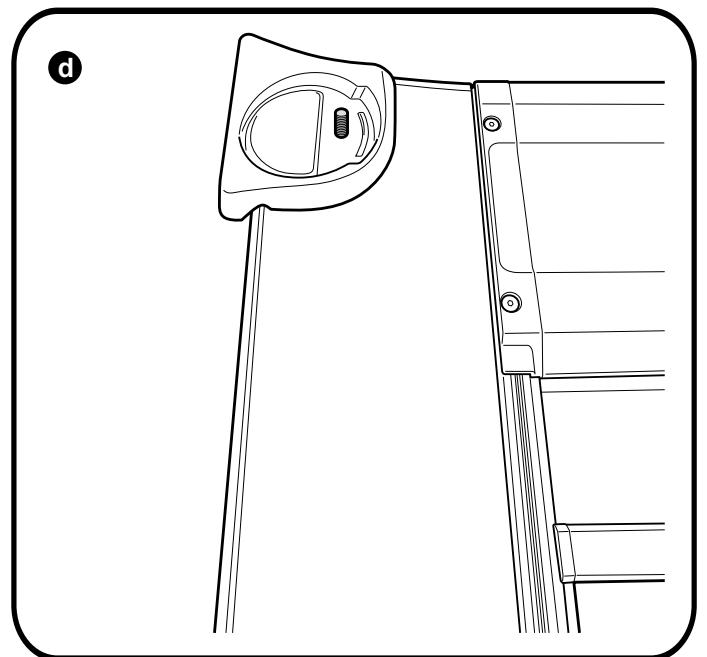
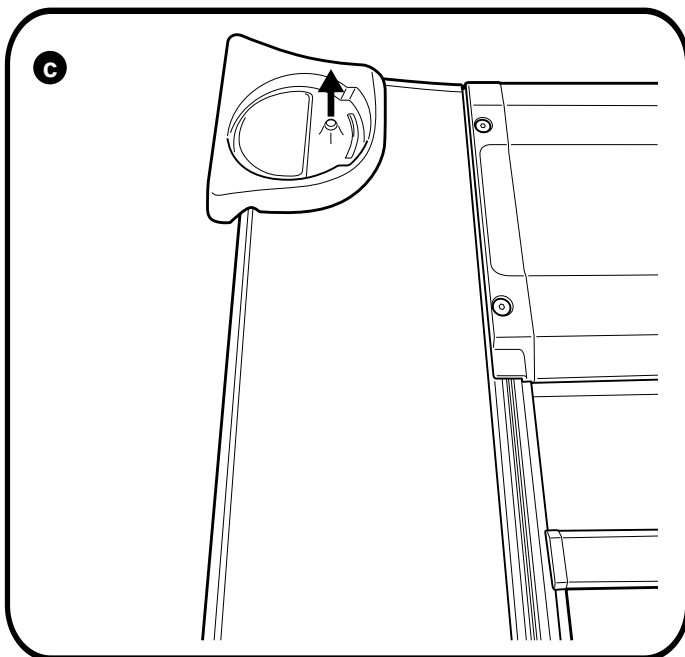
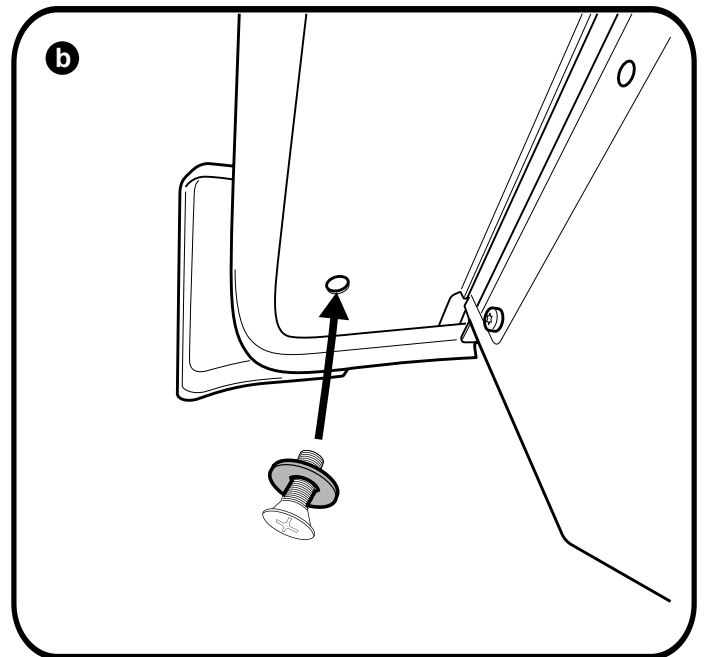
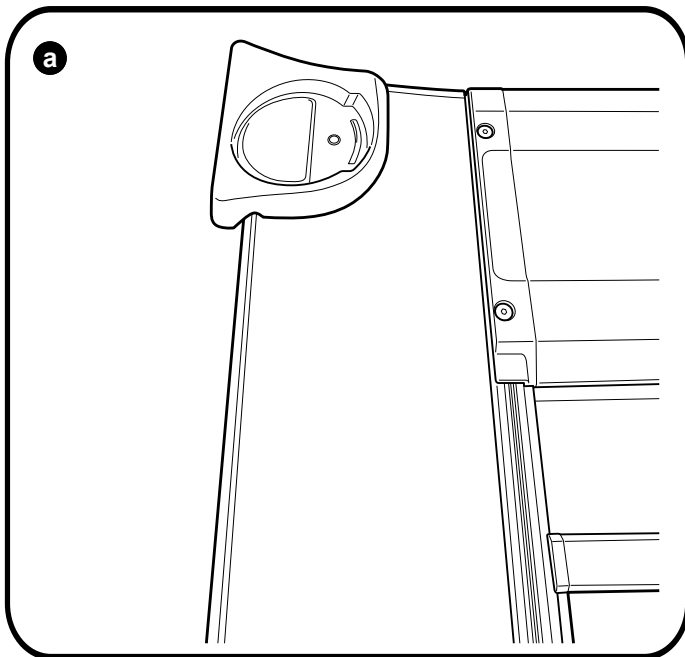
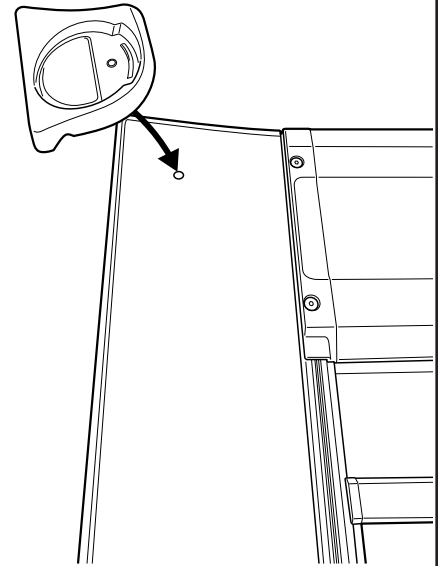

Repeat to the other side.

Position the LHRC (rear left cup) onto the side rail as directed.

- a** Match the circular indentation with the hole on the side rail.
- v** Insert the provided M8x45mm button head bolt through the indicated side rail hole, passing through an M8 spring washer and M8 flat washer.
- w** While holding the cup securely, carefully guide the bolt's thread through the indicated circular indentation.
- x** Completed view.

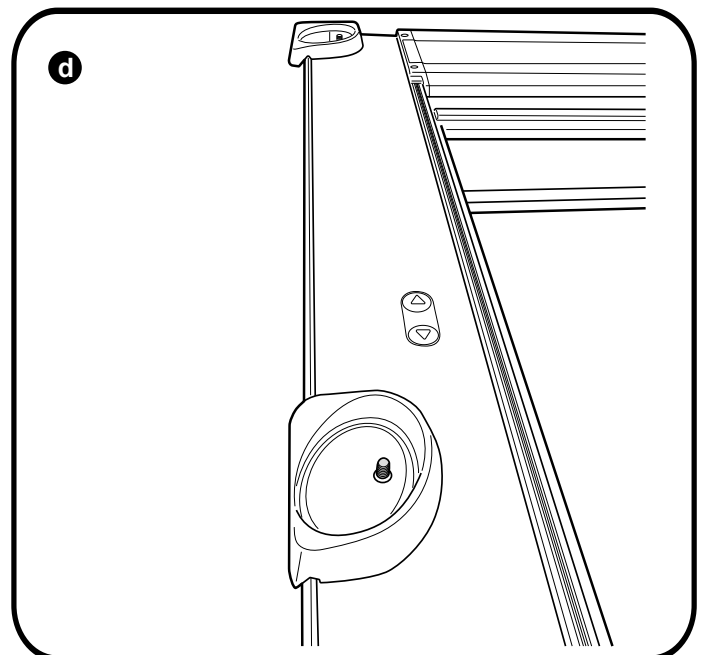
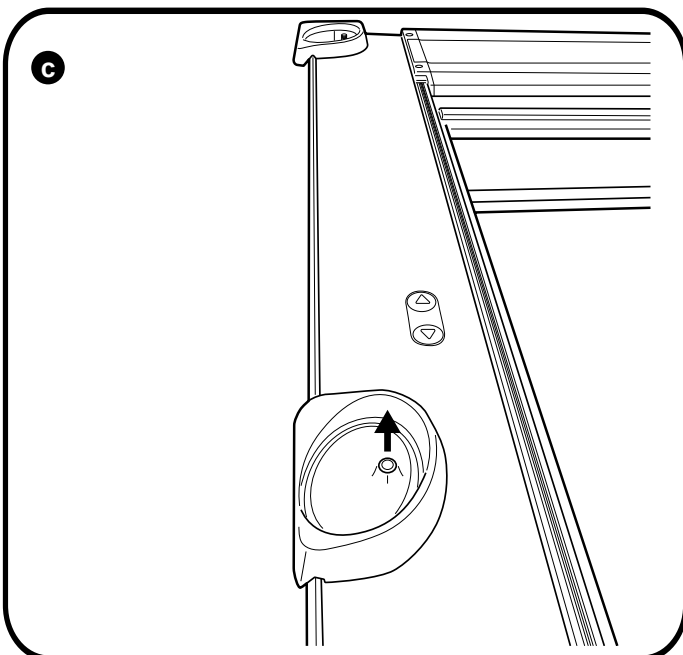
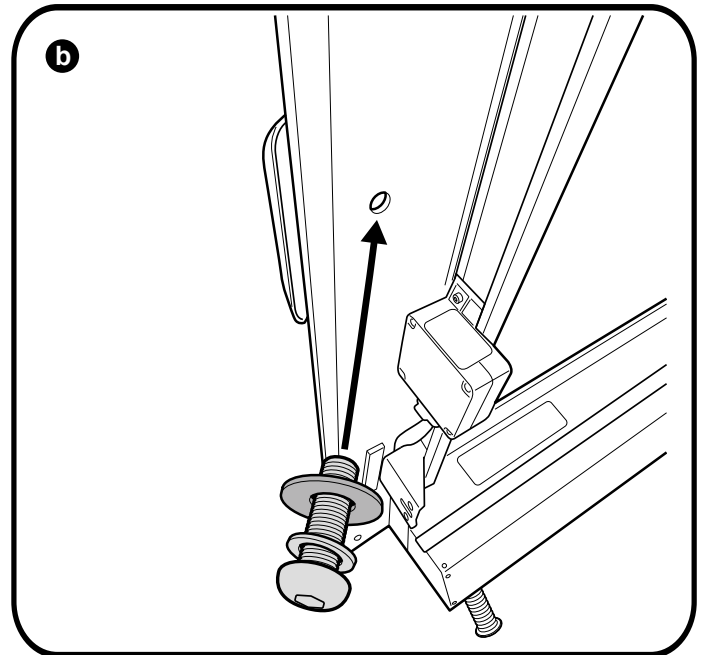
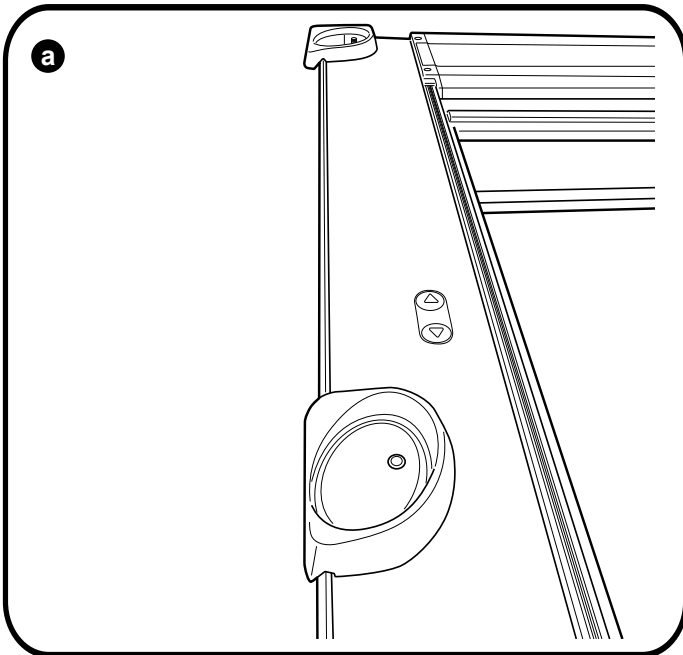
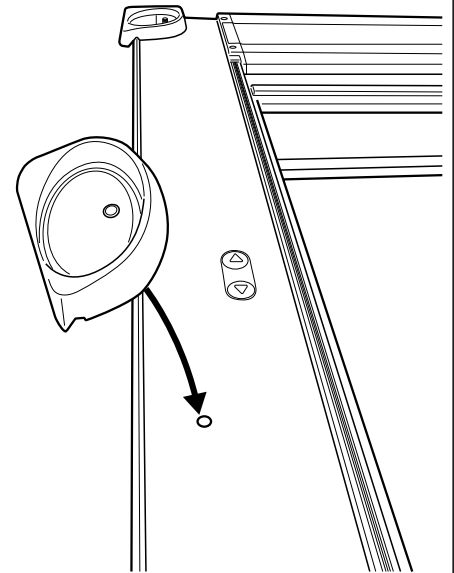

Repeat to the other side.

1. Unfasten the designated bolts, then proceed to remove the bracket along with the original rubber cup. Discard of these components
2. Remove and discard the factory rubber cup.

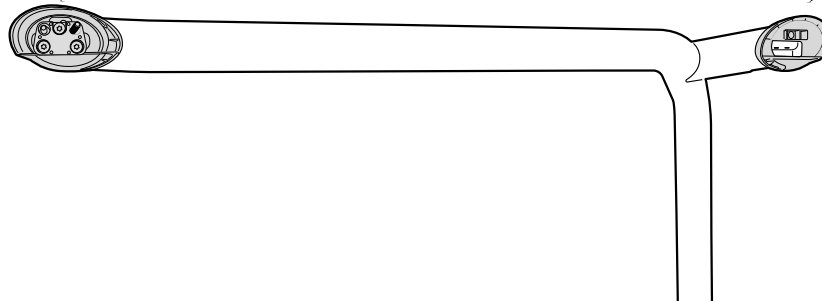
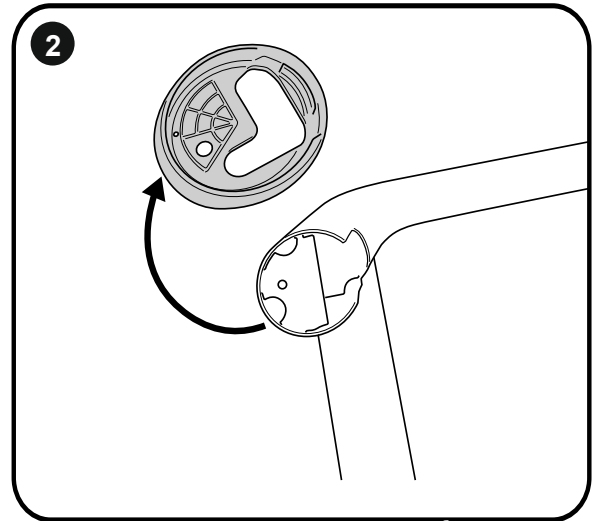
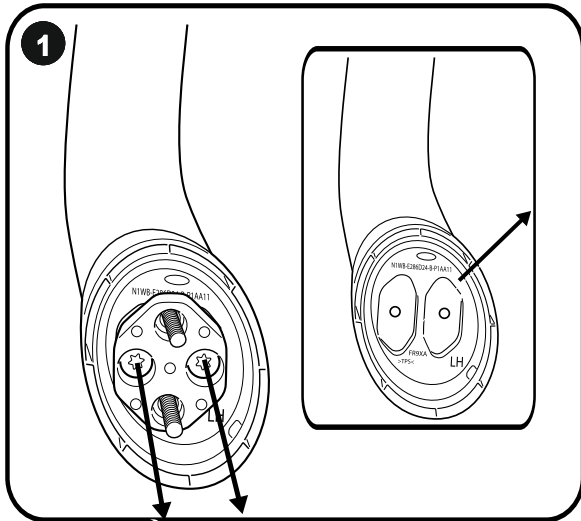

Align the hole and the elongated slot of (NGR-SBB) the brackets with the threads on the sports bars and loosely fasten them using the retaining factory bolts.

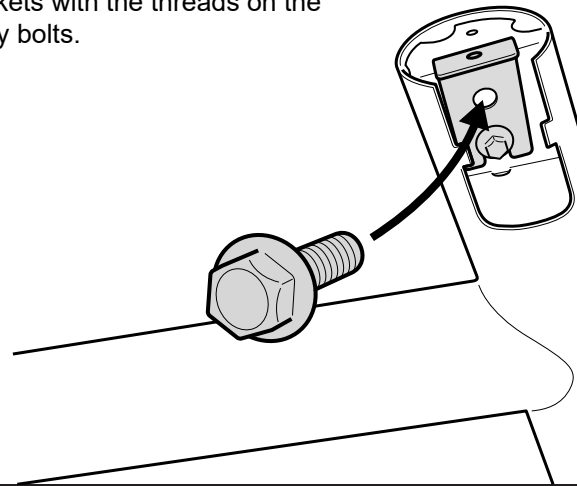

Press bracket down and hold level.  
Fasten indicated bolts.

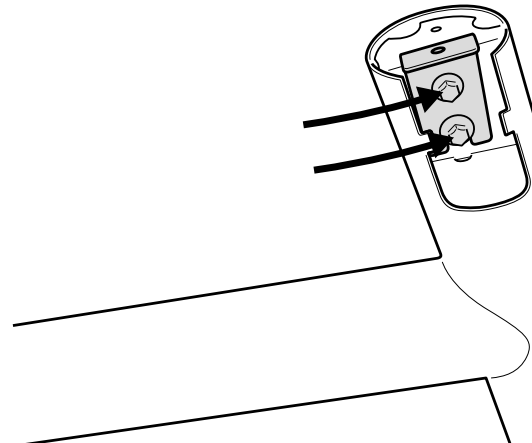

Handle with care and with assistance, position the sports bars on top of the side rails, ensuring they fit within the rubber cups.

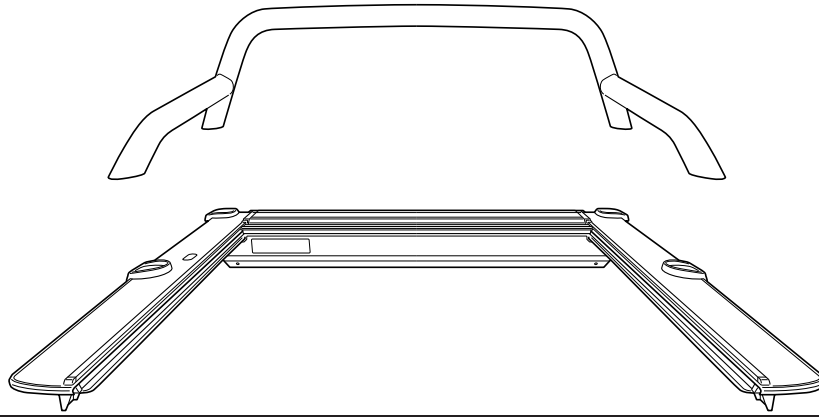

Slide the front rubber cups towards the middle of the roll top, ensuring that the inner edge of the cup fits tightly against the sports bars.

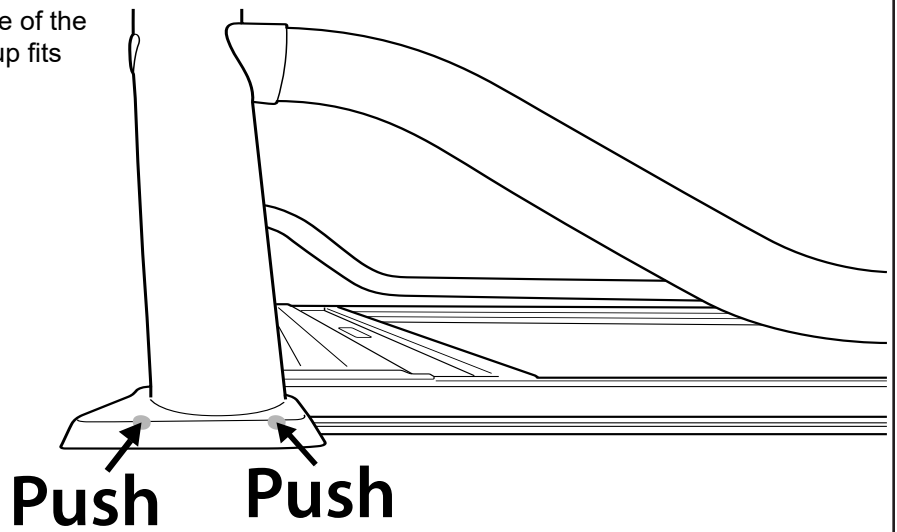

Slide the rear rubber cups towards the outside of the roll top, ensuring that the inner edge of the cup fits tightly against the sports bars.

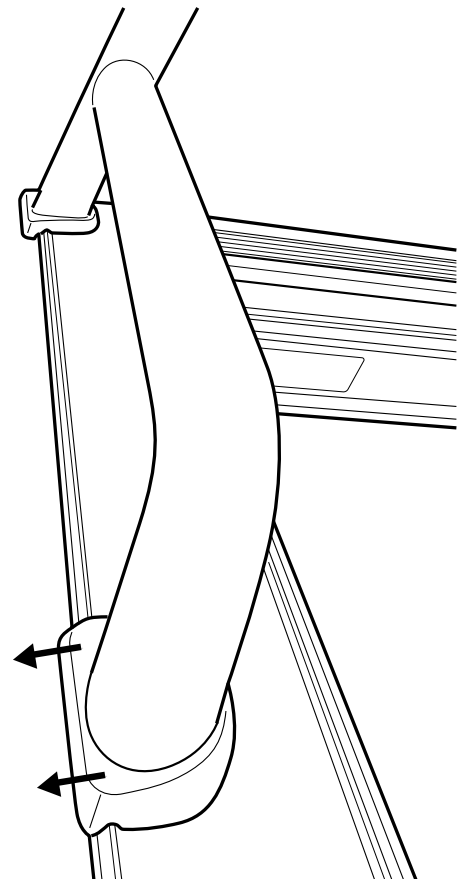

- a** If necessary, you can slightly loosen the specified bolts to facilitate the alignment of the M6 bolt through the side rail with the thread of the NGR-SBB bracket.

Gently position the rubber cups on the side rail and sports bars, ensuring they rest naturally in their intended shape.

- v** Gently position the rubber cups on the side rail and sports bars, ensuring they rest naturally in their intended shape.

- w** Secure the specified bolts with caution to a torque of 3Nm into the legs of the sports bar.

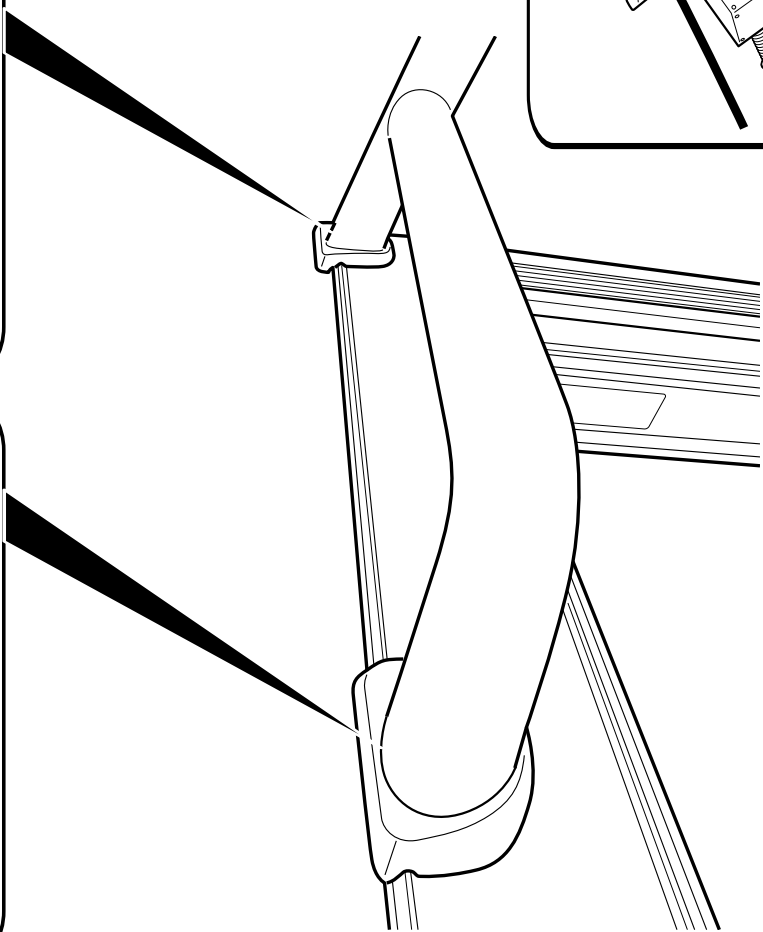
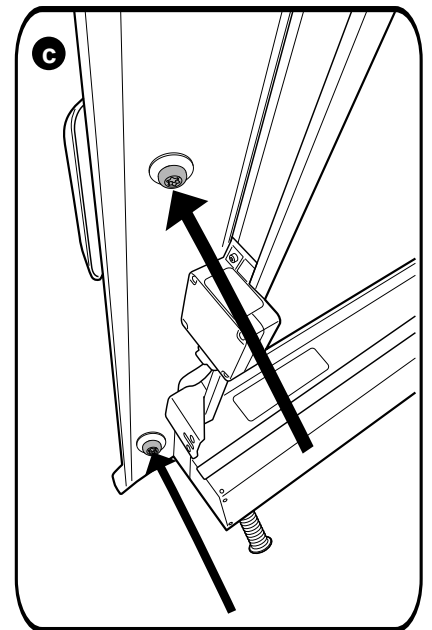
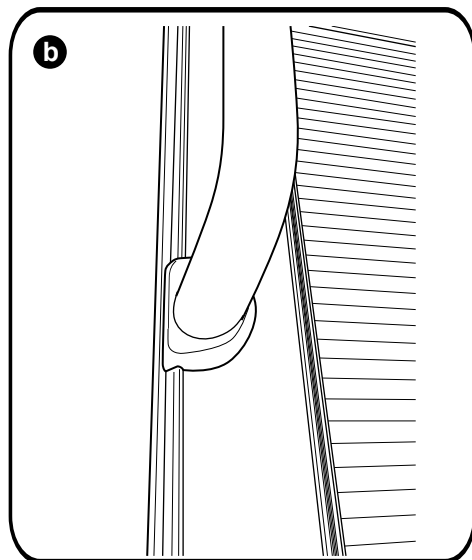
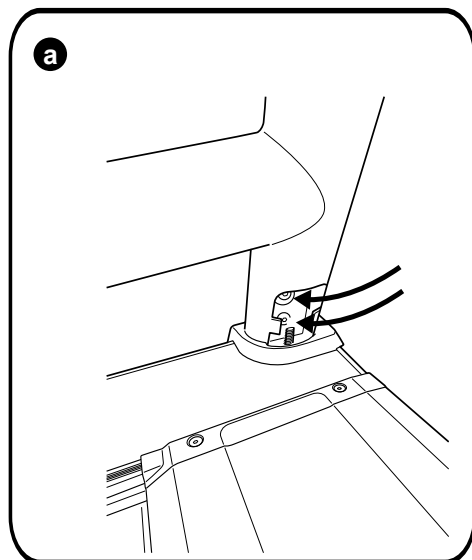

Place the Roll-R-Cover unit on to Ute bed.

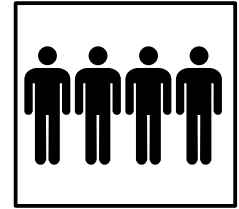
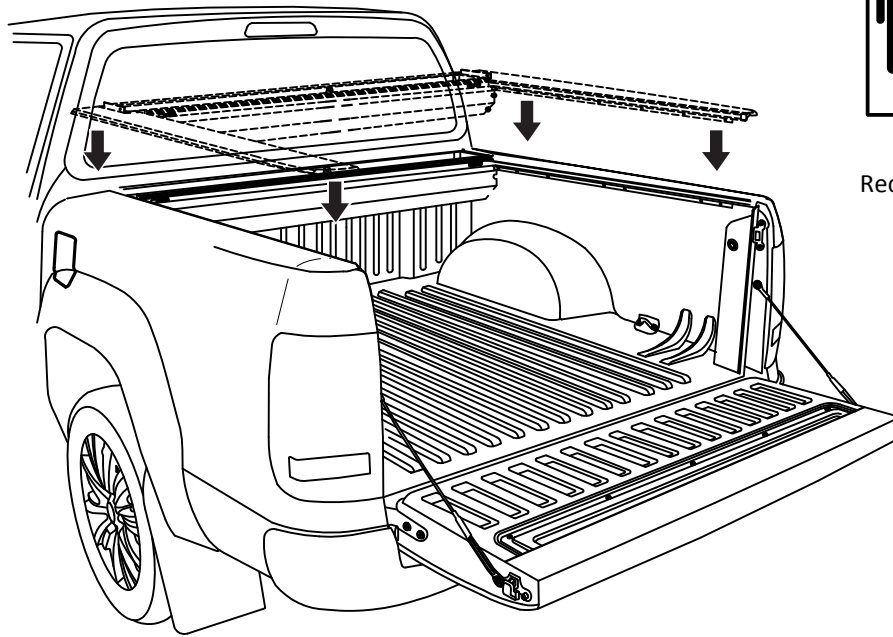

4 People  
Recommended for lift

With care, pull out any side rubber  
that has folded under the side rail.

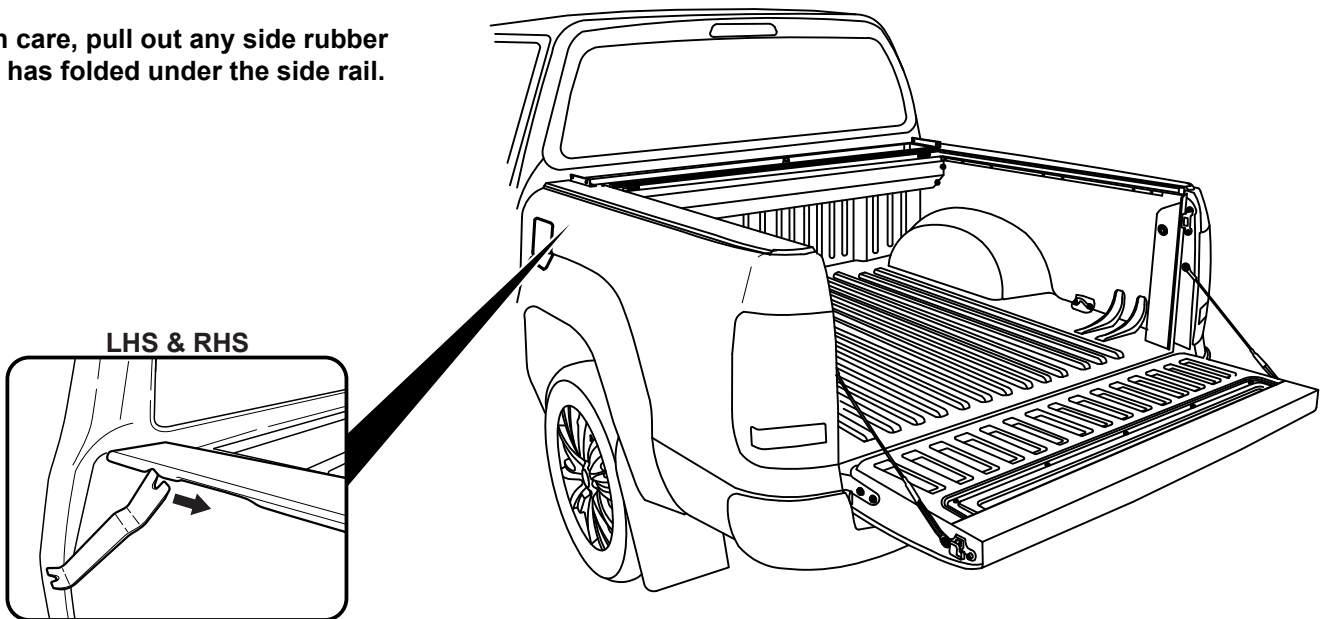

LHS & RHS



With the tailgate up (Closed position), Pull left & right hand side rails towards the tailgate, stopping short by 7mm between tailgates plastic top covers inner wall and side-rail end-cap.

 Foam compressed to 7mm when tailgate is closed.

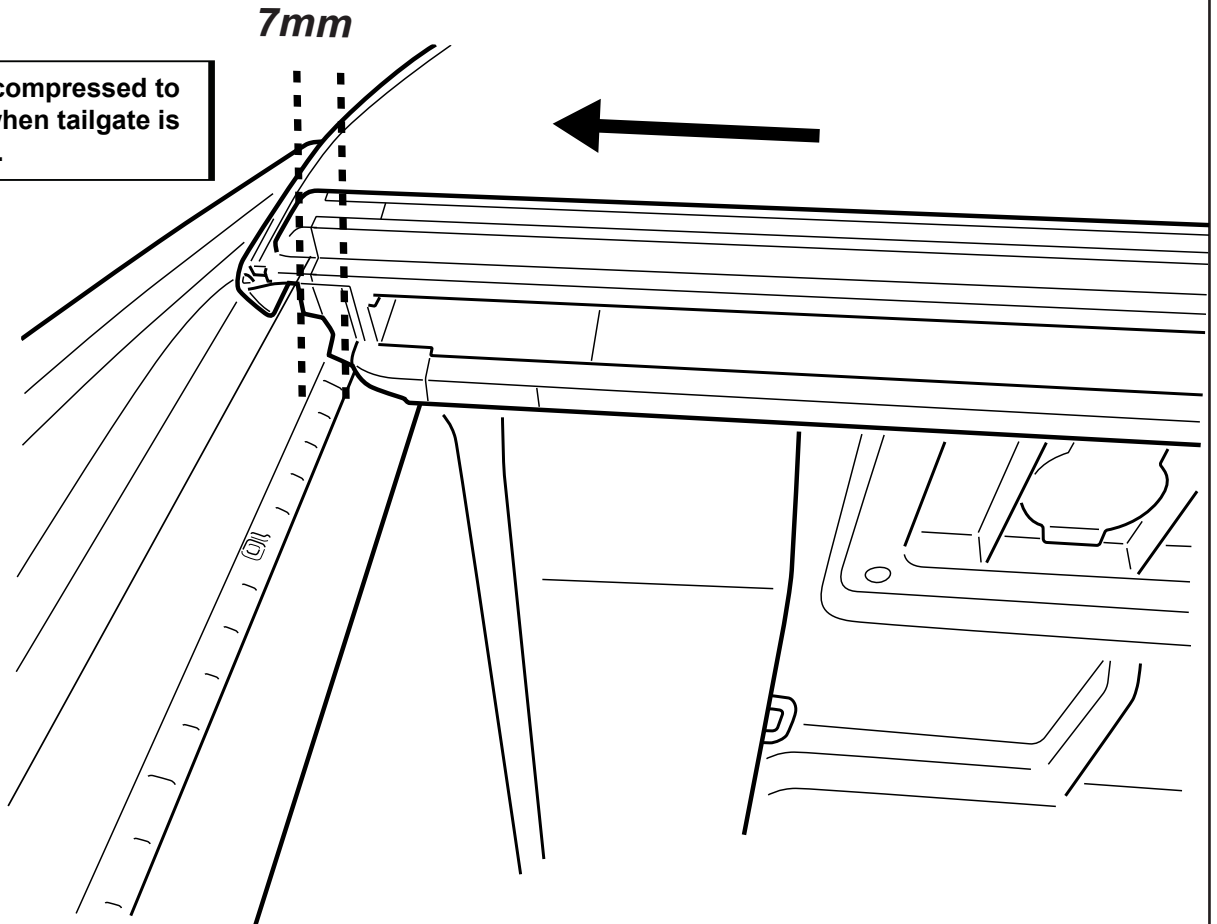

Gap between tailgate and side-rail end cap to be 7mm.

Side rail end cap

 Foam compressed to 7mm when tailgate is closed.

Foam seal

TAILGATE

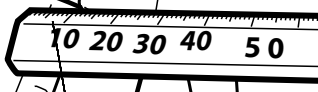

7mm

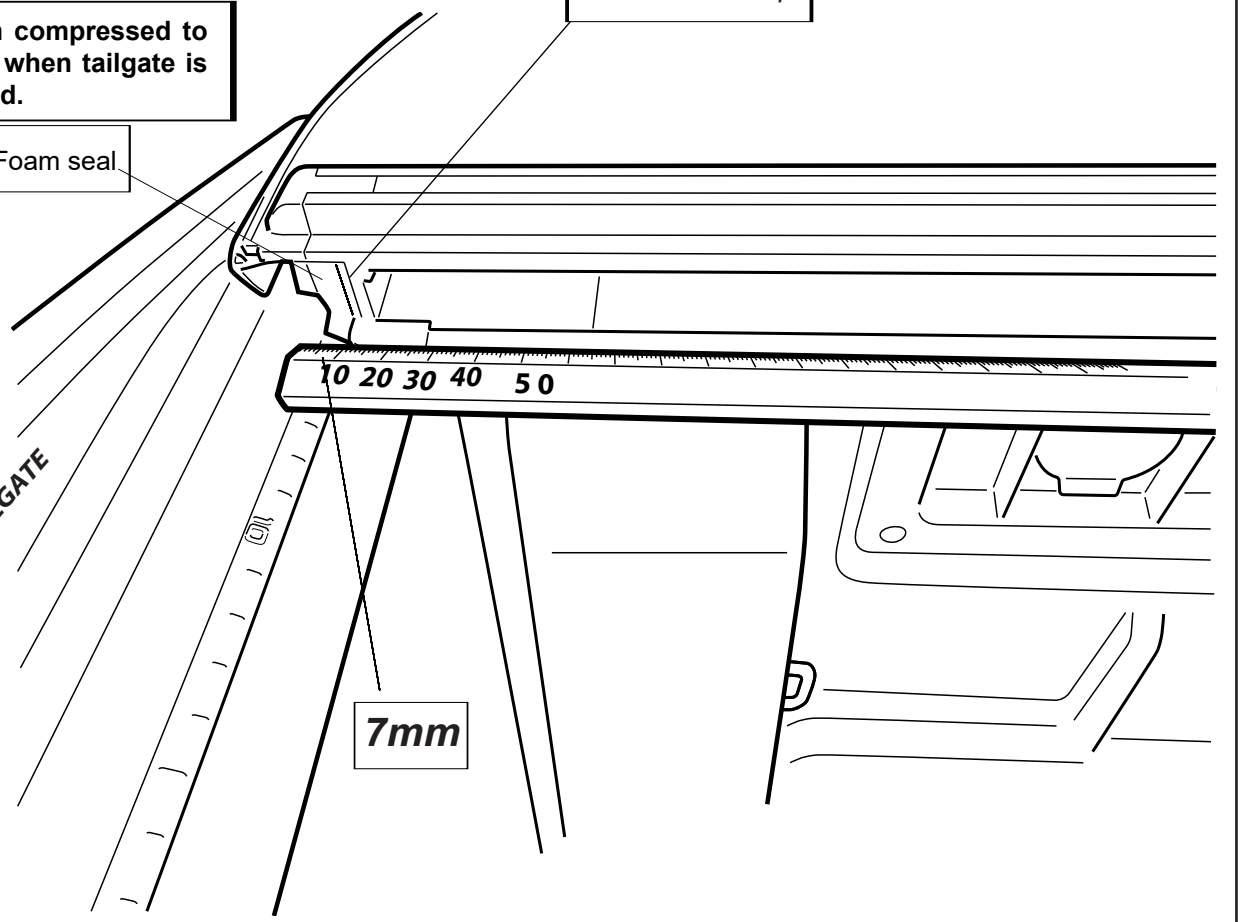

Locate spacers with 1 notch to the areas indicated.  
Push the spacer up and level with the side rail clamp bracket as indicated.

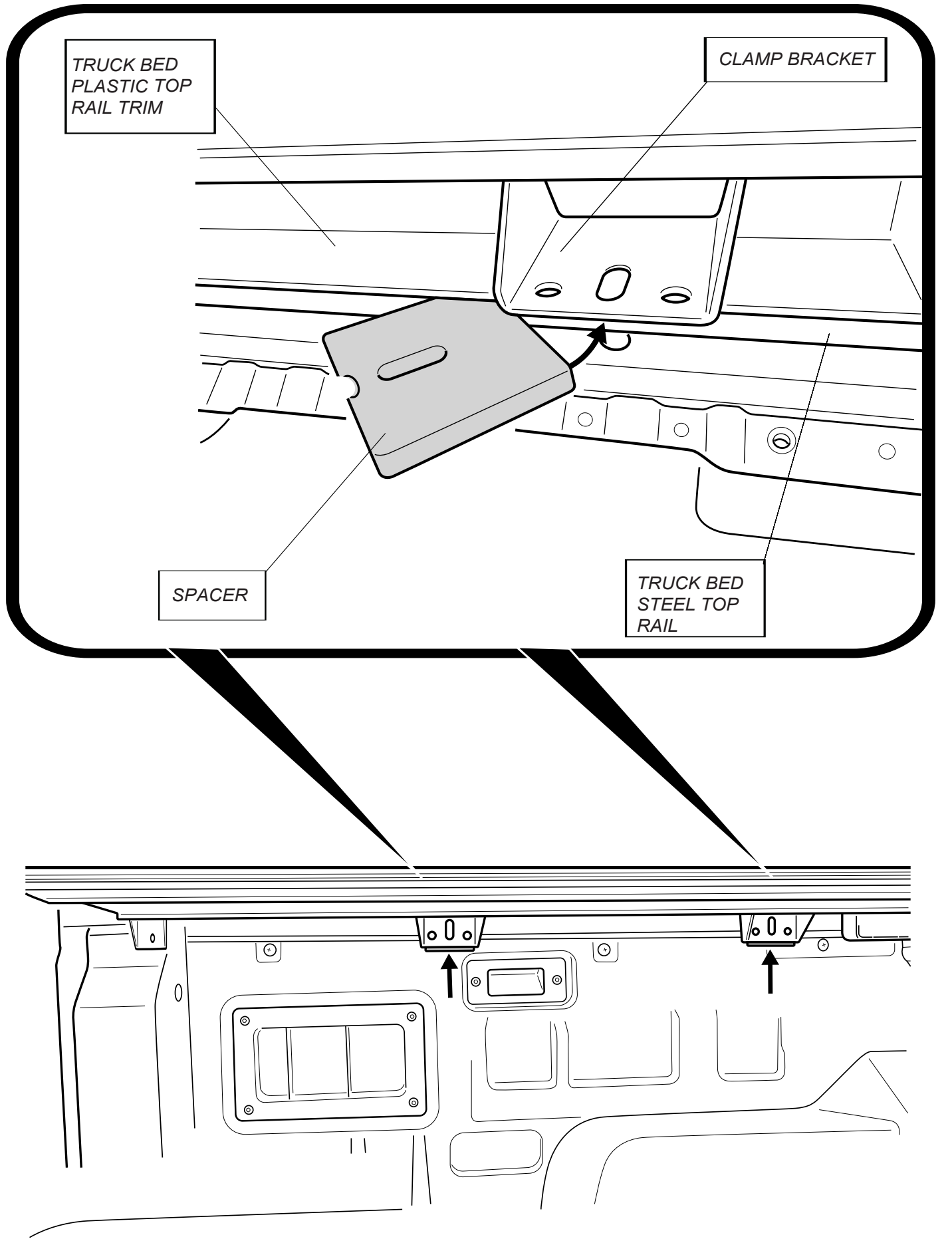

1. Rear brackets elongated hole will line up with the thread in the body as indicated.
2. Feed M6x25mm hex head bolt followed by M6 spring washer and M6 flat washer through bracket and loosely fasten to the thread of the ute bed.

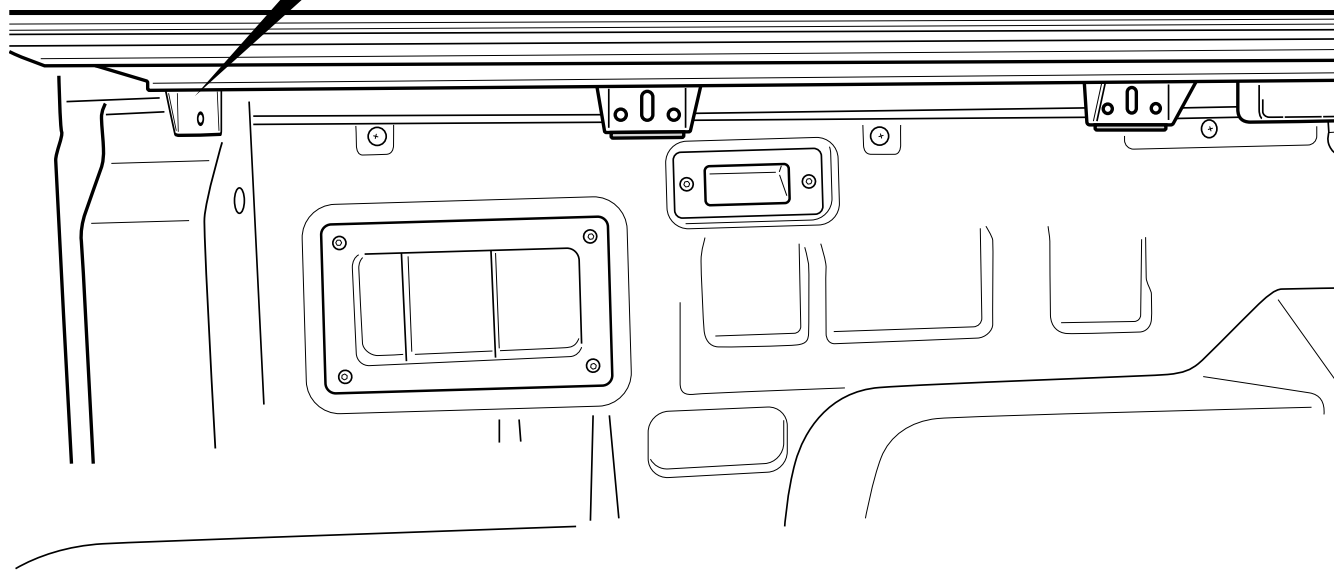
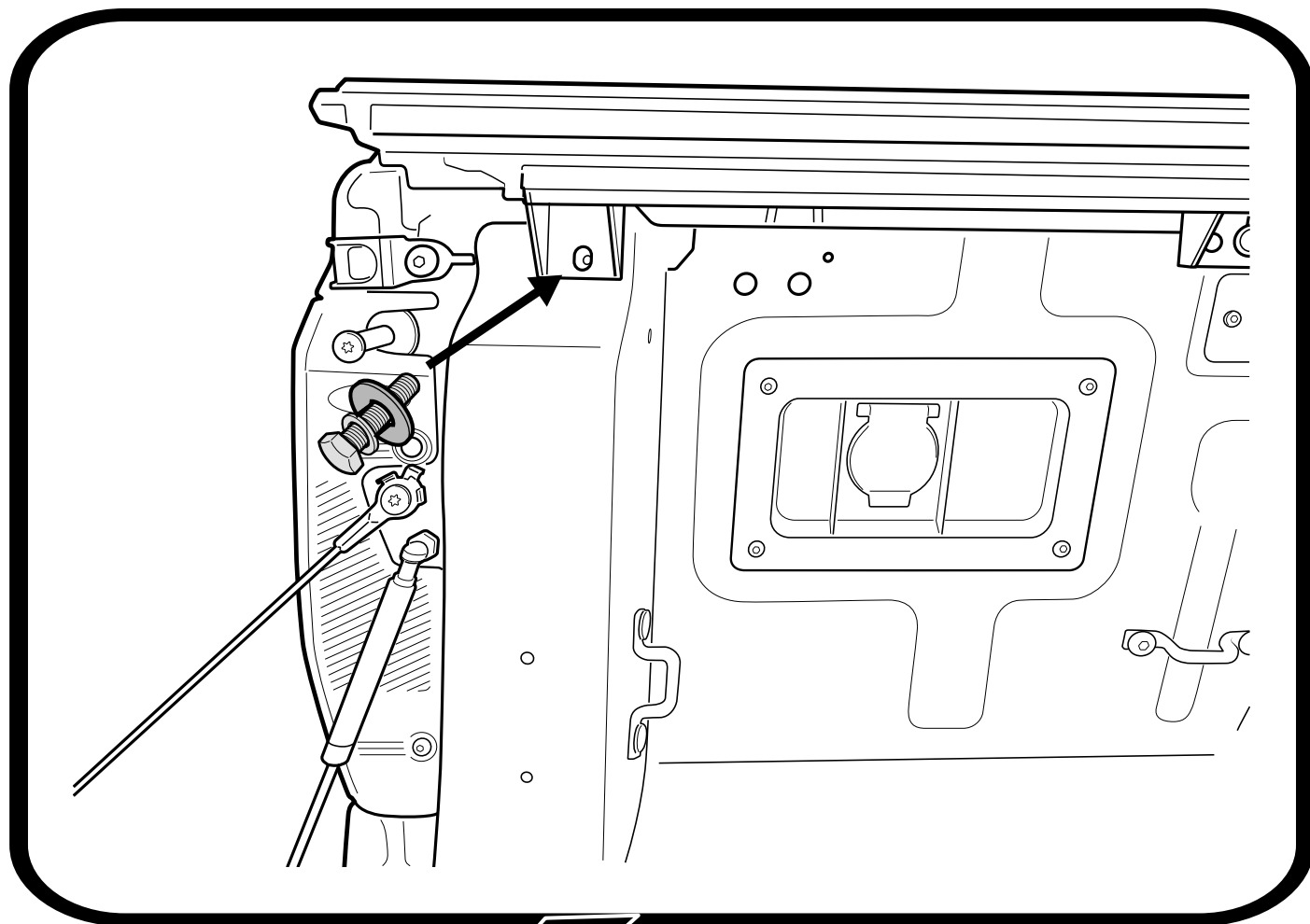

Position clamp behind the inner top lip of the bed rail and the center elongated hole of the side rail mounting brackets. Repeat to other side.

Ensure the M8 nut is in the indicated slot of the clamp

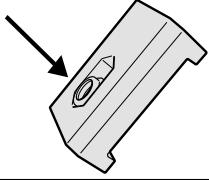

Fasten clamp loosely into position using M8 washer, M8 spring washer and M8 x 35mm bolt.

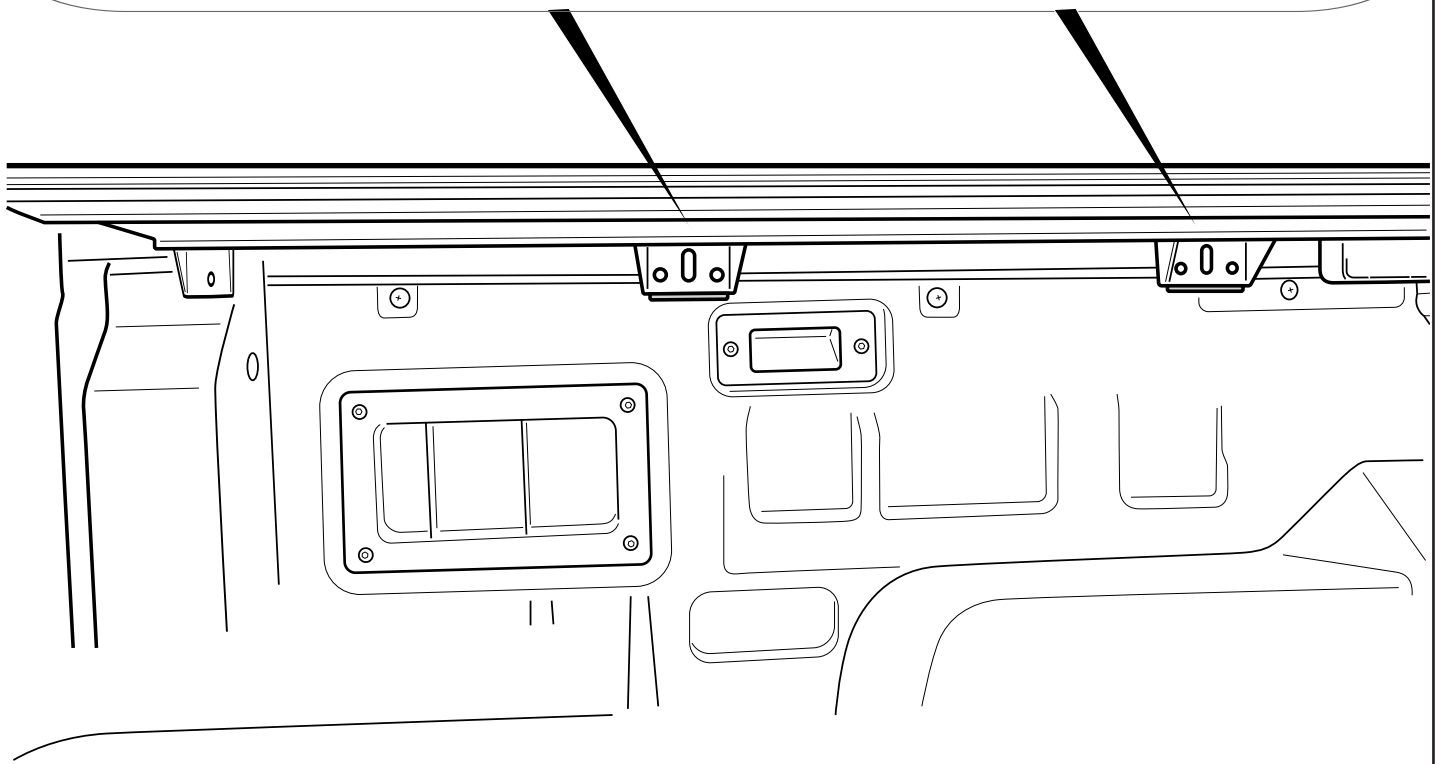
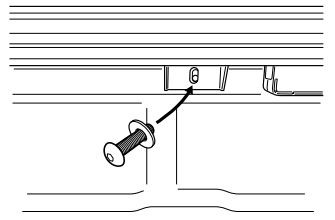

Please follow the steps in order starting with point 1.

1. With assistance apply down pressure to the side rail surface. Keeping that position, now fasten the M6 x 25mm hex bolt to 8Nm torque.
2. Making sure the black spacer is still in-line with the bottom of side rails clamp bracket, push clamps up as far as possible into the inner rail of the tub and fasten bolts to 10Nm torque.
3. Making sure the black spacer is still in-line with the bottom of side rails clamp bracket, push clamps up as far as possible into the inner rail of the tub and fasten bolts to 10Nm torque.

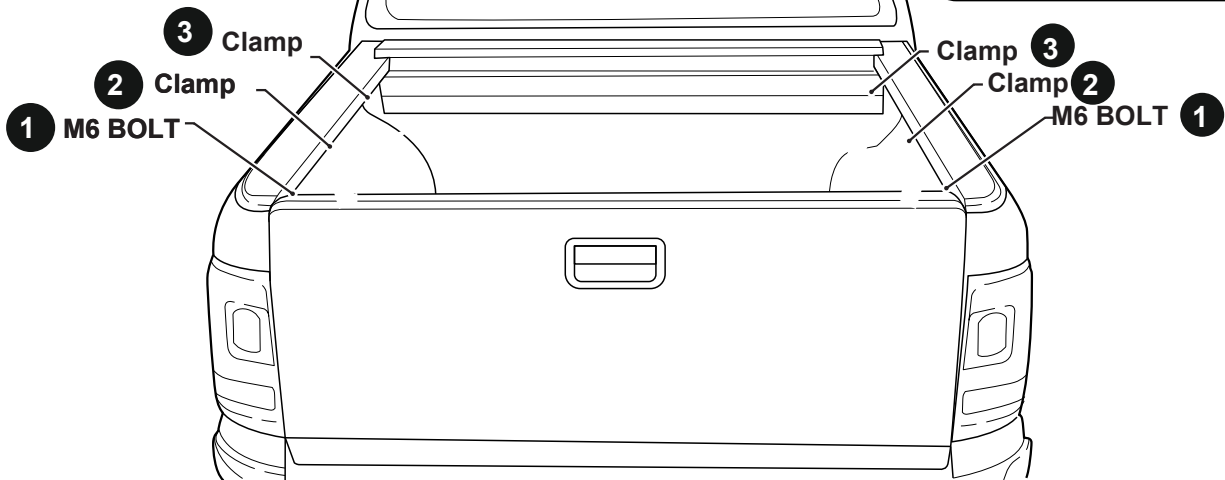
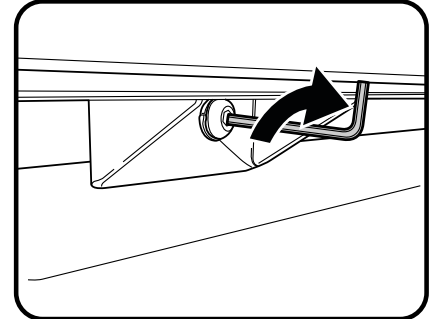
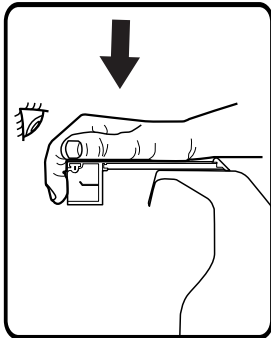

Side rail to sit level, side rail seal will sit below the top of the tailgate in the closed position.

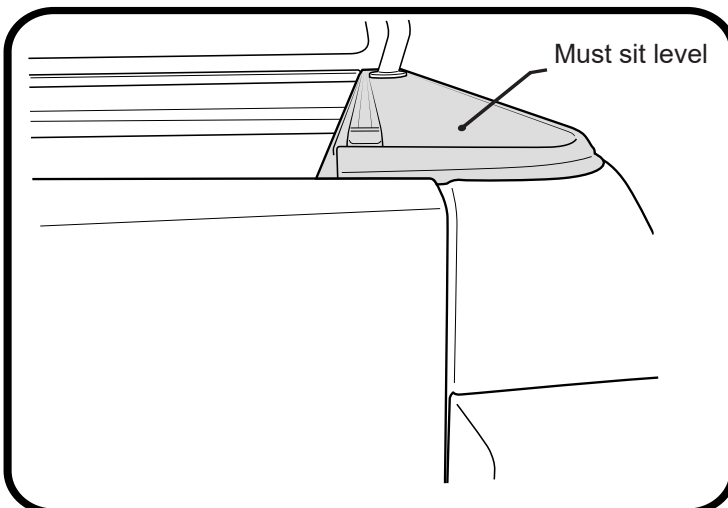

If required M6 hex bolt can be loosened to push the side rails further down or lift up. Fasten bolt to 8Nm torque.

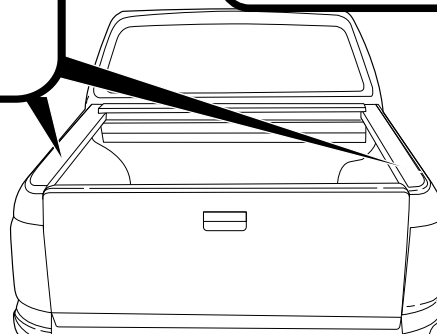
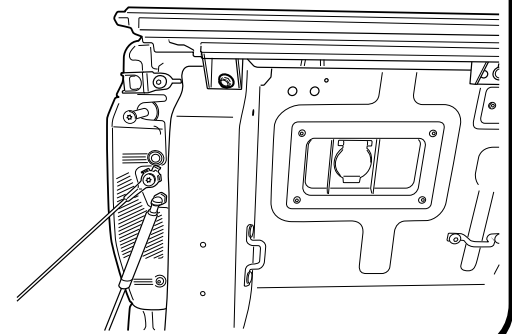

Siderail seal will sit tucked in at indicated position of the the tailgate plastic trim.

Siderail seal.

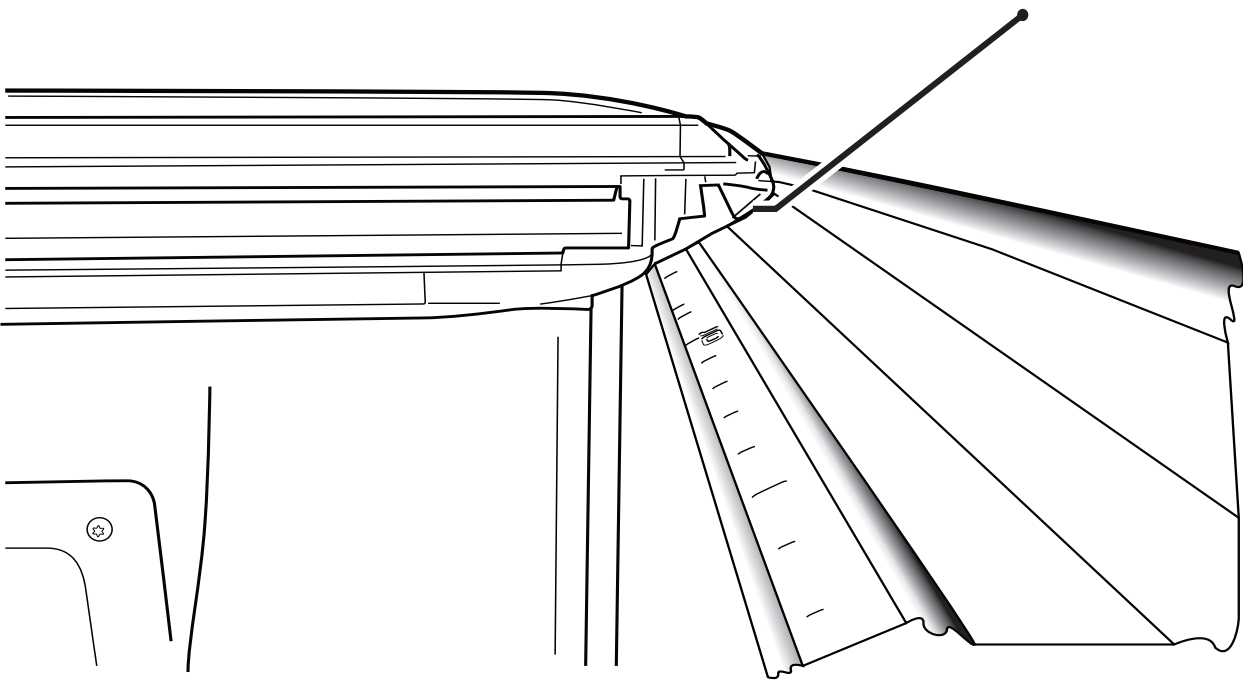

The rubber feet cups bottom should be positioned near the top surface of the tub's rail plastic trims. If this isn't the situation, you can adjust by loosening the specified bolts.

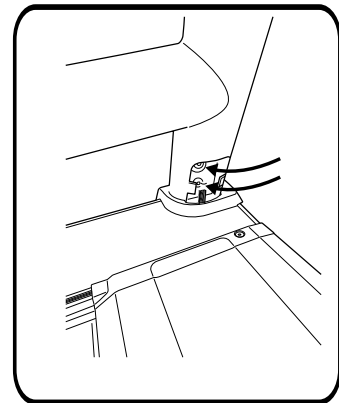
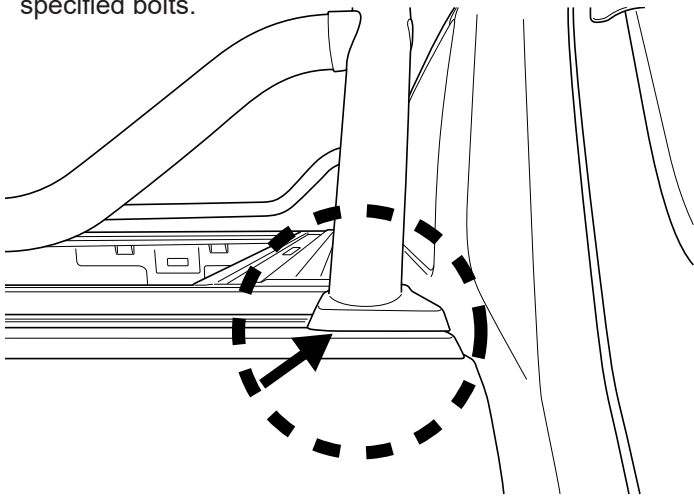

Adjust the rubber feet cups carefully, and then use assistance to push the sports bars downwards at the specified position. While keeping them in position, secure the designated bolts."

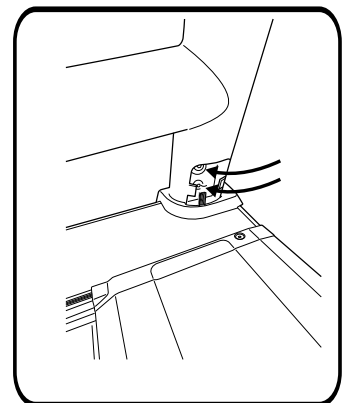
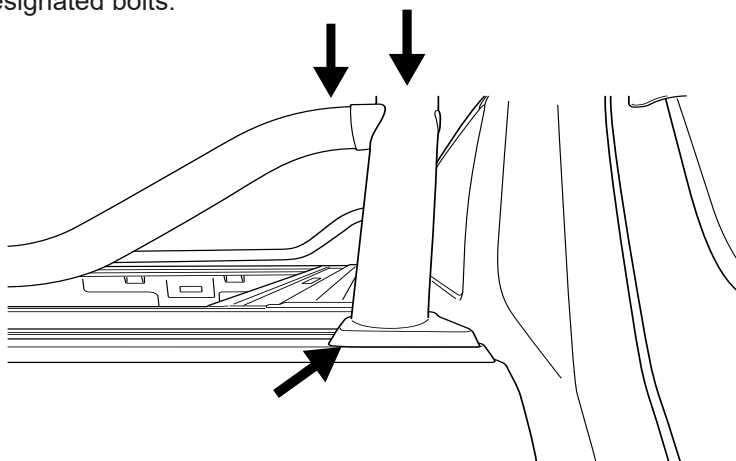

Re-fit cover.

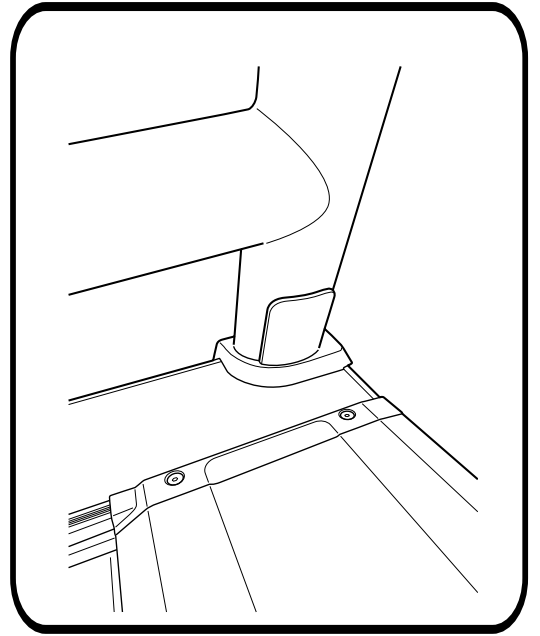
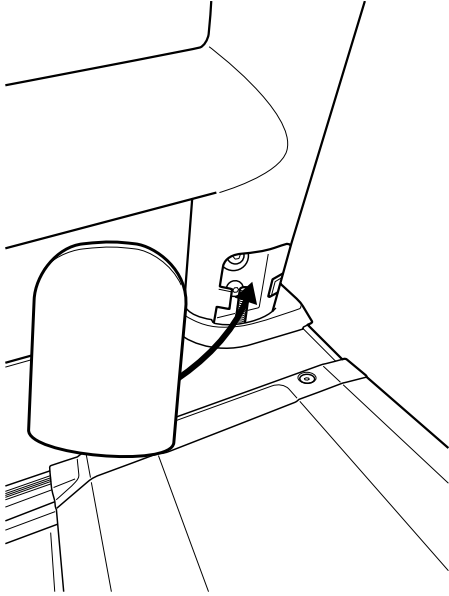

**Install front drain pipes through pre-drilled holes of the canister. ( RHS/LHS)**



Note: With care push tube in. Gently pull the tube back so it seals correctly against the front panel of the tub.



 **VISUAL TIP**

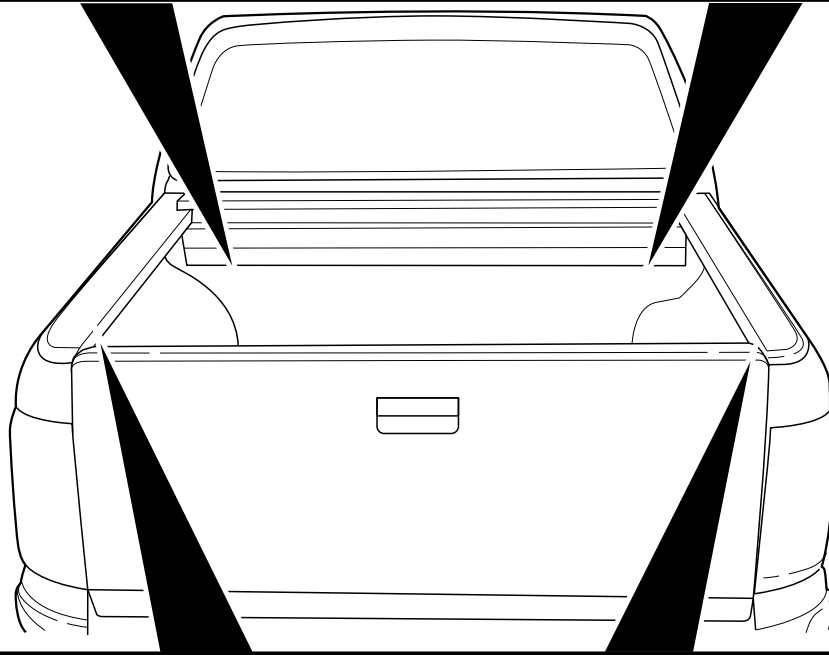
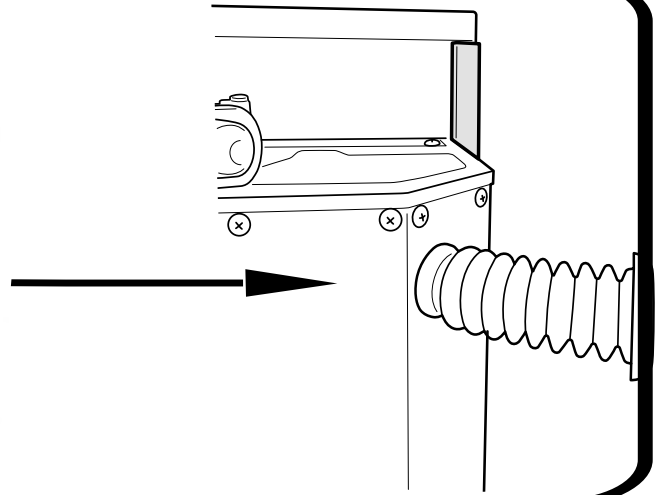
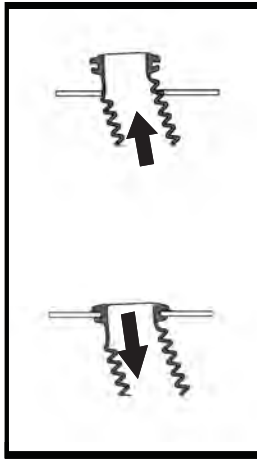

Note: With care push rear pipe in. Gently pull the pipe back so it seals correctly within the side rail channel.

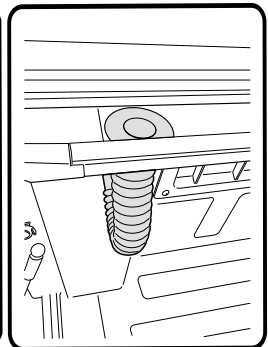
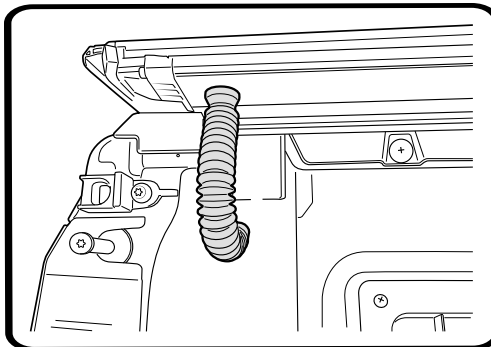
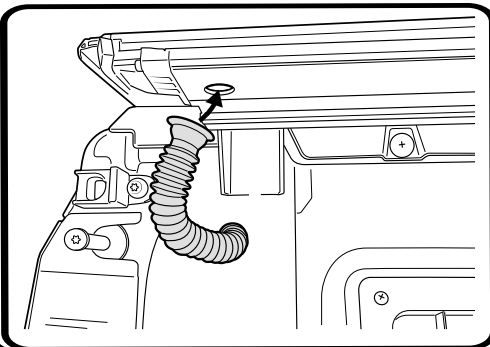
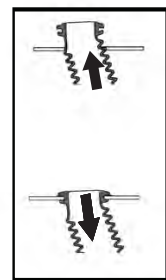

**Install rear drain pipes through pre-drilled holes of the siderails. ( RHS/LHS)**



- a. Connect Battery loom S2.75 to Receiver loom.
- b. **Carefully** connect CI-Loom-short to Receiver loom.



Align connectors carefully to avoid pushing pins out.

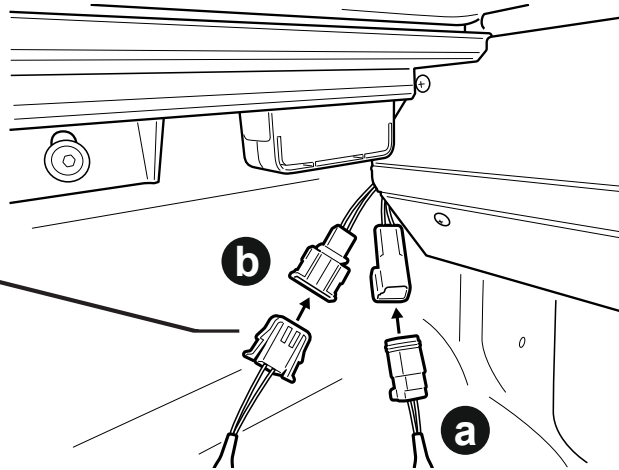

NOTE: 1. To wear in the Roll R Cover please fully open & close the cover approximately 15 times after install is complete.

2. Set your vehicle locking system to unlock all doors with one press of the factory remote unlock button. This setting can be found in your vehicle settings.

### Operating instructions:

Press unlock on vehicle key fob to activate controller.

When vehicle is unlocked the side rail sensor buttons will be active to control.

When vehicle is locked the side rail sensor buttons will be inactive.

### Using factory key fob to operate:

Pressing unlock twice on the factory key fob within 4 seconds, will activate the roll r cover to open.

Pressing lock twice on the factory key fob within 4 seconds, will activate the roll r cover to close.



### Vehicle proximity:

Tapping the proximity twice to open or lock the car door will act exactly the same way as the key fob being pressed twice.

Touch & let go to open, touch & let go again to pause.

Touch & let go to close, touch & let go again to pause.

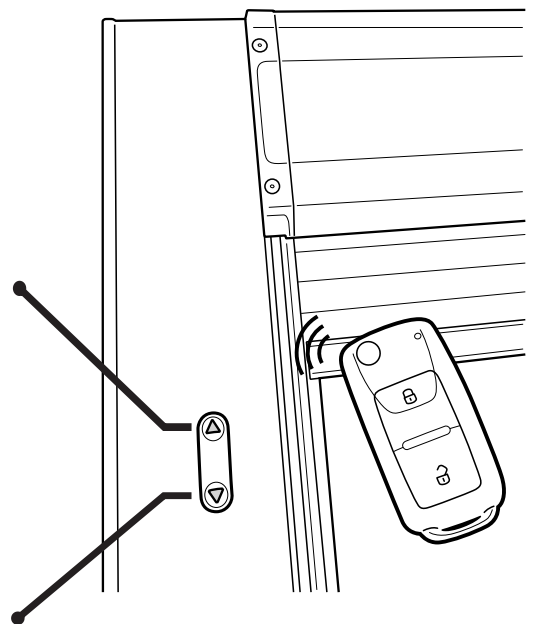

Trouble shooting visual tips:

side rail Parallel test

