



INSTALLATION INSTRUCTIONS

**Vehicle Model: FORD RANGER - PX
2011 onwards, & FORD RANGER
RAPTOR**



INSTALLATION TIME: 1 hours and 45 minutes (Approximately)

IMPORTANT	<ul style="list-style-type: none"> • Do not stand/sit or rest heavy objects on Roll R Cover • Humans or animals are not to be under the closed cover at any given time • Tonneau Cover is not dust or water tight • If contact with volatile chemicals occur, clean Cover with mild detergent and water solution 			
Care Instructions	<ul style="list-style-type: none"> • Read Instructions fully before commencing installation. • Clean Cover with a mild detergent and water solution • Do not use abrasive cleaners or solvents • Refer to manufactures instructions applicable to power drill. • Protect Tub floor against scratches during installation process. 			
Maintenance	Refer to Maintenance instructions.			
Tools Required	<table style="width: 100%; border: none;"> <tr> <td style="vertical-align: top;"> <ul style="list-style-type: none"> • Pen / Marker • Centre Punch • Drill & Drill bits • Caulking Gun • Silicon - Non Acetic </td> <td style="vertical-align: top;"> <ul style="list-style-type: none"> • Scissors & Knife • Spanner & Socket • Tape measure • Holesaw • Filing tool </td> <td style="vertical-align: top;"> <ul style="list-style-type: none"> • Soapy water solution • Allen Key set • Screw driver • Rust Inhibitor • Trim Removal Tool </td> </tr> </table>	<ul style="list-style-type: none"> • Pen / Marker • Centre Punch • Drill & Drill bits • Caulking Gun • Silicon - Non Acetic 	<ul style="list-style-type: none"> • Scissors & Knife • Spanner & Socket • Tape measure • Holesaw • Filing tool 	<ul style="list-style-type: none"> • Soapy water solution • Allen Key set • Screw driver • Rust Inhibitor • Trim Removal Tool
<ul style="list-style-type: none"> • Pen / Marker • Centre Punch • Drill & Drill bits • Caulking Gun • Silicon - Non Acetic 	<ul style="list-style-type: none"> • Scissors & Knife • Spanner & Socket • Tape measure • Holesaw • Filing tool 	<ul style="list-style-type: none"> • Soapy water solution • Allen Key set • Screw driver • Rust Inhibitor • Trim Removal Tool 		

PERSONAL PROTECTIVE EQUIPMENT:



Rubber Gloves



Goggles



Hearing Protection

BOX CONTENTS

LEFT & RIGHT SIDE RAIL

S2.5-DC-AE-002ps-P4 

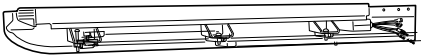
S2.5-DC-AE-003ds-P4 









CANISTER ASSEMBLY

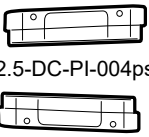



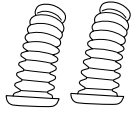
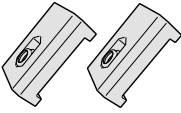
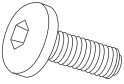

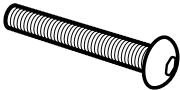

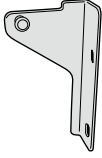
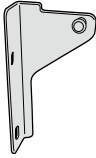

S3-DC-AF-P4R_B4R-001/002

CANISTER TOP COVER  S2.5-DC-AE-005 -P4

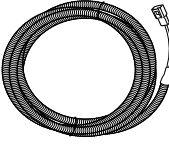
STANDARD KIT

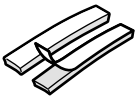
<p>COVER END CAPS</p>  <p>S2.5-DC-PI-004ps S2.5-DC-PI-004ds</p>	 <p>COUNTERSUNK SCREW Qty - 4</p>	 <p>FLAT PLATE Qty- 2</p>	 <p>CABLE TIE Qty x 16</p>	 <p>BATTERY LOOM S2.75</p>	 <p>Drainage pipe Qty - 2</p>
 <p>SIDERRAIL CLAMP Qty - 6</p>	 <p>M8 x 35mm Qty - 6</p>	 <p>M8 WASHER Qty - 6</p>	 <p>M8 SPRING WASHER Qty - 6</p>	 <p>M8 x 70 mm Qty - 2</p>	 <p>M8 NUT Qty - 8</p>
 <p>Rear Drainage pipe Qty - 2</p>					

SPECIFIC KIT P4R

 <p>RBRH</p>	 <p>RBLH</p>	 <p>M6 x 20 ALLEN Head Bolt Qty - 2</p>	 <p>M8 x 20 ALLEN Head Bolt Qty - 4</p>	 <p>CL-LOOM-SHORT</p>	 <p>P-PATCH-K</p>
 <p>50449 D-SPONGE Qty-2</p>	 <p>TAPE Qty -4</p>	 <p>Foam seal Qty - 1.7m</p>	 <p>3M PRIMER</p>	 <p>Clear protective tape (30mm x 65mm) Qty - 2</p>	

TUB PREPARATION

If the Vehicle is fitted with a cabin guard or sports styling bar, remove from Ute Tub (truck bed).

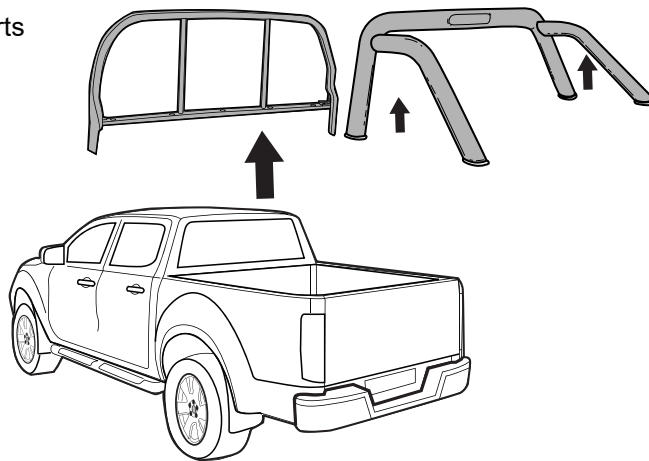

Clean area as indicated.

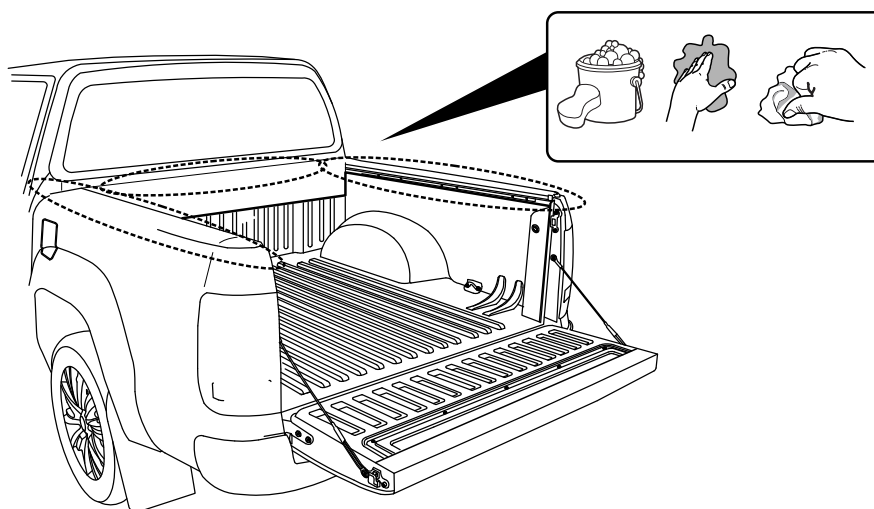

Measure 10mm down from top of tailgate and trim tailgate liner.

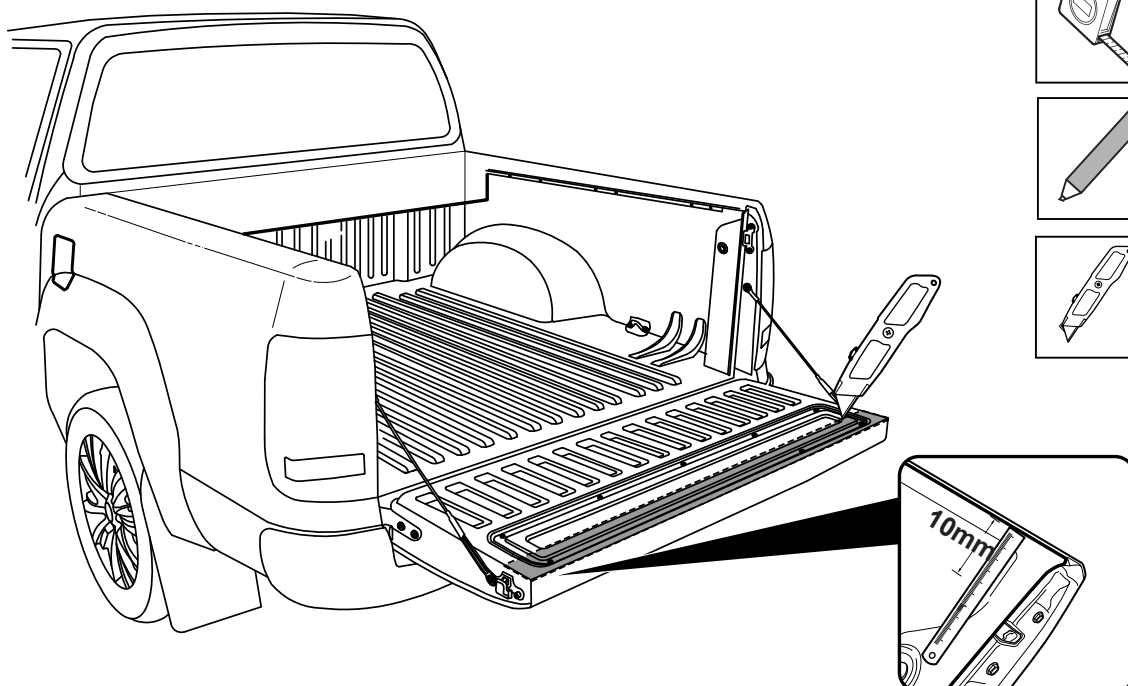

Remove 12V unit by unfastening the factory screw, and unplug from loom.

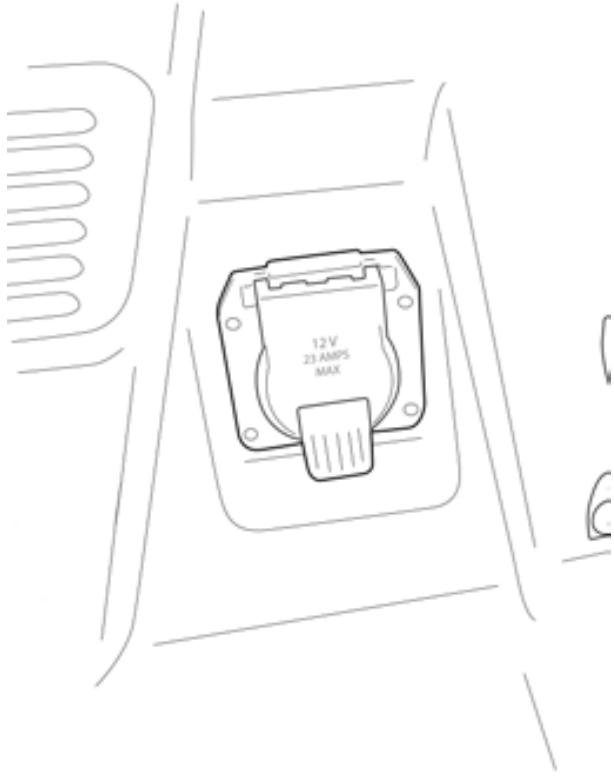

Remove thread clips and retain.

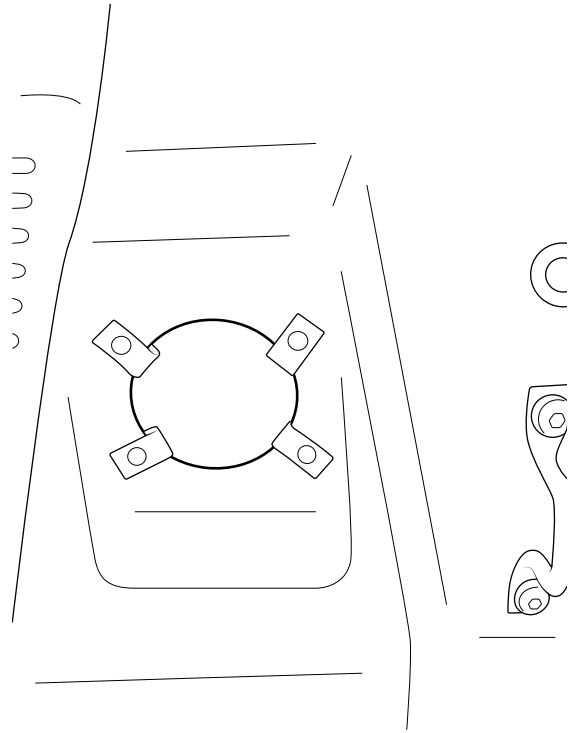

- 1. Rotate 12V unit as indicated and move unit all the way down.**
- 2. Mark and drill all screw points.**

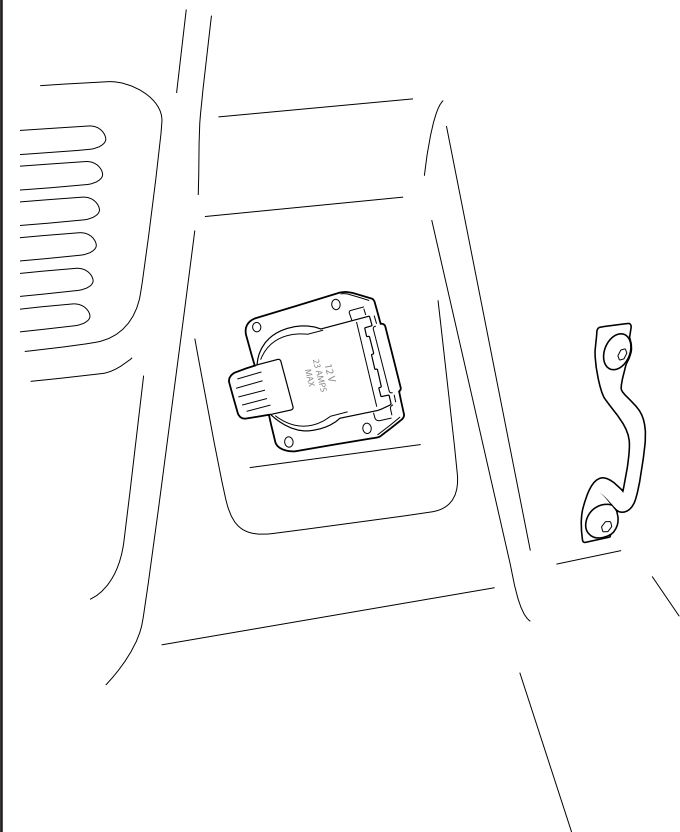

Fasten into position using factory screw and screw clips.

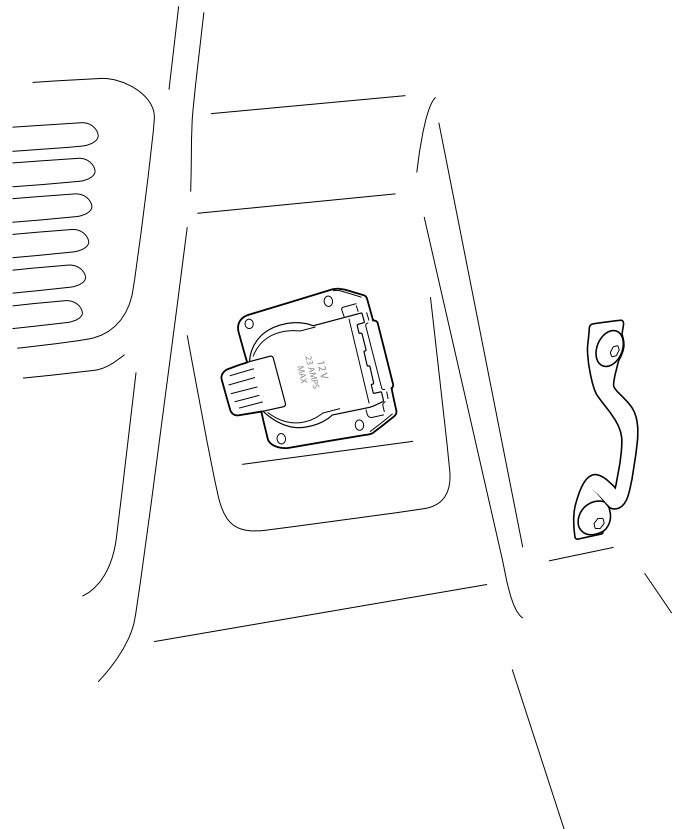

Measure down from top of headboard 220mm & 100mm from inside wall of bed liner as shown. Repeat to the other side.
Using a 50mm hole-saw drill the liner only as indicated.

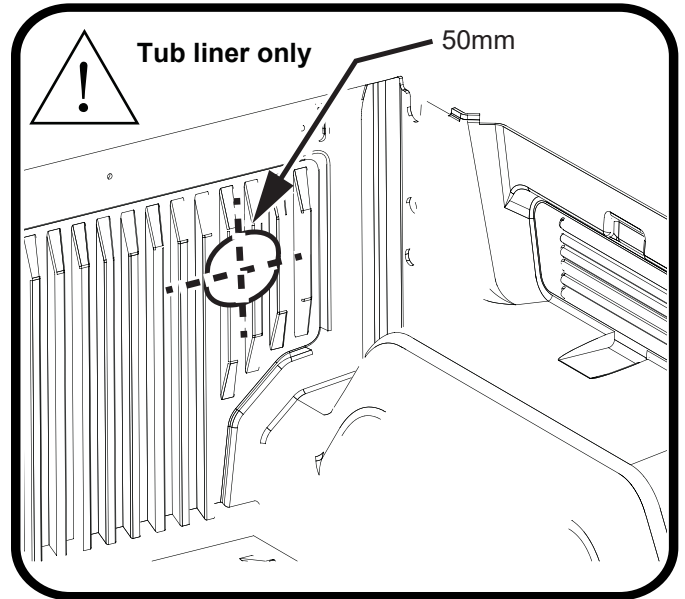
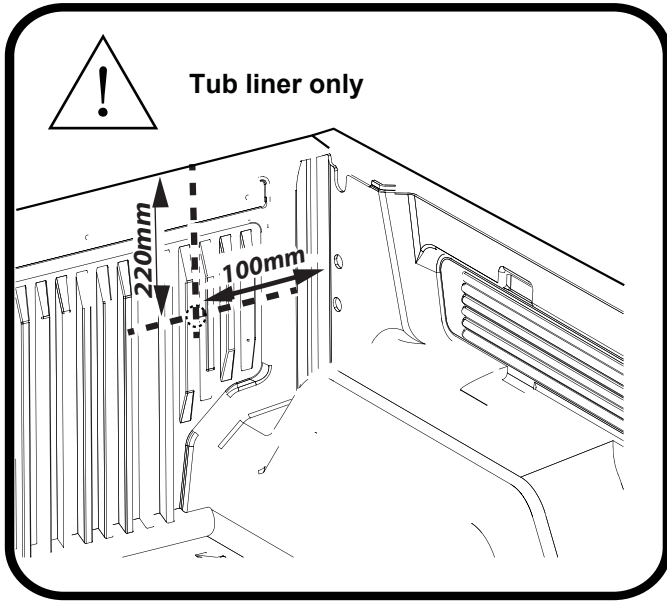
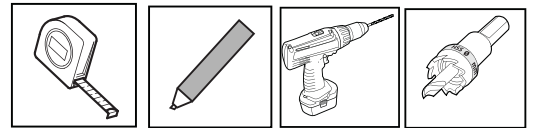

Measure down from top of headboard 230mm & 105mm from inside wall of bed as shown. Repeat to the other side.
Using a 30mm hole-saw drill through tub front panel, file away any sharp edges. Apply anti rust coating. Repeat to other side.

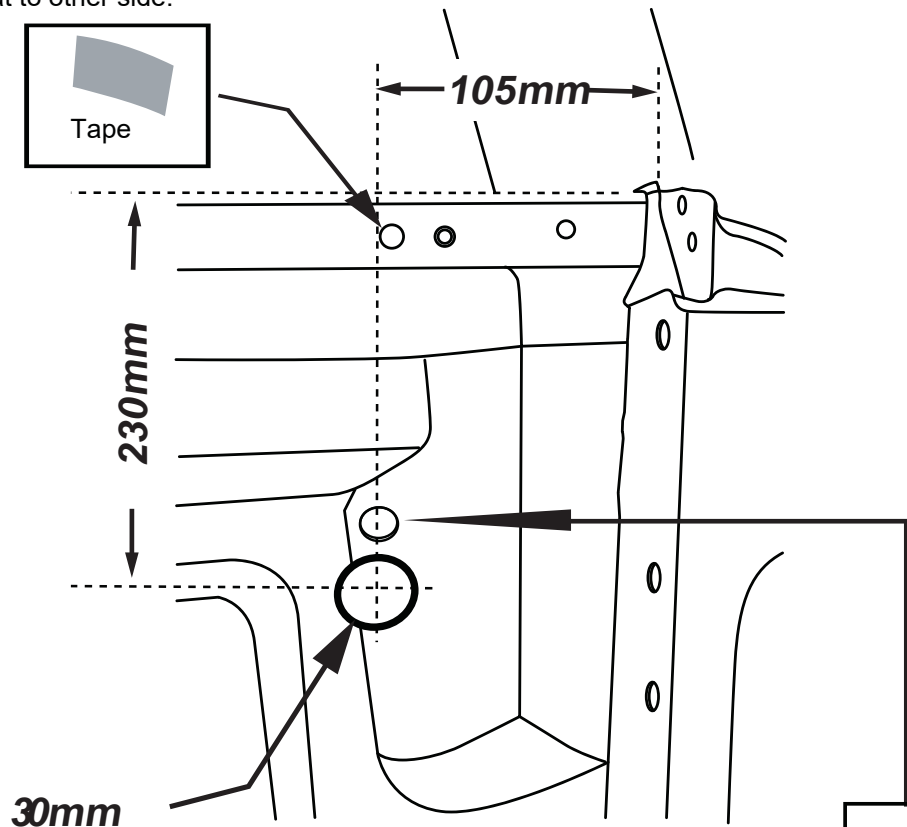
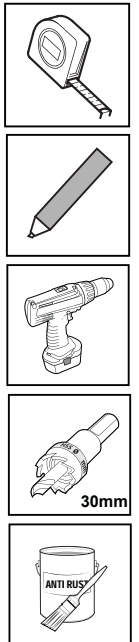

! ATTENTION: Do not exceed 30mm hole.

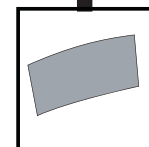

Apply tape provided to seal factory hole. Repeat to other side.

Carefully unpack the box.

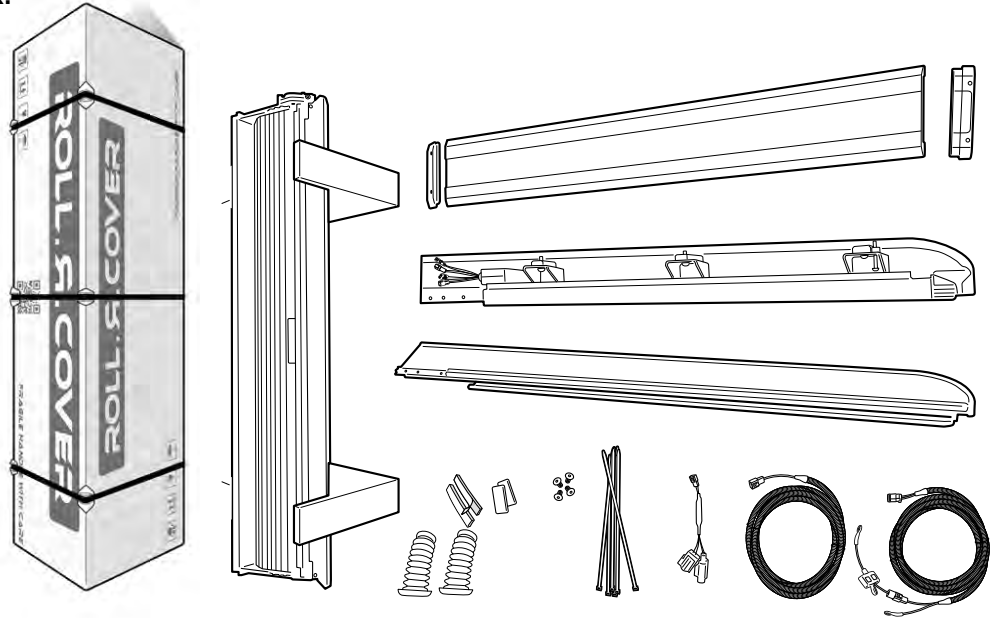

1. Apply 3m primer to the top of head board as indicated.
2. Run foam seal provided along the front (inside edge towards tailgate) of the tub to make head-rail level with sides.

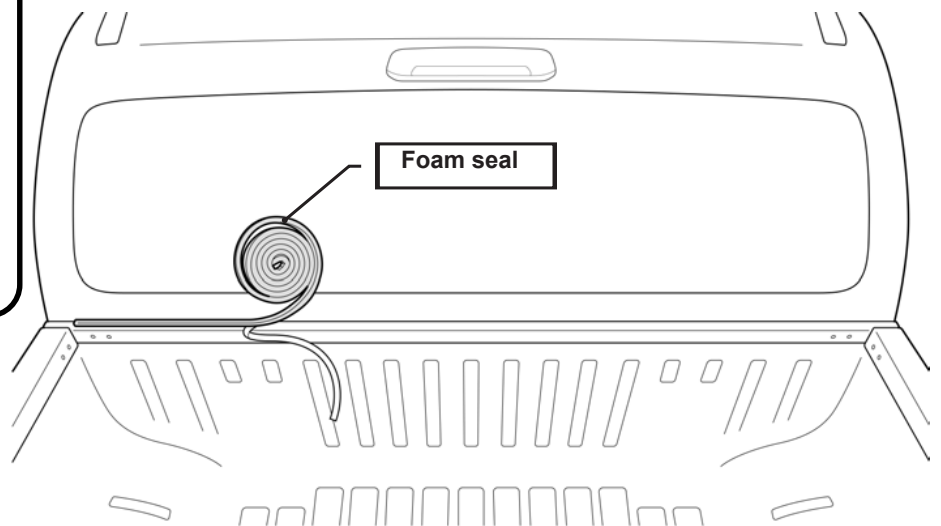
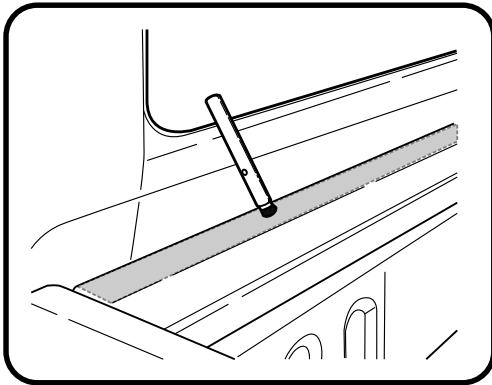

Install front drain pipes (55mm diameter end of hose) through pre-drilled holes on the front tub panel.



Note: With care push tube in.
Taking care pull the tube back so it seals correctly against the front panel of the tub.

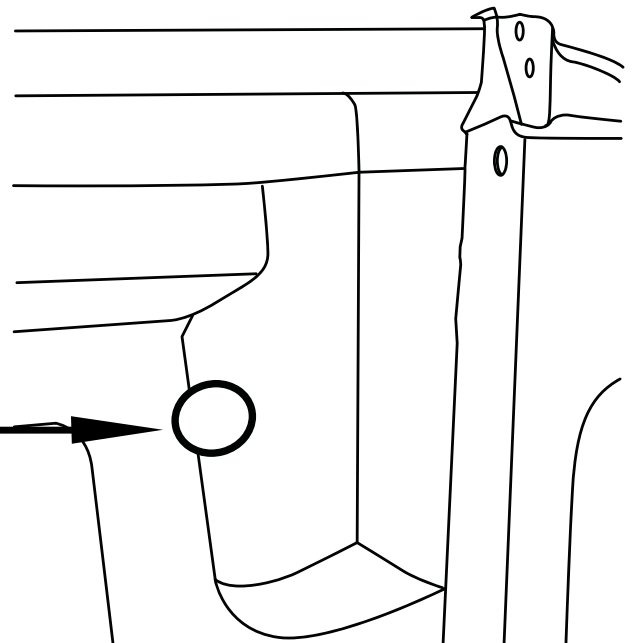
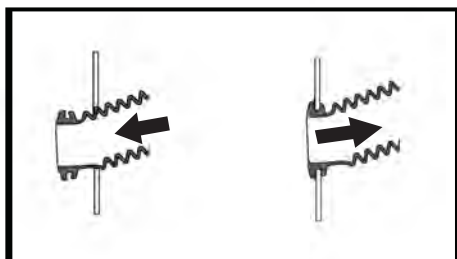

NOTE: Steps on this page are for vehicles fitted with a factory tub liner only. If no tub liner is fitted skip to next page.

Locate the center to the location indicated at the rear of the tub liner.
Use a 15mm hole-saw to drill through the tub liner only, clean edges. Repeat the same steps on the other side.

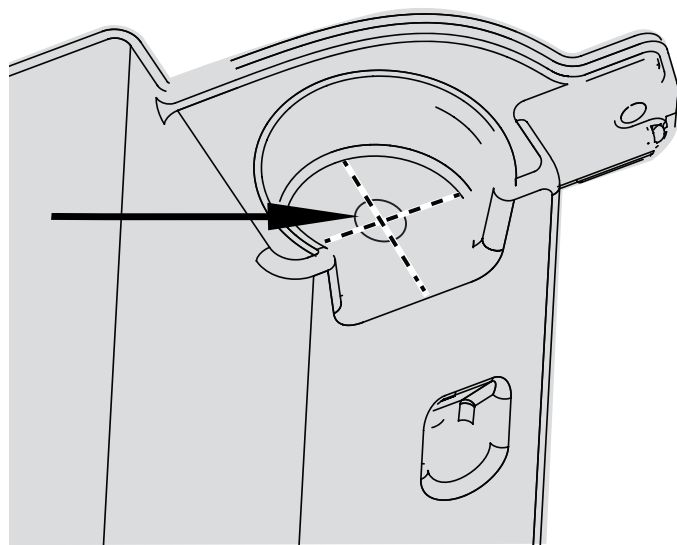
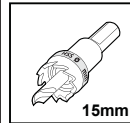
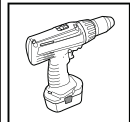
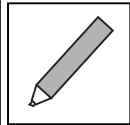
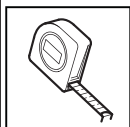

! **ATTENTION:** Do not exceed 15mm hole.

- a** In the specified orientation insert the rear drainage pipe into the previously drilled hole.
- b** Leaving 150mm of the pipe hanging out.
- c** Check the tub liner cavity to ensure there are no obstructions to the drainage pipe. Repeat to the other side.
Re-fit the tail lights.

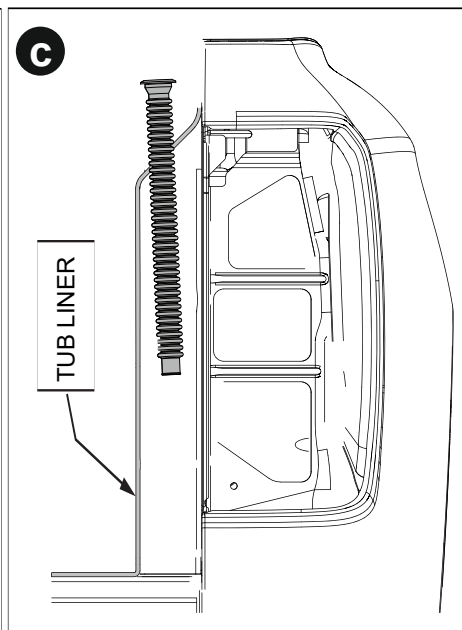
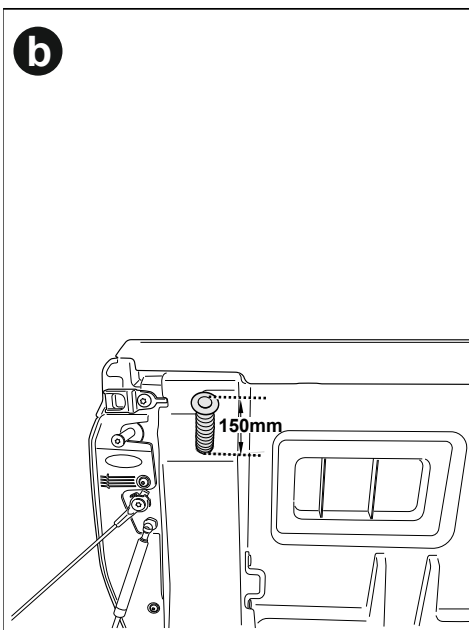
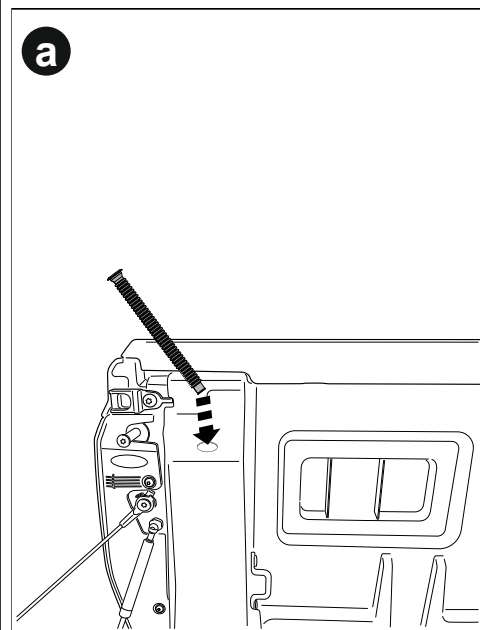

Remove and retain tail lights.

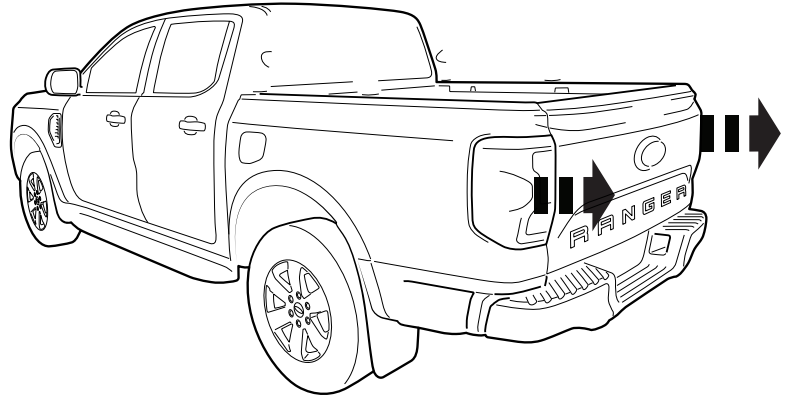

Measure 90mm towards the front of tub from the center of the indicated factory M6 thread. Measure down 100mm from the top edge of the tub as directed and make a mark.

Use a 15mm hole-saw to drill through the tub pillar, and file away any sharp edges. Apply an anti-rust coating. Repeat the same steps on the other side.

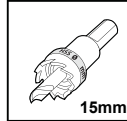
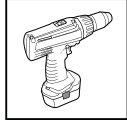
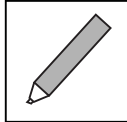
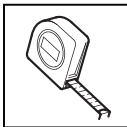

ATTENTION: Do not exceed 15mm hole.

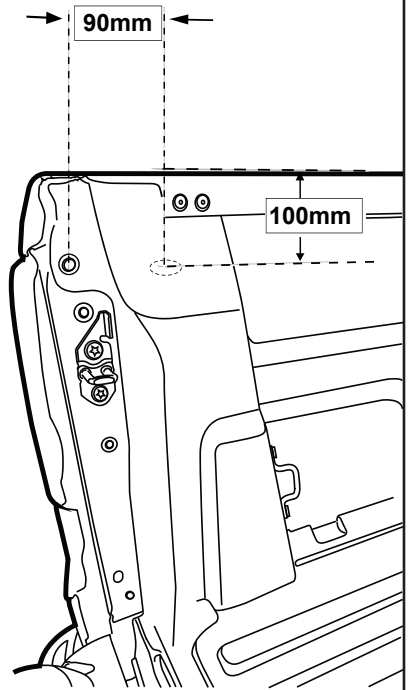

- a** In the specified orientation insert the rear drainage pipe into the previously drilled hole.
 - b** Leaving 150mm of the pipe hanging out.
 - c** Check the tail light cavity to ensure there are no obstructions to the drainage pipe. Repeat to the other side.
- Re-fit the tail lights.

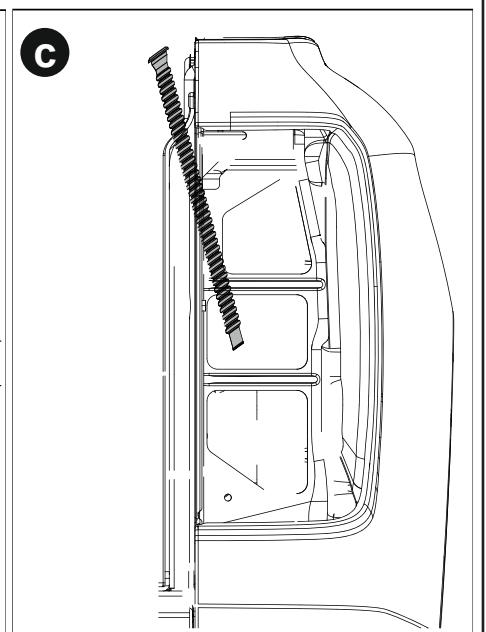
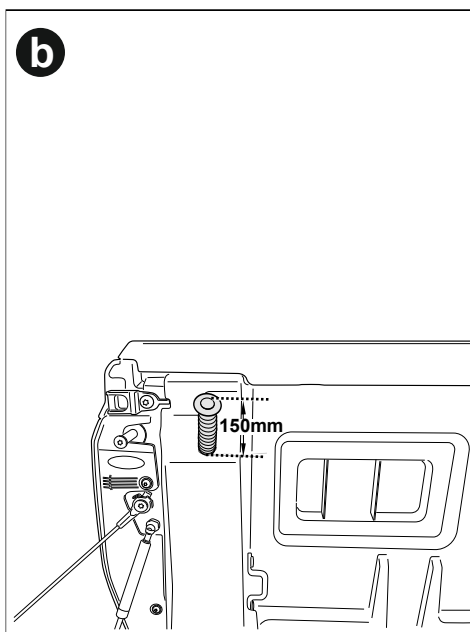
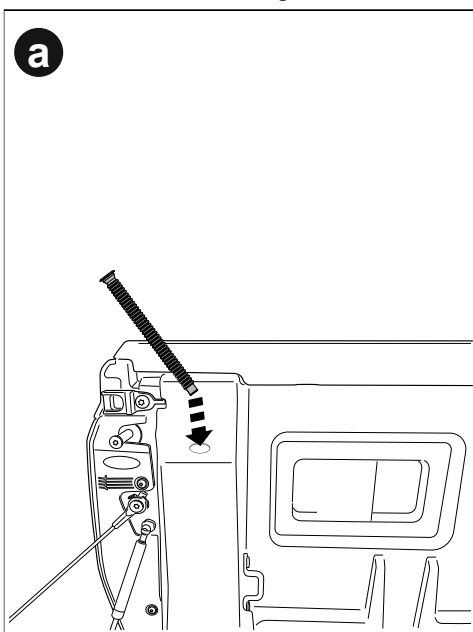

Disconnect fuse patch from battery loom S2.75.

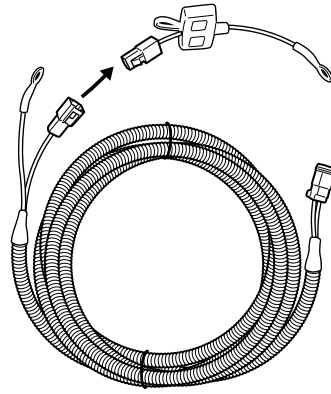

Wiring Harness steps

1 Feed Battery Loom S2.75 through the cavity

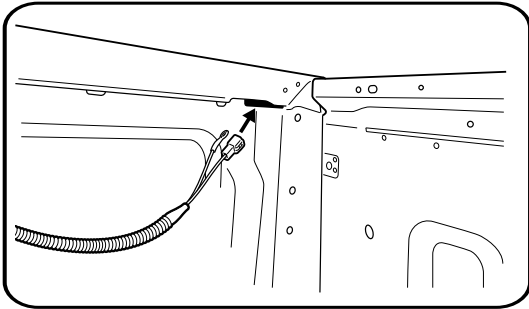

3

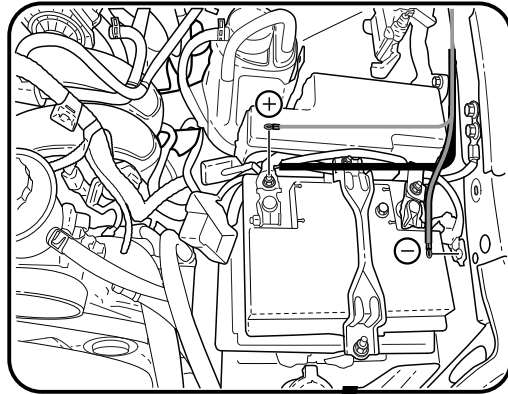

2

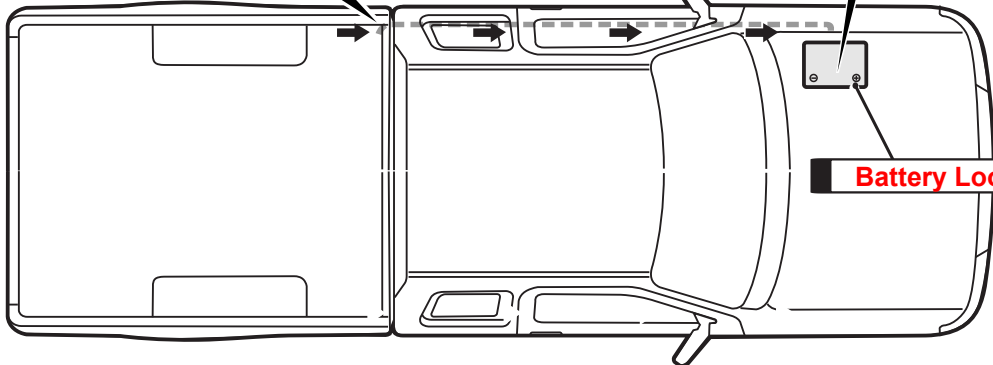

Run the wiring from the front corner cavity (leaving 200mm in the tub) to the battery over the chassis rail. Making sure to keep away from hot obstructions and cable tie every 400mm. Reconnect fuse patch to battery loom S2.75, now attach fuse patch to positive of battery and earth to the body of the Ute.

Feed CL-Short-Loom through the cavity.

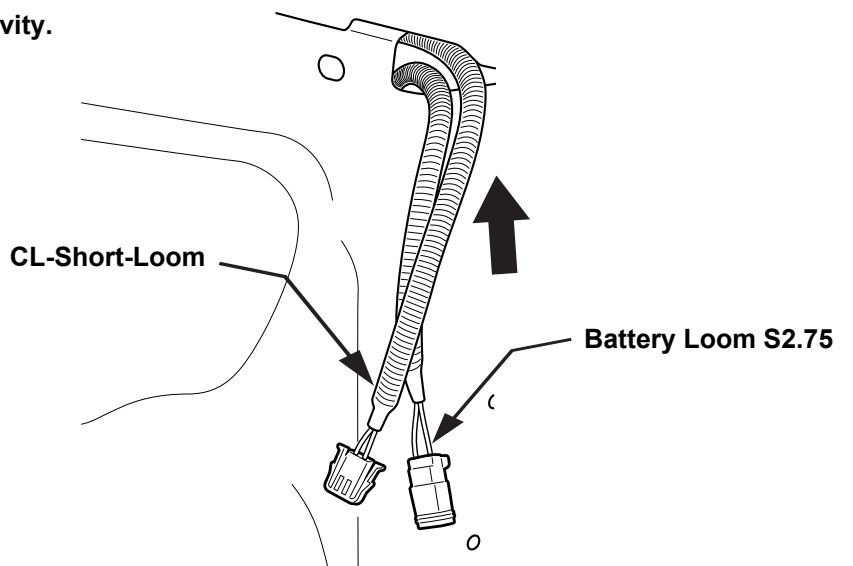

Remove required clips to gain access to wheel arch inner.

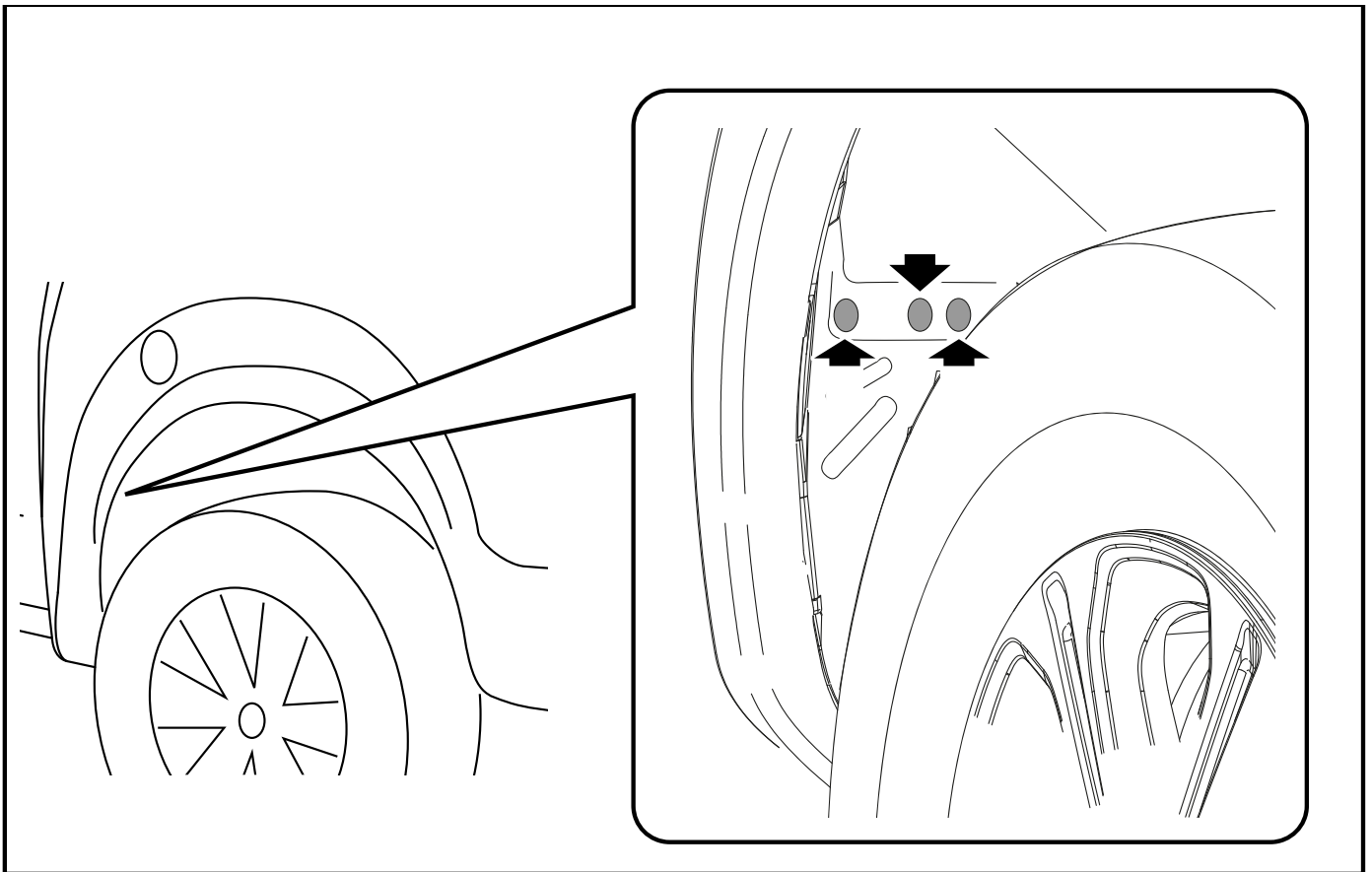

Disconnect the fuel flap connector . Patch the shorter (two grey connectors) between the two fuel flap connectors using P-Patch-K. Use one zip tie to secure the harness to the existing harness.

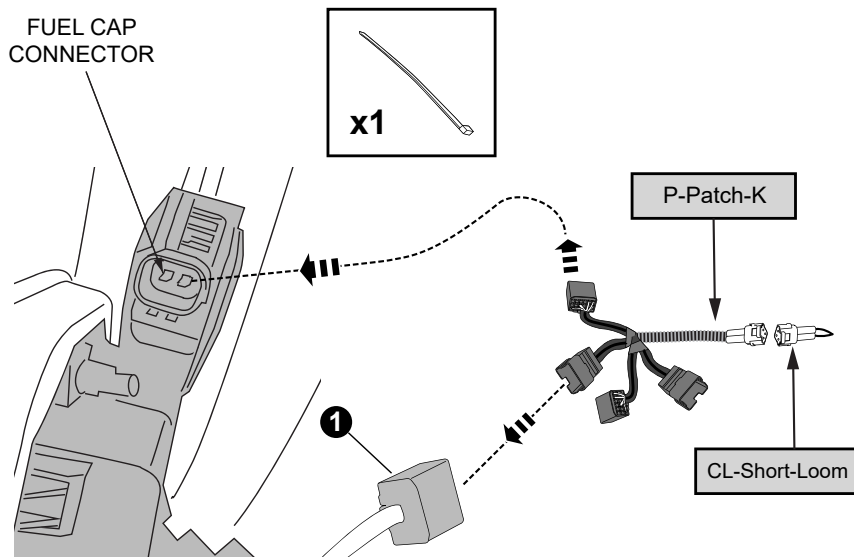

Now connect CL-Short-Loom to P-Patch-K. Zip tie any loose loom within wheel arch.



NOTE: P-Patch-K has 2 variants connectors, one is to suit the Ranger Raptor, the other is to suit the standard Ford Ranger T6. The un-used plugs can be connected to each other.



keep the cannister in the foam blocks from the packaging for assembly.

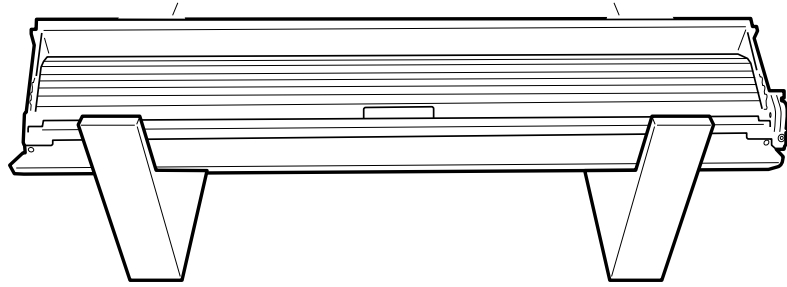

With assistance turn the canister on its back on the foam blocks.

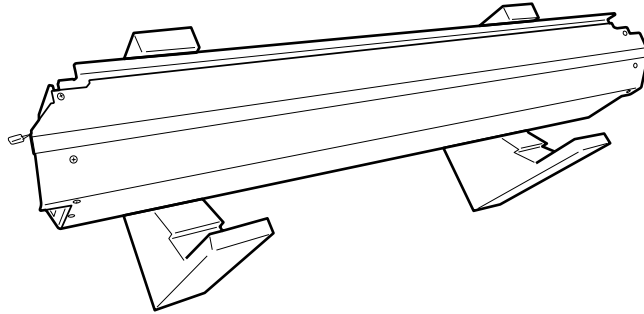

Disengage motor from the axle by unfastening the 3 Screws as indicated. Retain all parts.

Remove and retain the 3 screw from the canister as indicated.

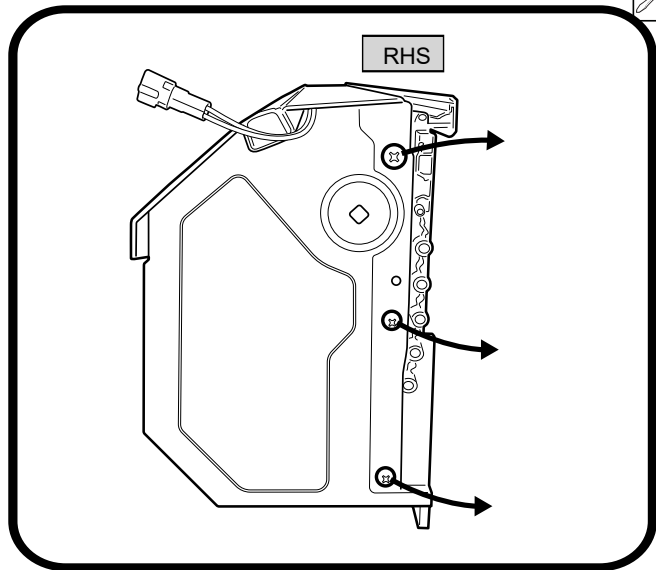
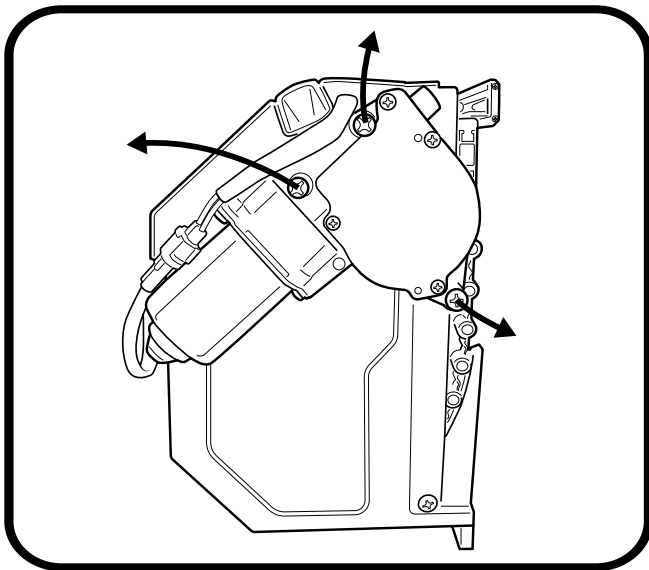

Now on the other side, remove and retain the 4 screws from the canister as indicated.

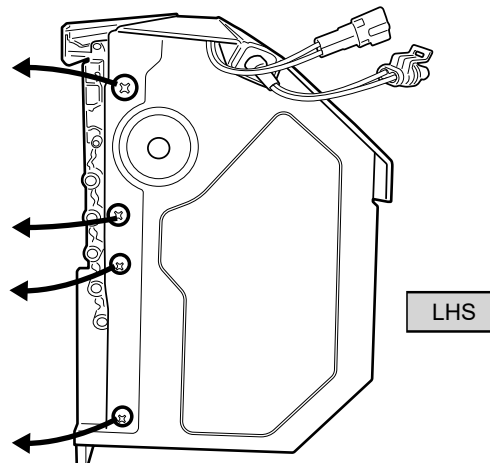
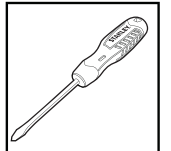



Important Note: Ensure that the Z seal within the track is positioned over the curtain and not folded inward. **WARRANTY** voided if assembled incorrectly.

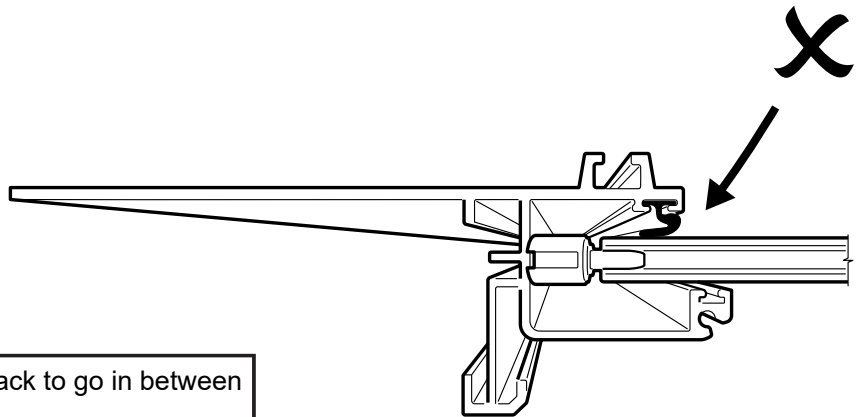
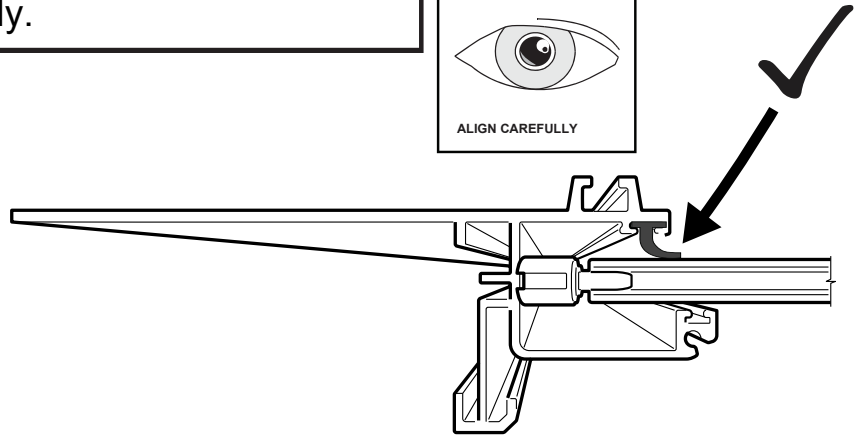
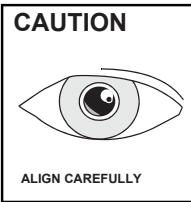

Align side rail to side of canister, guide the track to go in between the curtain end rubber stop.

NOTE: LHS side rail to be assembled first.

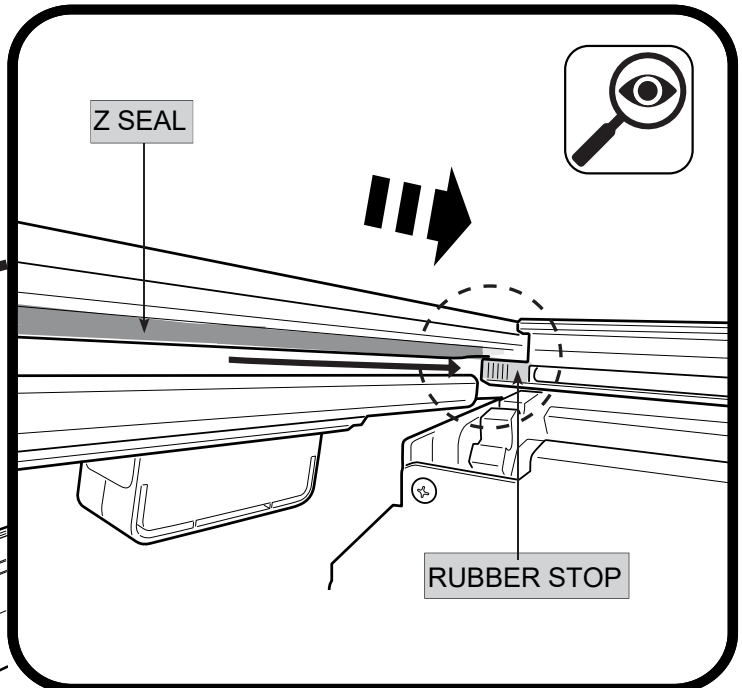
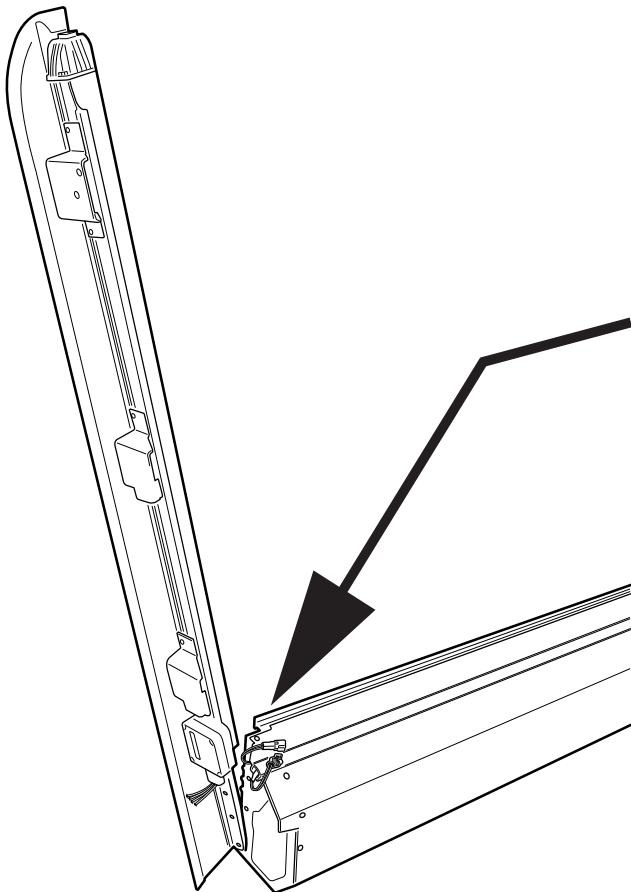

1. Using the retained screws, spring washer and washer, Loosely fasten the side rail to the location indicated.
2. Side rail edge must compress and meet with the canister profile as indicated below.
3. Fasten all screws tight.

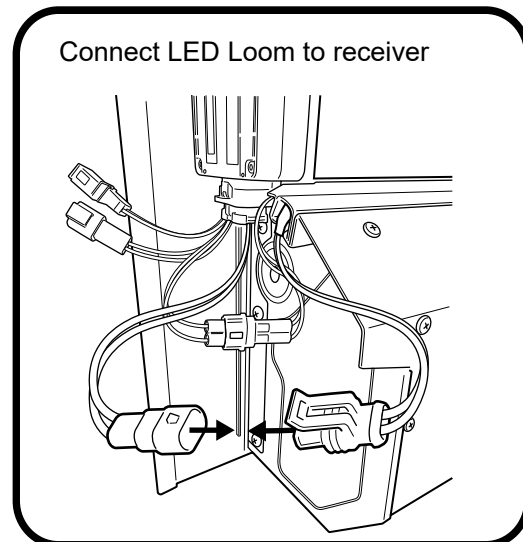
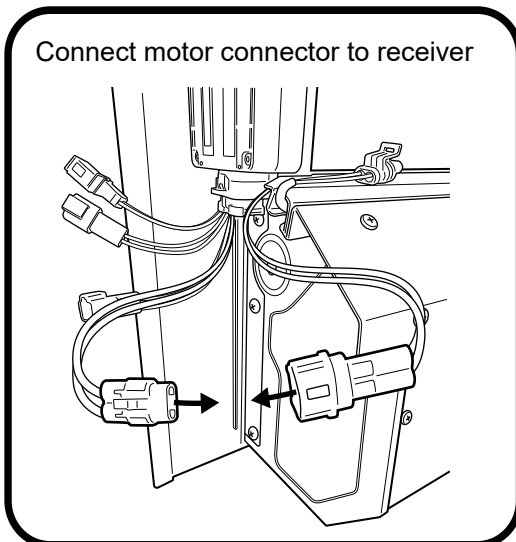
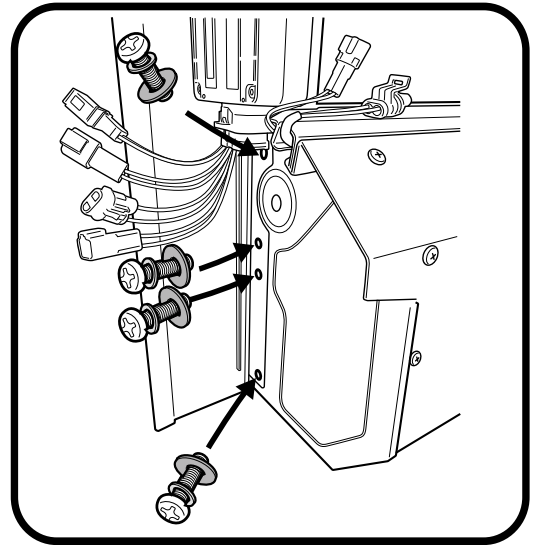
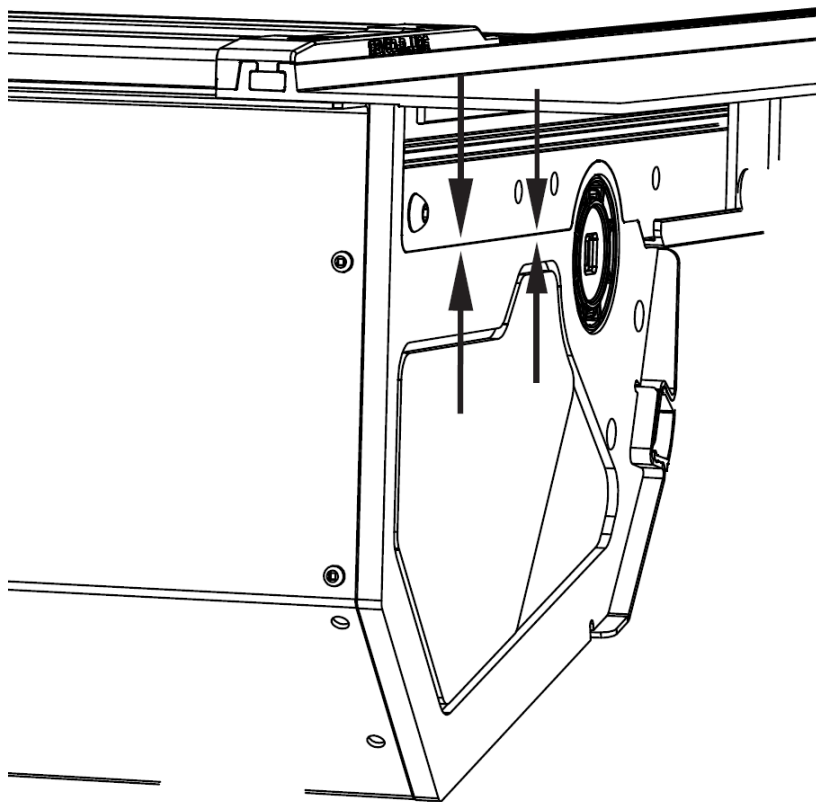
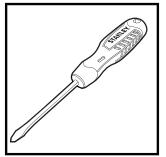



Important Note: Ensure that the Z seal within the track is positioned over the curtain and not folded inward. **WARRANTY** voided if assembled incorrectly.

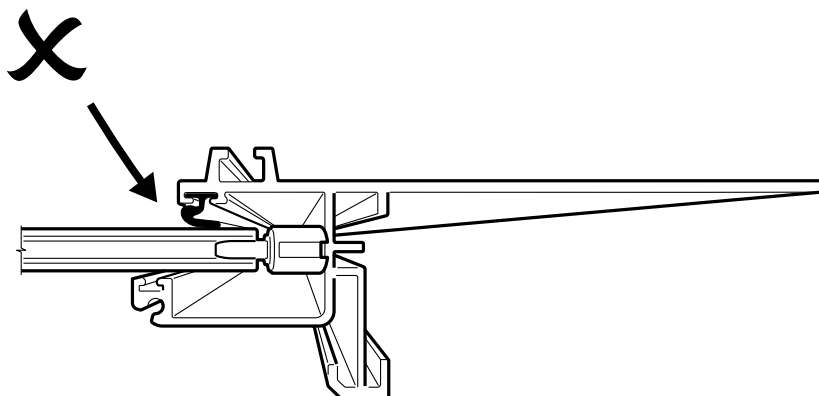
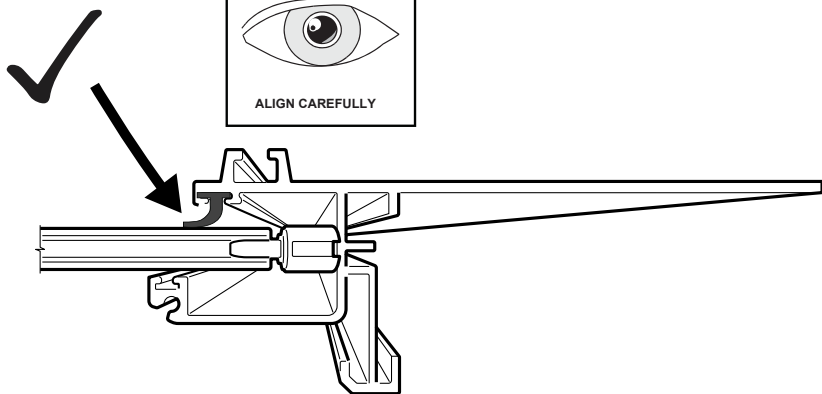
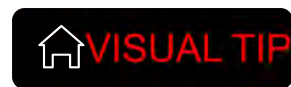

Align side rail to side of canister, guide the track to go in between the curtain end rubber stop.

NOTE: LHS side rail to be assembled first.

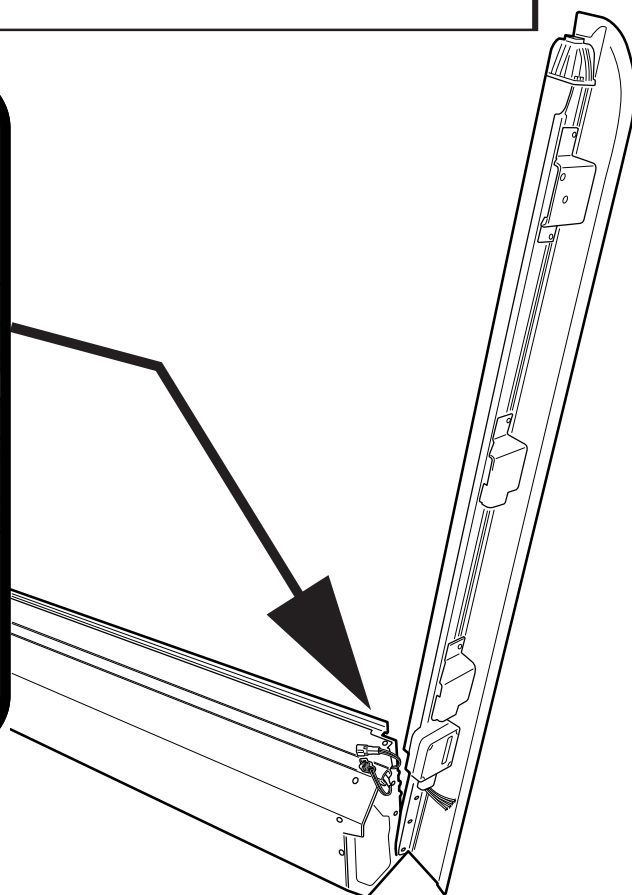
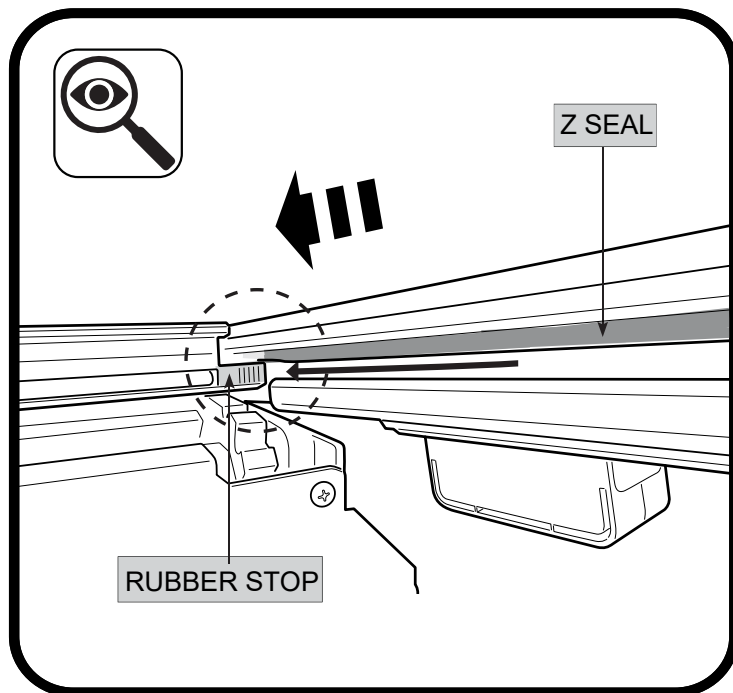

1. Using the retained screws, spring washer and washer, Loosely fasten the side rail to the location indicated.
2. Side rail edge must compress and meet with the canister profile as indicated below.
3. Fasten all screws tight.

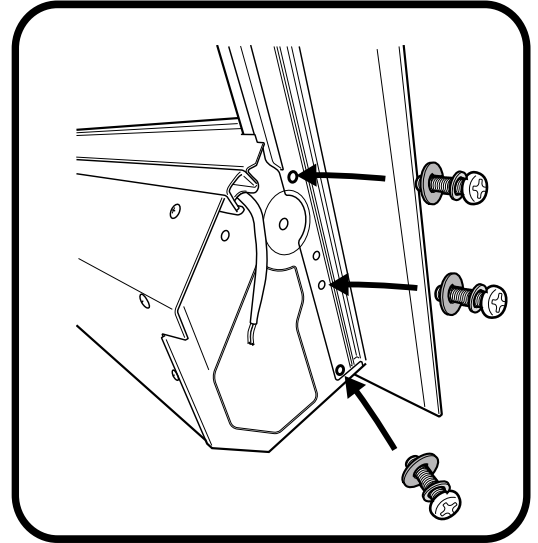
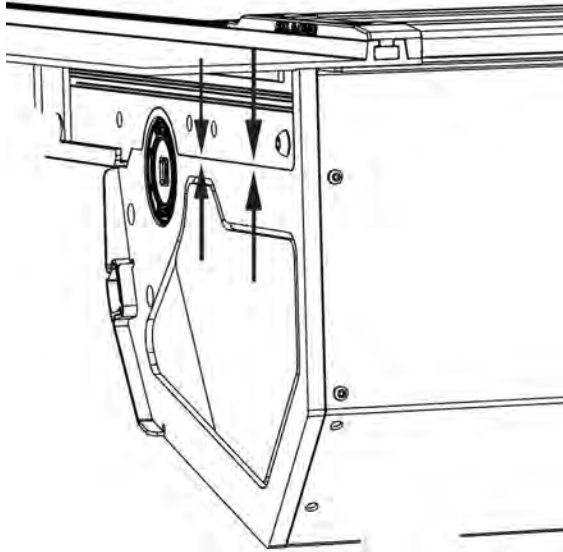
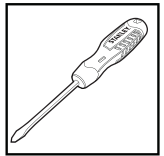

Feed M6 bolt through spring washer, motor and rubber bush.

NOTE: Rubber bush orientation has to be as per image. (side with text on rubber, to face the motor).

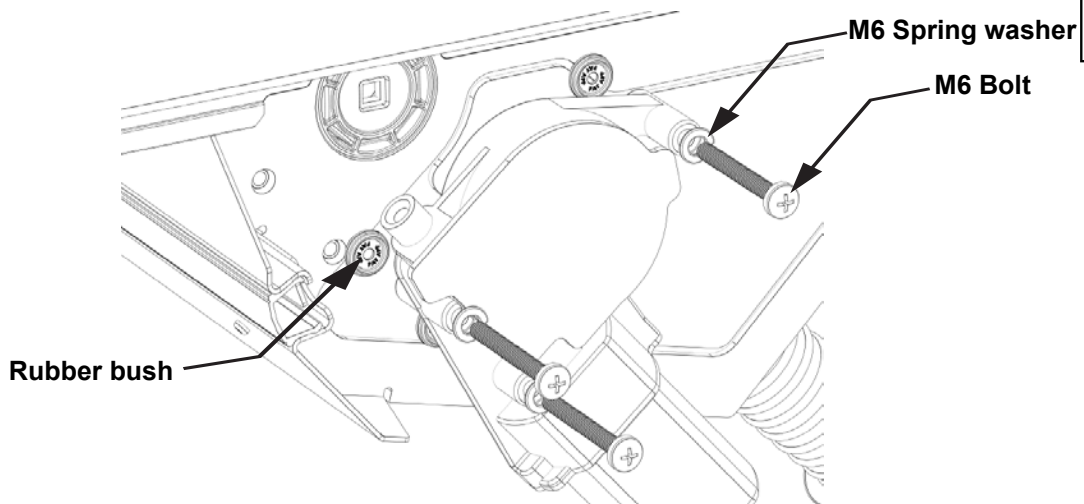
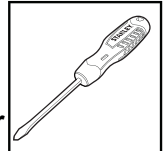

Align & insert motor shaft to axle.

NOTE: Pull / push curtain for axle to rotate.

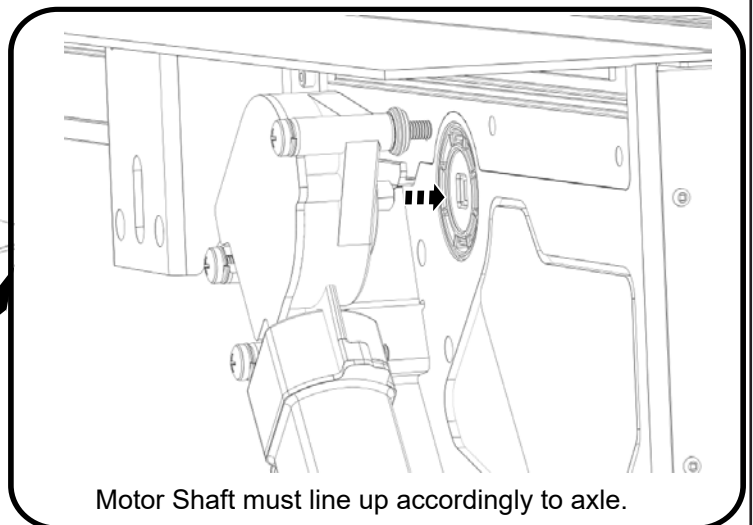
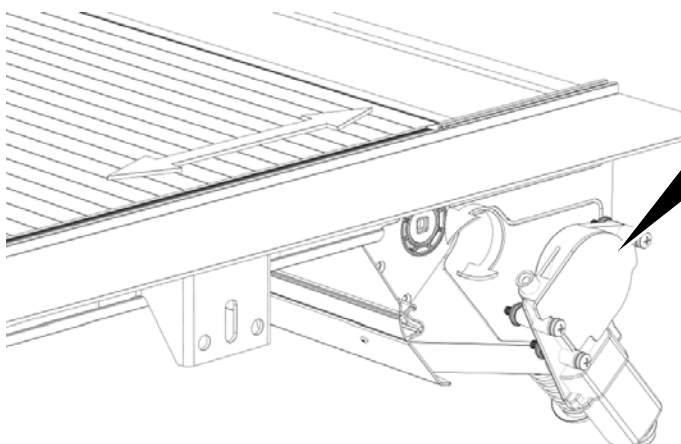

Motor Shaft must line up accordingly to axle.

Fasten all 3 screws to 2nm torque. Over tensioning will cause operating issue's.

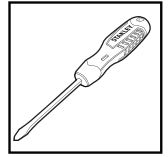
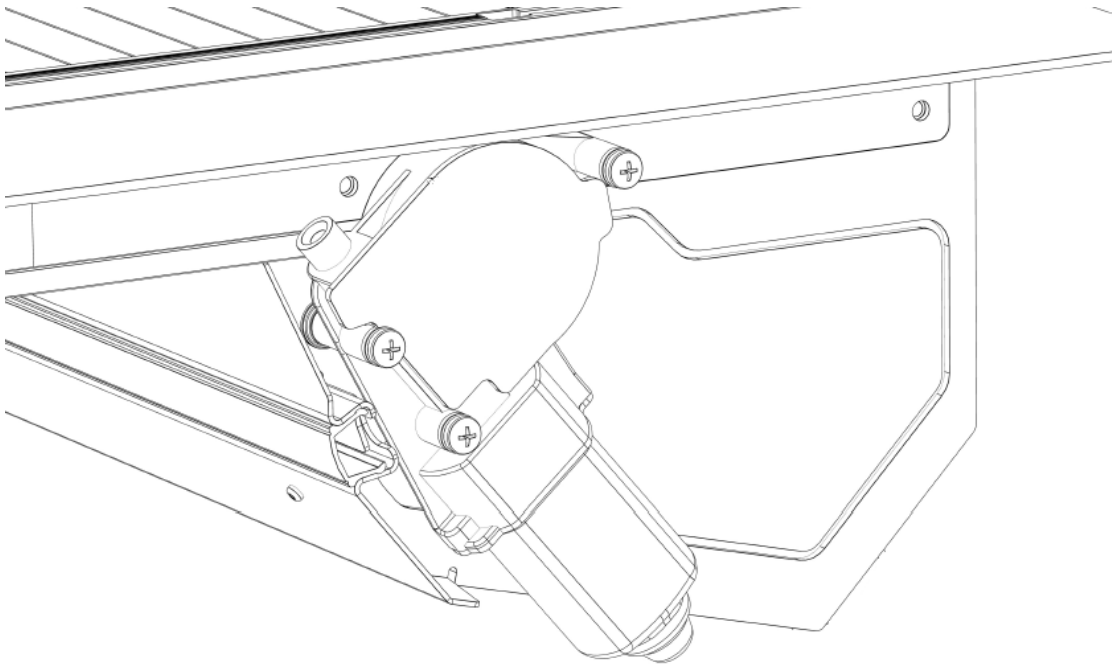

Motor is to sit level.

Any obstructions between motor and canister may cause operating issues.

Apply D-sponge foam tape to side rail as indicated. NOTE: Join foam firmly to the per-fitted foam of the canister. Carefully trim excess off & discard as indicated. Repeat on the other side.

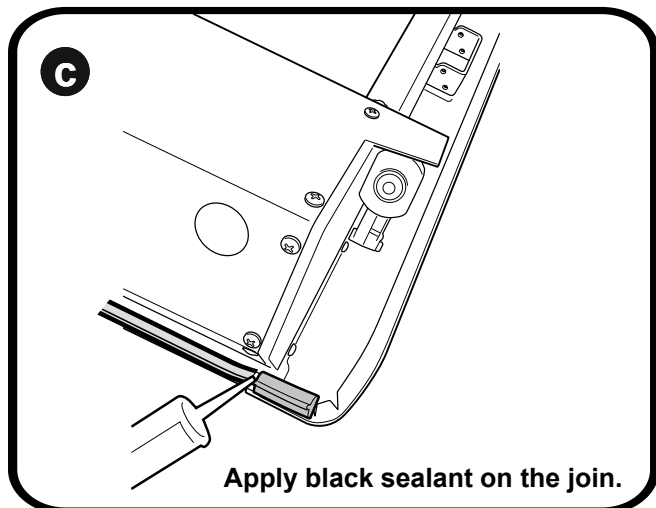
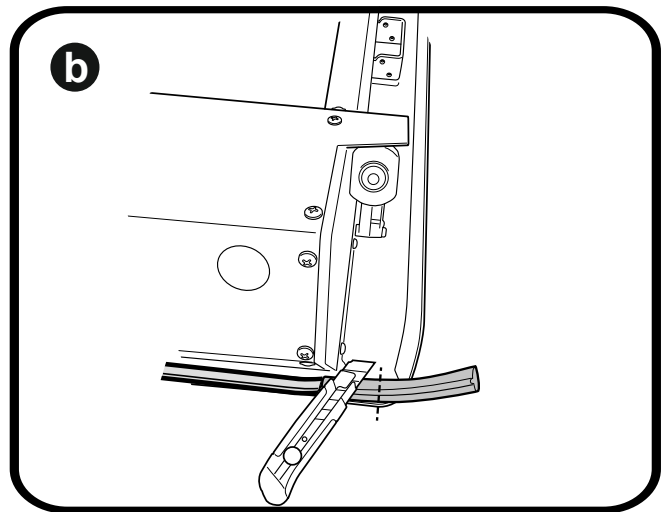
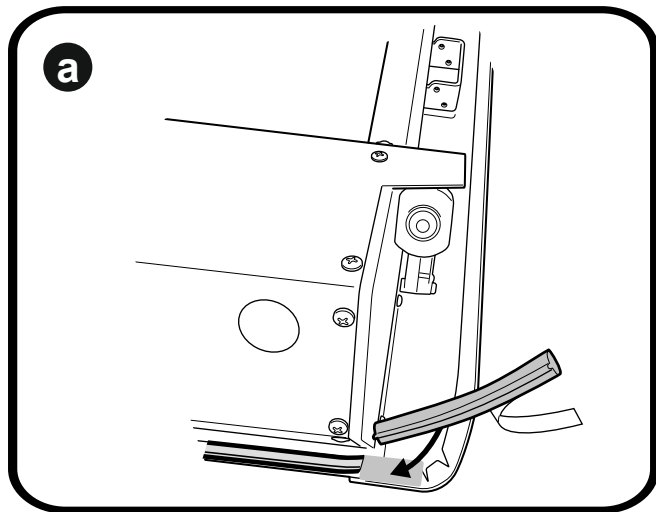

Apply black sealant on the join.

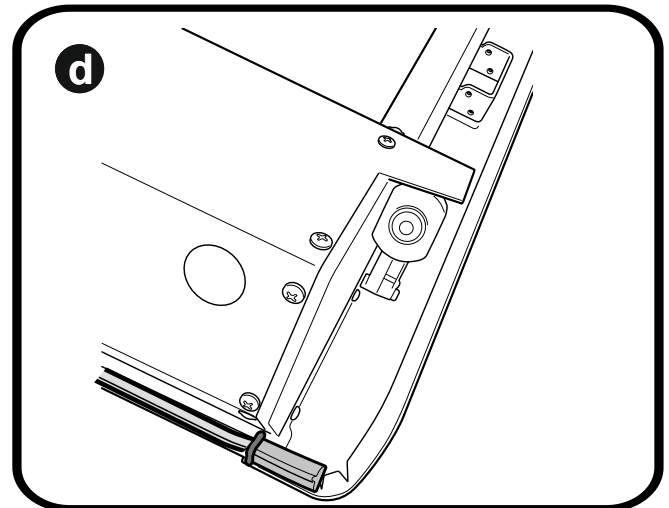

Carefully bring down the assembled unit.

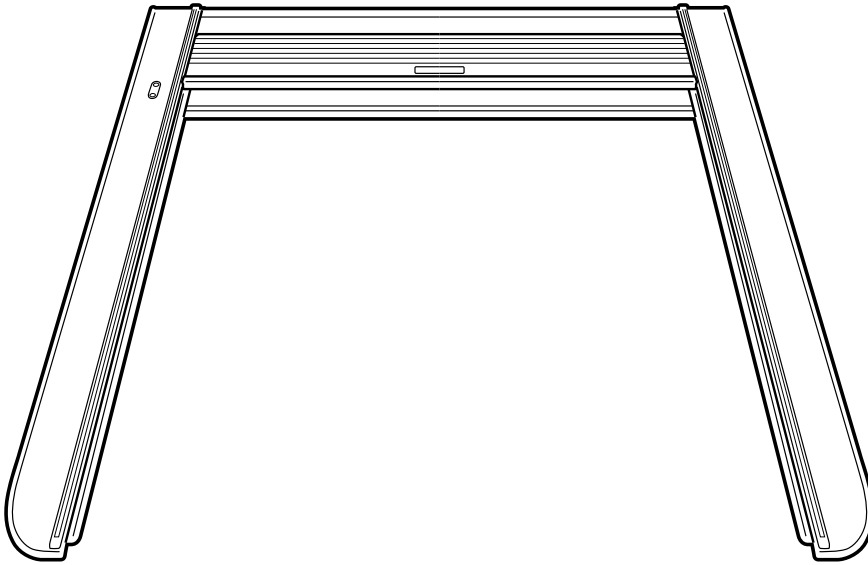

Insert side end caps to the top cover.

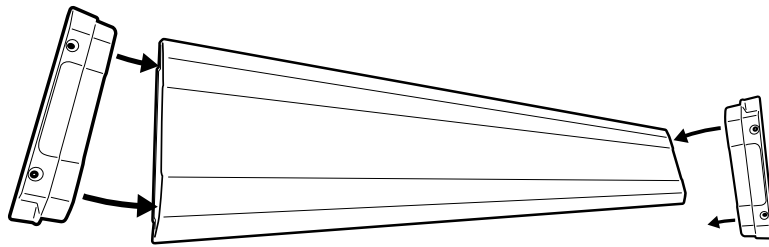

Place & Align top cover over the canister and side rails.

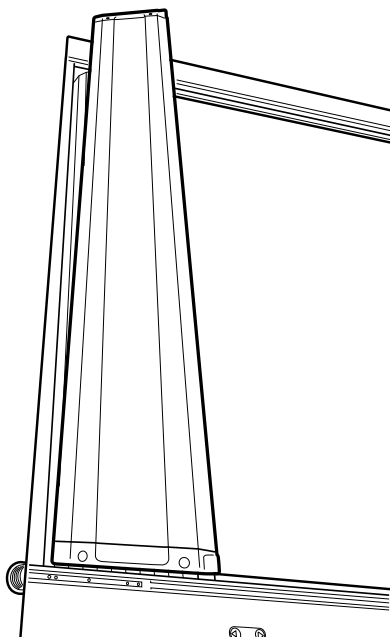

Using countersunk screws provided, line up end cap holes to the threads on the side rail. Fasten to 3nm torque. Repeat to the other side.

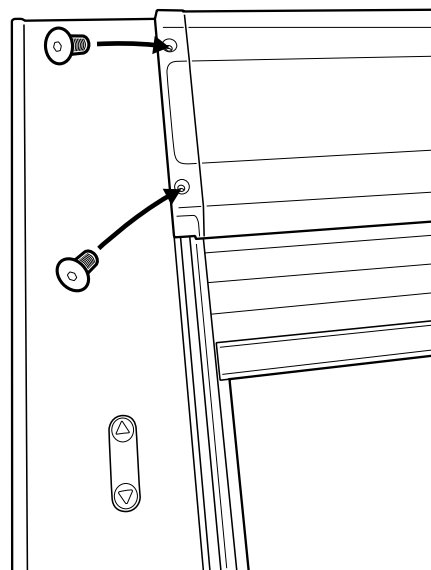

Seal any exposed gaps or holes on the front panel of the Ute bed with sealant.

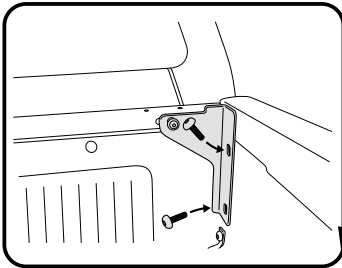
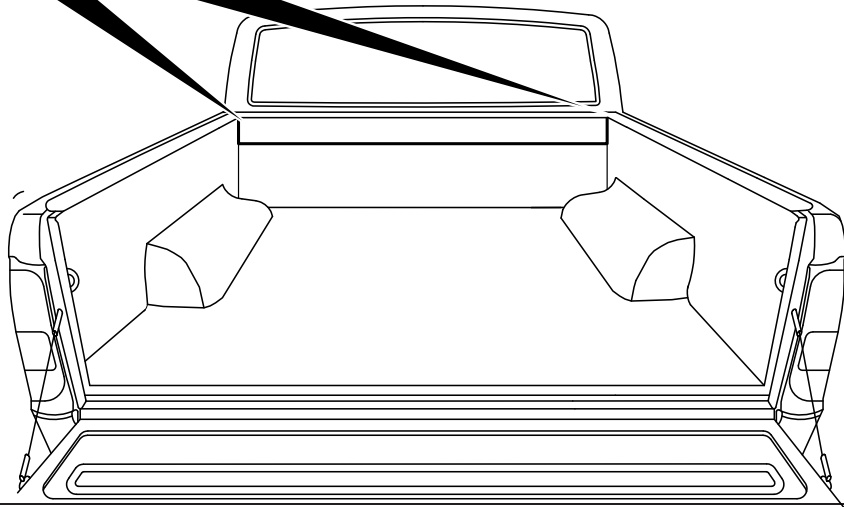
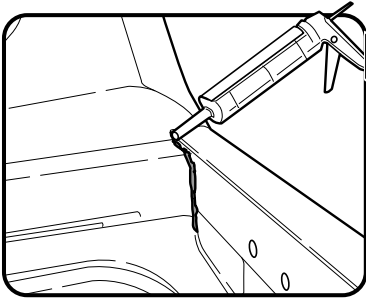
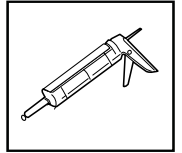

Attach the right angle bracket provided loosley with the retained factory bolts to the left and right top corners of the tub.

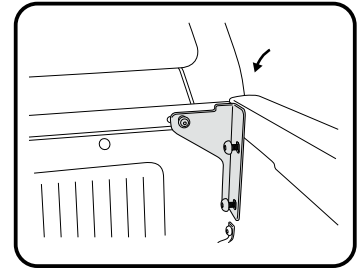
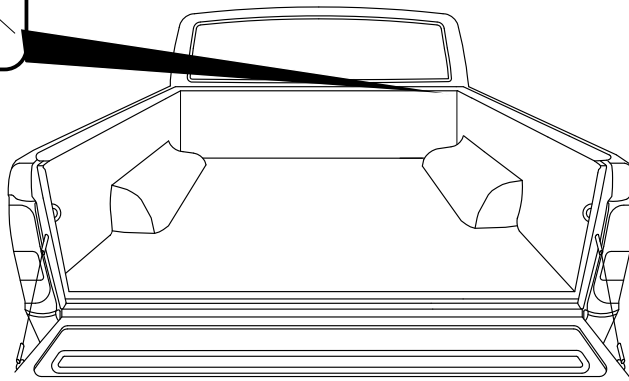

Push the brackets all the way down. Then tighten all bolts to 6nm to avoid the bracket from moving.

NOTE: If your vehicle does not come with the factory bolts, use the M8x25mm & M6x20mm provided in the kit.

Place the Roll-R-Cover unit on to Ute bed.

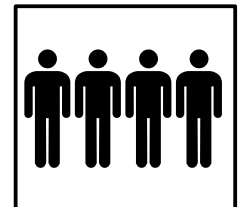
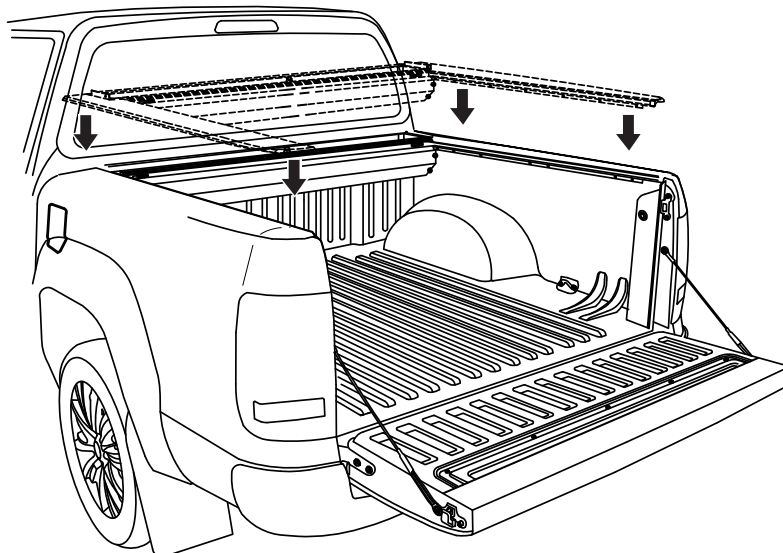

4 People
Recommended for lift

With care, pull out any side rubber that has folded under the side rail.

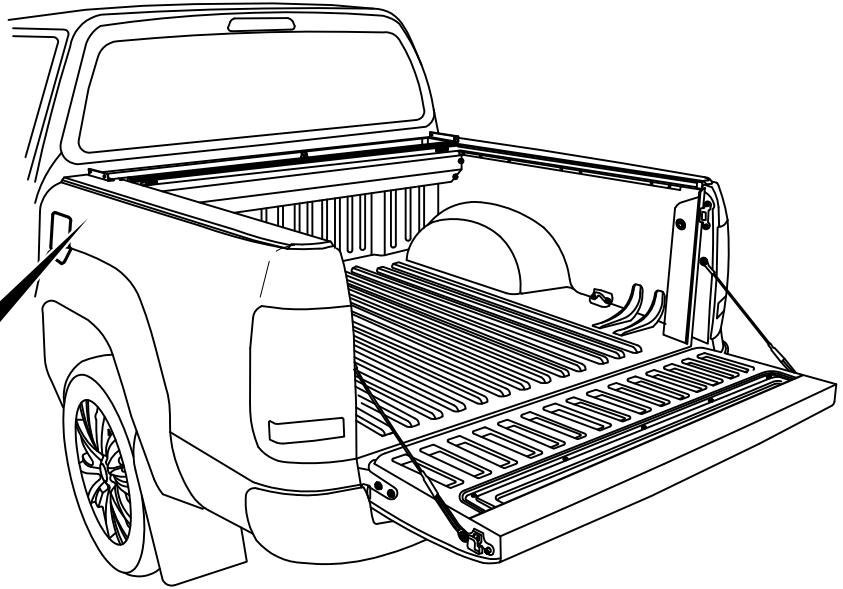
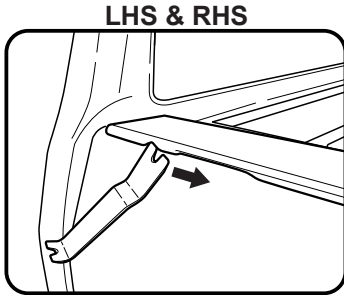

With the tailgate up (Closed position), Pull left & right hand side rails towards the tailgate, stopping short by 5mm between tailgate and side-rail endcap.

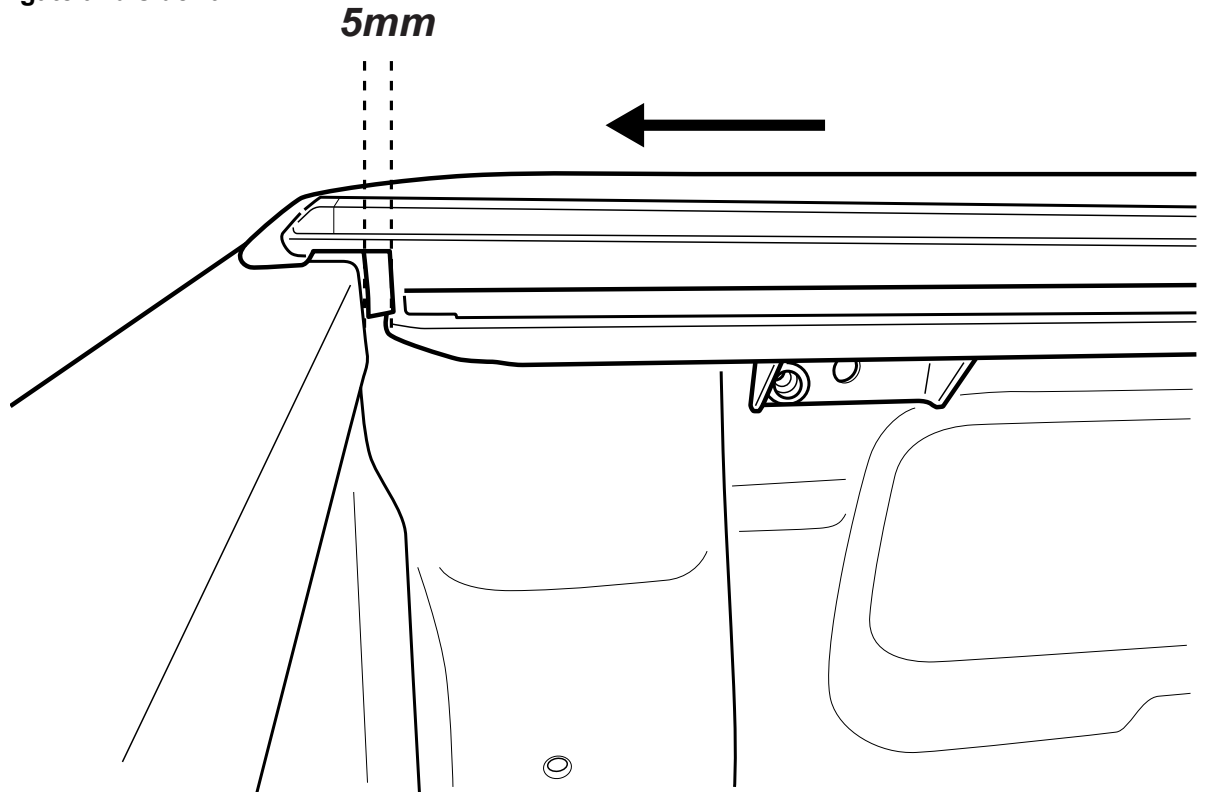

Foam compressed to 5mm when tailgate is closed.

Gap between tailgate and side-rail end cap to be 5mm.

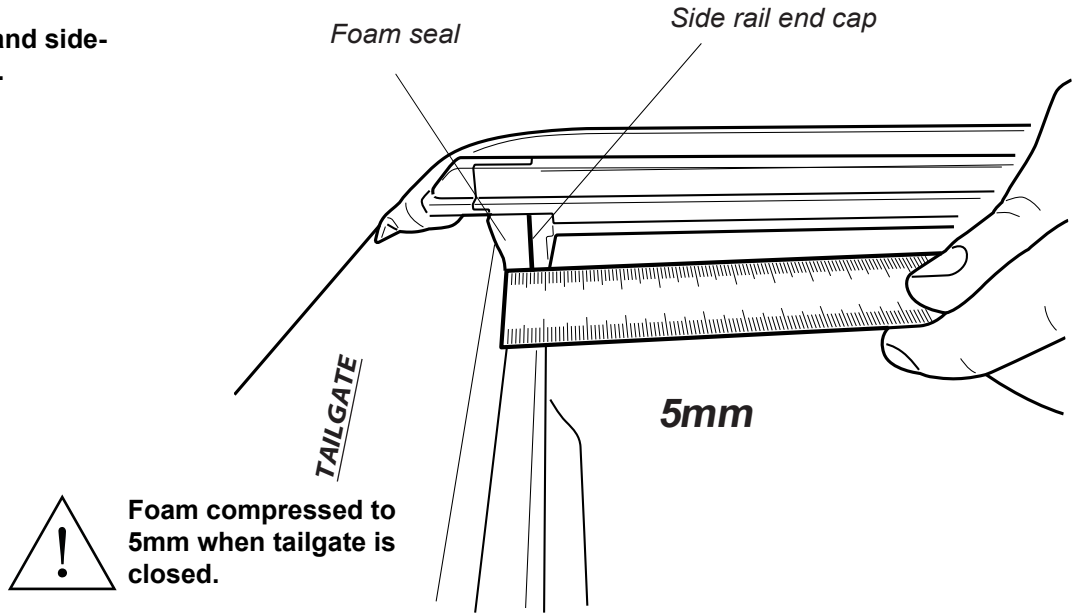

Position clamp behind the inner top lip of the bed rail and the **center elongated** hole of the side rail mounting brackets. Repeat to all 6 positions.

Ensure the M8 nut is in the indicated slot of the clamp

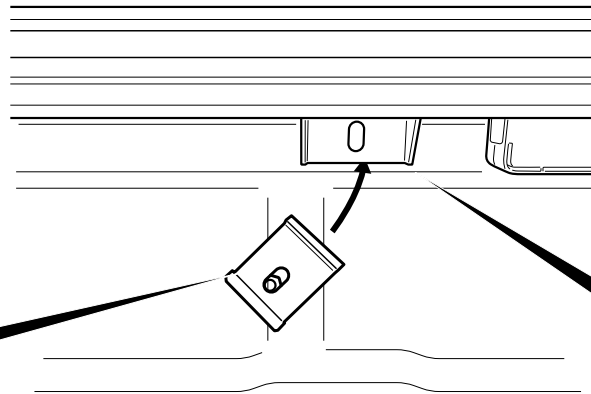
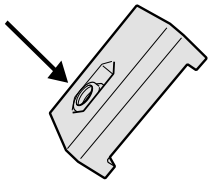

Fasten clamp loosely into position using M8 washer, M8 spring washer and M8 x 35mm bolt.

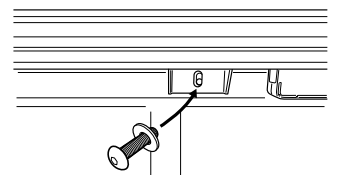

1. Apply downward pressure on side rails.
2. Lift **clamp** all the way up or as far up as possible then fasten clamp to 14Nm torque in the order indicated below.

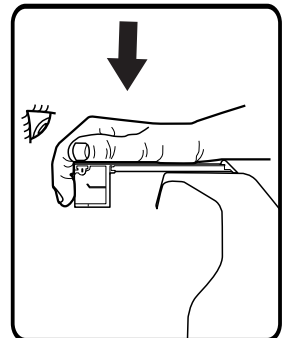
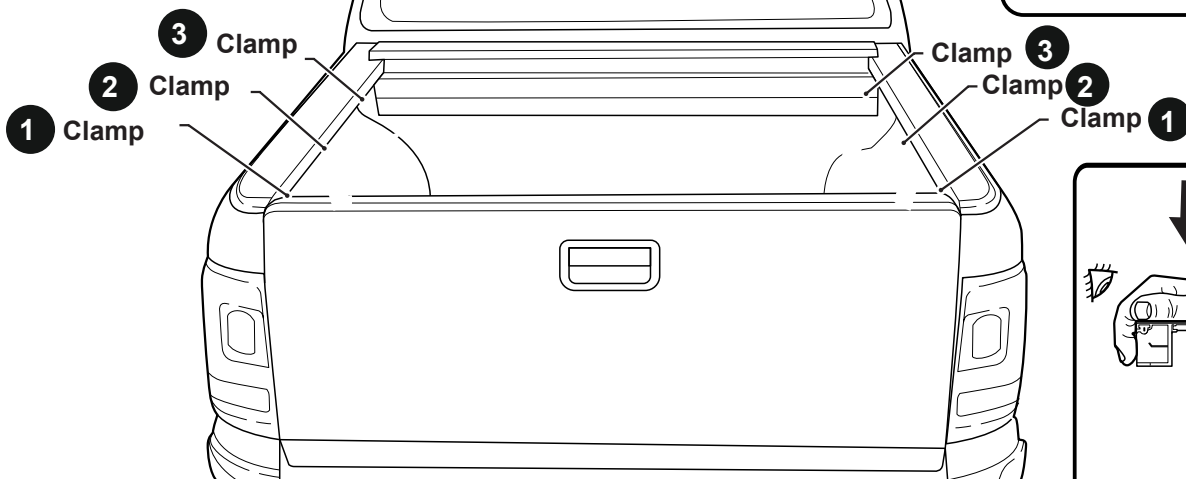
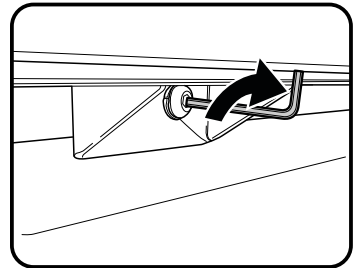

Apply flat plate behind adjusting bolt hole to the ute bed panel or to the liner if the Ute is equipped with a tub liner.

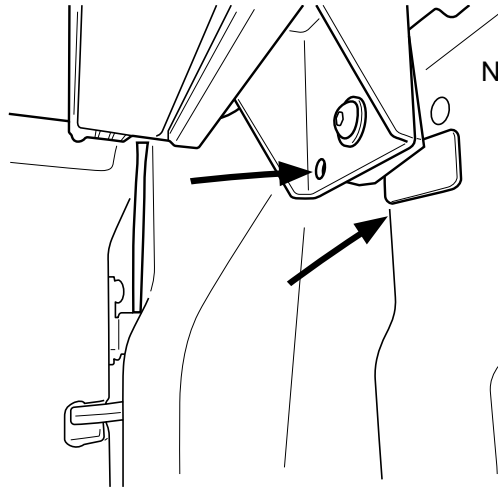

Note: Rear Clamp bracket.



Note: Clean surface before applying flat plate.

Feed M8 nut into M8x70mm bolt and through clamp bracket's pre-installed nutsurt as indicated.

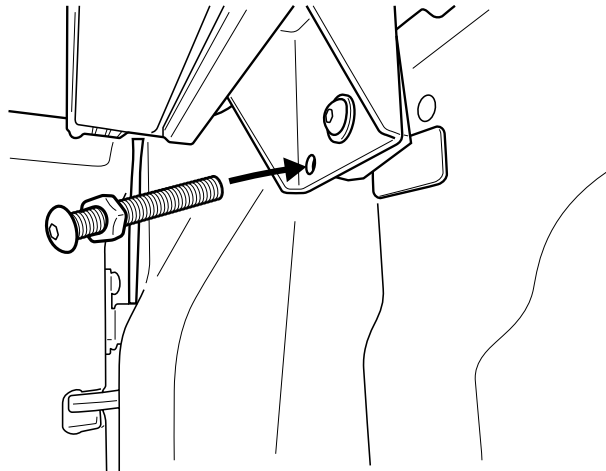

Side rail rubber to sit 1mm below from the top of the tailgate in the closed position.

A large diagram with rounded corners showing the side rail rubber adjustment process. It includes a side view of the tailgate and side rail, a top-down view of the tailgate, and a small inset diagram showing the adjustment bolt being driven in or out. A line connects the inset to a small drawing of a ute with its tailgate open.

1mm below

1mm below

Seal will touch when closing tailgate.

Seal tucked to inside lip of tailgate.

Drive the adjustment bolt in or out, to lift or lower the rear of the side rail till it sits 1mm below the top of tailgate.

Fasten the M8 nut against clamp bracket.

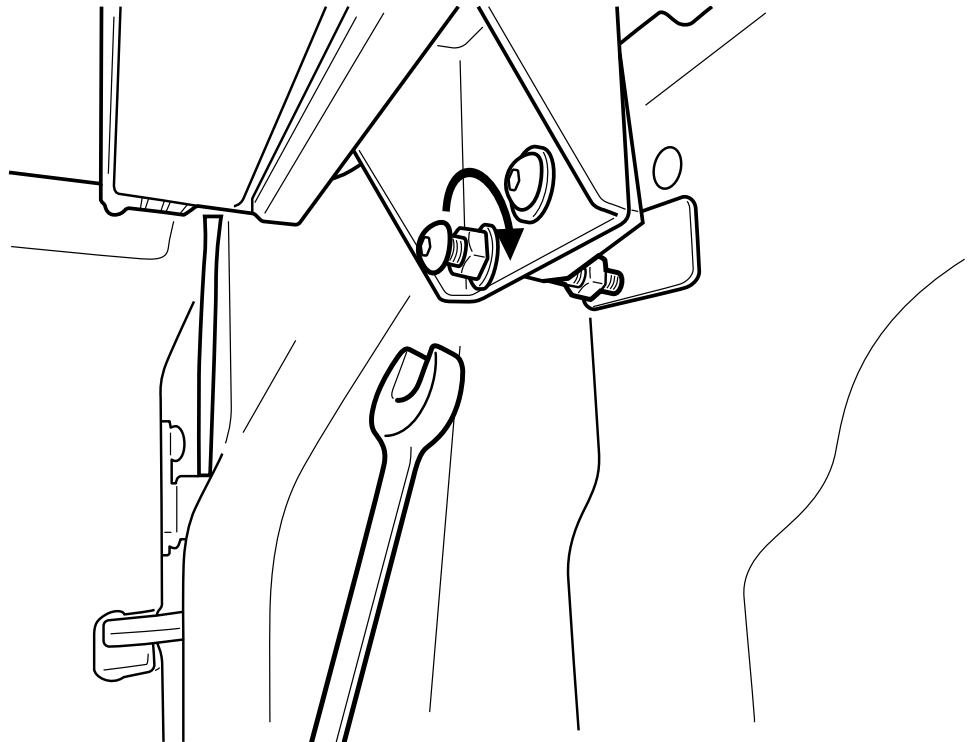

1. Clean area with non oil based cleaner, ie alcohol wipe.
2. Apply clear protective tape to left and right top corners of the tailgate as indicated.

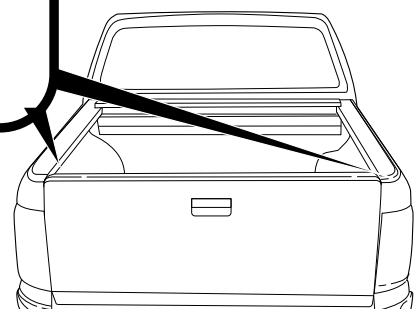
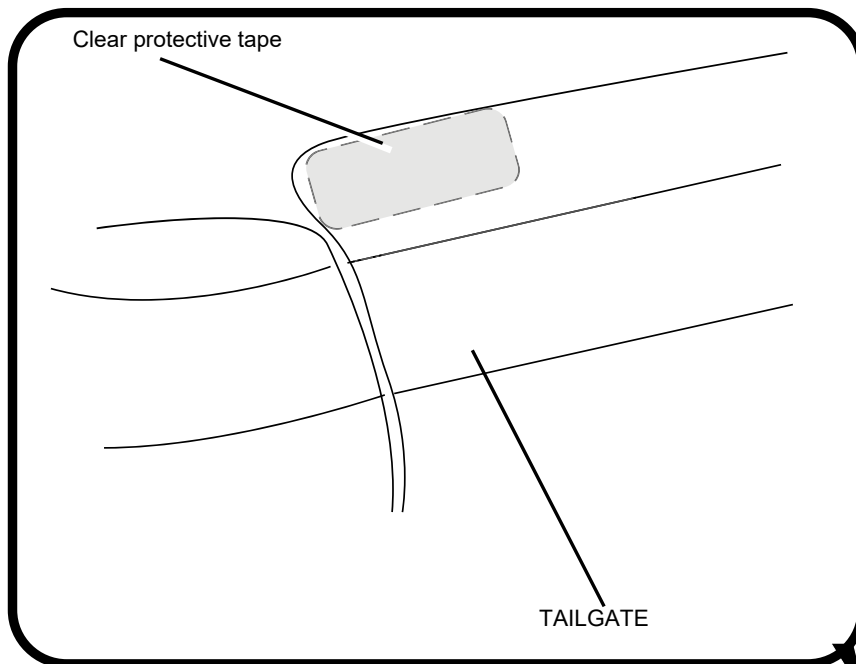
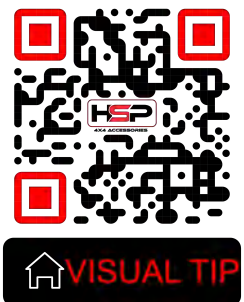

Install front drain pipes through pre-drilled holes of the canister. (RHS/LHS)



Note: With care push tube in. Gently pull the tube back so it seals correctly against the front panel of the tub.



VISUAL TIP

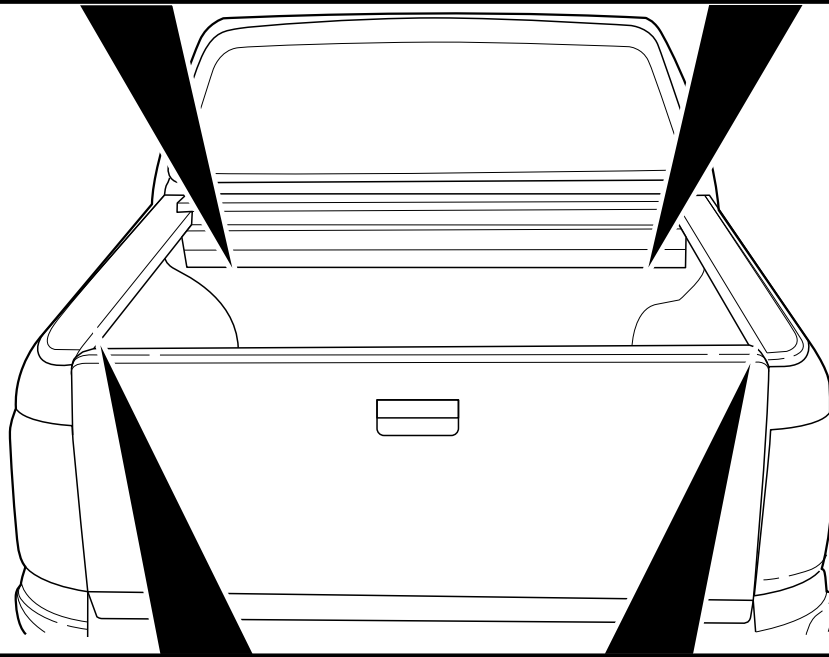
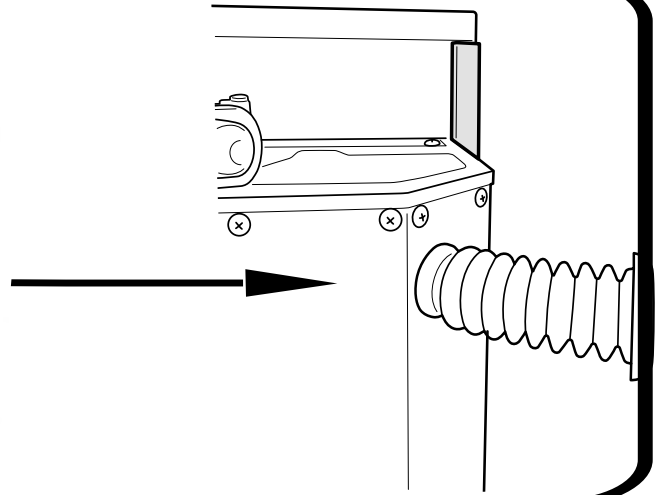
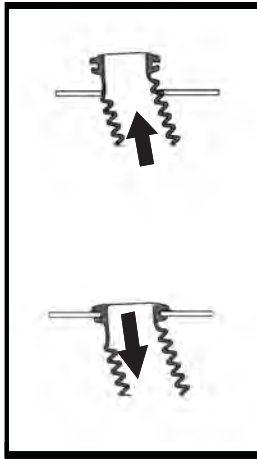

Note: With care push rear pipe in. Gently pull the pipe back so it seals correctly within the side rail channel.

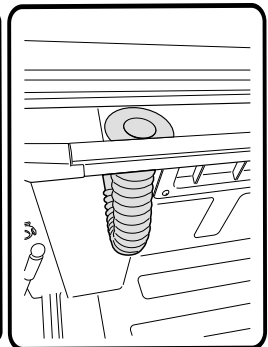
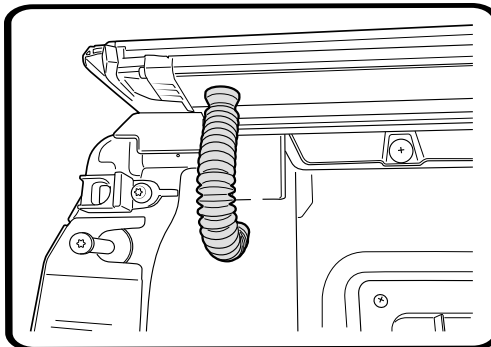
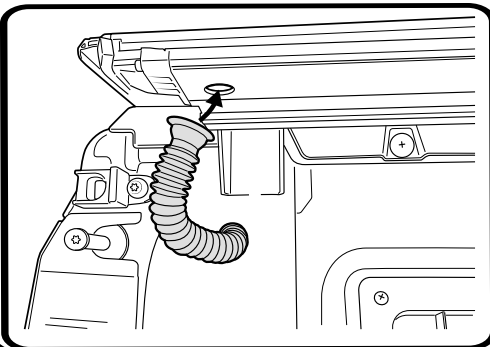
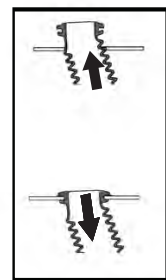

Install rear drain pipes through pre-drilled holes of the siderails. (RHS/LHS)

- a. Connect Battery loom S2.75 to Receiver loom.
- b. **Carefully** connect CI-Loom-short to Receiver loom.



Align connectors carefully to avoid pushing pins out.

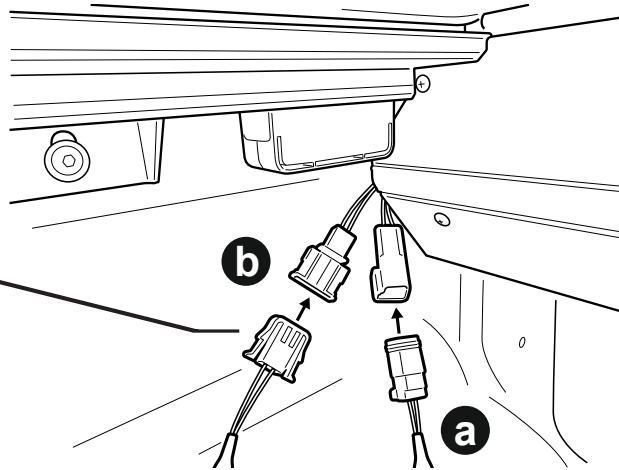

NOTE: 1. To wear in the Roll R Cover please fully open & close the cover approximately 15 times after install is complete.

2. Set your vehicle locking system to unlock all doors with one press of the factory remote unlock button. This setting can be found in your vehicle settings.

Operating instructions:

Press unlock on vehicle key fob to activate controller.

When vehicle is unlocked the side rail sensor buttons will be active to control.

When vehicle is locked the side rail sensor buttons will be inactive.

Using factory key fob to operate:

Pressing unlock twice on the factory key fob within 4 seconds, will activate the roll r cover to open.

Pressing lock twice on the factory key fob within 4 seconds, will activate the roll r cover to close.



Vehicle proximity:

Tapping the proximity twice to open or lock the car door will act exactly the same way as the key fob being pressed twice.

Touch & let go to open, touch & let go again to pause.

Touch & let go to close, touch & let go again to pause.

