



## **Important Information!**

**Please note that with the box of the Roll R Cover, there is a service kit that includes:**

- A User Guide**
- Specific Lubrication**
- A Servicing Guide**
- A Warranty Guide**

**This must be handed over to the end user in order for them to register their warranty and understand the servicing requirements.**

**ROLL. R. COVER<sup>®</sup>**  
**SERIES 3**



# INSTALLATION INSTRUCTIONS

## New-Gen Mitsubishi MV Triton

This instructions has QR codes on relevant sections. You must scan the QR codes via your smart phone camera and watch the video to ensure your fitment is to standard.



**INSTALLATION TIME:** 1 hours and 45 minutes (Approximately)

<p><b>IMPORTANT</b></p>	<ul style="list-style-type: none"> <li>• Do not stand/sit or rest heavy objects on Roll R Cover</li> <li>• Humans or animals are not to be under the closed cover at any given time</li> <li>• Tonneau Cover is not dust or water tight</li> <li>• If contact with volatile chemicals occur, clean Cover with mild detergent and water solution</li> </ul>		
<p><b>Care Instructions</b></p>	<ul style="list-style-type: none"> <li>• Read Instructions fully before commencing installation.</li> <li>• Clean Cover with a mild detergent and water solution</li> <li>• Do not use abrasive cleaners or solvents</li> <li>• Refer to manufactures instructions applicable to power drill.</li> <li>• Protect Tub floor against scratches during installation process.</li> </ul>		
<p><b>Maintenance</b></p>	<p>Refer to Maintenance instructions.</p>		
<p><b>Tools Required</b></p>	<ul style="list-style-type: none"> <li>• Pen / Marker</li> <li>• Centre Punch</li> <li>• Drill &amp; Drill bits</li> <li>• Caulking Gun</li> <li>• Silicon - Non Acetic</li> </ul>	<ul style="list-style-type: none"> <li>• Scissors &amp; Knife</li> <li>• Spanner &amp; Socket</li> <li>• Tape measure</li> <li>• Holesaw</li> <li>• Filing tool</li> </ul>	<ul style="list-style-type: none"> <li>• Soapy water solution</li> <li>• Allen Key set</li> <li>• Screw driver</li> <li>• Rust Inhibitor</li> <li>• Trim Removal Tool</li> </ul>

**PERSONAL PROTECTIVE EQUIPMENT:**



Rubber Gloves



Goggles



Hearing Protection

## BOX CONTENTS

**LEFT & RIGHT SIDE RAIL**

S2.5-DC-AE-002ps-TD4 

S2.5-DC-AE-003ds-TD4 



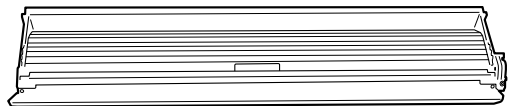







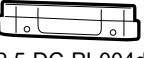

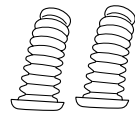

**CANISTER ASSEMBLY**

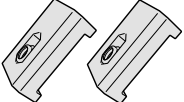
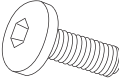

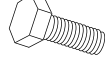
**S3-DC-AF-TR-001/002**

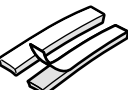
**CANISTER TOP COVER**  **S2.5-DC-AE-005 -LD4**

### SPECIFIC KIT LD4R

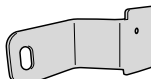
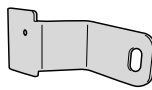
<p><b>COVER END CAPS</b></p>  <p>S2.5-DC-PI-004ps</p>  <p>S2.5-DC-PI-004ds</p>	 <p><b>COUNTERSUNK SCREW Qty - 4</b></p>	 <p><b>CABLE TIE Qty x 24</b></p>	 <p><b>BATTERY LOOM S2.75</b></p>	 <p><b>Drainage pipe Qty - 2</b></p>	 <p><b>Rear Drainage pipe Qty - 2</b></p>
 <p><b>SIDERRAIL CLAMP Qty - 4</b></p>	 <p><b>M8 x 35mm Qty - 4</b></p>	 <p><b>M8 WASHER Qty - 6</b></p>	 <p><b>M8 SPRING WASHER Qty - 6</b></p>	 <p><b>M8 x 20mm Hex head bolt Qty - 2</b></p>	 <p><b>M8 NUT Qty - 4</b></p>
 <p><b>50449 D-SPONGE Qty-2</b></p>	 <p><b>CL-LOOM-SHORT</b></p>	 <p><b>T-PATCH-K</b></p>	 <p><b>Clear protective tape ( 30mm x 65mm) Qty - 2</b></p>	 <p><b>S3.0-DC-AE-003 LH</b></p>	 <p><b>S3.0-DC-AE-003 RH</b></p>

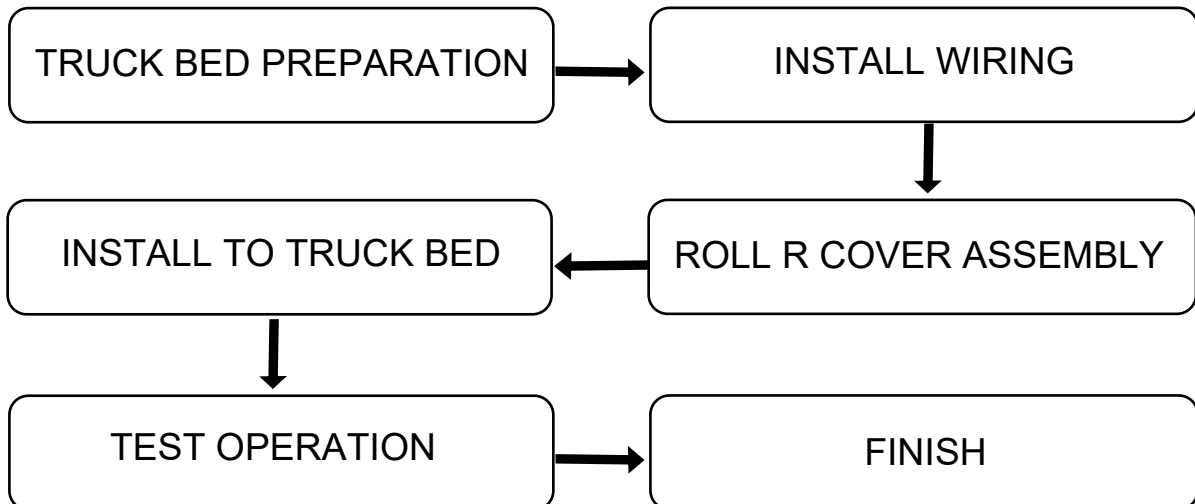

## TUB PREPARATION

If the Vehicle is fitted with a cabin guard or sports styling bar, remove from Ute Tub (truck bed).

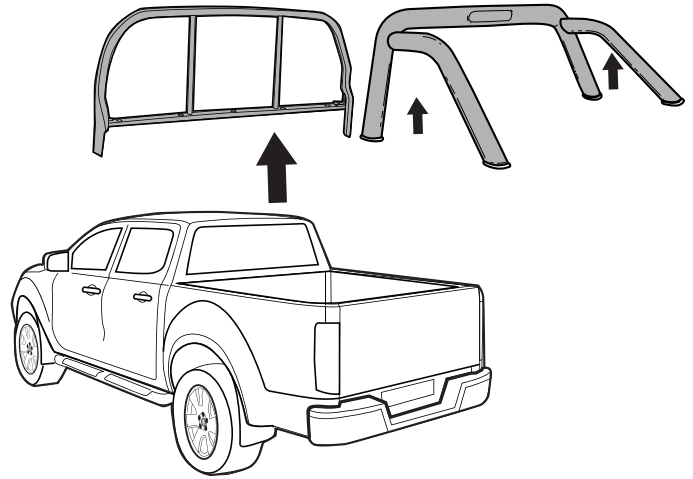

Clean area as indicated.

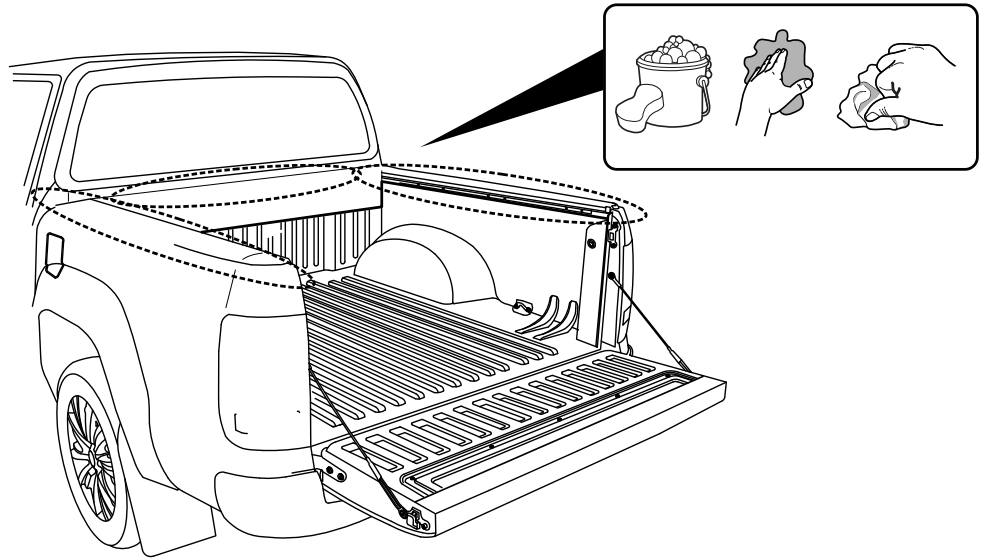

Remove and discard the indicated M8 torx bolt located to the rear of the tub.

Repeat to the other side.

**Note: If the bed is fitted with a tub liner, you will need to trim the liner to expose the bolt.**

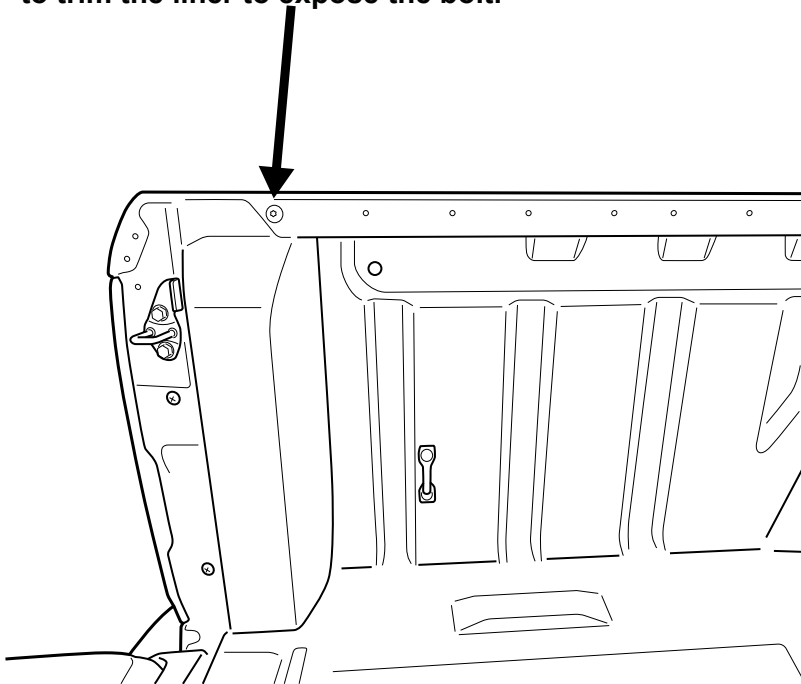
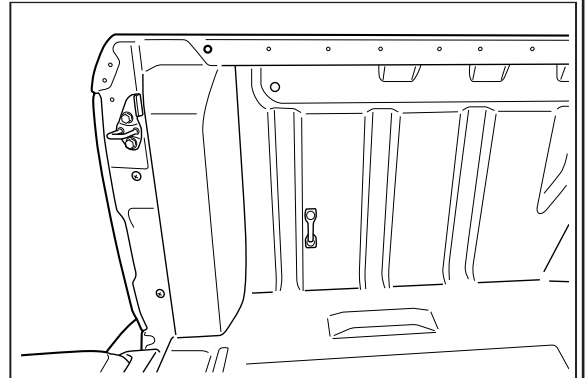

The following steps are for vehicles with bed liners. If there are no bed liners installed move to next page.

Measure 160mm down from top of Ute bed ( head rail ) and mark across to the other side.  
Trim front of bed liner by 160mm from the top of the Ute bed as shown.

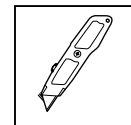
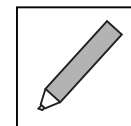
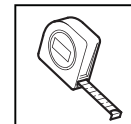
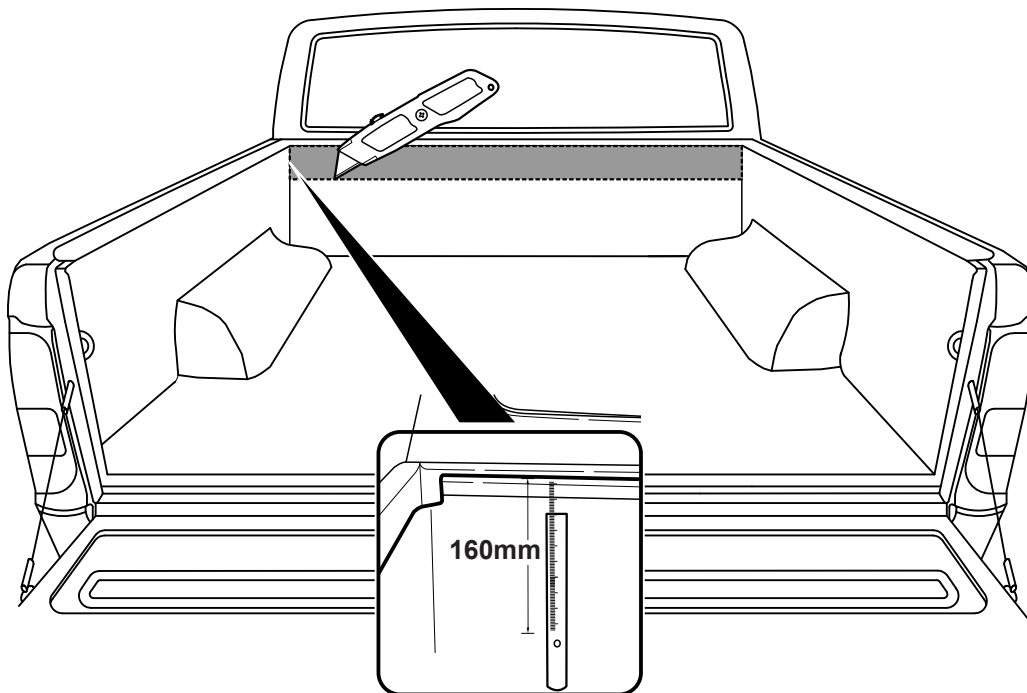

Cut a 20mm split for bed liner to flex.

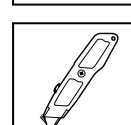
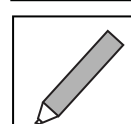
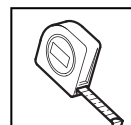
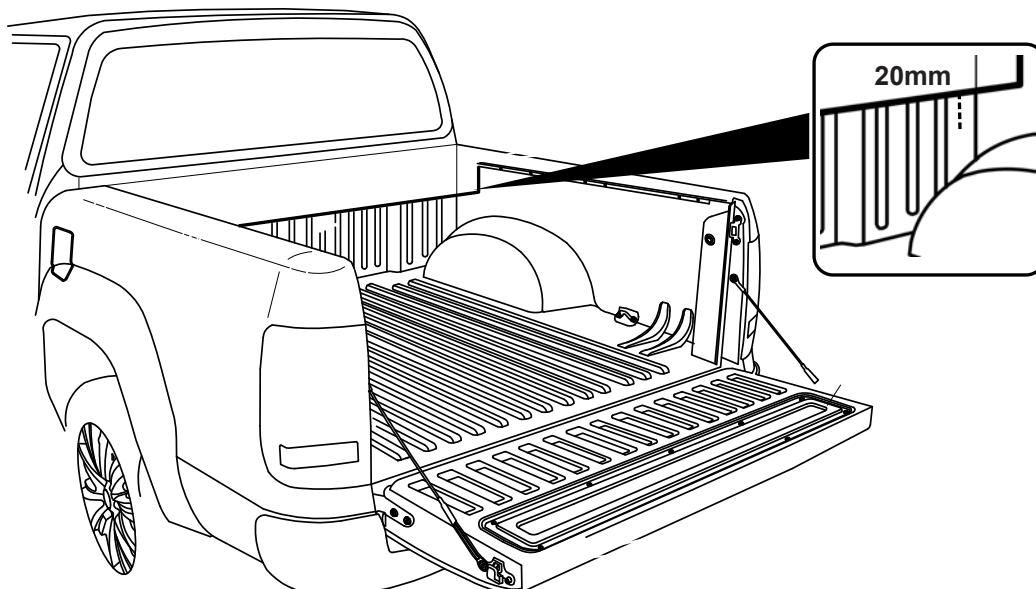

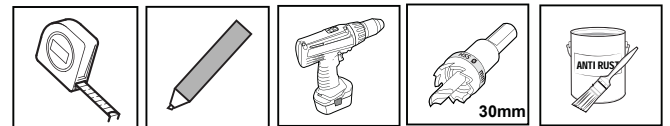
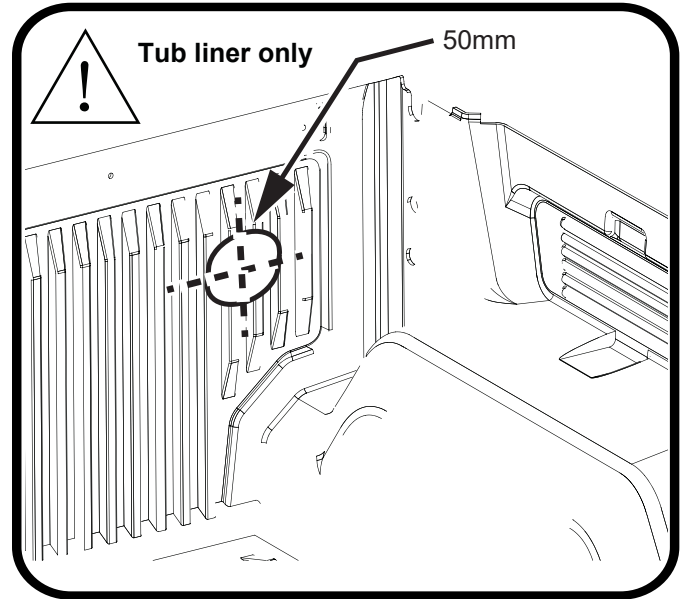
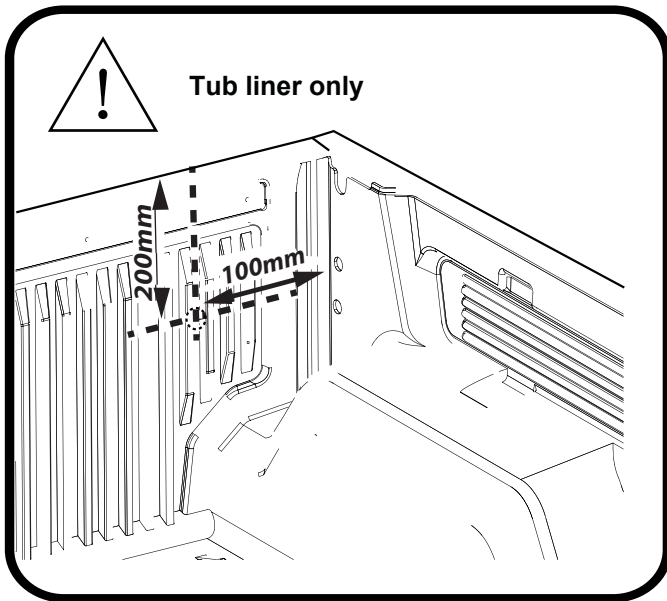
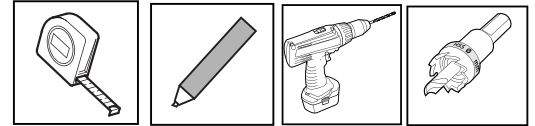

The following step is for vehicles with bed liners. If there are no bed liners installed move to next step.

Measure down from top of headboard 200mm & 100mm from inside wall of bed liner as shown. Repeat to the other side. Using a 50mm hole-saw drill the liner only as indicated.

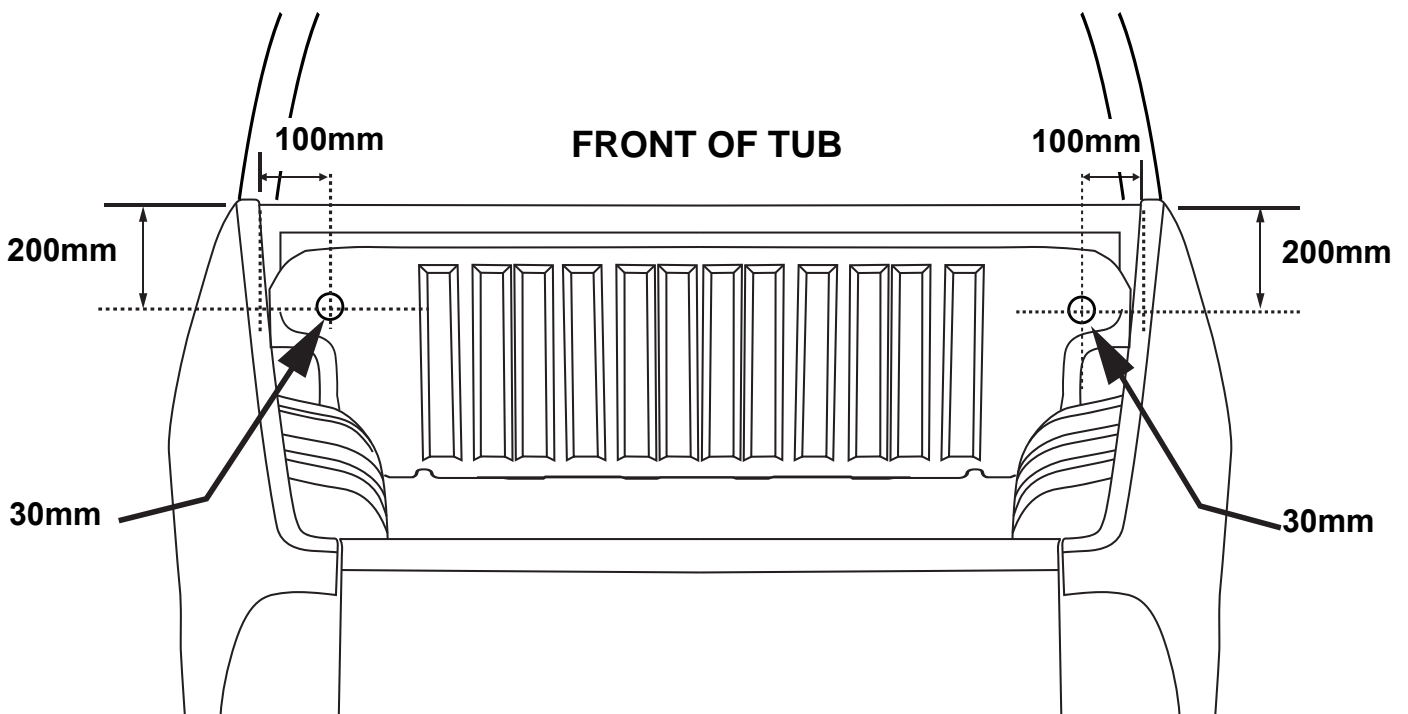

Measure down from top of headboard 200mm & 100mm from inside wall of bed as shown. Repeat to the other side. Using a 30mm hole-saw drill through tub front panel, file away any sharp edges. Apply anti rust coating. Repeat to other side.



 **ATTENTION:** Do not exceed 30mm hole.

Seal any exposed gaps or holes on the front panel of the Ute bed with sealant.

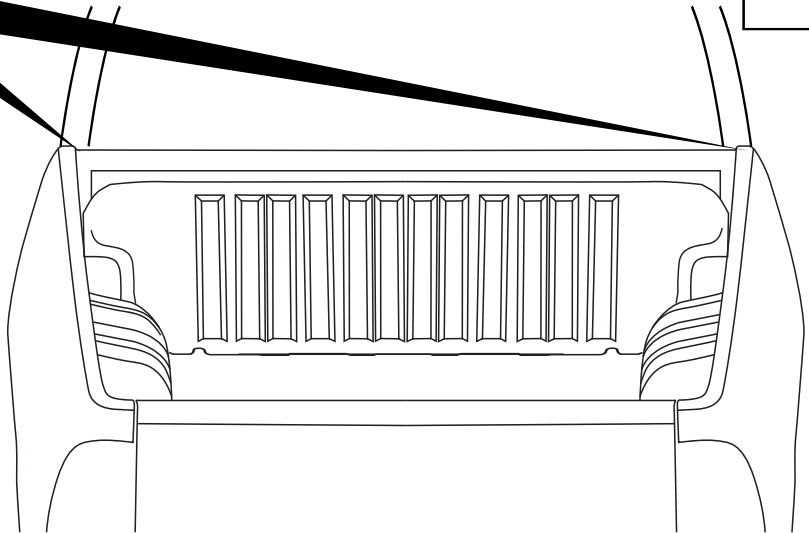
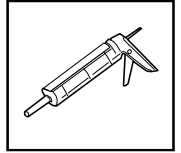
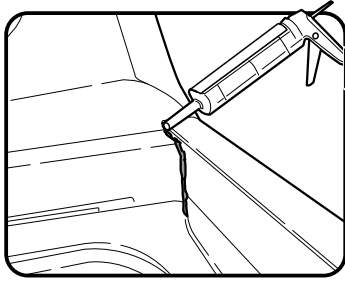

Carefully unpack the box.

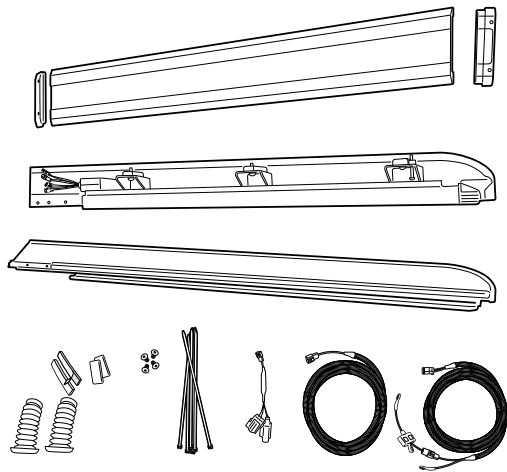
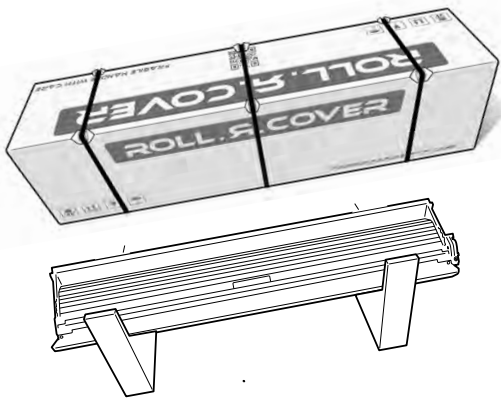

Install front drain pipes ( 55mm diameter end of hose) through pre-drilled holes on the front tub panel.



Note: With care push tube in.  
Taking care pull the tube back so it seals correctly against the front panel of the tub.

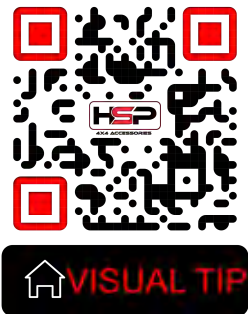
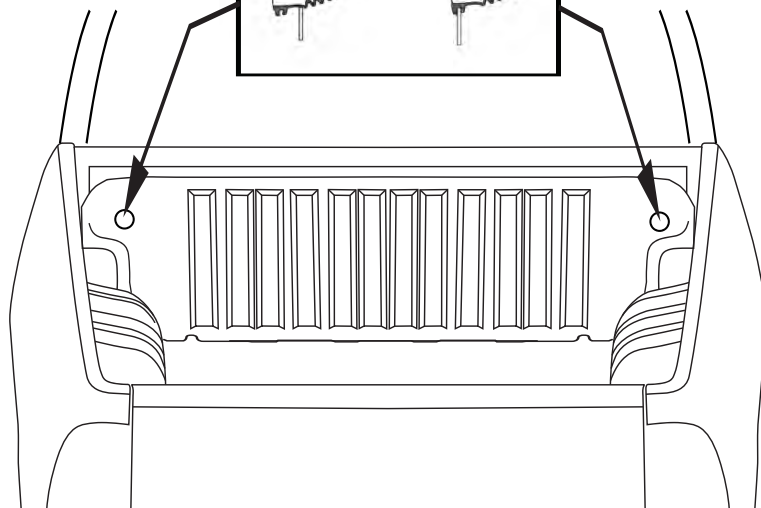
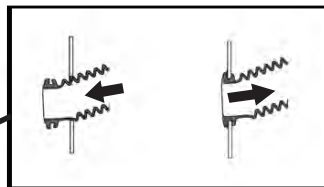

Remove and retain tail lights.

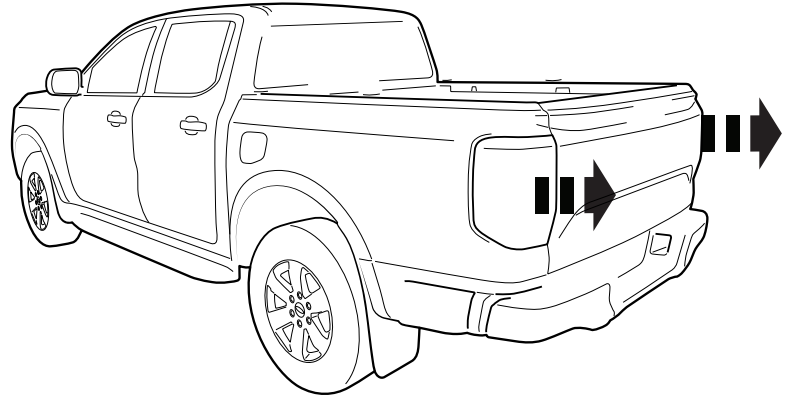

Measure 30mm towards the tailgate from the center of the indicated factory M8 thread exposed after removing the torx M8 bolt. Measure down 60mm from the top edge of the tub as directed and make a mark. Use a 15mm hole-saw to drill through the tub pillar, and file away any sharp edges. Apply an anti-rust coating. Repeat the same steps on the other side.



**! ATTENTION:** Do not exceed 15mm hole.

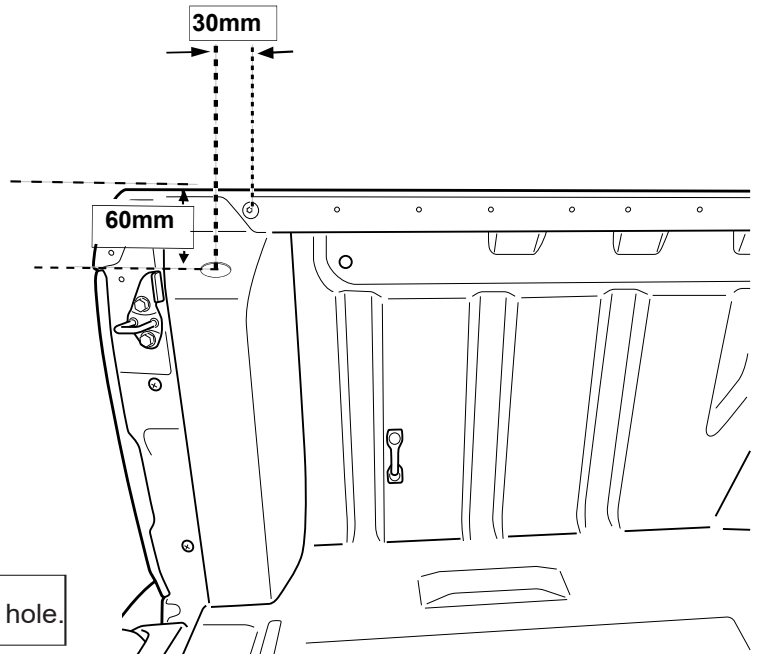

- a** In the specified orientation insert the rear drainage pipe into the previously drilled hole.
  - b** Leaving 150mm of the pipe hanging out.
  - c** Check the tail light cavity to ensure there are no obstructions to the drainage pipe. Repeat to the other side.
- Re-fit the tail lights.

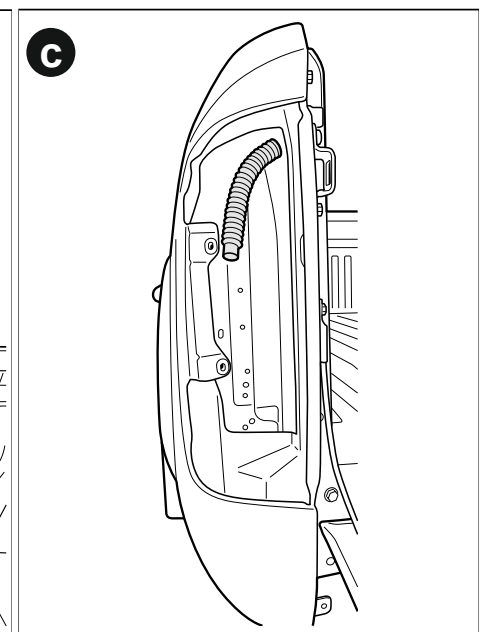
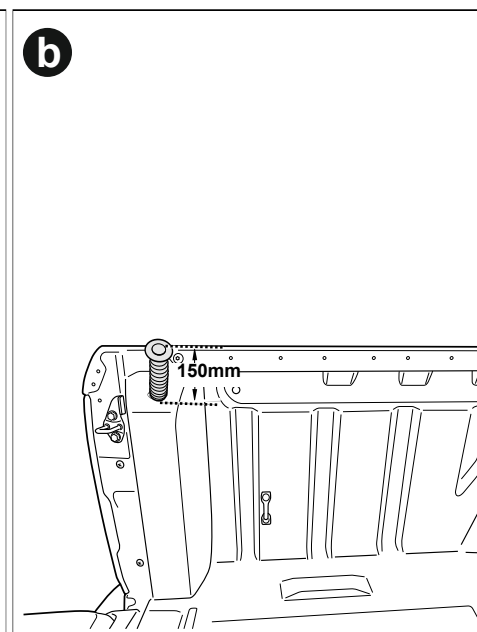
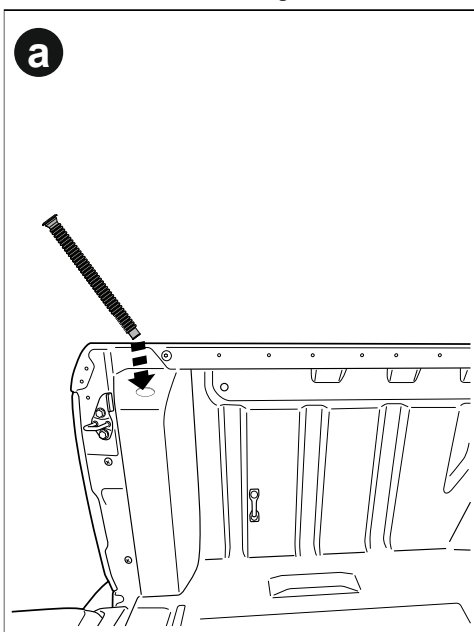



Disconnect fuse patch from battery loom S2.75.

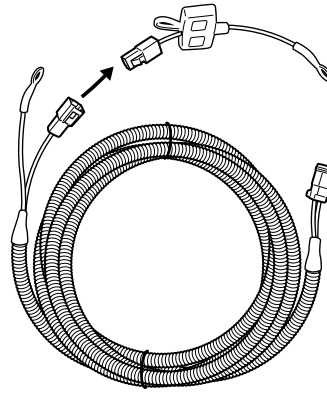

### Wiring Harness steps

**1** Feed Battery Loom S2.75 through the cavity

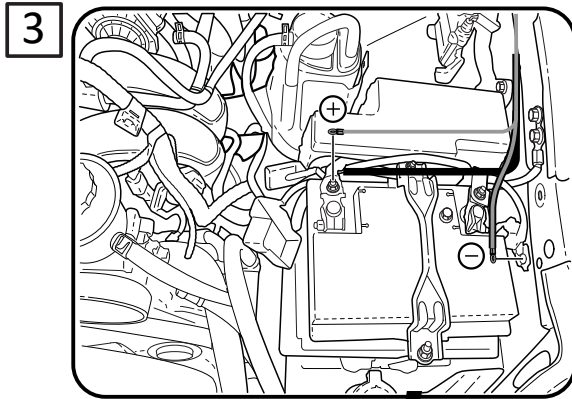
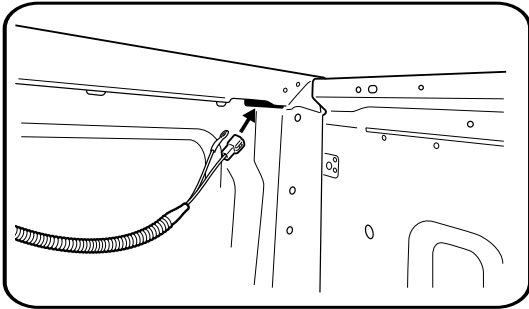

**2**

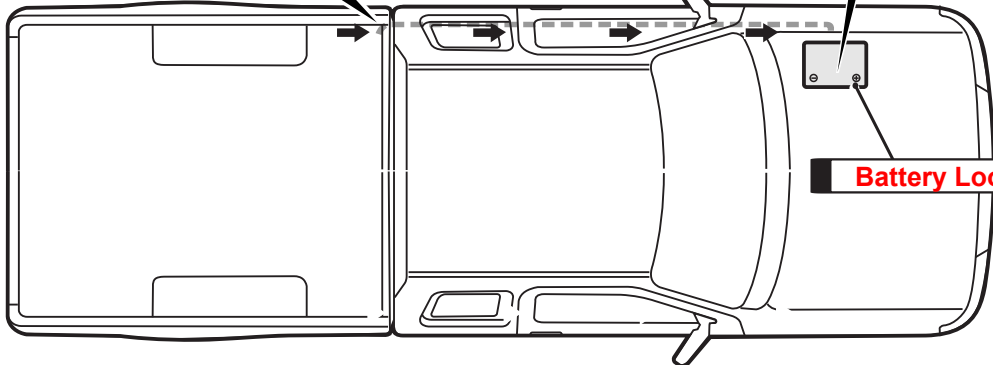

Run the wiring from the front corner cavity ( leaving 200mm in the tub) to the battery over the chassis rail. Making sure to keep away from hot obstructions and cable tie every 400mm. Reconnect fuse patch to battery loom S2.75, now attach fuse patch to positive of battery and earth to the body of the Ute.

Feed CL-Loom-Short through passenger side cavity leaving 200mm in the tub.

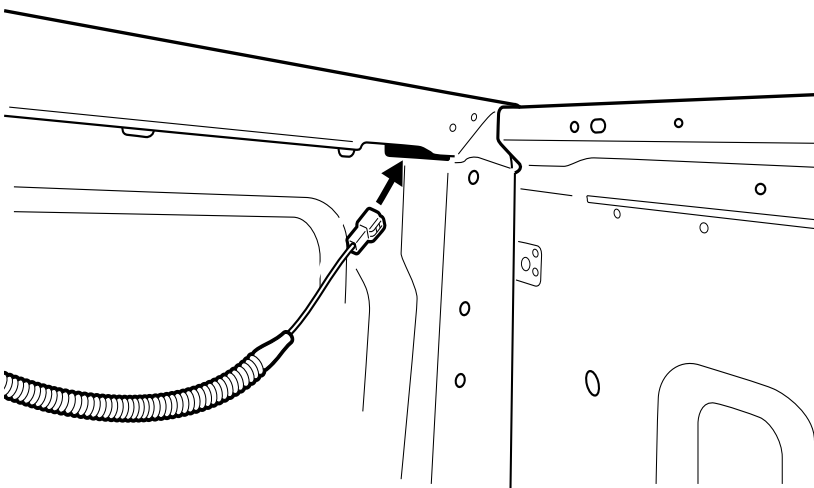

- a. Remove the harness and rubber grommet from the indicated location of the passenger side B pillar.
- b. Unplug the male and female connectors from the harness.
- c. Connect the T-patch to both the male and female connectors of the harness.
- d. Keep the harness outside for the time being.

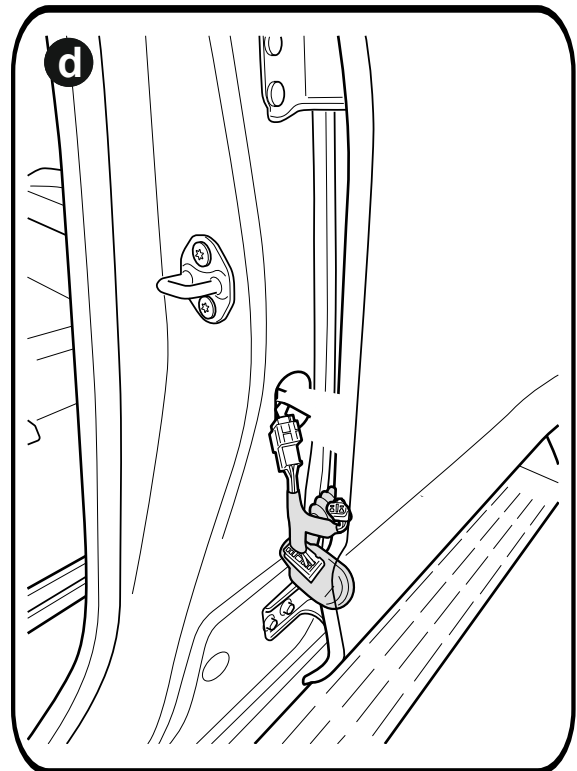
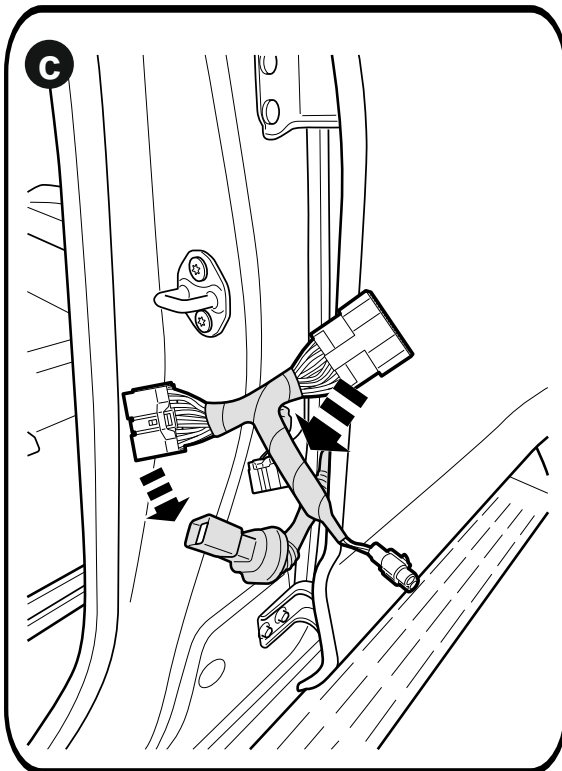
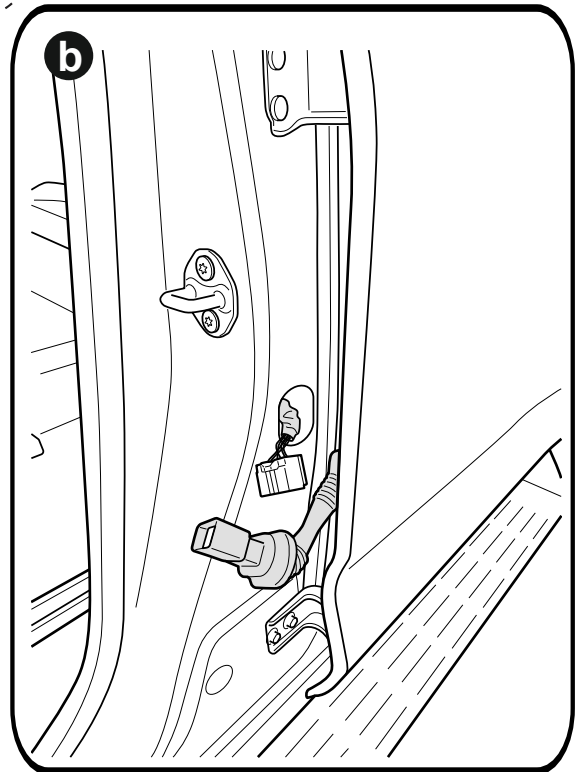
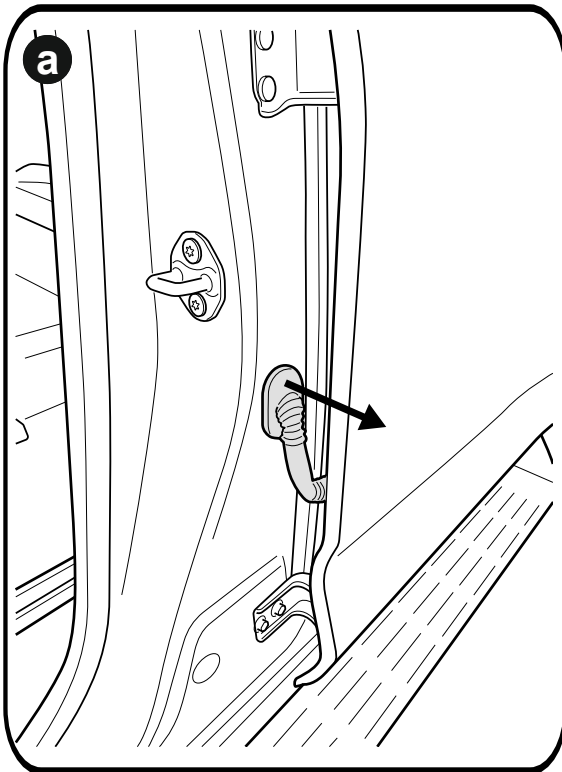
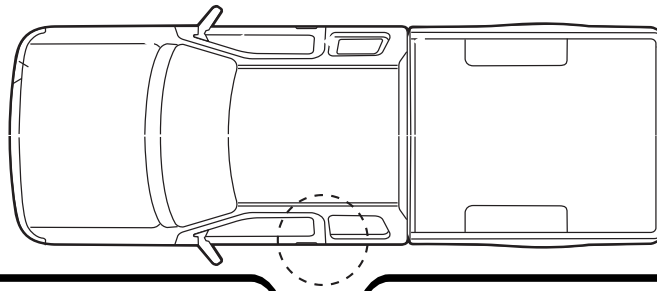

Carefully remove the front passenger side scuff panel.

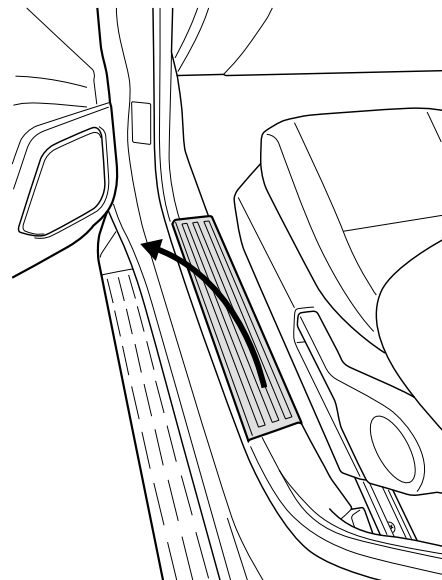

Carefully remove the rear passenger side scuff panel.

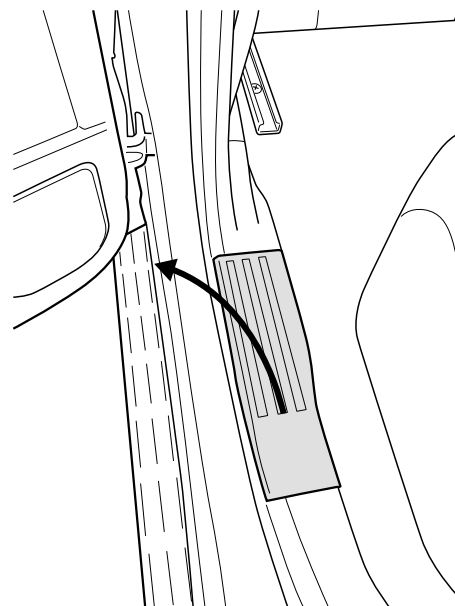

Carefully remove the passenger side B pillar lower and upper trims as indicated.

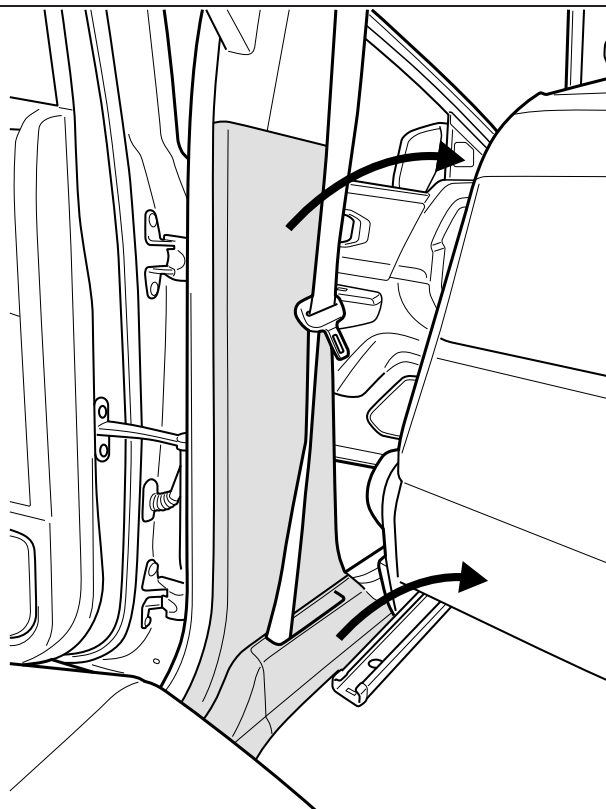

Run wiring ( CL-Loom-Short) to passenger side B pillar, Locate the large floor grommet under the carpet of the passenger side rear foot well. Remove and retain grommet.

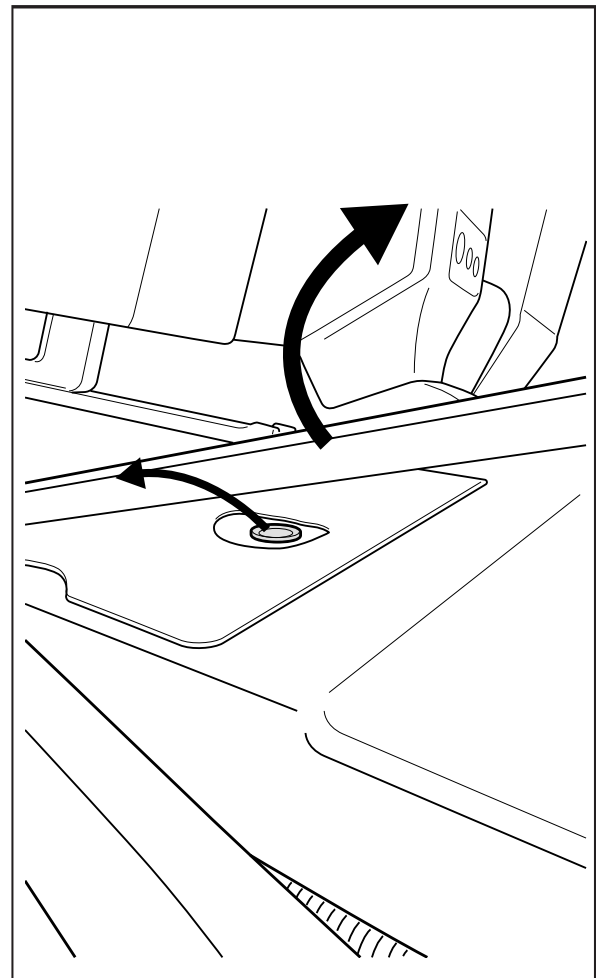
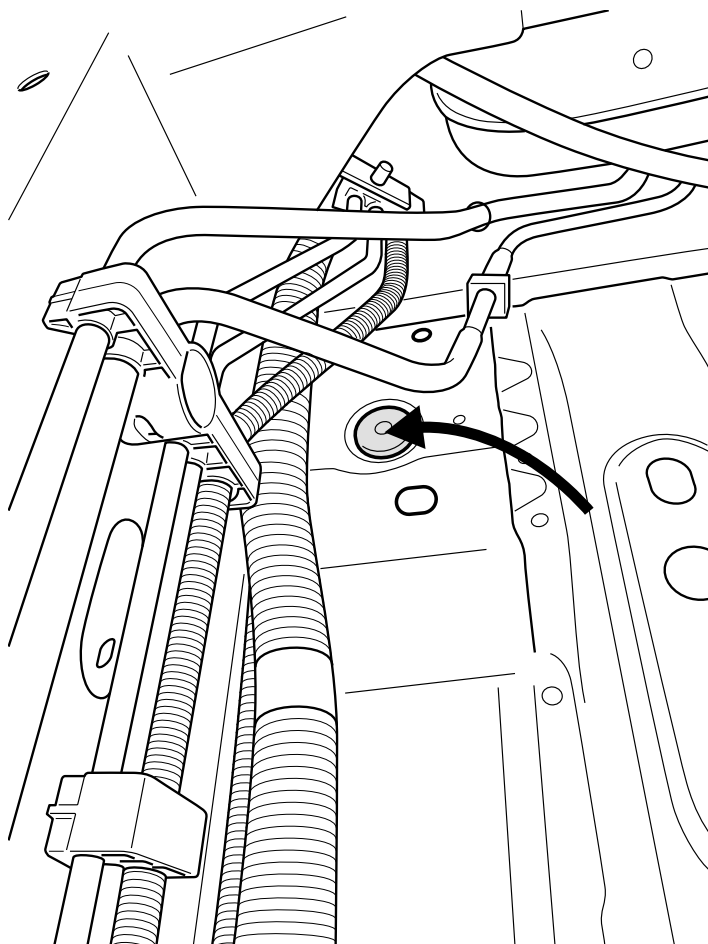
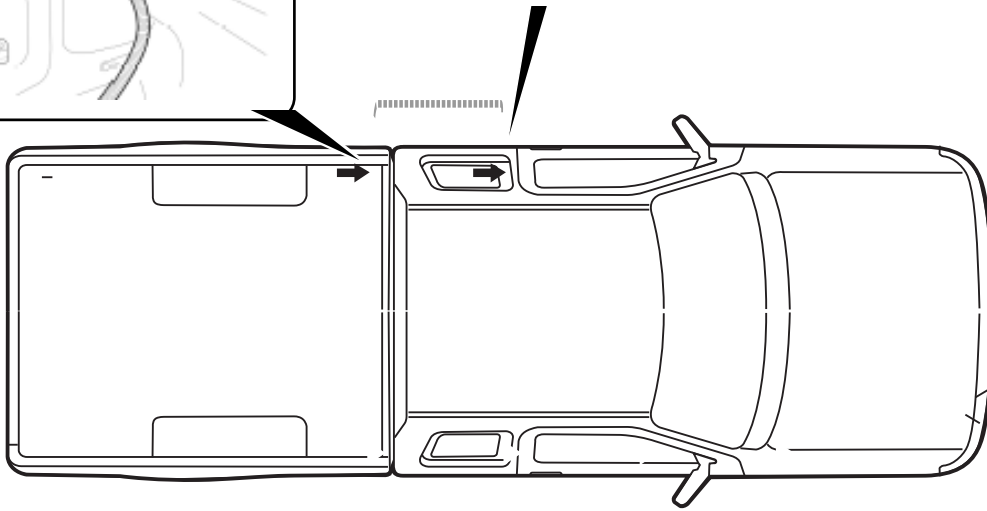
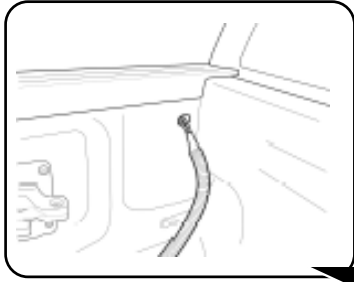

Feed CL-Loom-Short through the hole.

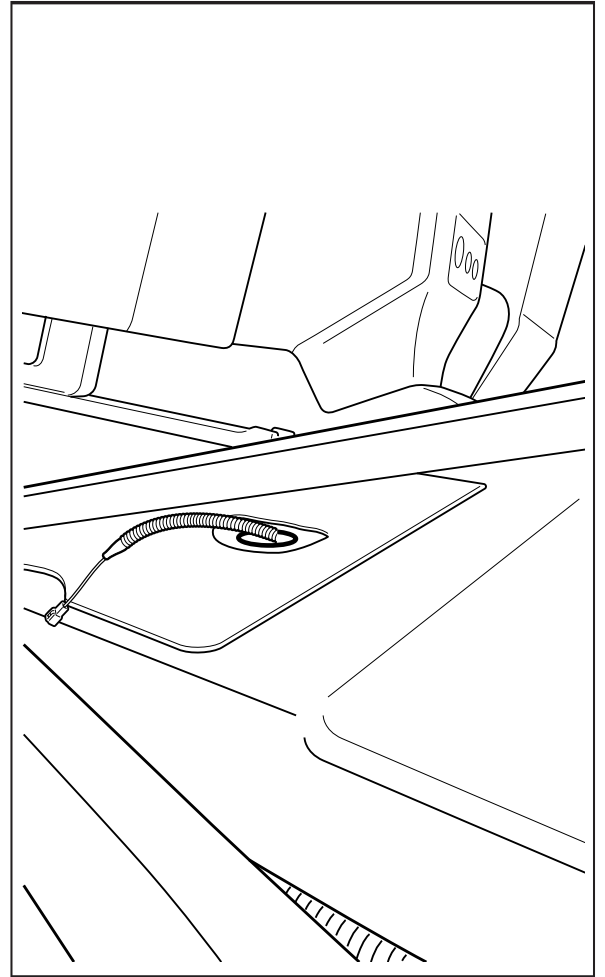
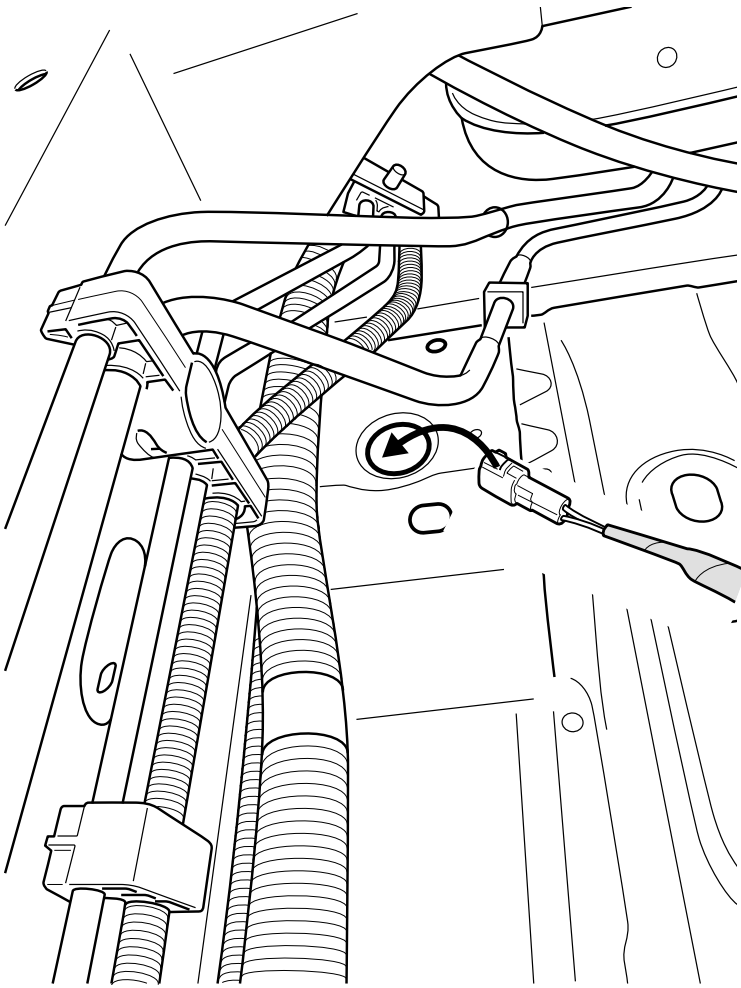

Make a small incision to the retained grommet & run the loom through it.

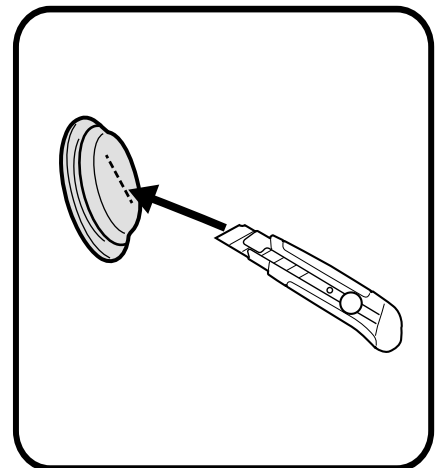
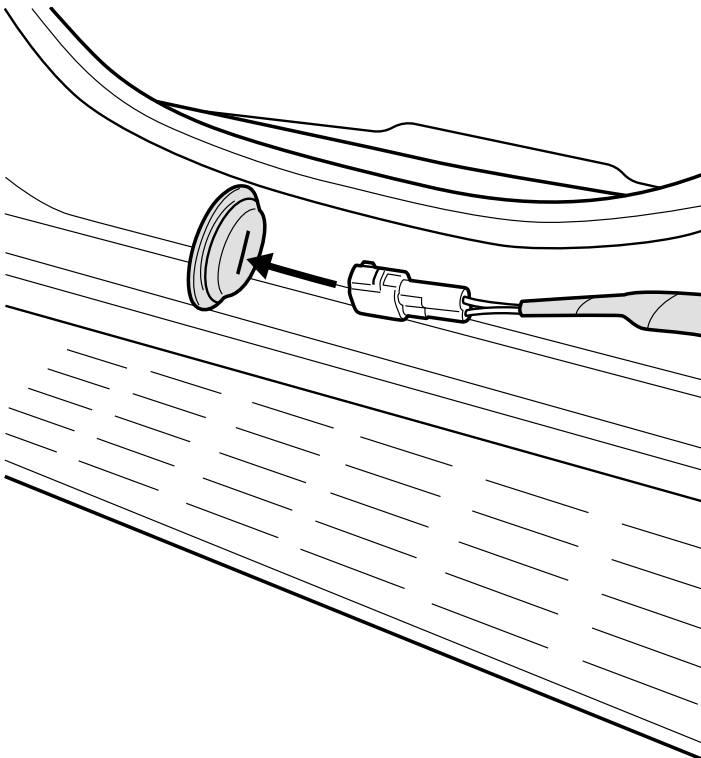

Un-clip the white indicated harness clip from the B pillar.

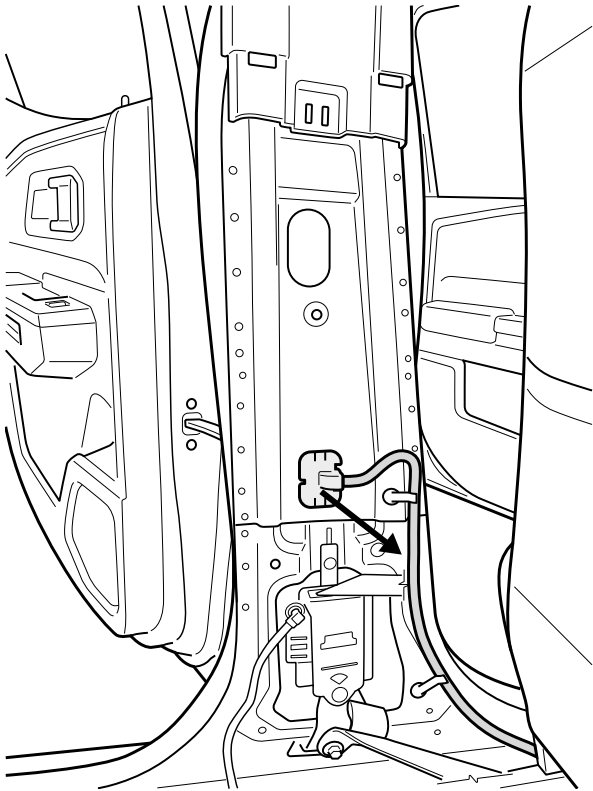

Feed CI-Loom-Short through the exposed cavity.

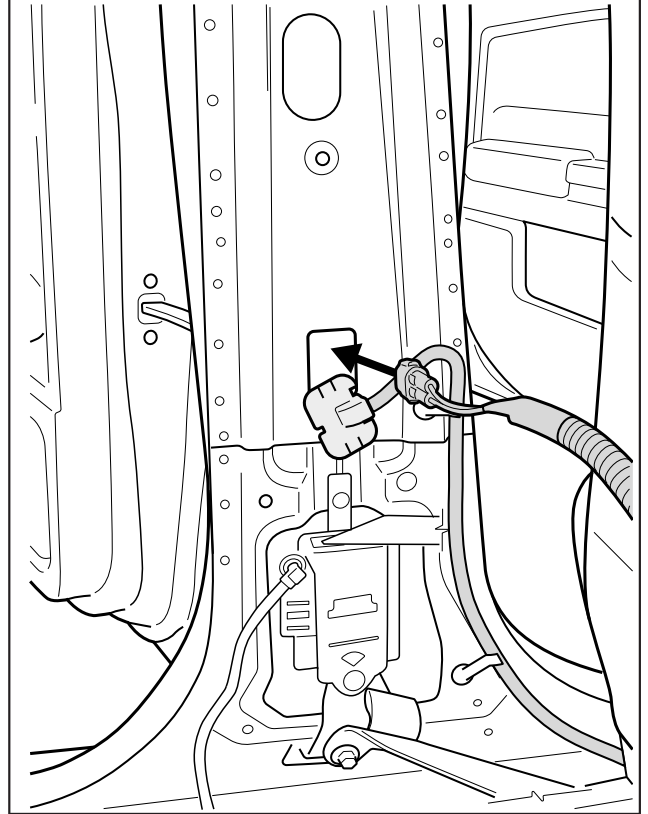

Feed CL-Loom-Short through to the outside exposed cavity of the B pillar.  
Now connect CL-Loom-short to T - Patch.

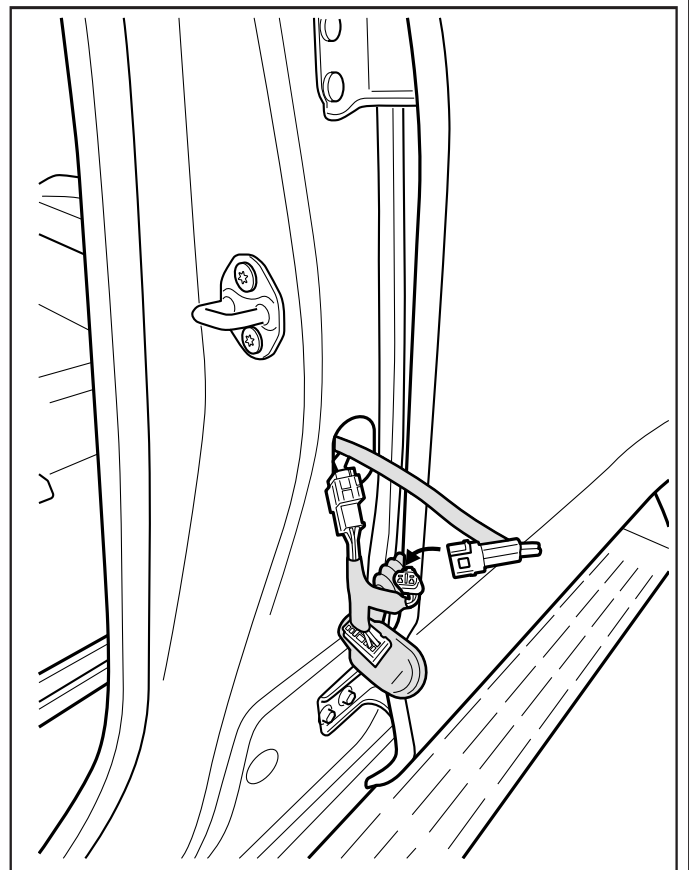
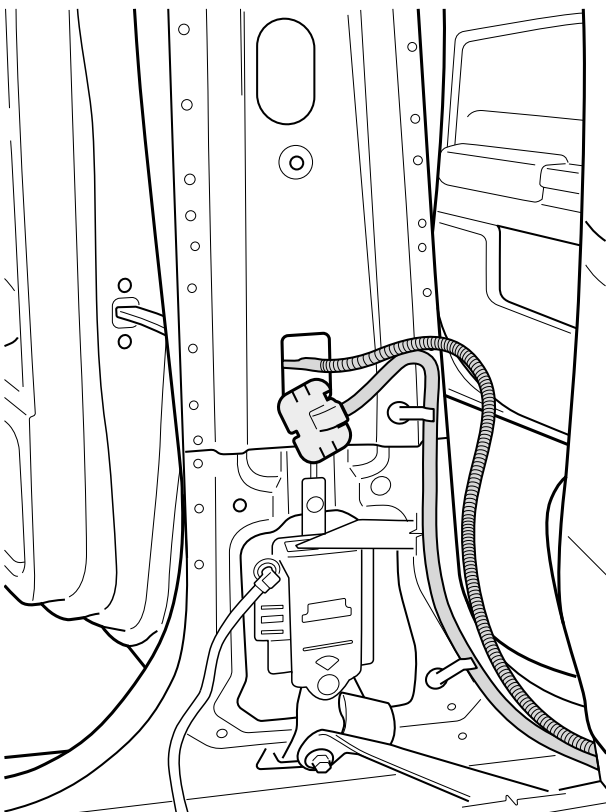

Feed harness back into cavity and re-fit the harness grommet to the pillar.

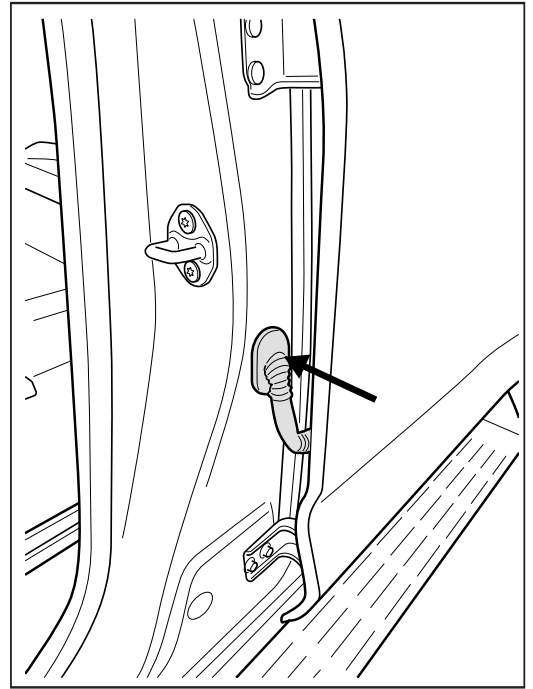
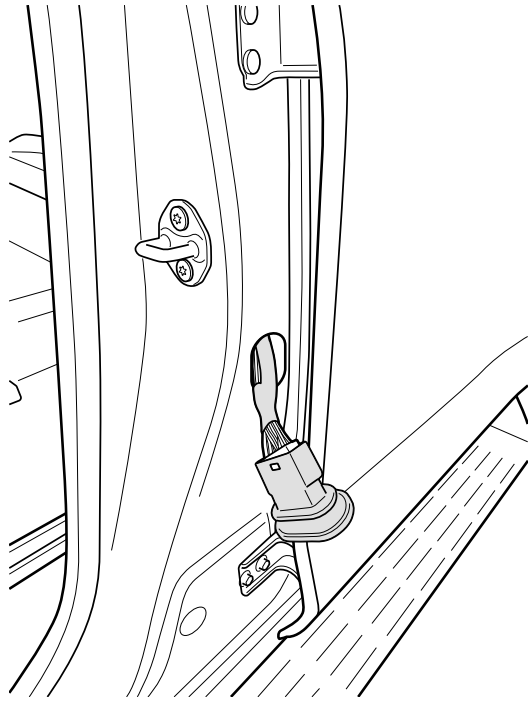

Align CL-Loom-short's conduit to indent on the pillar.  
Now with care push harness plug back in to place.

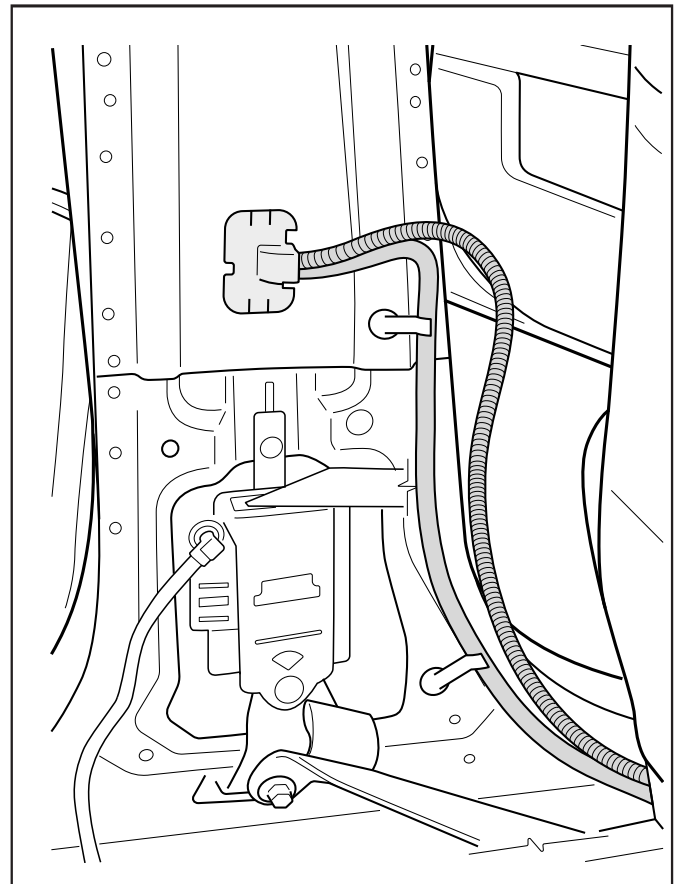
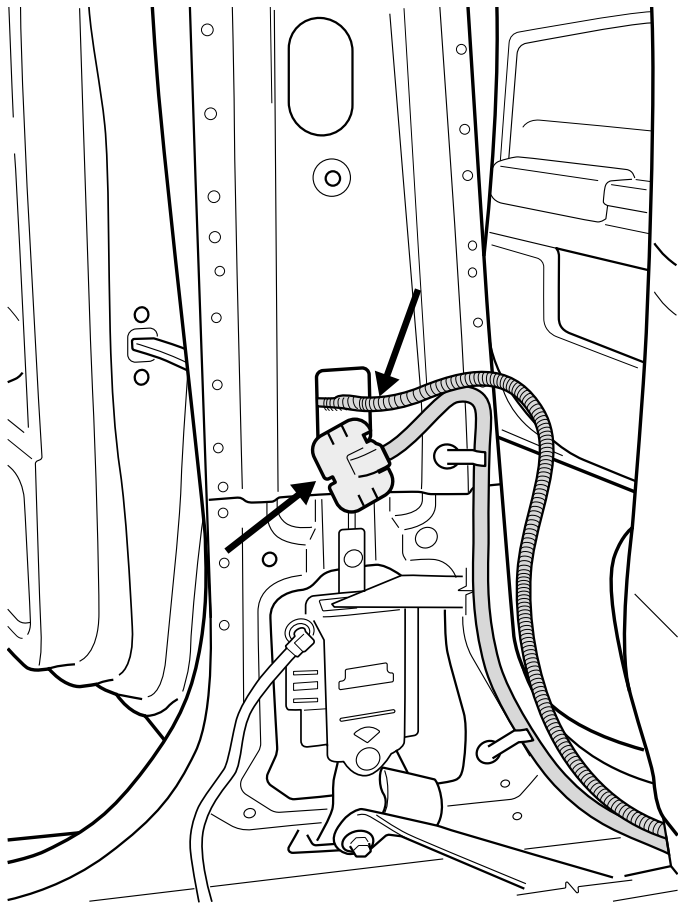

Cable tie the loom to the factory harness as indicated.

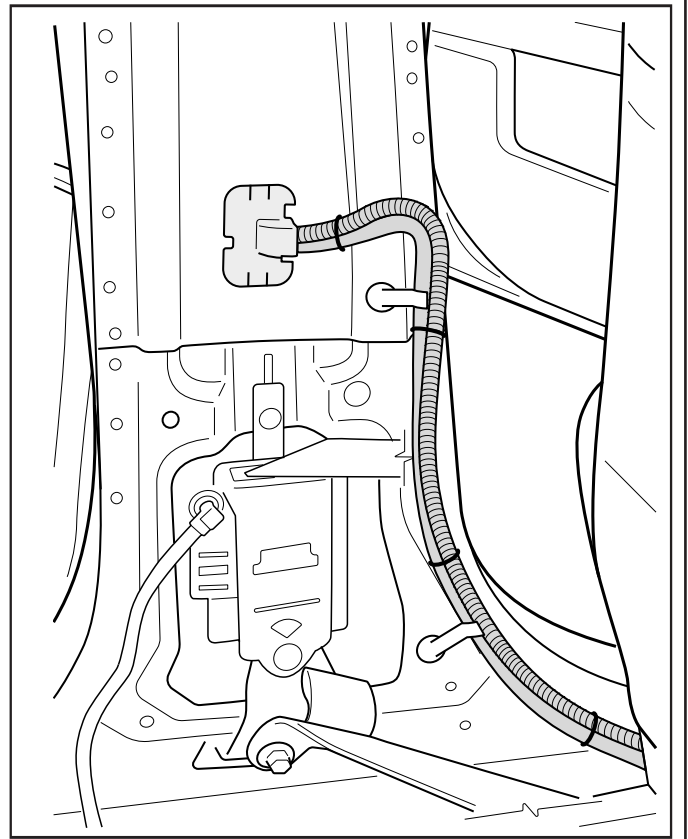
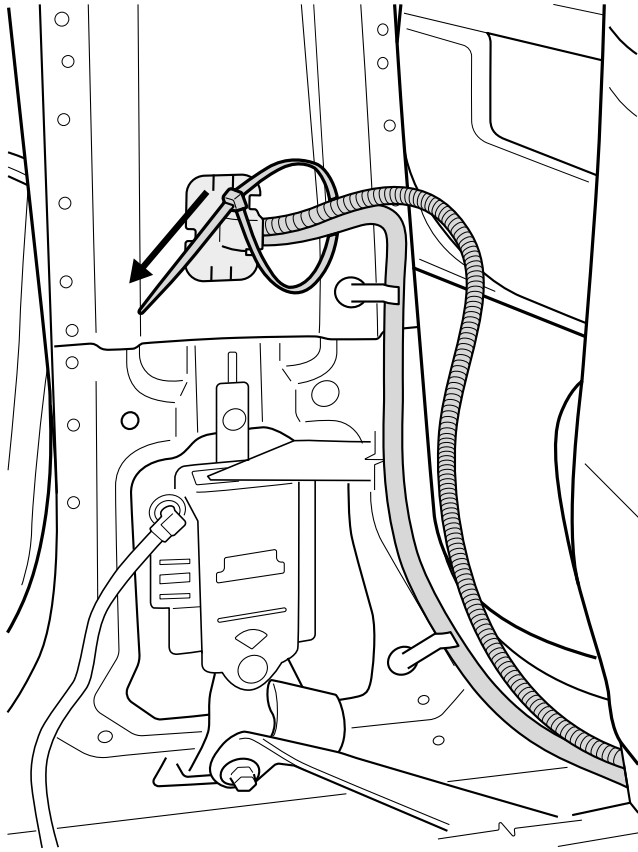

Fit grommet back into its location.

Then apply adequate amount of black sealant to the grommet's slit from top and bottom so it seals correctly. Zip tie any loose hang on the loom to the factory harness.

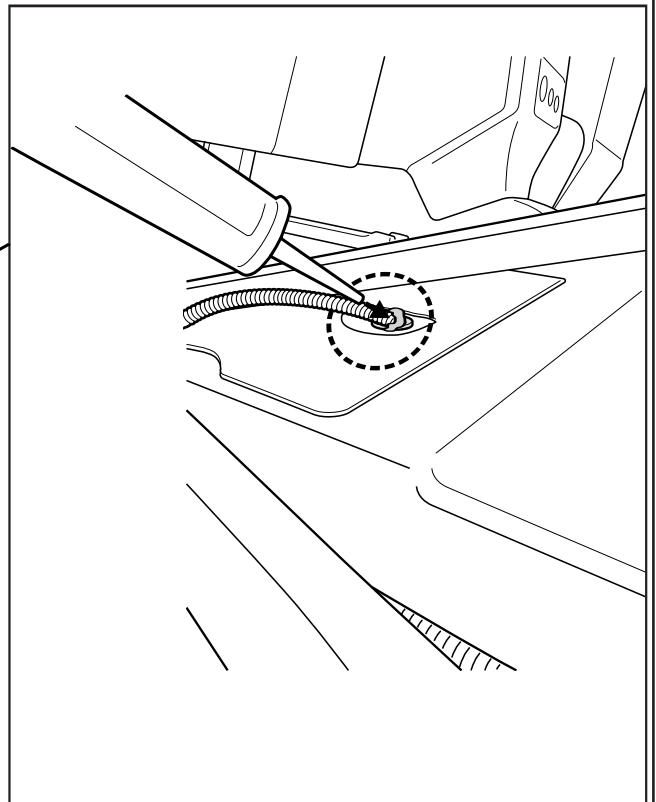
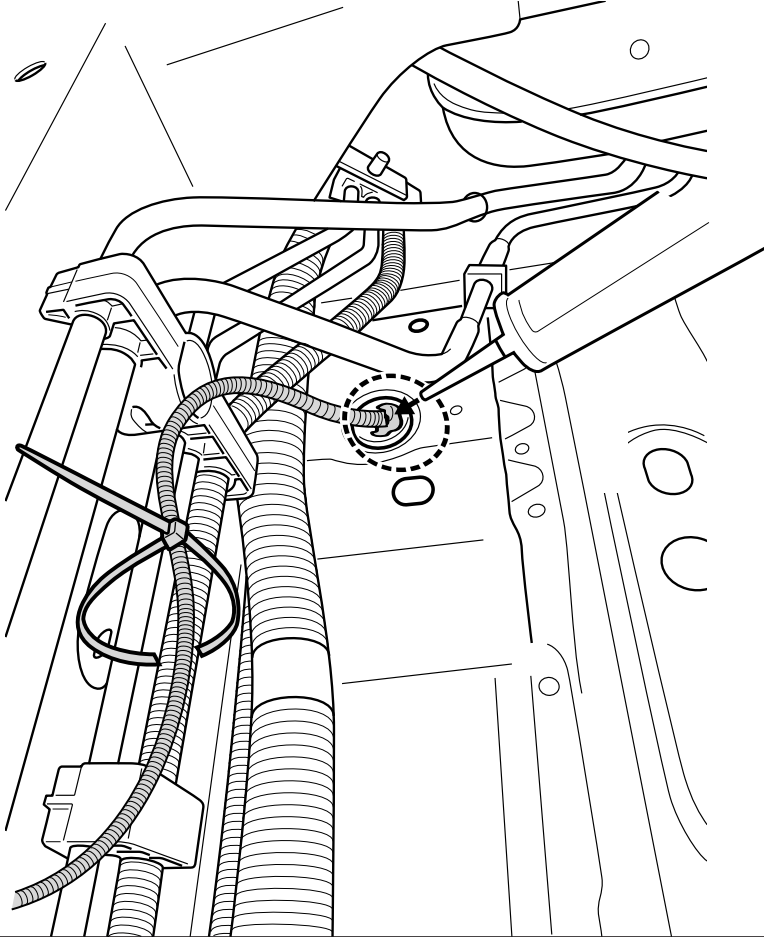



keep the cannister in the foam blocks from the packaging for assembly.

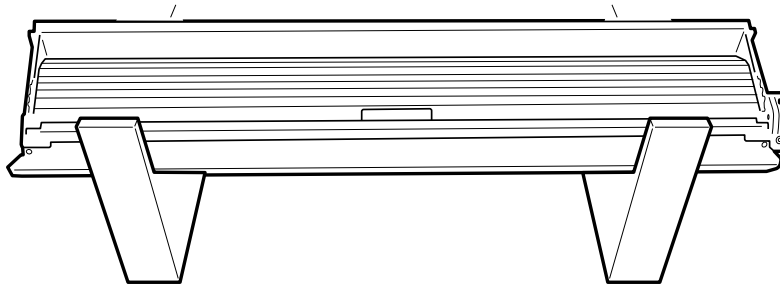
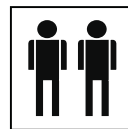

With assistance turn the canister on its back on the foam blocks.

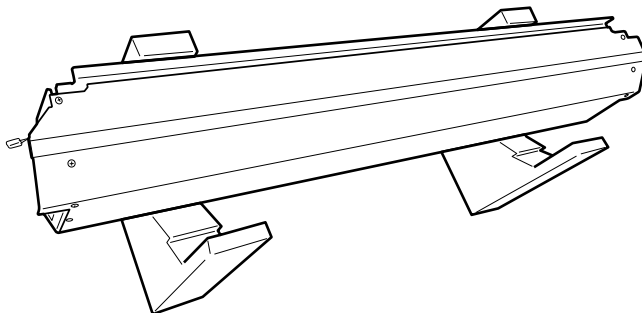

Disengage motor from the axle by unfastening the 3 Screws as indicated. Retain all parts.

Remove and retain the 3 screw from the canister as indicated.

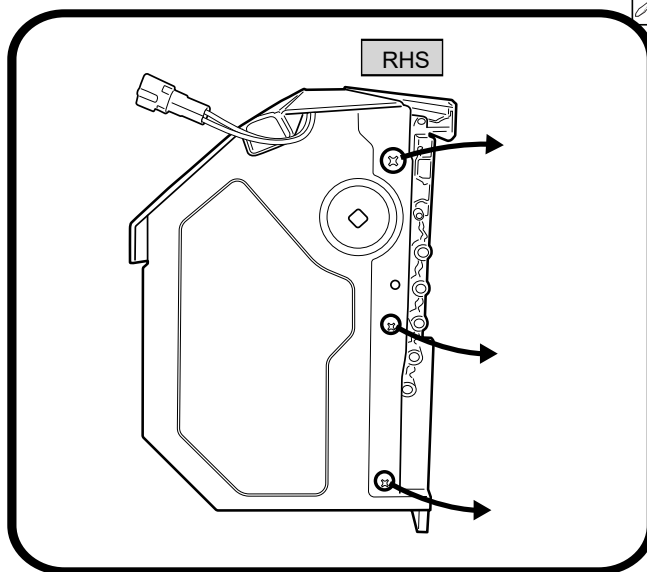
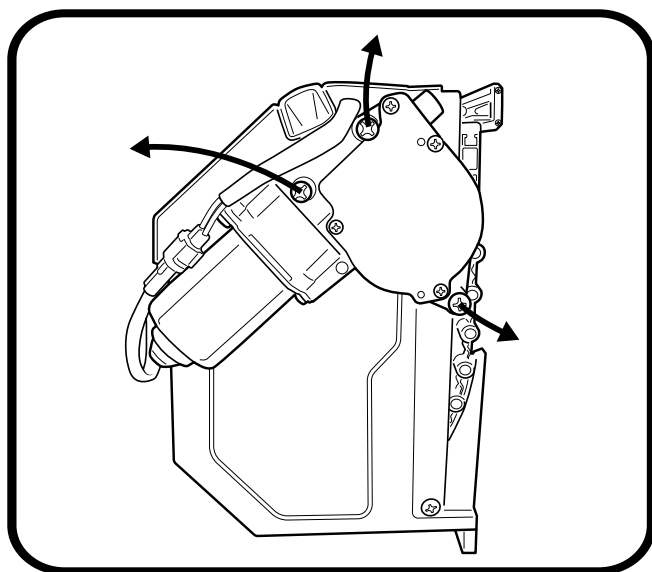

Now on the other side, remove and retain the 4 screws from the canister as indicated.

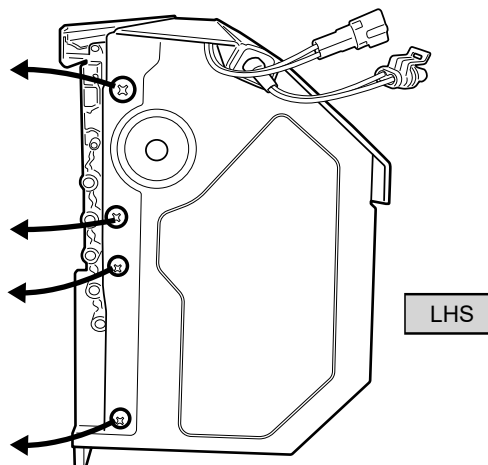
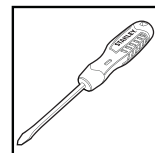



**Important Note:** Ensure that the Z seal within the track is positioned over the curtain and not folded inward. **WARRANTY** voided if assembled incorrectly.

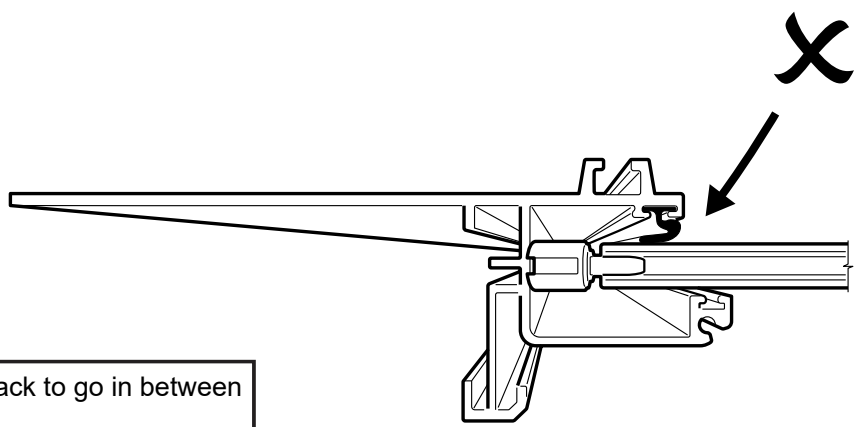
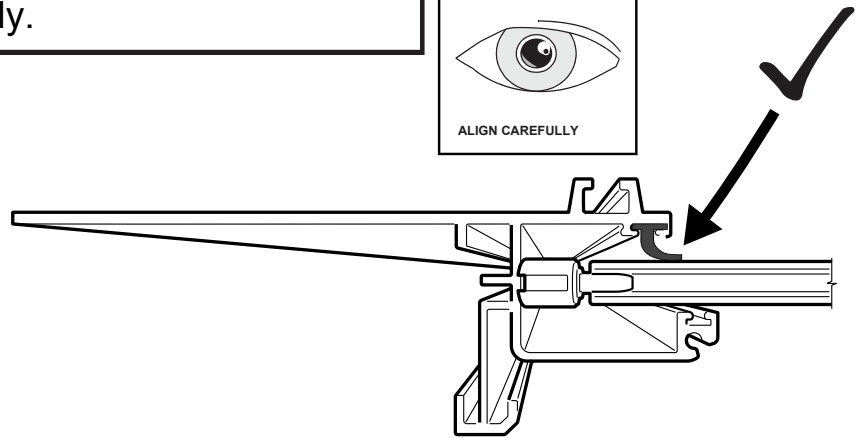
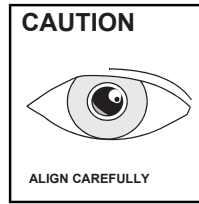

 **VISUAL TIP**

Align side rail to side of canister, guide the track to go in between the curtain end rubber stop.  
NOTE: LHS side rail to be assembled first.

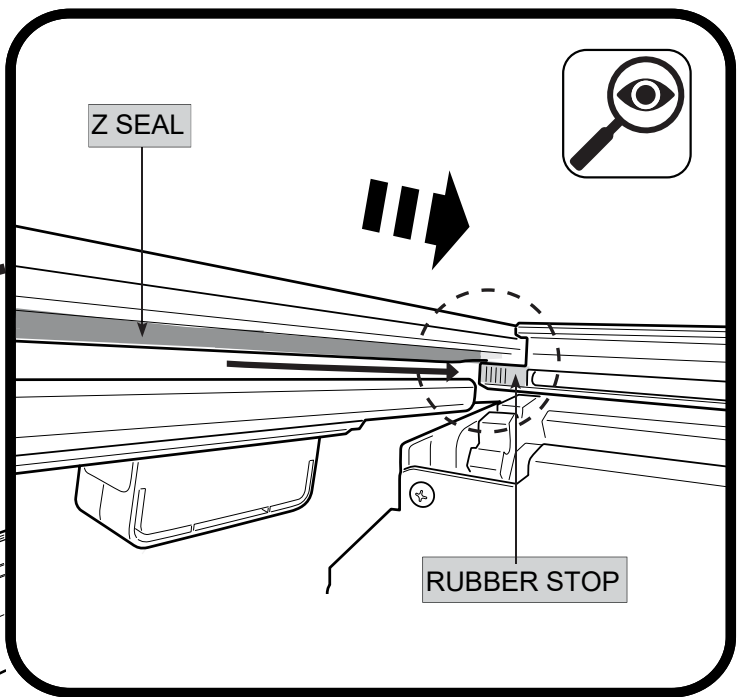
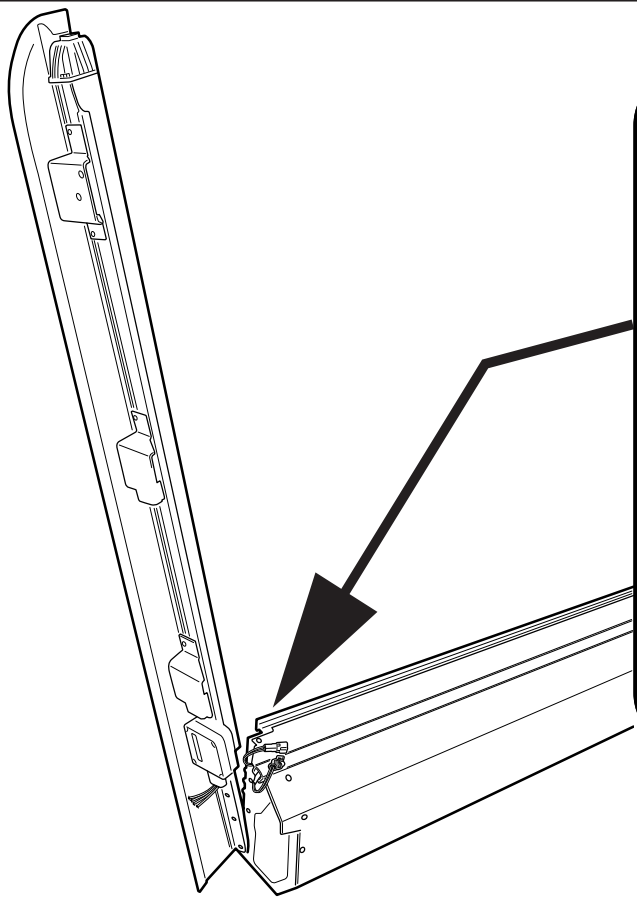

1. Using the retained screws, spring washer and washer, Loosely fasten the side rail to the location indicated.
2. Side rail edge must compress and meet with the canister profile as indicated below.
3. Fasten all screws tight.

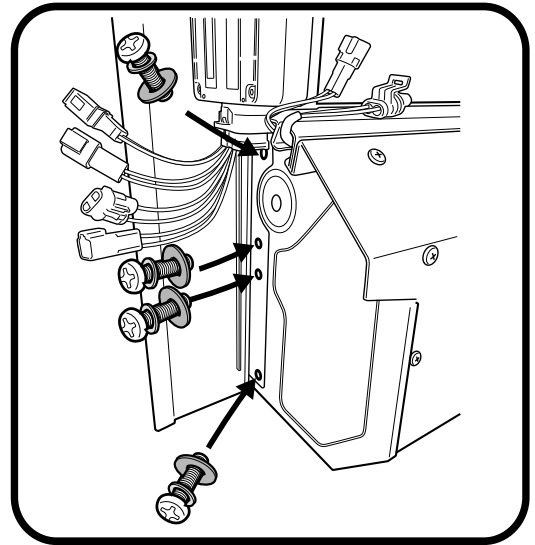
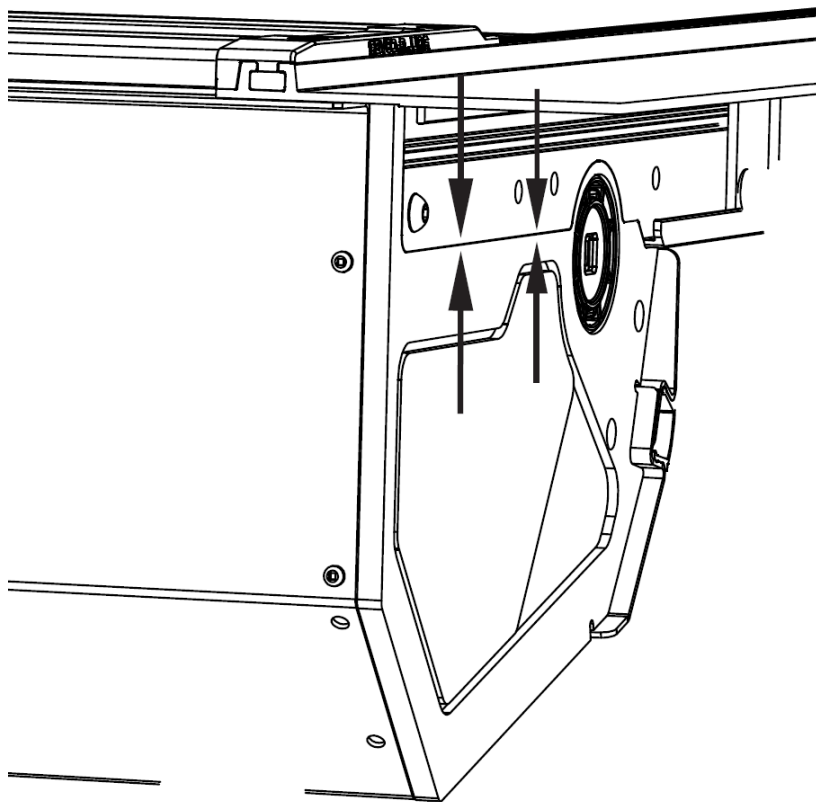
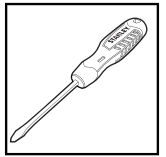

Connect motor connector to receiver

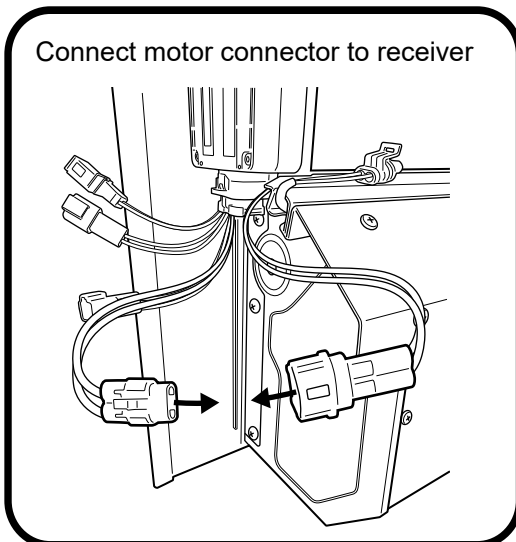

Connect LED Loom to receiver

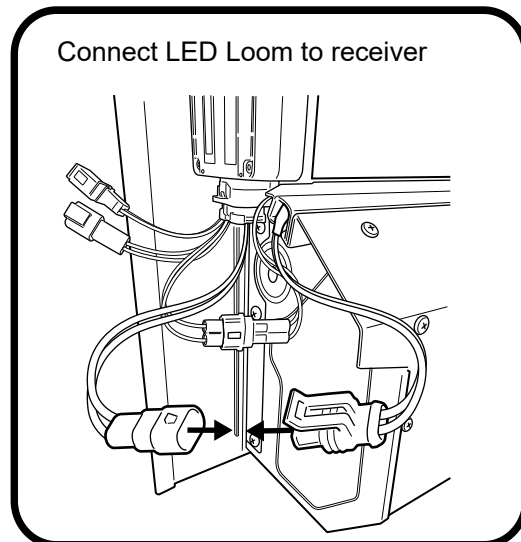



**Important Note:** Ensure that the Z seal within the track is positioned over the curtain and not folded inward. **WARRANTY** voided if assembled incorrectly.

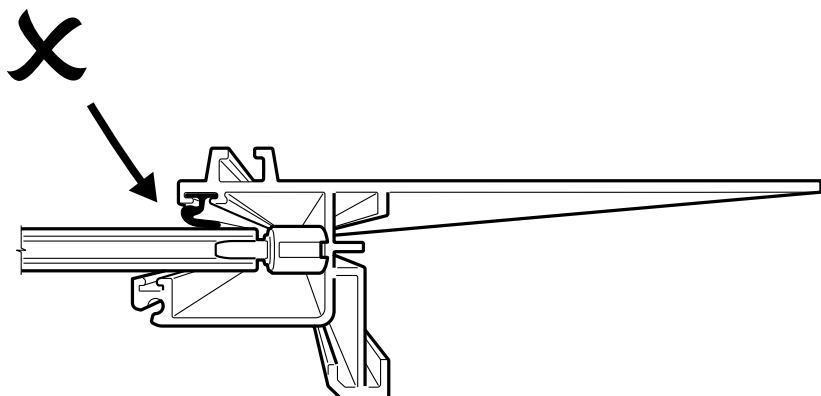
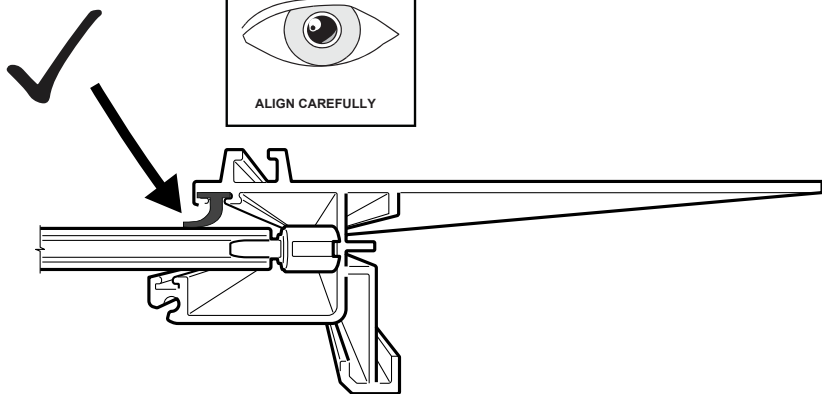

Align side rail to side of canister, guide the track to go in between the curtain end rubber stop.

NOTE: LHS side rail to be assembled first.

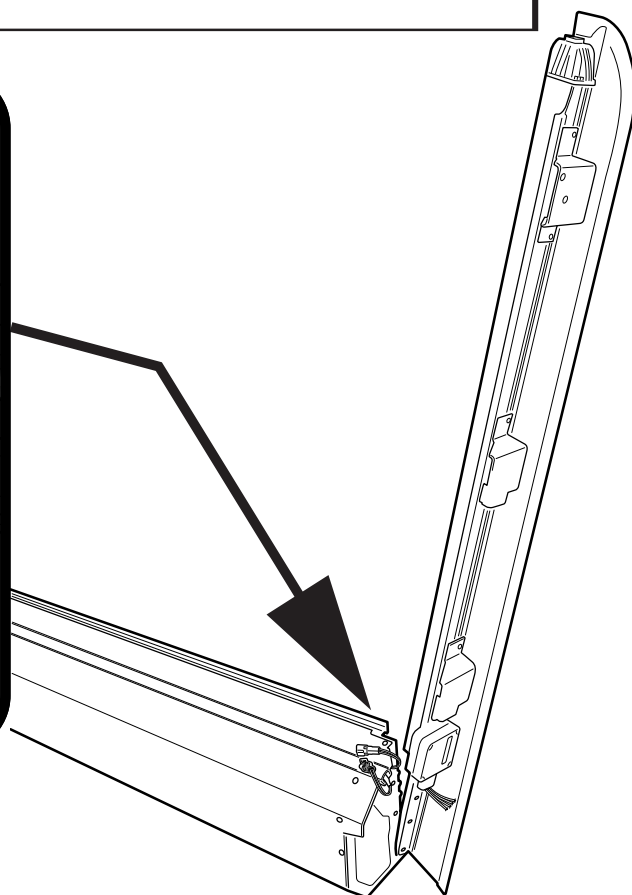
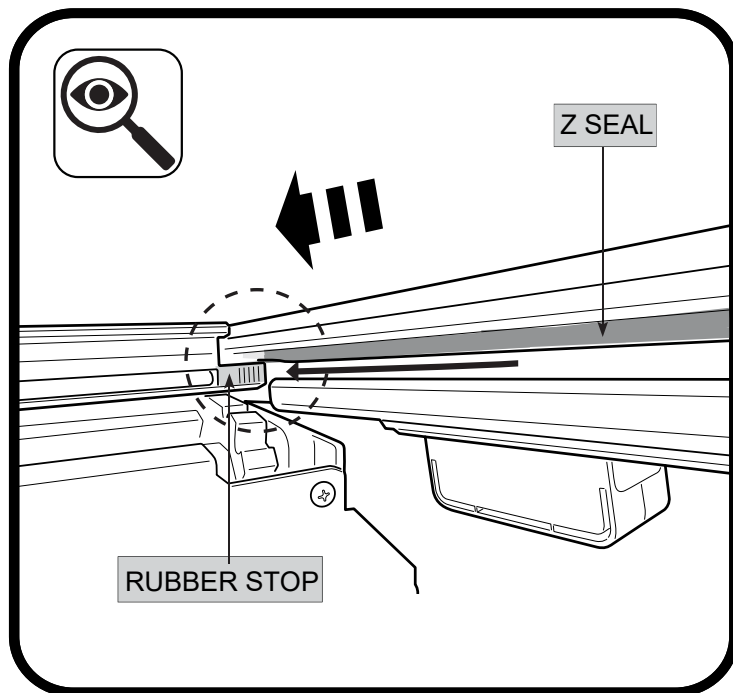

1. Using the retained screws, spring washer and washer, Loosely fasten the side rail to the location indicated.
2. Side rail edge must compress and meet with the canister profile as indicated below.
3. Fasten all screws tight.

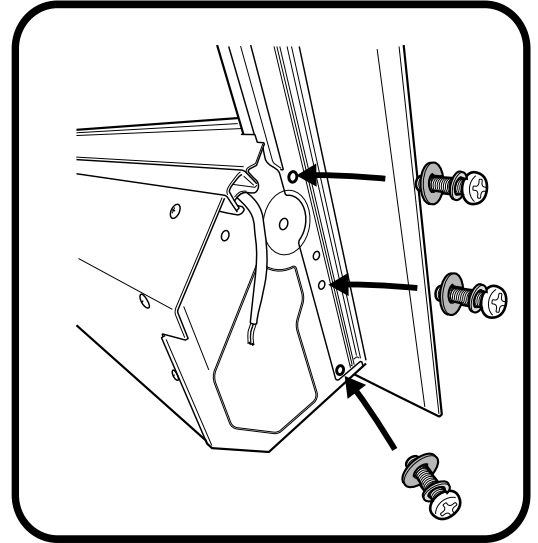
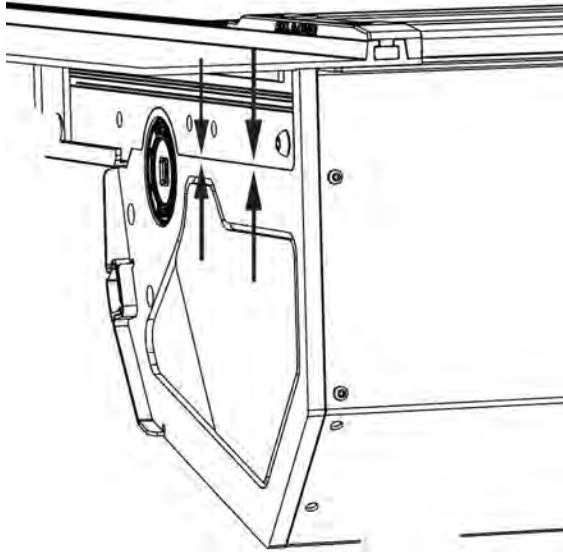
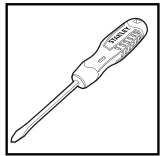

Feed M6 bolt through spring washer, motor and rubber bush.

**NOTE:** Rubber bush orientation has to be as per image. ( side with text on rubber, to face the motor).

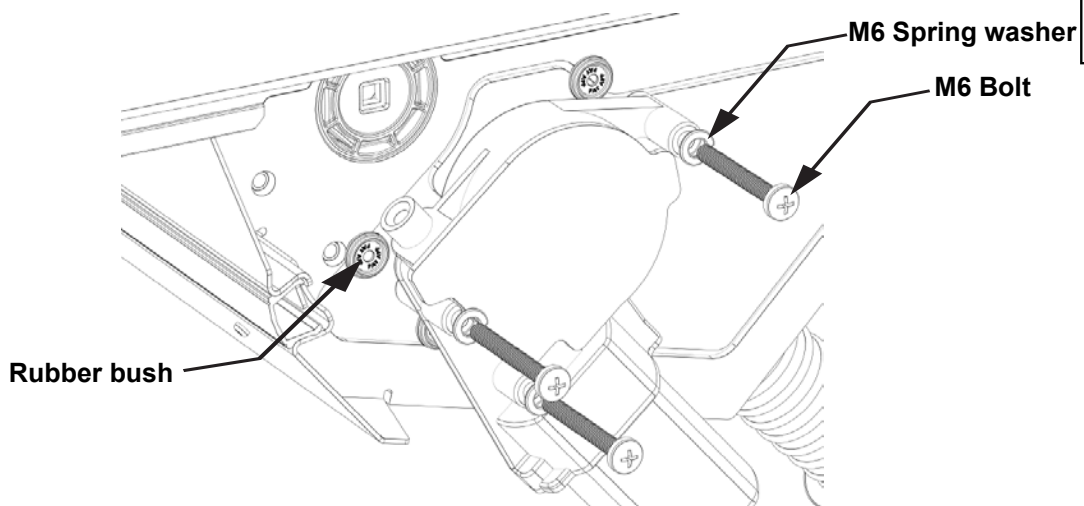
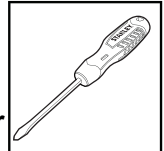

Align & insert motor shaft to axle.

**NOTE:** Pull / push curtain for axle to rotate.

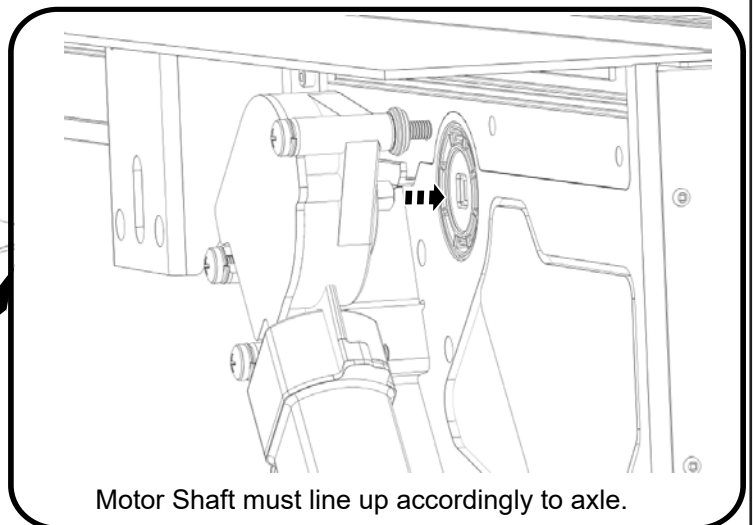
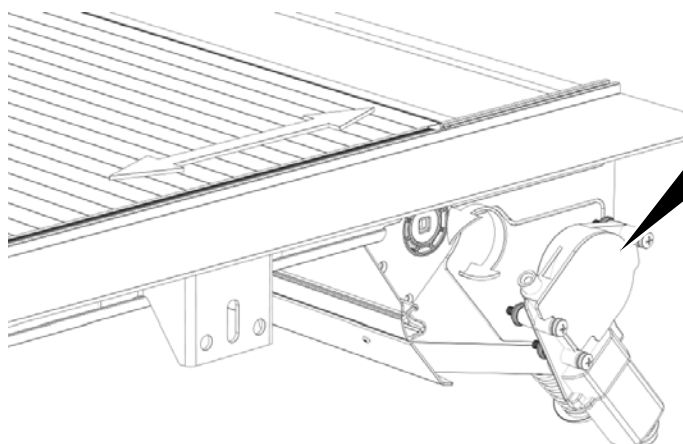

Fasten all 3 screws to 2nm torque. Over tensioning will cause operating issue's.

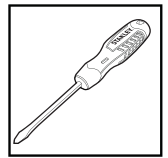
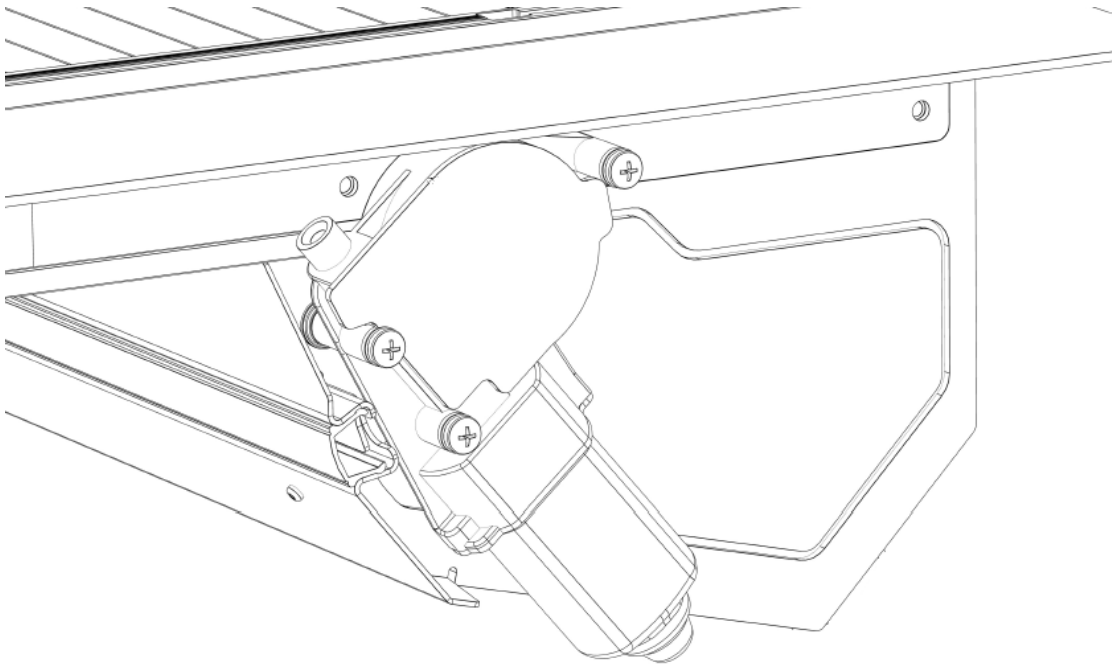

**Motor is to sit level.**

Any obstructions between motor and canister may cause operating issues.

Apply D-sponge foam tape to side rail as indicated. NOTE: Join foam firmly to the per-fitted foam of the canister. Carefully trim excess off & discard as indicated. Repeat on the other side.

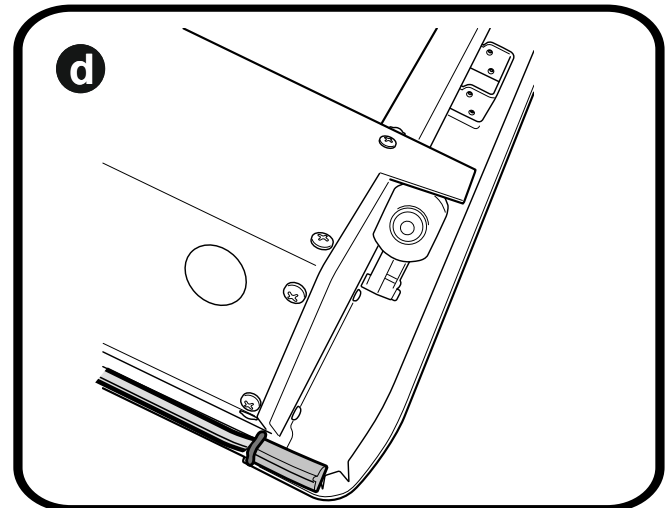
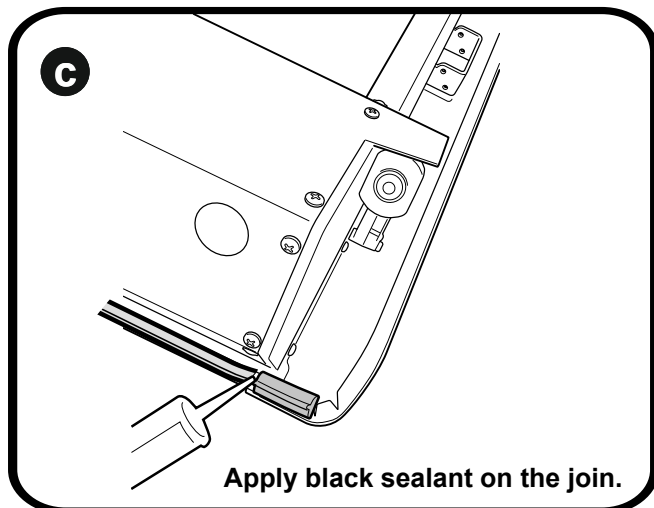
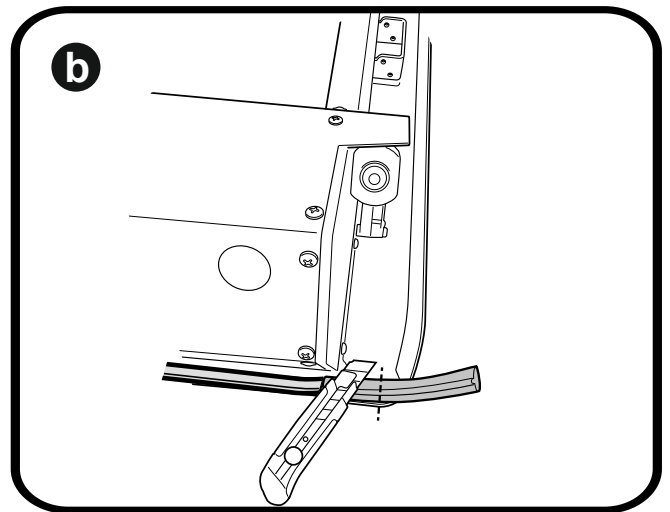
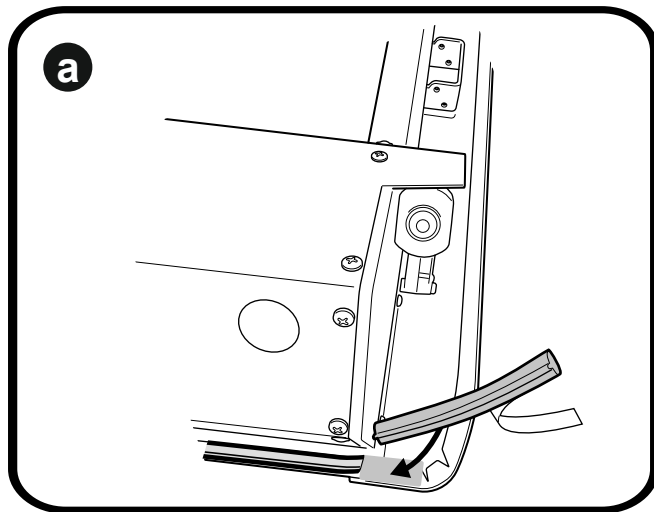

Carefully bring down the assembled unit.  
If side seal on the side rails has moved, carefully bring back into position.

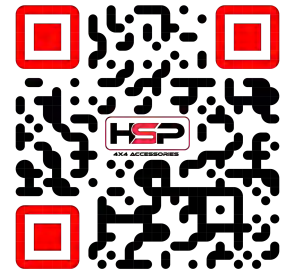
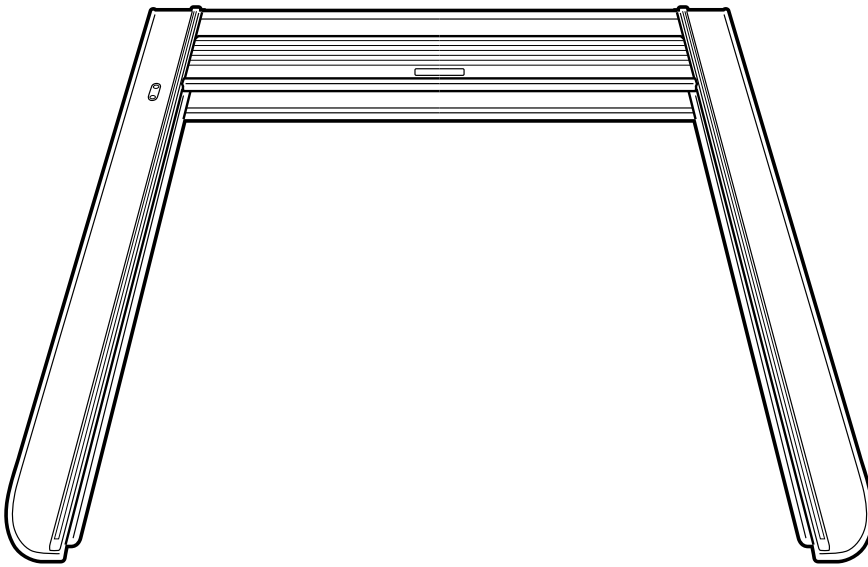

Insert side end caps to the top cover.

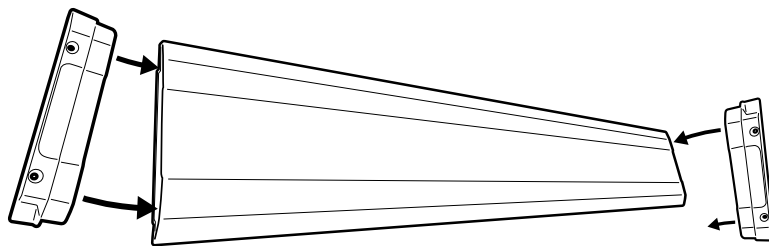
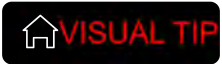
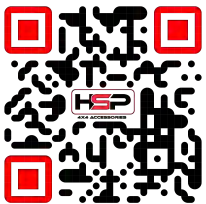

Place & Align top cover over the canister and side rails.

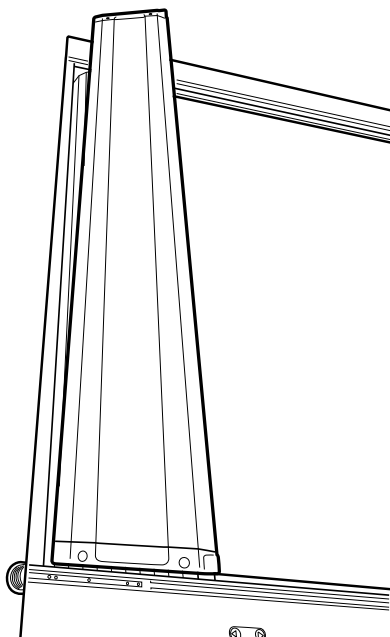

Using countersunk screws provided, line up end cap holes to the threads on the side rail.  
Fasten to 3nm torque. Repeat to the other side.

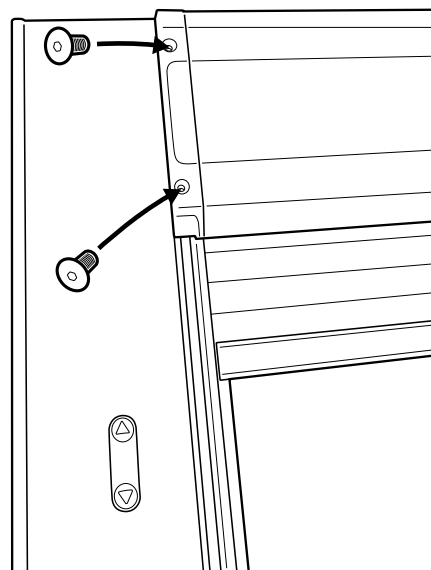

Place the Roll-R-Cover unit on to Ute bed.

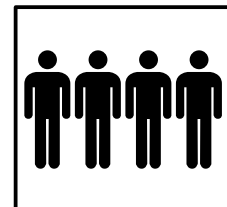
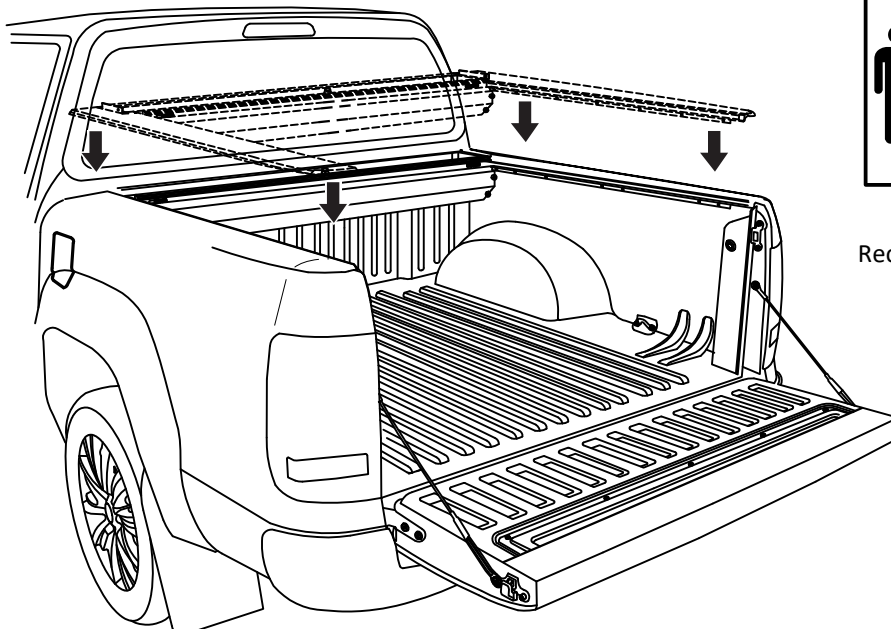

4 People  
Recommended for lift

With care, pull out any side rubber  
that has folded under the side rail.

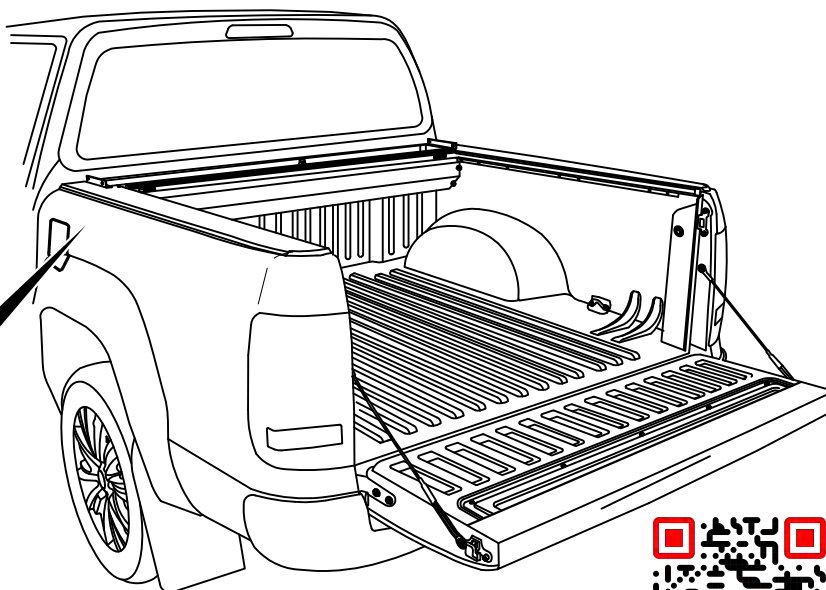
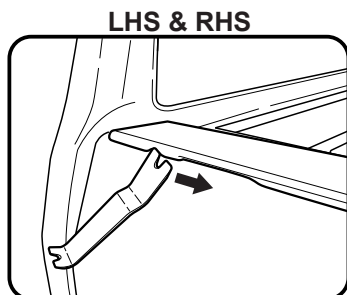



Passenger side: As indicated slide (S3.0-DC-AE-003 LH) rear Bracket into the channel of the side rail and push forward.  
**It is strongly recommended to scan the QR code and watch this step.**  
Repeat to the other side using S3.0-DC-AE-003 RH Bracket.

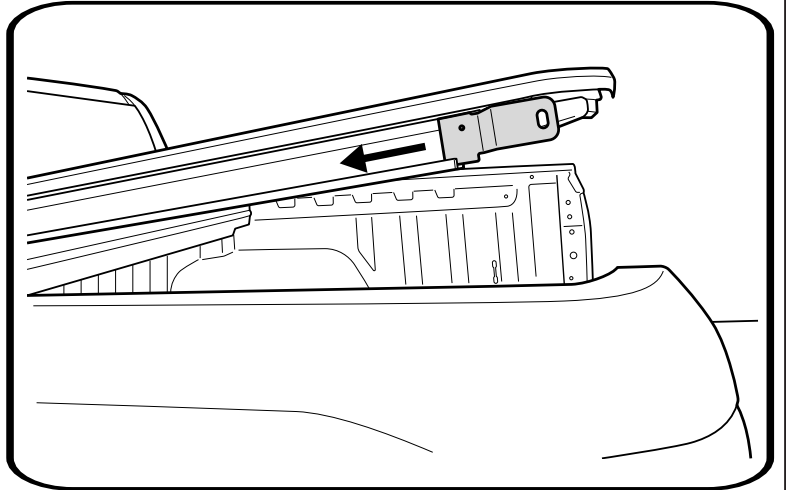
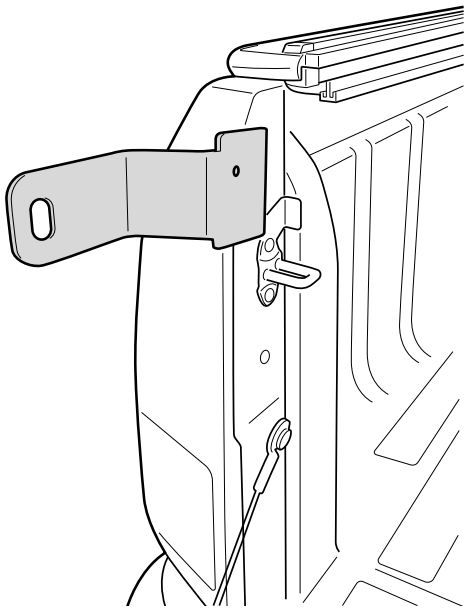
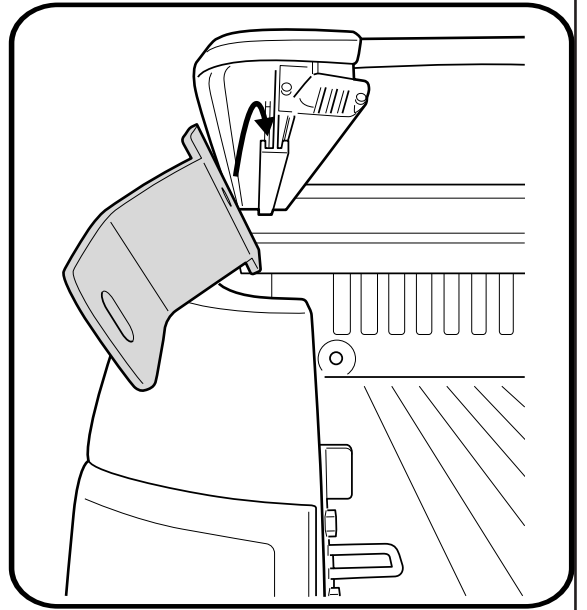
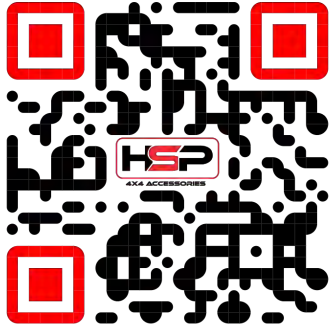

With care bring the side rail down onto the tub.  
Align the hole of the bracket to the thread of the tub.

Feed M8 x 20mm hex head bolt followed by M8 spring washer and M8 flat washer through bracket and loosely fasten to the thread of the ute bed.

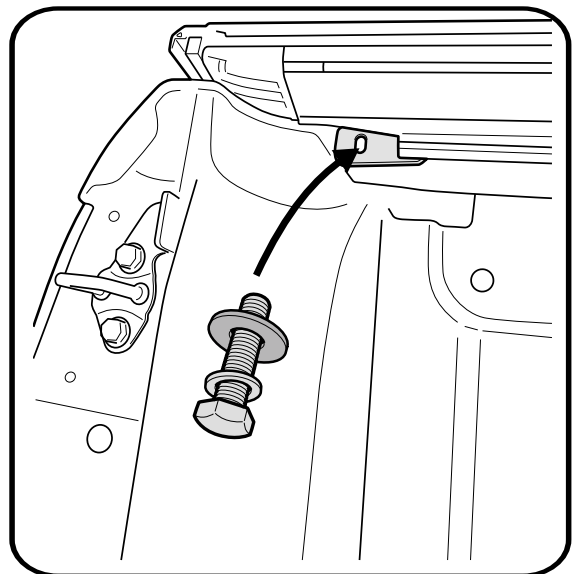
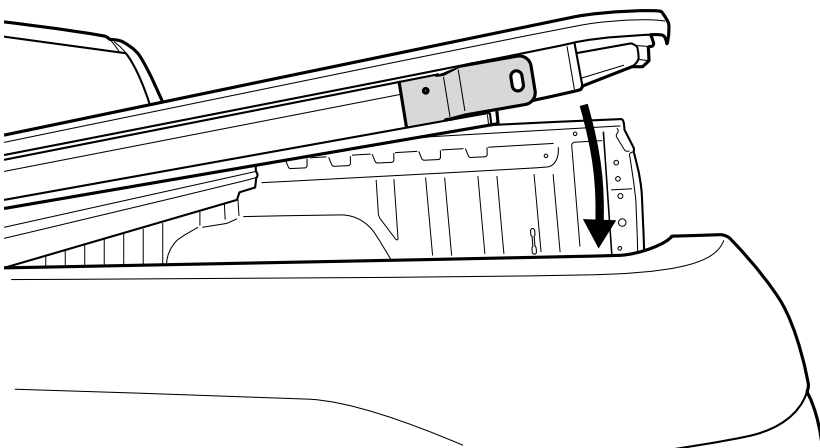

Position clamp behind the inner top lip of the bed rail and the center elongated hole of the side rail mounting brackets. Repeat to other side.

Ensure the M8 nut is in the indicated slot of the clamp

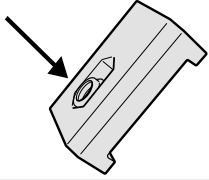

Fasten clamp loosely into position using M8 washer, M8 spring washer and M8 x 35mm bolt.

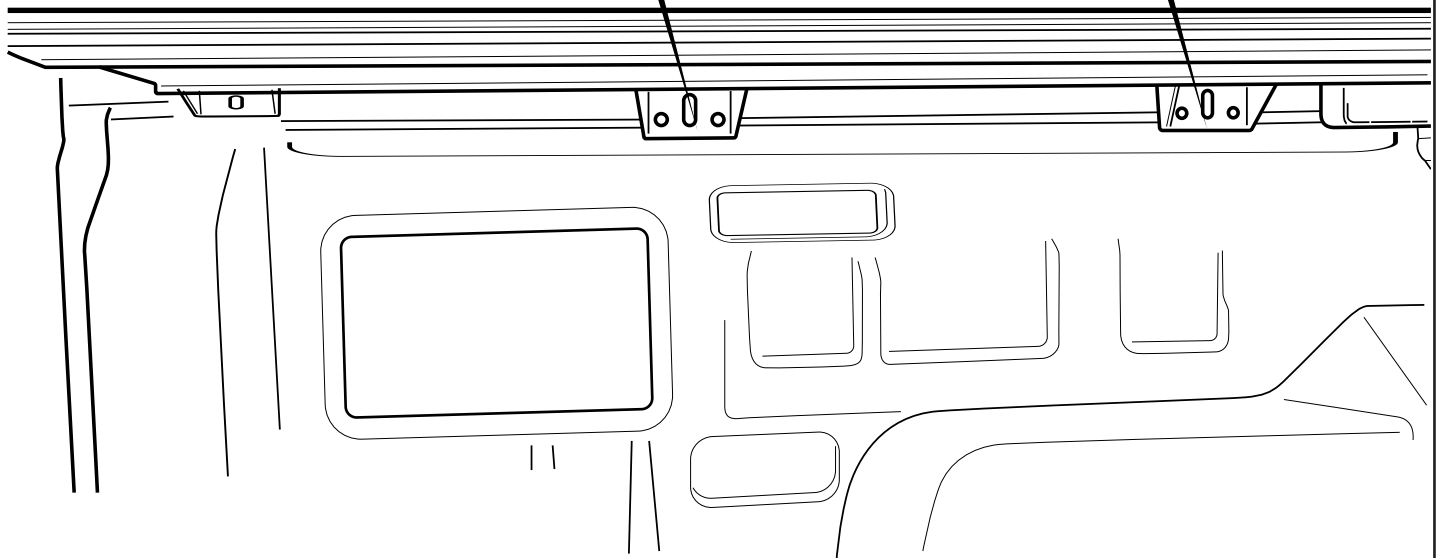
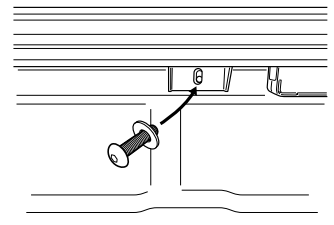

With the tailgate up (Closed position), Pull left & right hand side rails towards the tailgate, stopping short by 5mm between tailgate and side-rail end-cap. Repeat to other side.

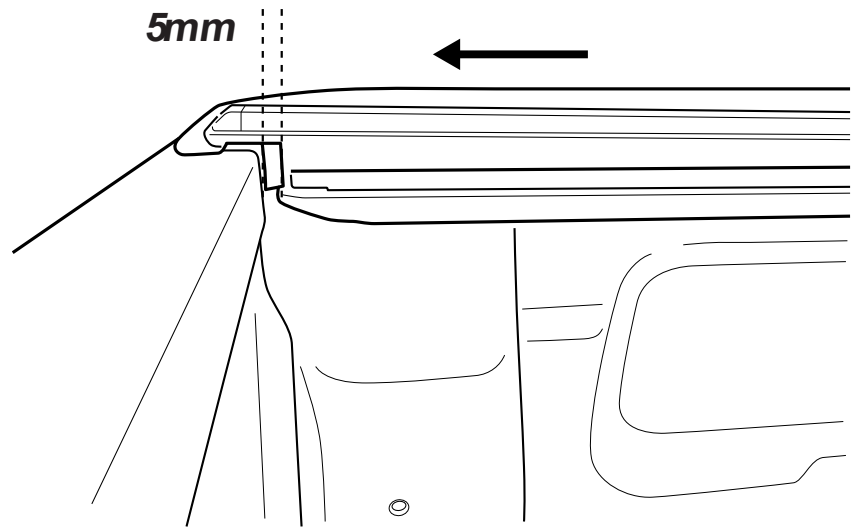

**Foam compressed to 5mm when tailgate is closed.**

Gap between tailgate and side-rail end cap to be 5mm.

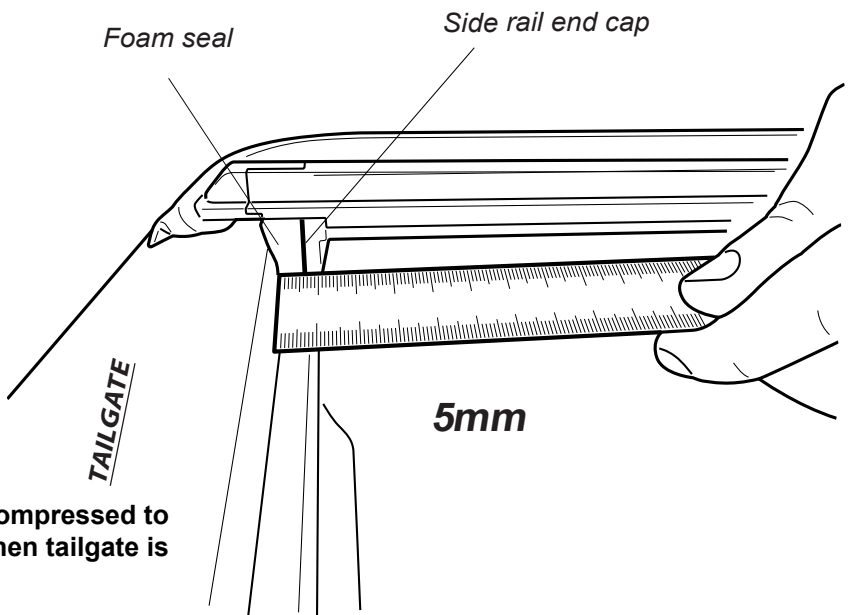

**Foam compressed to 5mm when tailgate is closed.**

1. Apply slight downward pressure on side rails.
2. Raise the clamp up so that the bottom of the clamp aligned to the center of the clamp bracket, then securely fasten the clamp in the specified order (A) and then (B) to a torque of 14Nm.

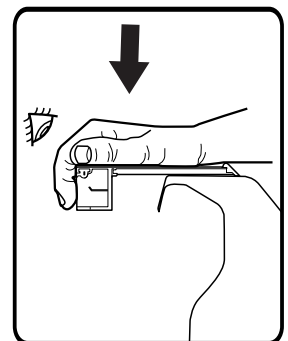
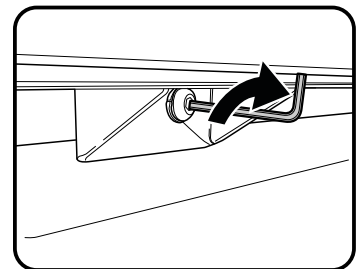
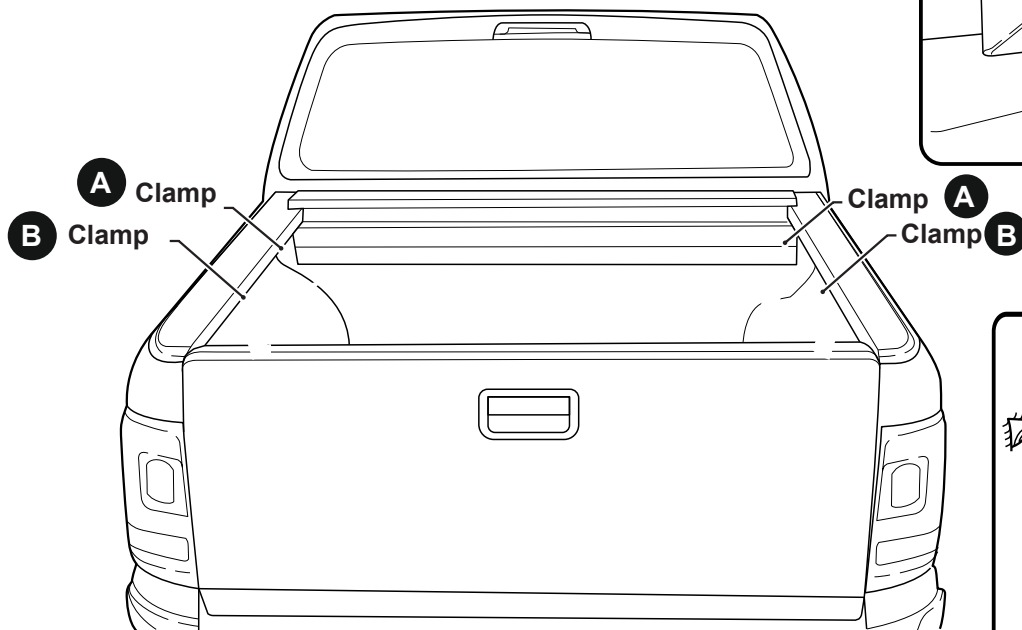

With the help of an assistant, apply gentle downward pressure to the side rail surface, causing slight compression of the outer side rail seal against the tub's top rail, while ensuring the side rail remains level. Next, securely tighten the indicated bolt to torque of 8Nm.

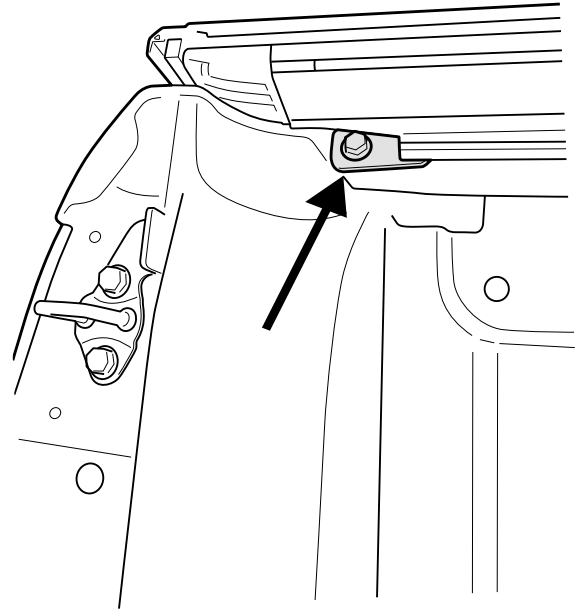
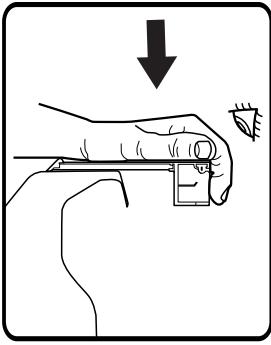

Side rail rubber to sit 1mm below from the top of the tailgate in the closed position. It is strongly recommended to scan the QR code and watch this step.

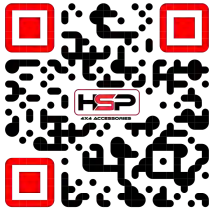

 VISUAL TIP

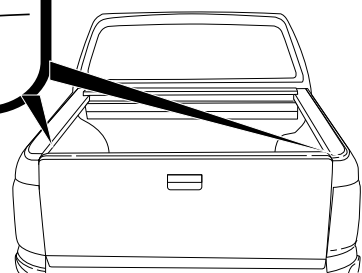
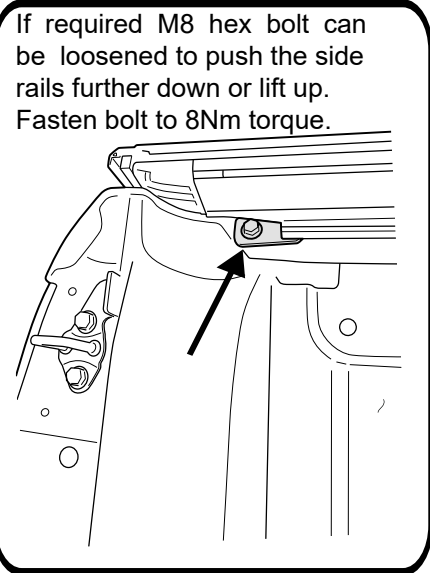
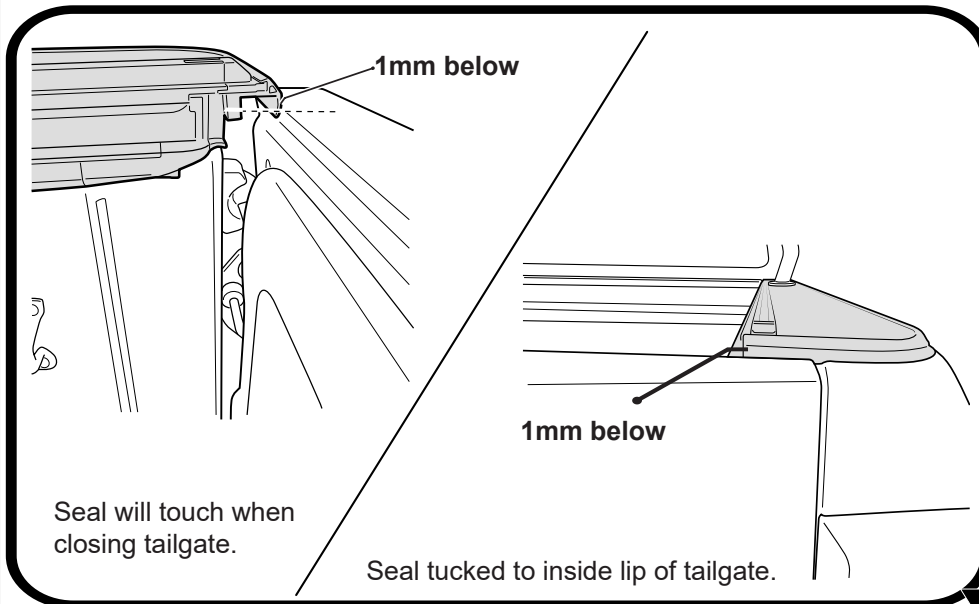

1. Clean area with non oil based cleaner, ie alcohol wipe.
2. Apply clear protective tape to left and right top corners of the tailgate as indicated.

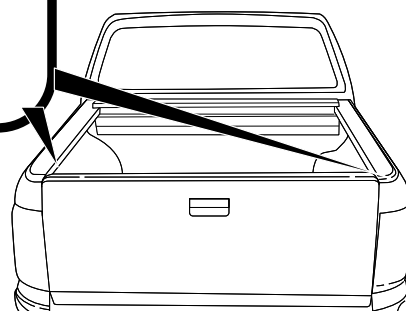
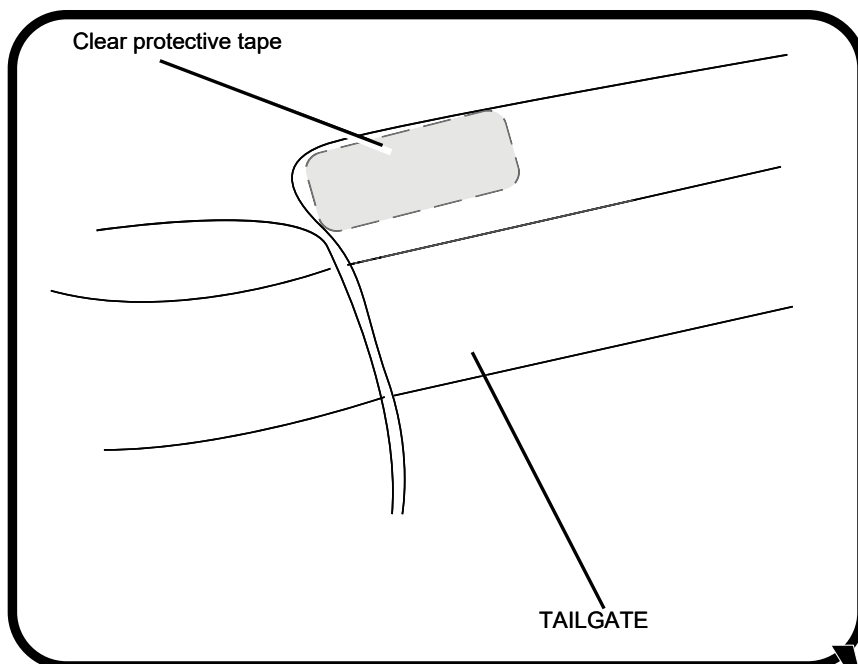
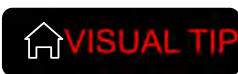

**Install front drain pipes through pre-drilled holes of the canister. ( RHS/LHS)**



Note: With care push tube in. Gently pull the tube back so it seals correctly against the front panel of the tub.



**VISUAL TIP**

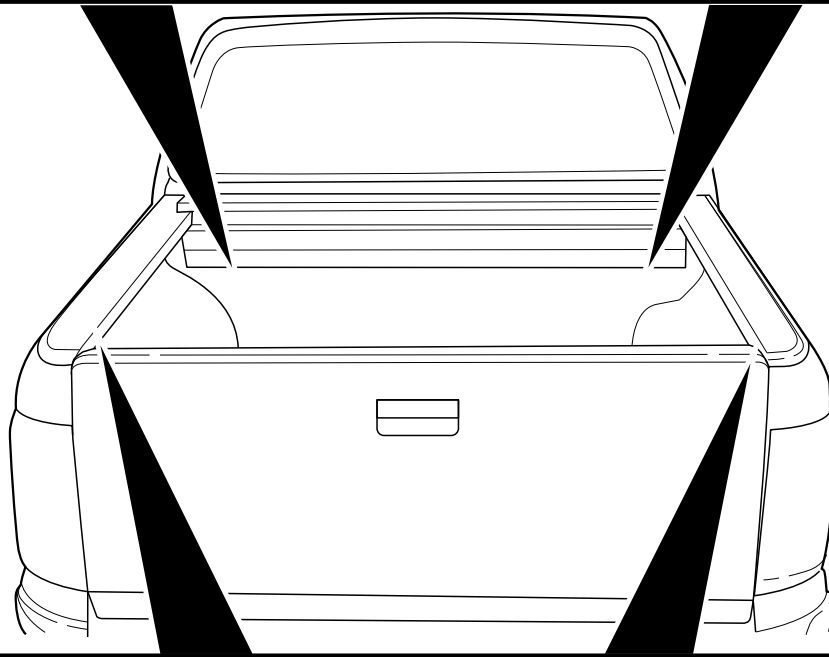
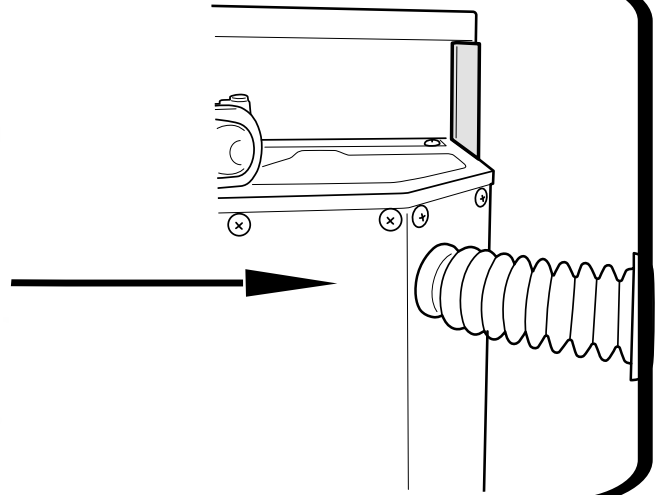
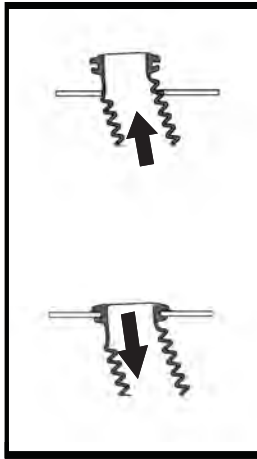

Note: With care push rear pipe in. Gently pull the pipe back so it seals correctly within the side rail channel.

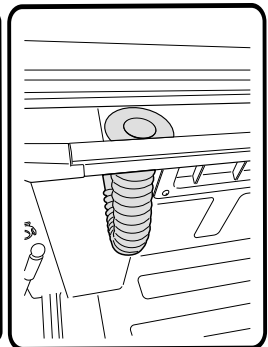
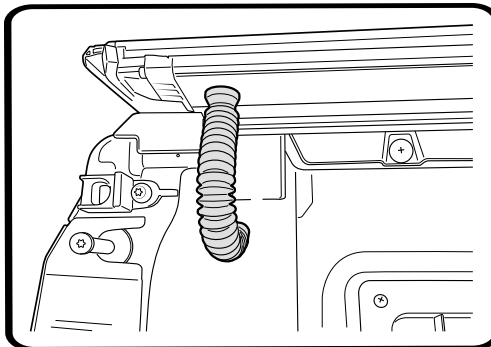
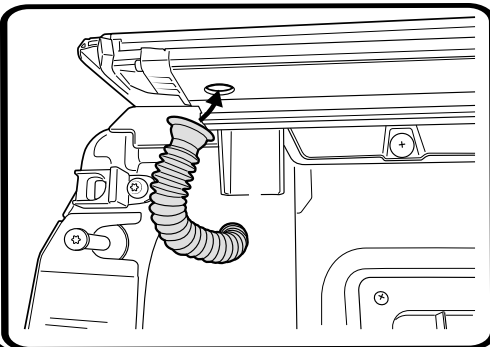
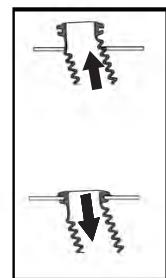

**Install rear drain pipes through pre-drilled holes of the siderails. ( RHS/LHS)**

- a. Connect Battery loom S2.75 to Receiver loom.
- b. **Carefully** connect S3-CL-PATCH to Receiver loom.



Align connectors carefully to avoid pushing pins out.

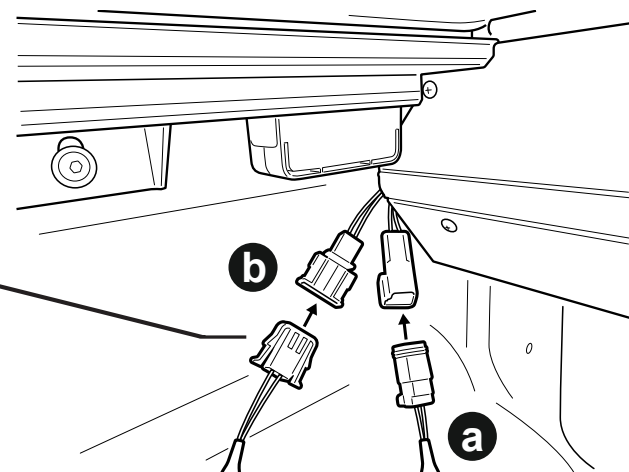

Carefully connect CI-Loom-Long to S3-cl-patch.

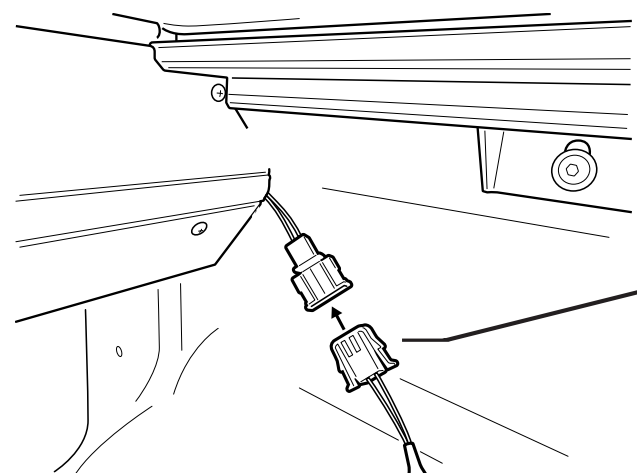

Align connectors carefully to avoid pushing pins out.



**Operating instructions:**

Press unlock on vehicle key fob to activate controller.  
 When vehicle is unlocked the side rail sensor buttons will be active to control.  
 When vehicle is locked the side rail sensor buttons will be inactive.

**Using factory key fob to operate:**

Pressing unlock twice on the factory key fob within 4 seconds, will activate the roll r cover to open.  
 Pressing lock twice on the factory key fob within 4 seconds, will activate the roll r cover to close.

**Vehicle proximity:**

Tapping the proximity twice to open or lock the car door will act exactly the same way as the key fob being pressed twice.

Touch & let go to open, touch & let go again to pause.

Touch & let go to close, touch & let go again to pause.

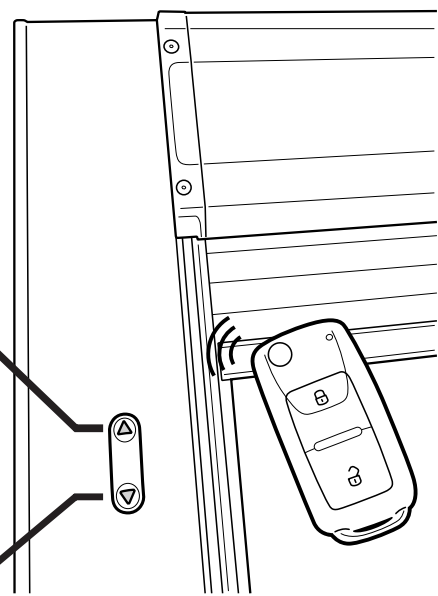

NOTE: 1. To wear in the Roll R Cover please fully open & close the cover approximately 15 times after install is complete.  
 2. Set your vehicle locking system to unlock all doors with one press of the factory remote unlock button. This setting can be found in your vehicle settings.

Trouble shooting visual tips:

side rail Parallel test

