



# INSTALLATION INSTRUCTIONS

**DS RAM 1500 CREW CAB  
SHORT BED 5'7"**



**INSTALLATION TIME:** 1 hours and 45 minutes (Approximately)

<b>IMPORTANT</b>	<ul style="list-style-type: none"> <li>• Do not stand/sit or rest heavy objects on Roll R Cover</li> <li>• Humans or animals are not to be under the closed cover at any given time</li> <li>• Tonneau Cover is not dust or water tight</li> <li>• If contact with volatile chemicals occur, clean Cover with mild detergent and water solution</li> </ul>			
<b>Care Instructions</b>	<ul style="list-style-type: none"> <li>• Read Instructions fully before commencing installation.</li> <li>• Clean Cover with a mild detergent and water solution</li> <li>• Do not use abrasive cleaners or solvents</li> <li>• Refer to manufactures instructions applicable to power drill.</li> <li>• Protect Tub floor against scratches during installation process.</li> </ul>			
<b>Maintenance</b>	Refer to Maintenance instructions.			
<b>Tools Required</b>	<table style="width: 100%; border: none;"> <tr> <td style="vertical-align: top;"> <ul style="list-style-type: none"> <li>• Pen / Marker</li> <li>• Centre Punch</li> <li>• Drill &amp; Drill bits</li> <li>• Caulking Gun</li> <li>• Silicon - Non Acetic</li> </ul> </td> <td style="vertical-align: top;"> <ul style="list-style-type: none"> <li>• Scissors &amp; Knife</li> <li>• Spanner &amp; Socket</li> <li>• Tape measure</li> <li>• Holesaw</li> <li>• Filing tool</li> </ul> </td> <td style="vertical-align: top;"> <ul style="list-style-type: none"> <li>• Soapy water solution</li> <li>• Allen Key set</li> <li>• Screw driver</li> <li>• Rust Inhibitor</li> <li>• Trim Removal Tool</li> </ul> </td> </tr> </table>	<ul style="list-style-type: none"> <li>• Pen / Marker</li> <li>• Centre Punch</li> <li>• Drill &amp; Drill bits</li> <li>• Caulking Gun</li> <li>• Silicon - Non Acetic</li> </ul>	<ul style="list-style-type: none"> <li>• Scissors &amp; Knife</li> <li>• Spanner &amp; Socket</li> <li>• Tape measure</li> <li>• Holesaw</li> <li>• Filing tool</li> </ul>	<ul style="list-style-type: none"> <li>• Soapy water solution</li> <li>• Allen Key set</li> <li>• Screw driver</li> <li>• Rust Inhibitor</li> <li>• Trim Removal Tool</li> </ul>
<ul style="list-style-type: none"> <li>• Pen / Marker</li> <li>• Centre Punch</li> <li>• Drill &amp; Drill bits</li> <li>• Caulking Gun</li> <li>• Silicon - Non Acetic</li> </ul>	<ul style="list-style-type: none"> <li>• Scissors &amp; Knife</li> <li>• Spanner &amp; Socket</li> <li>• Tape measure</li> <li>• Holesaw</li> <li>• Filing tool</li> </ul>	<ul style="list-style-type: none"> <li>• Soapy water solution</li> <li>• Allen Key set</li> <li>• Screw driver</li> <li>• Rust Inhibitor</li> <li>• Trim Removal Tool</li> </ul>		

**PERSONAL PROTECTIVE EQUIPMENT:**



Rubber Gloves



Goggles



Hearing Protection

# BOX CONTENTS

**LEFT & RIGHT SIDE RAIL**

S2.5-DC-AE-002ps-DS4R 

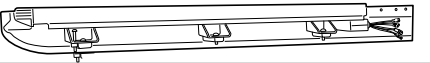
S2.5-DC-AE-003ds-DS4R 



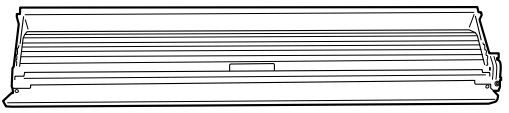





**CANISTER ASSEMBLY**

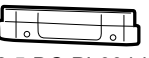



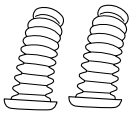
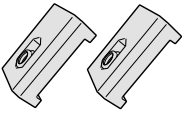
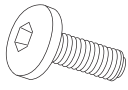

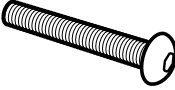
S3-XC-AF-001/002\_DS4

**CANISTER TOP COVER**  **S2.5-DC-AE-005 -RT**

## SPECIFIC KIT RT4

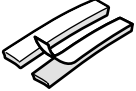
<p><b>COVER END CAPS</b></p>  <p>S2.5-DC-PI-004ps</p>  <p>S2.5-DC-PI-004ds</p>	 <p><b>COUNTERSUNK SCREW Qty - 4</b></p>	 <p><b>FLAT PLATE Qty- 2</b></p>	 <p><b>CABLE TIE Qty x 16</b></p>	 <p><b>BATTERY LOOM S2.75</b></p>	 <p><b>Drainage pipe Qty - 2</b></p>
 <p><b>SIDERRAIL CLAMP Qty - 6</b></p>	 <p><b>M8 x 35mm Qty - 6</b></p>	 <p><b>M8 WASHER Qty - 6</b></p>	 <p><b>M8 SPRING WASHER Qty - 6</b></p>	 <p><b>M8 x 90 mm Qty - 2</b></p>	 <p><b>M8 NUT Qty - 8</b></p>
 <p><b>Rear Drainage pipe Qty - 2</b></p>					

## SPECIFIC KIT DT

 <p><b>50449 D-SPONGE Qty-2</b></p>	 <p><b>CL-LOOM-LONG</b></p>	 <p><b>DT-PATCH</b></p>	 <p><b>Foam seal Qty - 1.7m</b></p>	 <p><b>3M PRIMER</b></p>
--	--	--	--	---

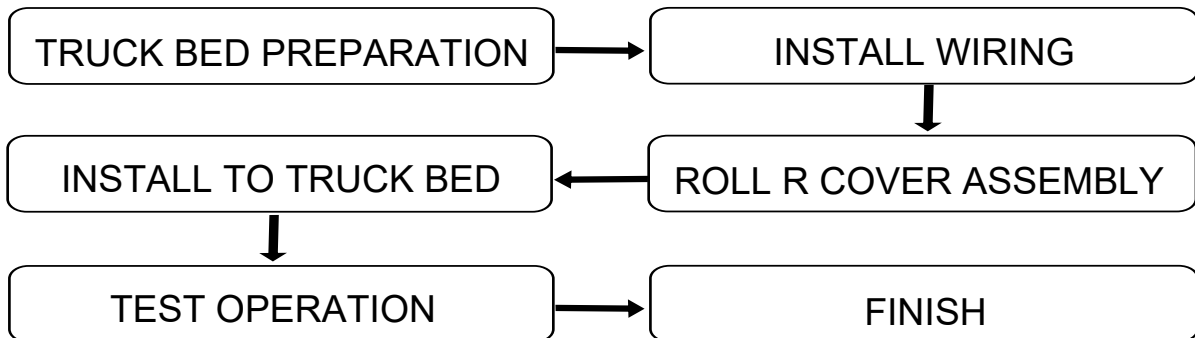

Clean are as indicated.

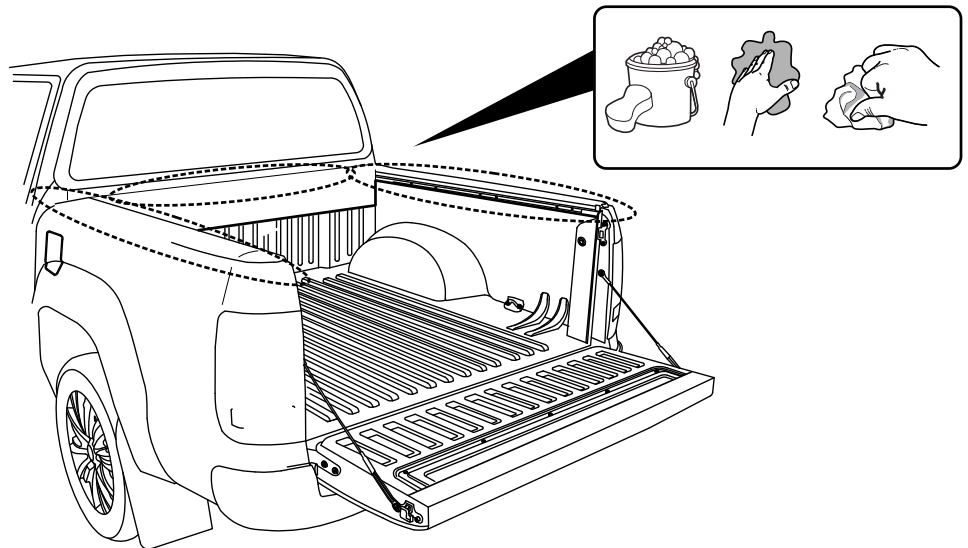

Measure down from top of headboard 250mm & 150mm from inside wall of bed as shown.  
Repeat to the other side.  
Using a 30mm hole-saw drill through tub front panel, file away any sharp edges. Apply anti rust coating. Repeat to other side.

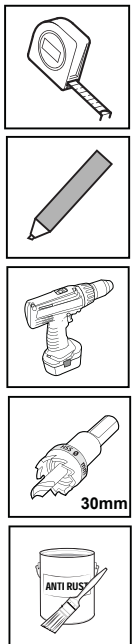
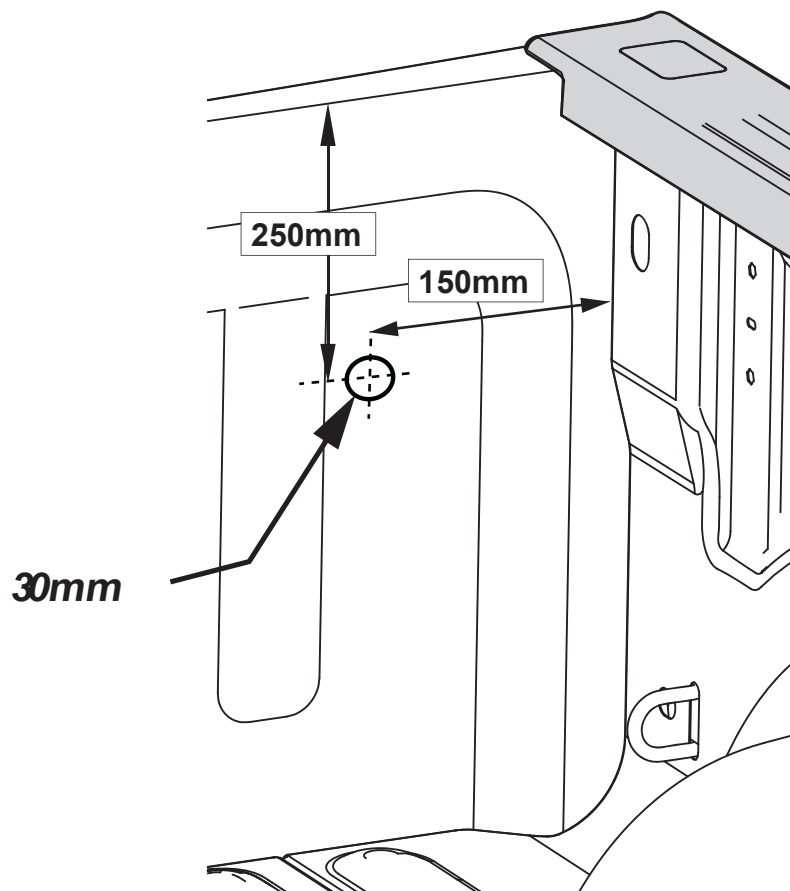

 **ATTENTION:** Do not exceed 30mm hole.

Carefully unpack the box.

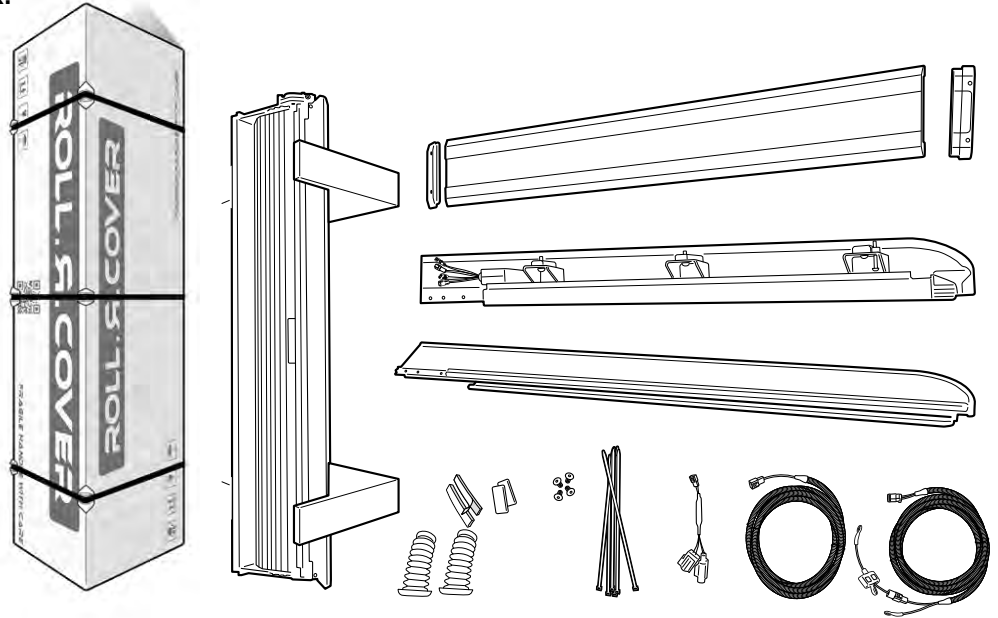

1. Apply 3m primer to the top of head board as indicated.
2. Run foam seal provided along the front ( inside edge towards tailgate) of the tub to make head-rail level with sides.

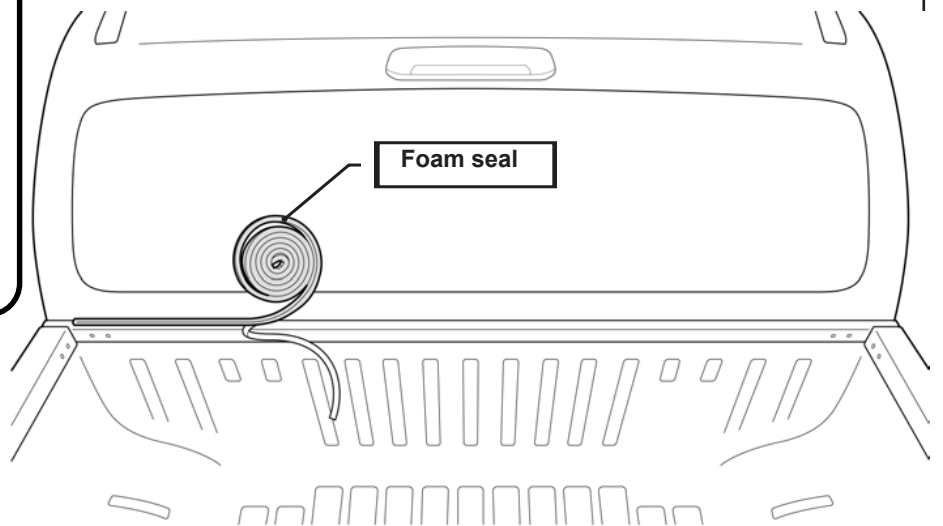
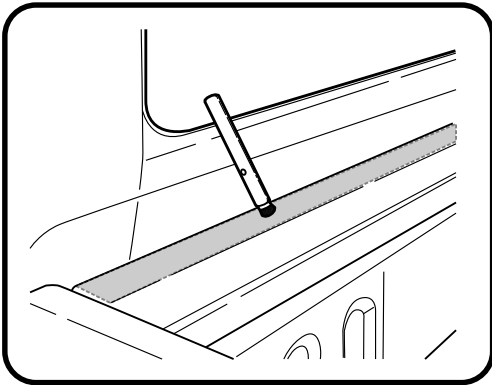

Install front drain pipes ( 55mm diameter end of hose) through pre-drilled holes on the front tub panel.

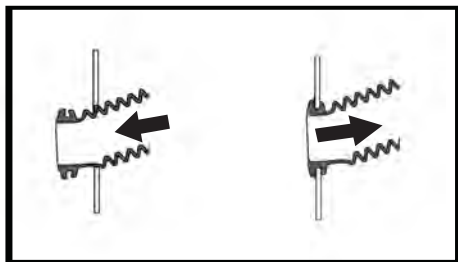

Note: With care push tube in.  
Taking care pull the tube back so it seals correctly against the front panel of the tub.

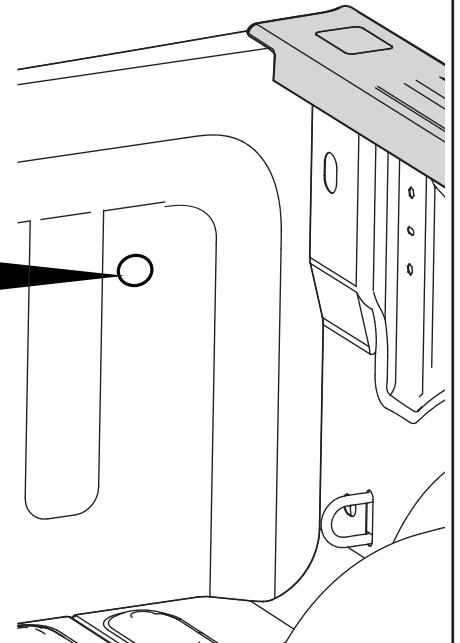

Remove and retain tail lights.

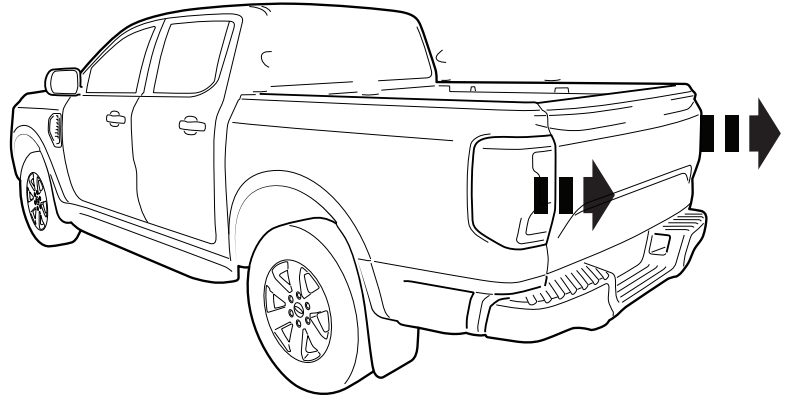

Measure 90mm towards the front of tub from the edge of the pillar as indicated. Measure down 50mm from the top edge of the tub as directed and make a mark. Use a 15mm hole-saw to drill through the tub pillar, and file away any sharp edges. Apply an anti-rust coating. Repeat the same steps on the other side.

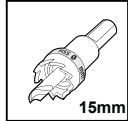
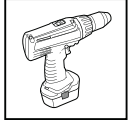
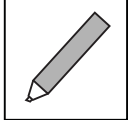
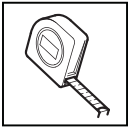

**ATTENTION:** Do not exceed 15mm hole.

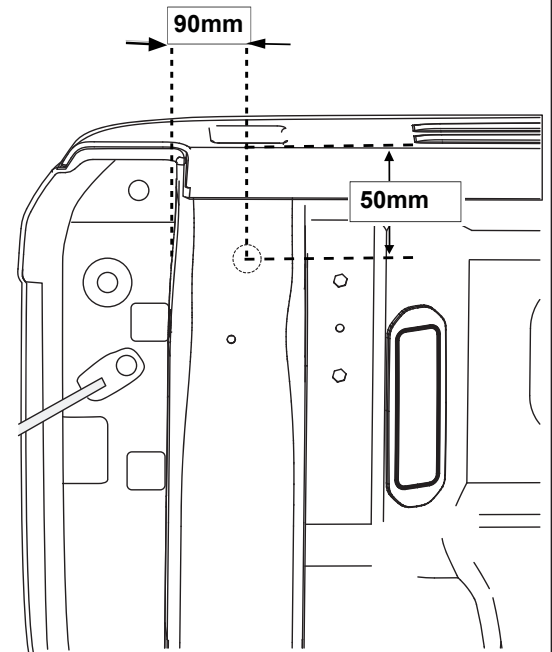

- a** In the specified orientation insert the rear drainage pipe into the previously drilled hole.
  - b** Leaving 150mm of the pipe hanging out.
  - c** Check the tail light cavity to ensure there are no obstructions to the drainage pipe. Repeat to the other side.
- Re-fit the tail lights.

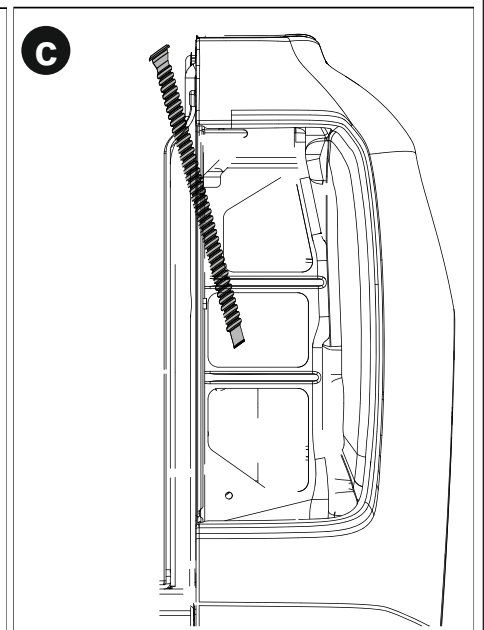
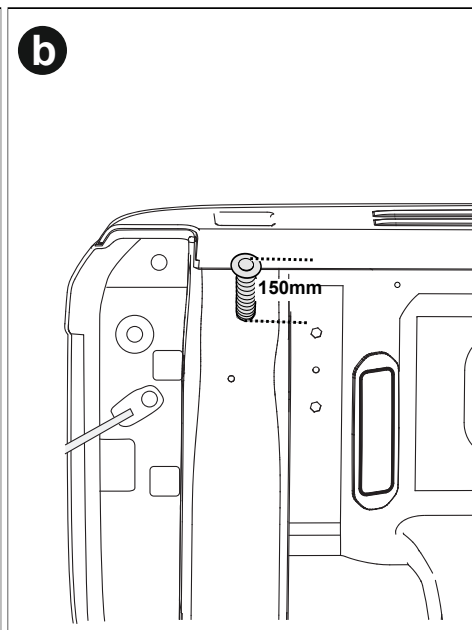
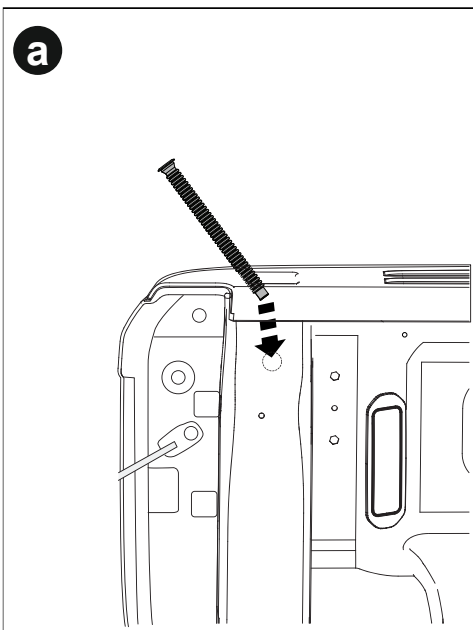

Disconnect fuse patch from battery loom S2.75.

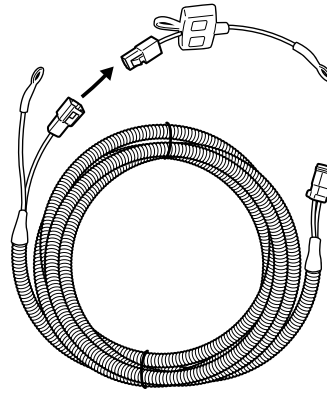

### Wiring Harness steps

- 1 Locate the front left factory hole on the side wall of the tub, remove grommet and feed battery loom through the hole.

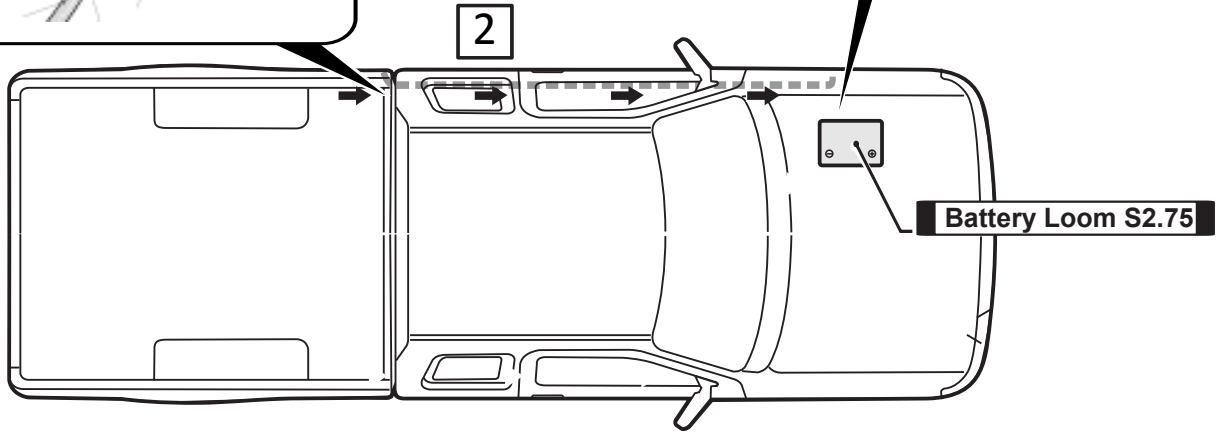
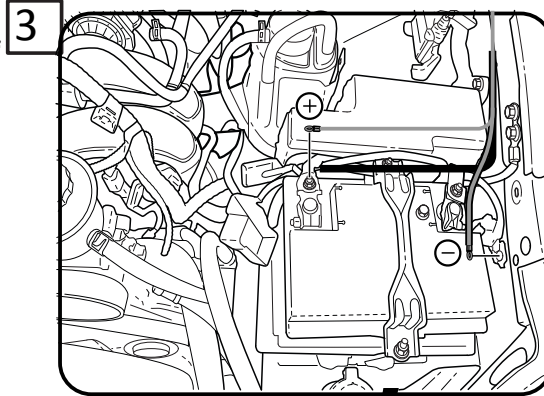
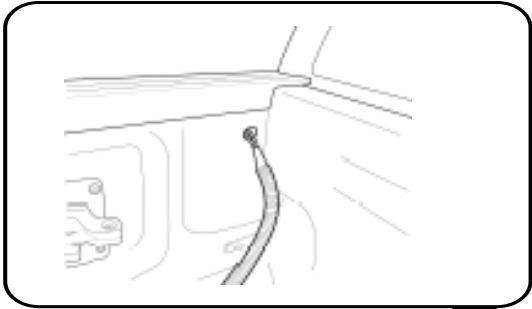

Run the wiring from the front of tub side wall ( leaving 200mm in the tub) to the battery over the chassis rail. Making sure to keep away from hot obstructions and cable tie every 400mm. Reconnect fuse patch to battery loom S2.75, now attach fuse patch to positive of battery and earth to the body of the Ute.

Feed CL-LONG-Loom through the same hole used for battery loom.

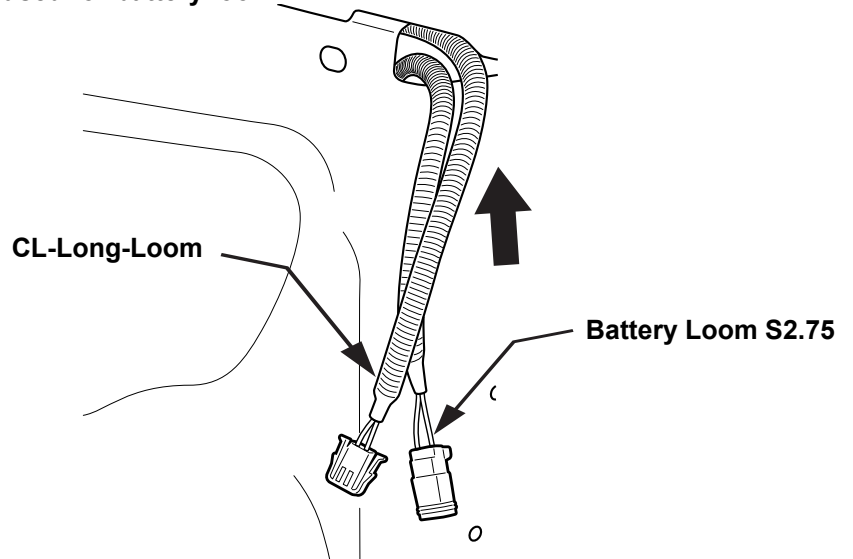

Run wiring from to passenger side B pillar Cable tie wiring every 500mm over chassis rail. Locate floor grommet under the front passenger seat, make a small incision & run the loom through it to enter the cab and towards B pillar. Seal accordingly.

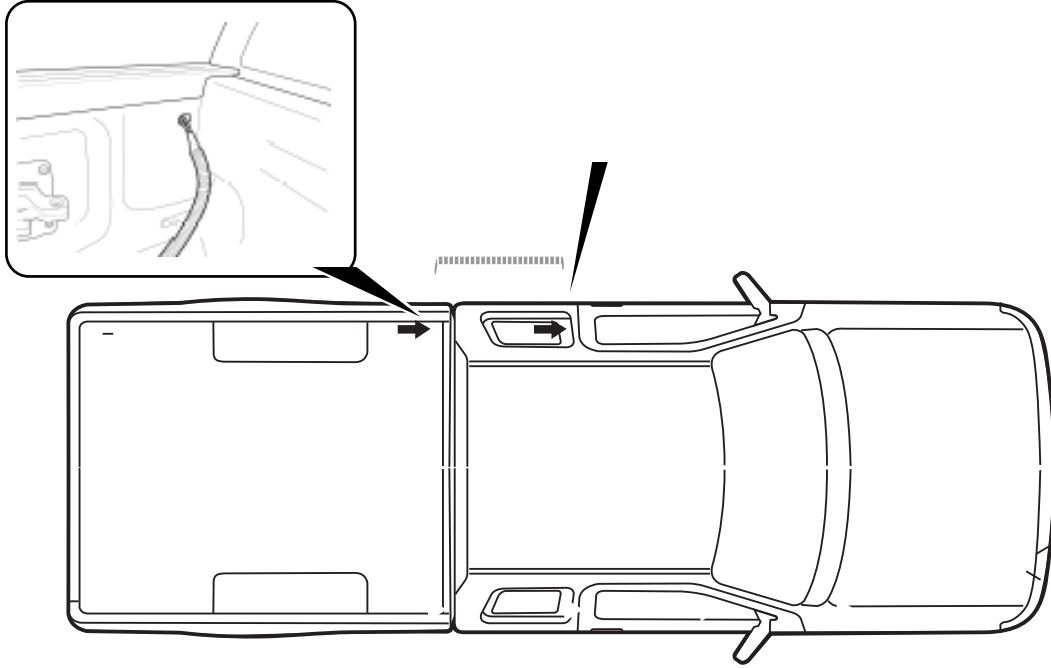

Remove B pillar trim as indicated.

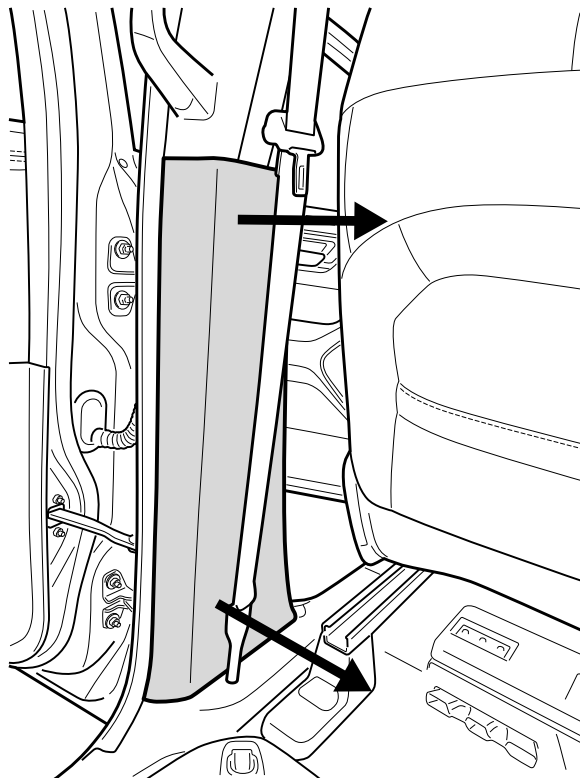

Disconnect the indicated plug.

DISCONNECT CONNECTOR

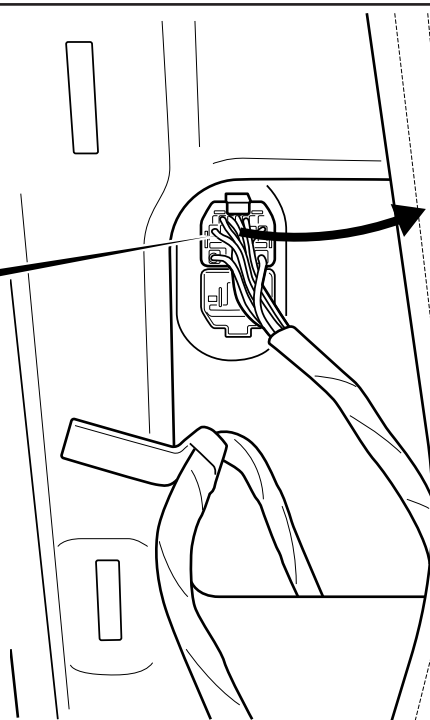

Connect DT-PATCH to the vehicle harness.

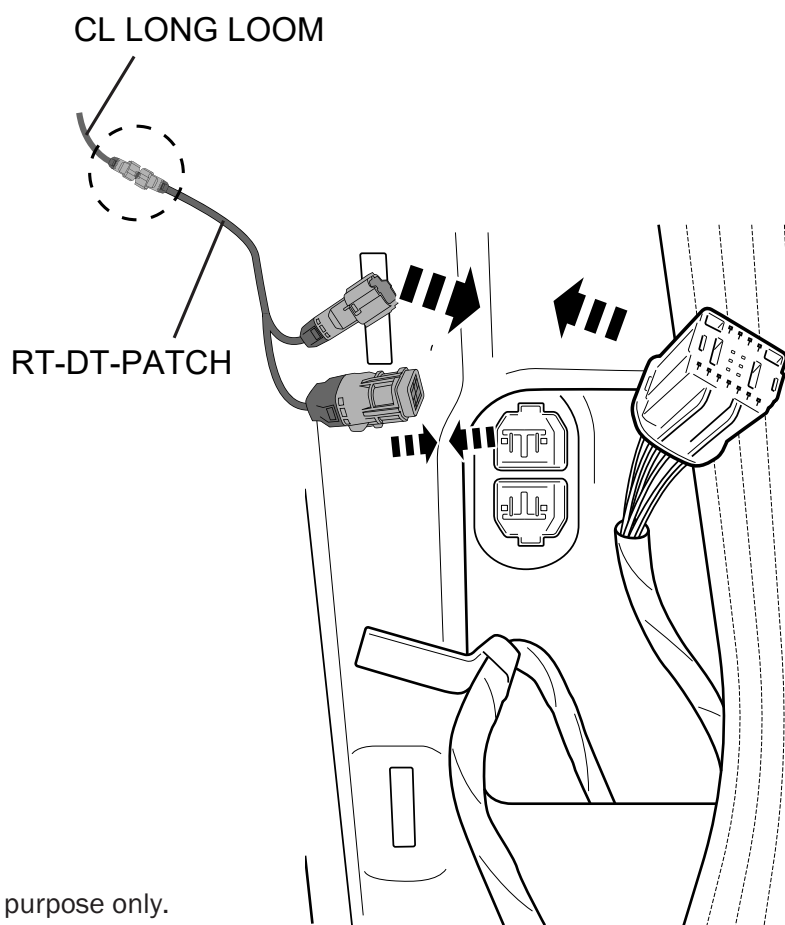

NOTE: image used is for illustration purpose only.

RE-ASSEMBLE ANY REMOVED TRIMS.



keep the cannister in the foam blocks from the packaging for assembly.

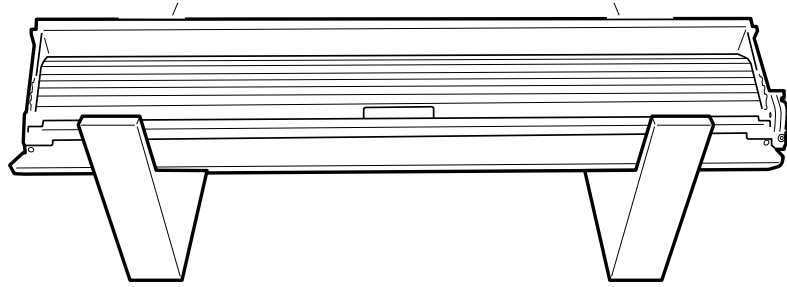

With assistance turn the canister on its back on the foam blocks.

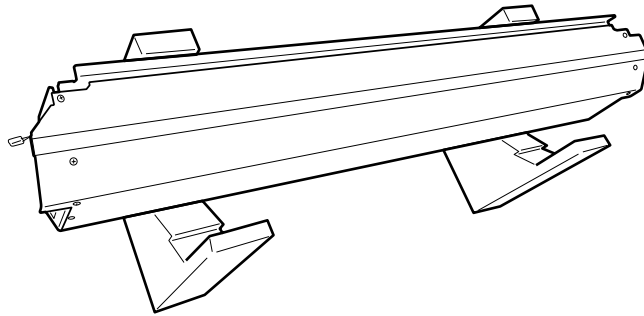

Disengage motor from the axle by unfastening the 3 Screws as indicated. Retain all parts.

Remove and retain the 3 screw from the canister as indicated.

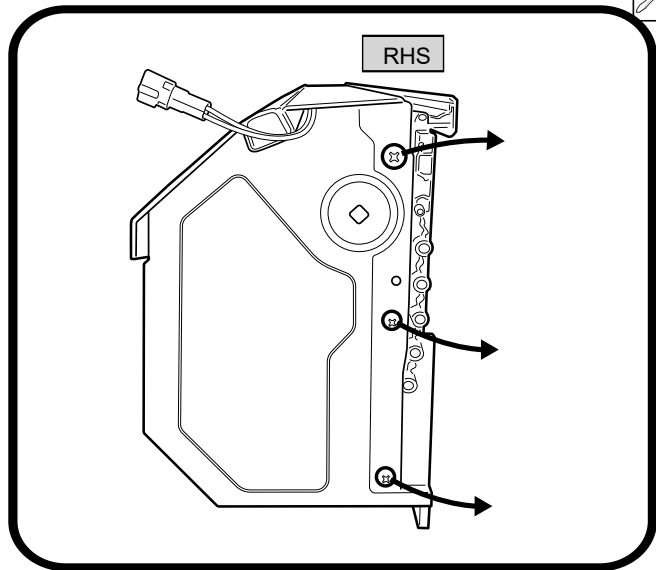
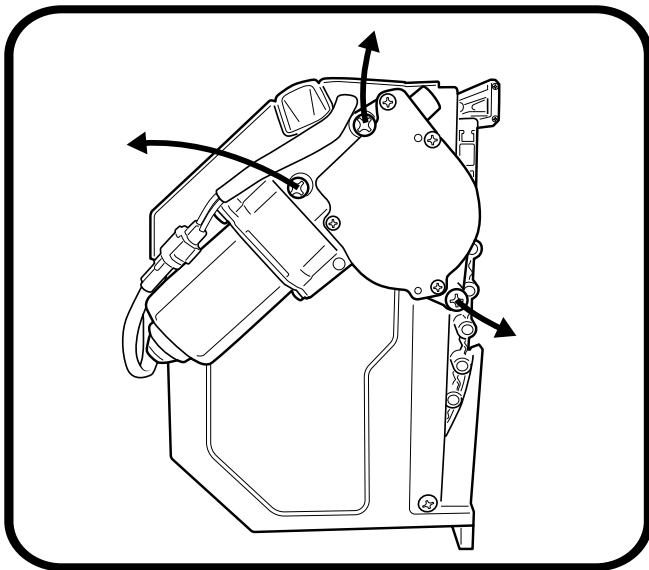

Now on the other side, remove and retain the 4 screws from the canister as indicated.

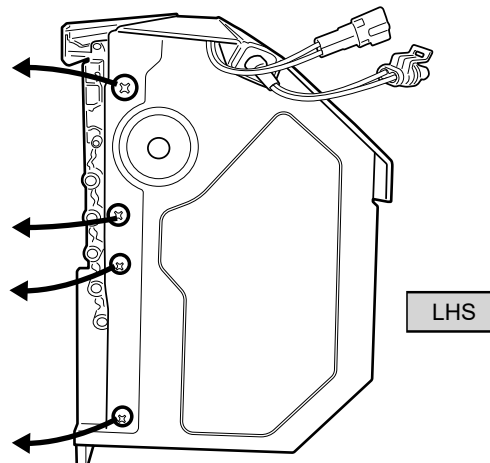
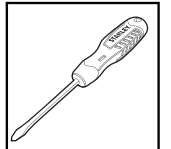



**Important Note:** Ensure that the Z seal within the track is positioned over the curtain and not folded inward. **WARRANTY** voided if assembled incorrectly.

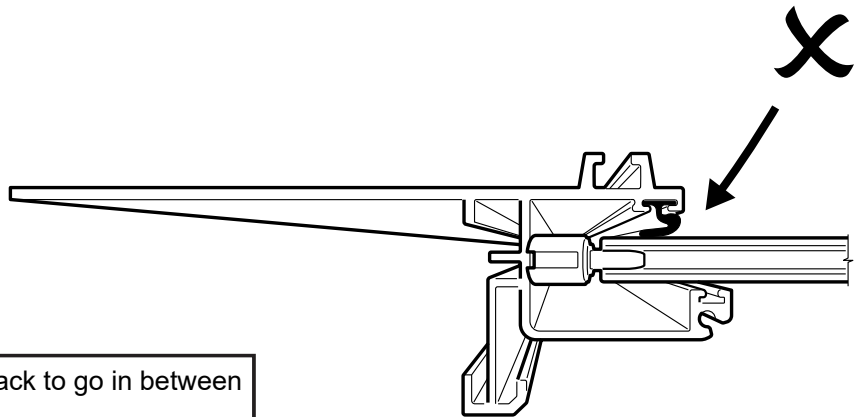
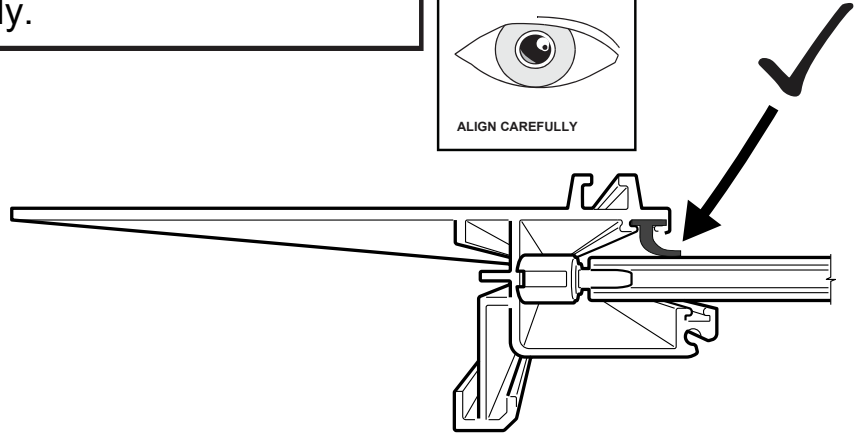
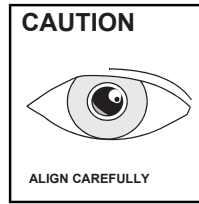

Align side rail to side of canister, guide the track to go in between the curtain end rubber stop.

NOTE: LHS side rail to be assembled first.

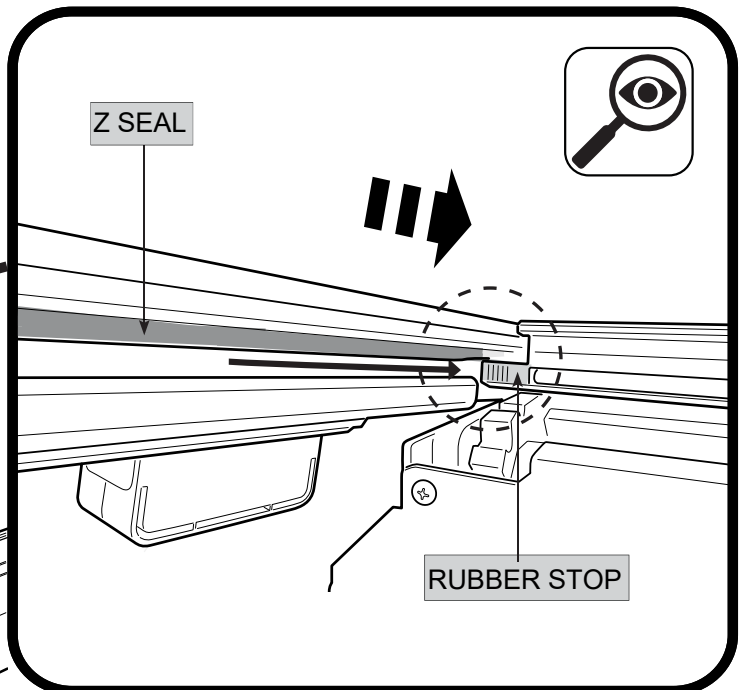
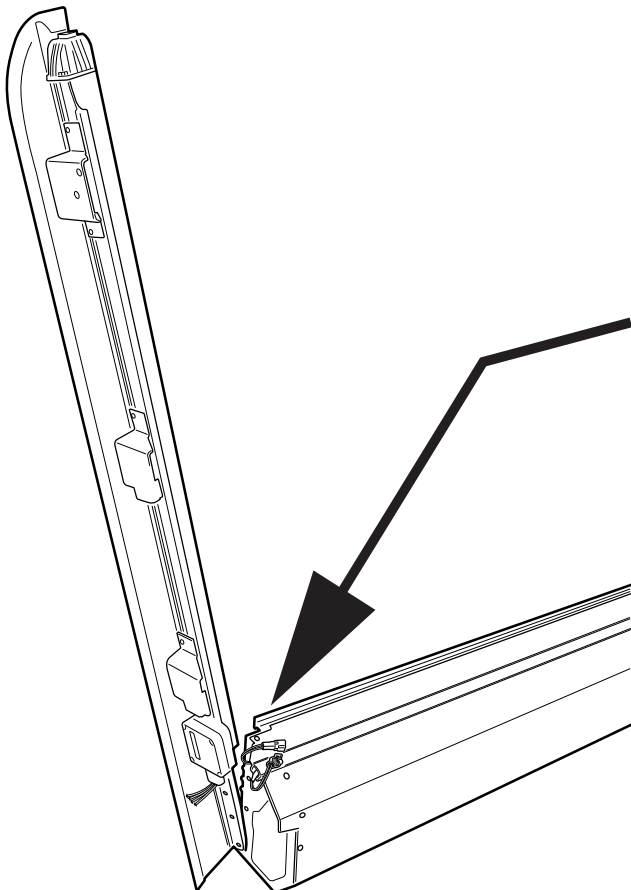

1. Using the retained screws, spring washer and washer, Loosely fasten the side rail to the location indicated.
2. Side rail edge must compress and meet with the canister profile as indicated below.
3. Fasten all screws tight.

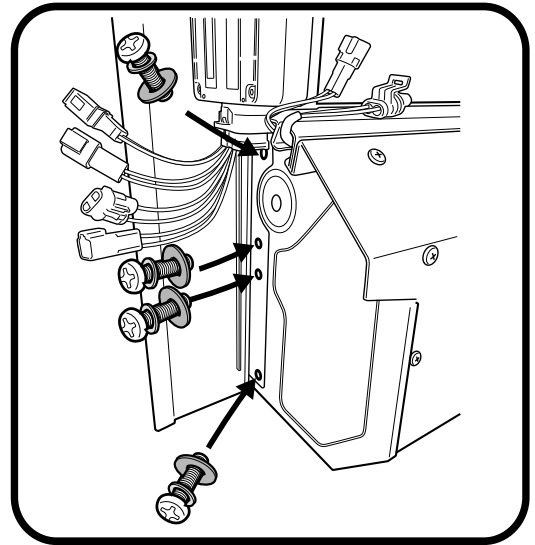
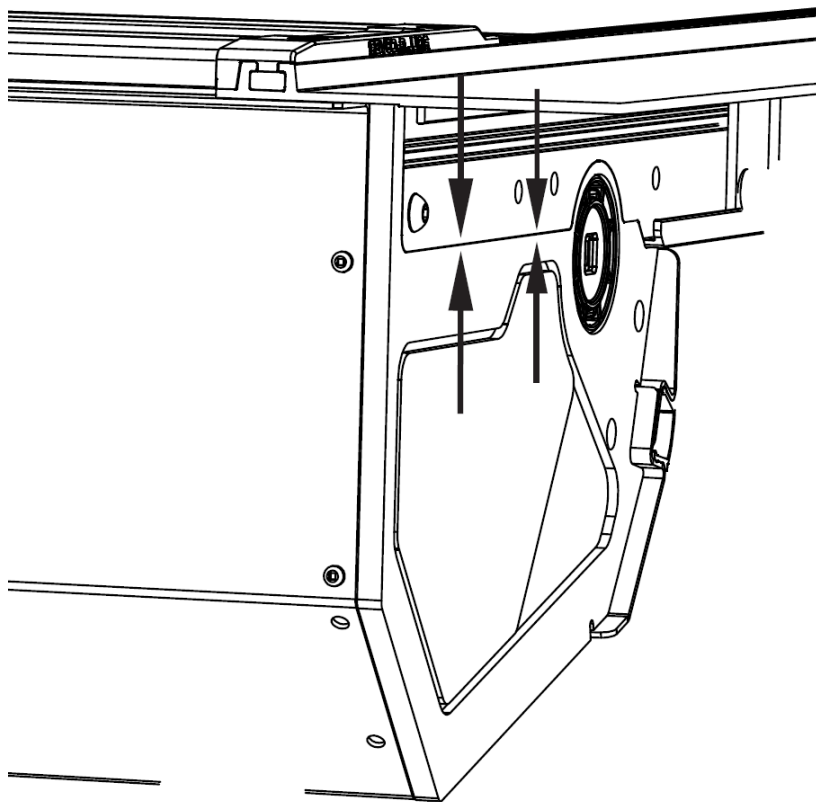
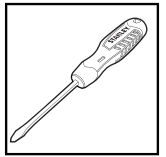

Connect motor connector to receiver

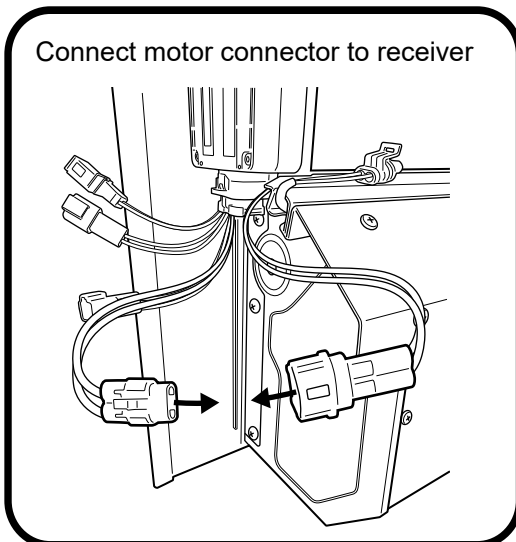

Connect LED Loom to receiver

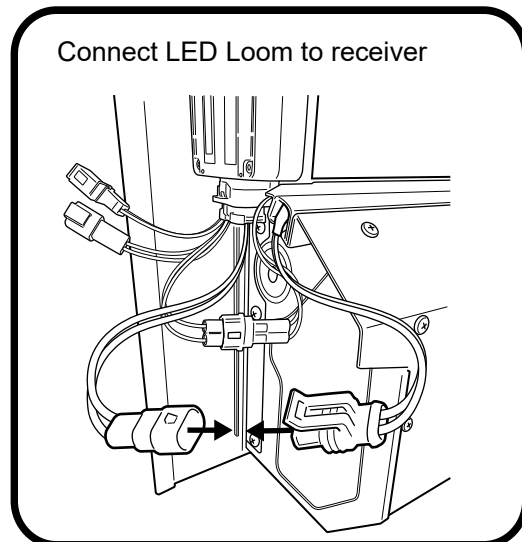



**Important Note:** Ensure that the Z seal within the track is positioned over the curtain and not folded inward. **WARRANTY** voided if assembled incorrectly.

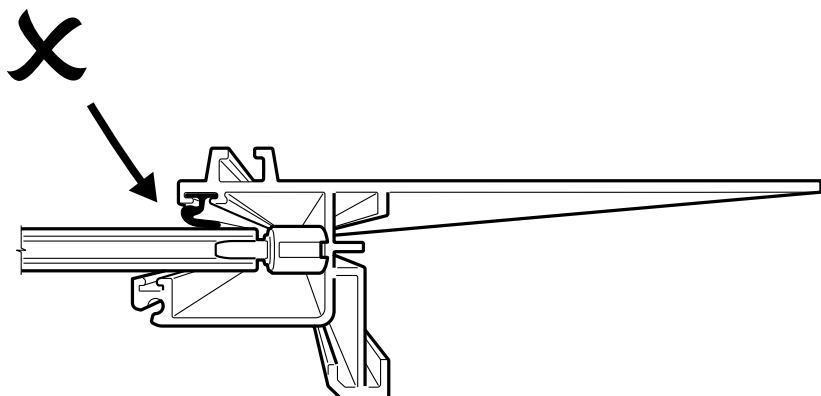
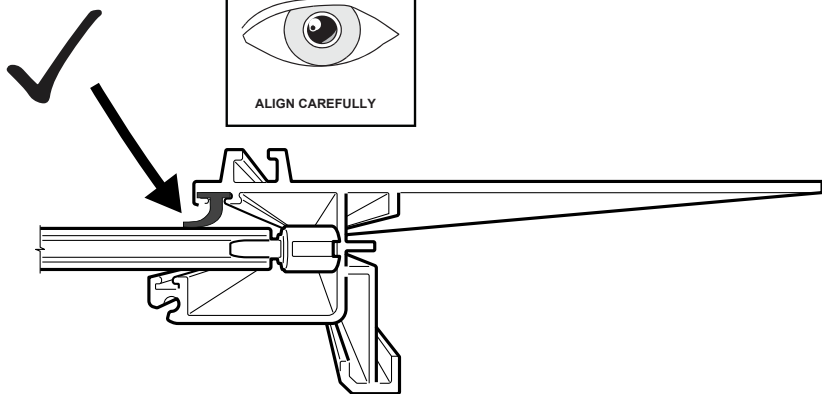
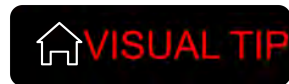

Align side rail to side of canister, guide the track to go in between the curtain end rubber stop.

NOTE: LHS side rail to be assembled first.

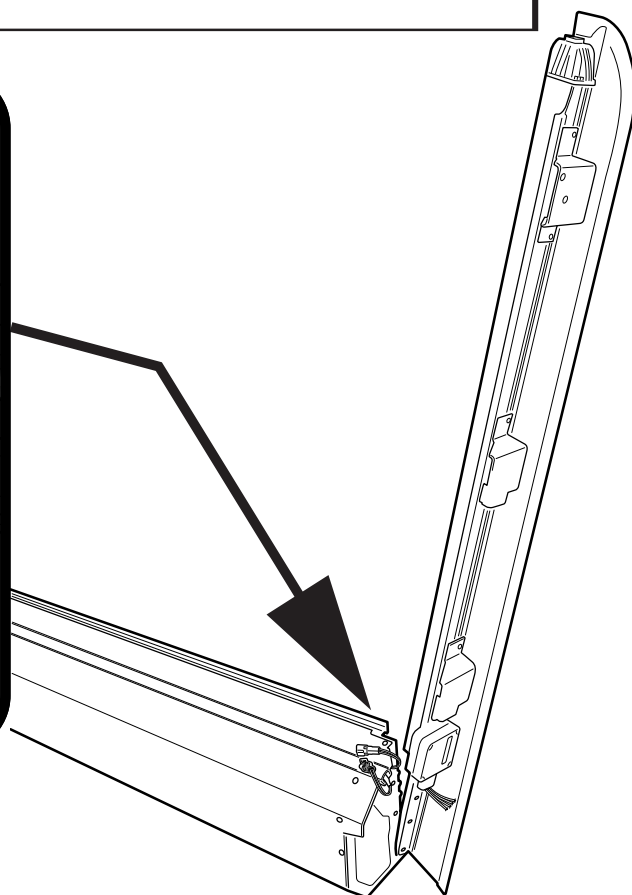
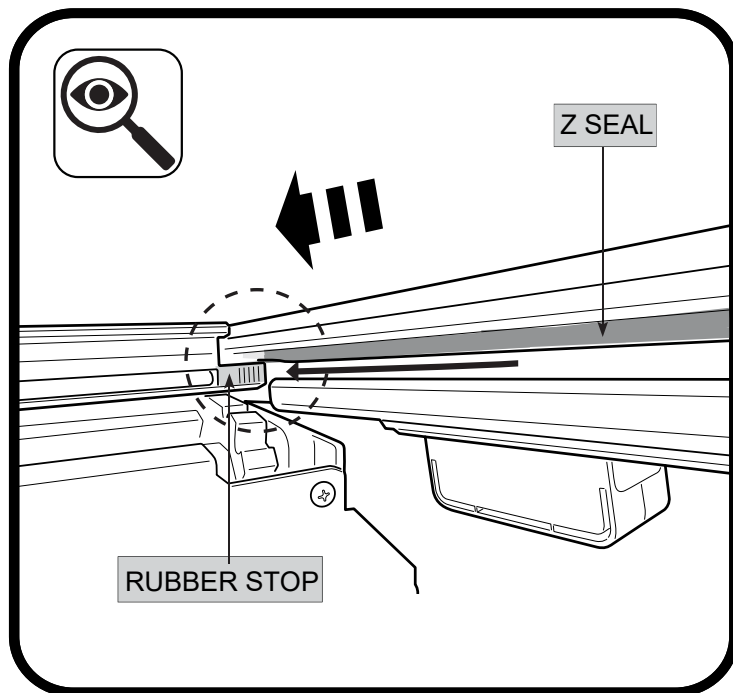

1. Using the retained screws, spring washer and washer, Loosely fasten the side rail to the location indicated.
2. Side rail edge must compress and meet with the canister profile as indicated below.
3. Fasten all screws tight.

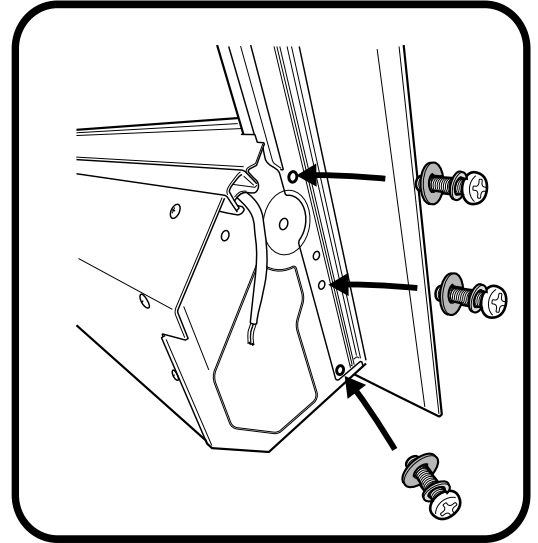
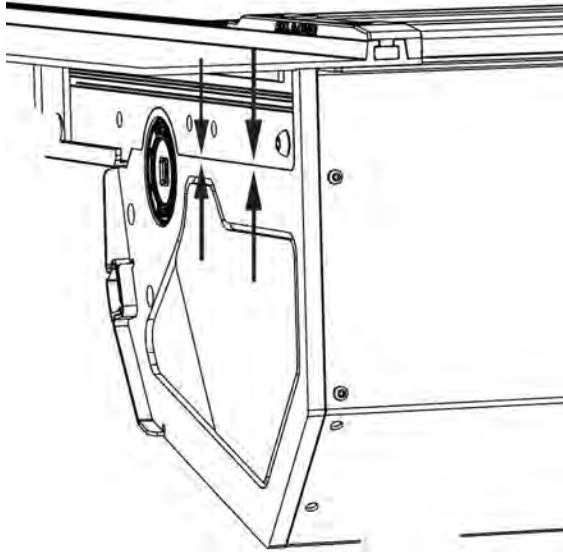
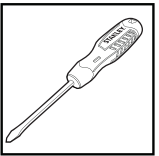

Feed M6 bolt through spring washer, motor and rubber bush.

**NOTE:** Rubber bush orientation has to be as per image. ( side with text on rubber, to face the motor).

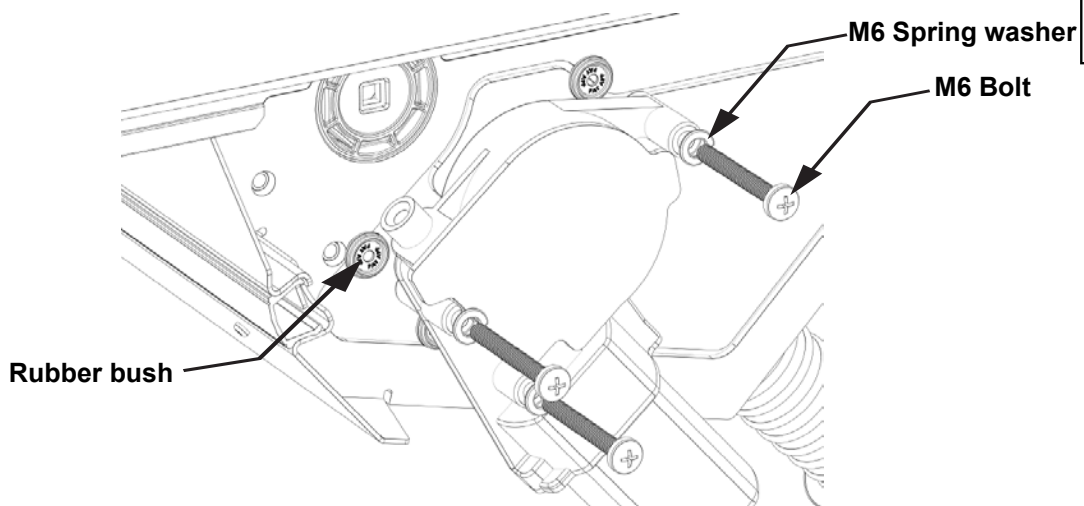
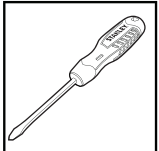

Align & insert motor shaft to axle.

**NOTE:** Pull / push curtain for axle to rotate.

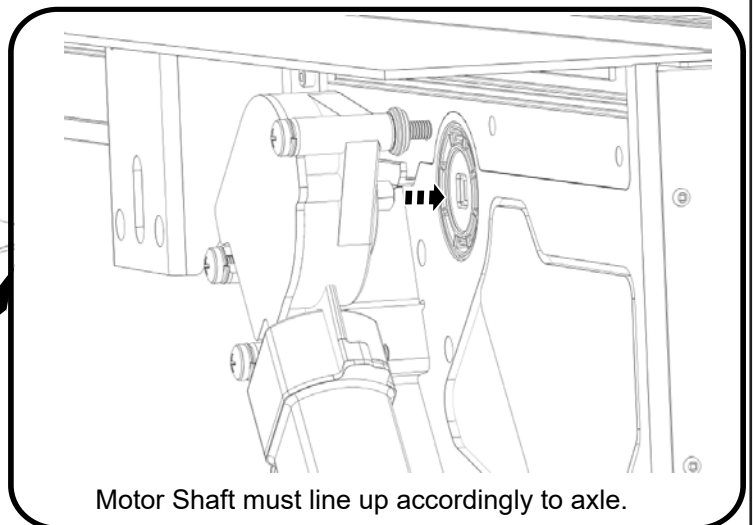
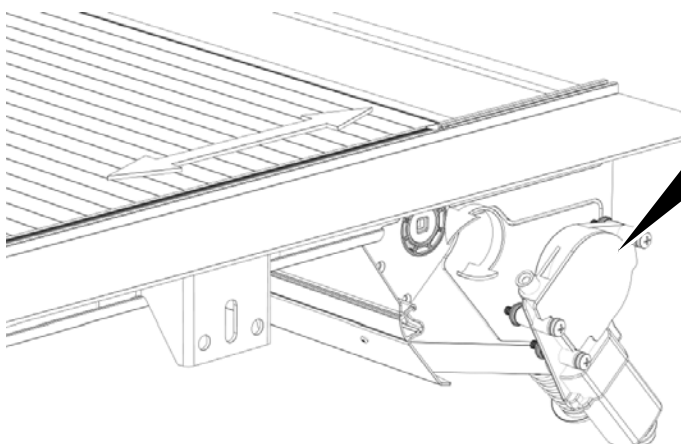

Motor Shaft must line up accordingly to axle.

Fasten all 3 screws to 2nm torque. Over tensioning will cause operating issue's.

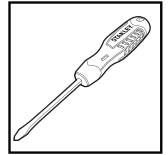
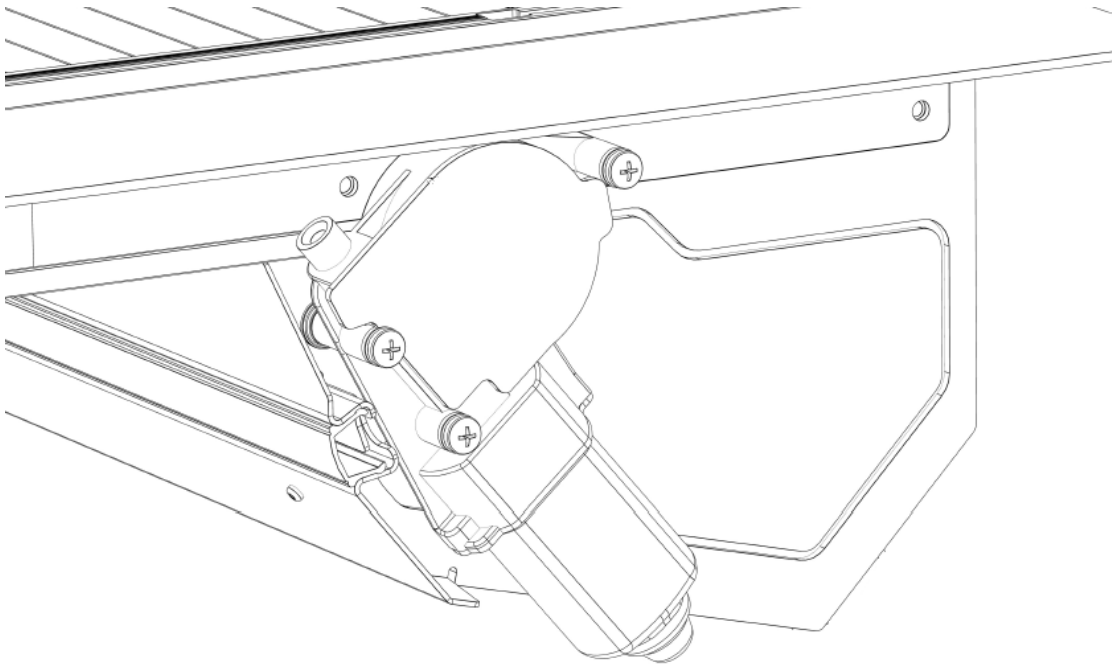

**Motor is to sit level.**

Any obstructions between motor and canister may cause operating issues.

Apply D-sponge foam tape to side rail as indicated. NOTE: Join foam firmly to the per-fitted foam of the canister. Carefully trim excess off & discard as indicated. Repeat on the other side.

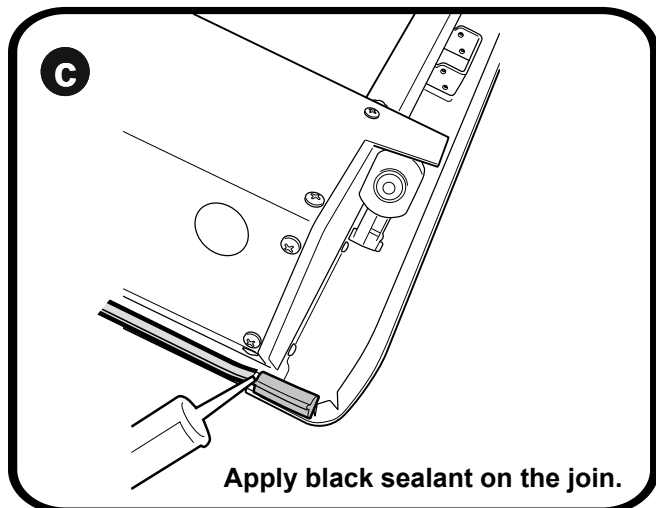
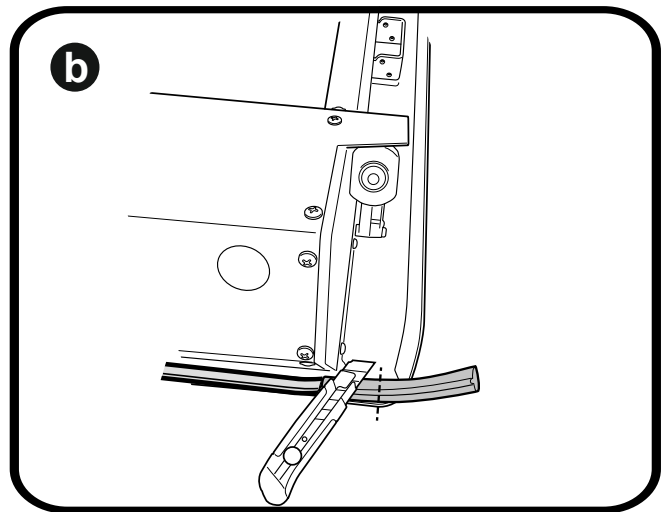
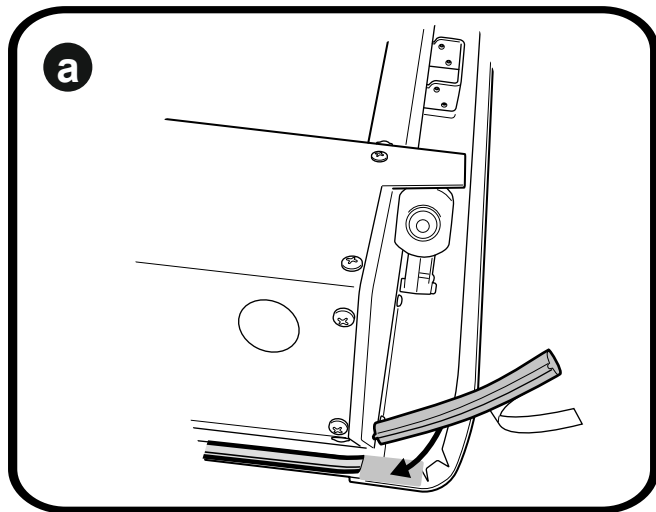

Apply black sealant on the join.

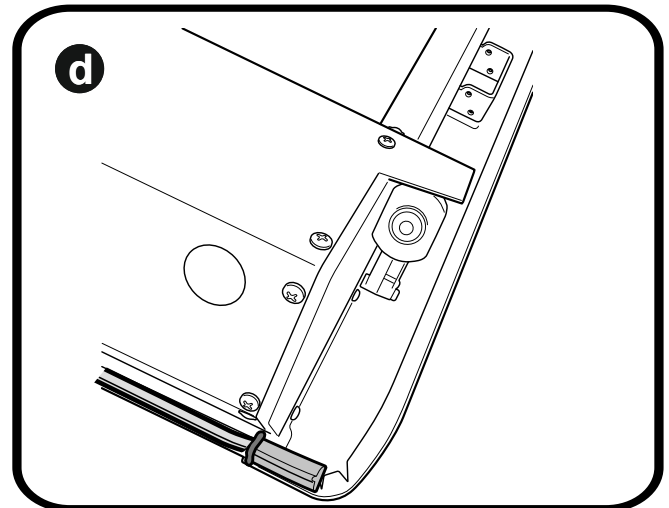

Carefully bring down the assembled unit.

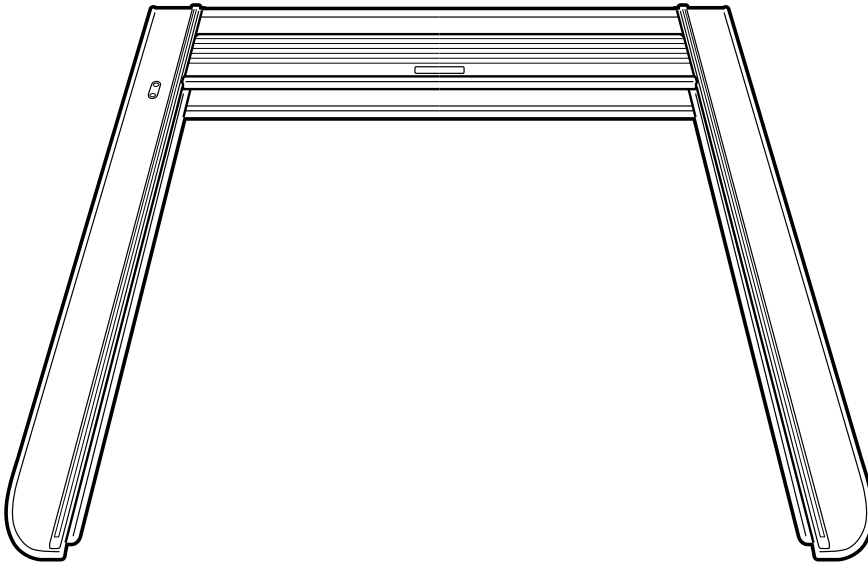

Insert side end caps to the top cover.

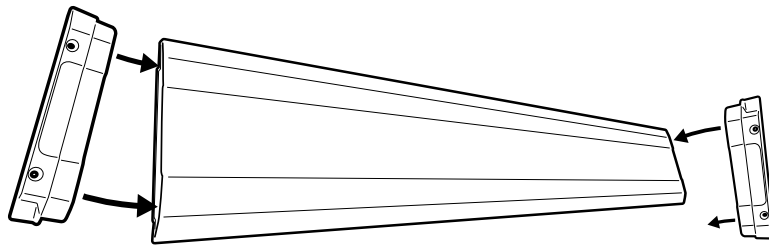

Place & Align top cover over the canister and side rails.

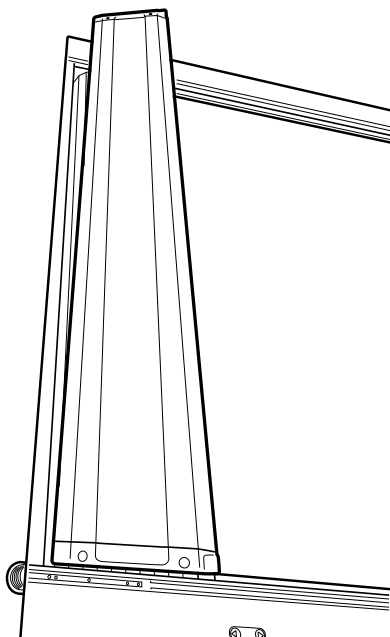

Using countersunk screws provided, line up end cap holes to the threads on the side rail. Fasten to 3nm torque. Repeat to the other side.

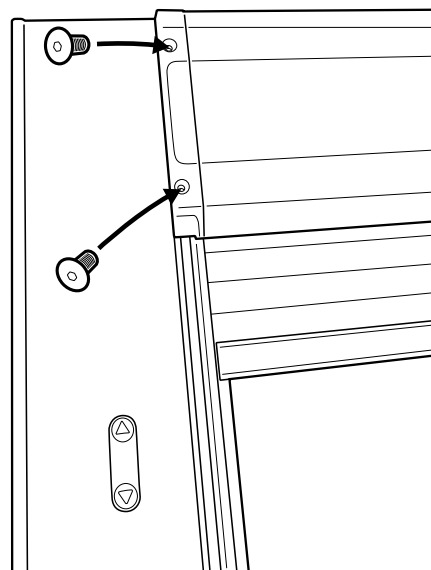

Seal any exposed gaps or holes on the front panel of the Ute bed with sealant.

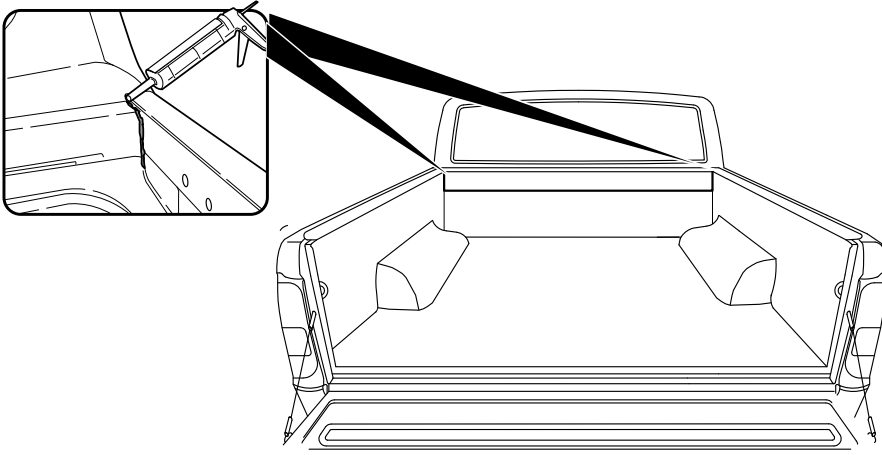

Seal any joins of the front tub inner panels which have gaps with sealant.

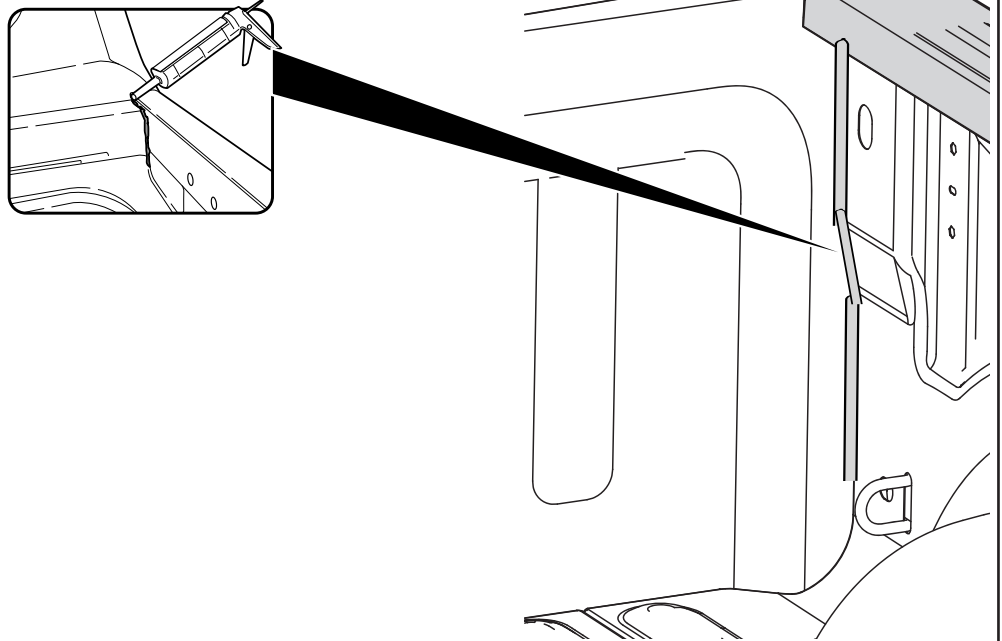

Place the Roll-R-Cover unit on to Ute bed.

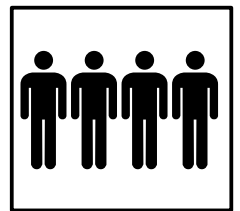
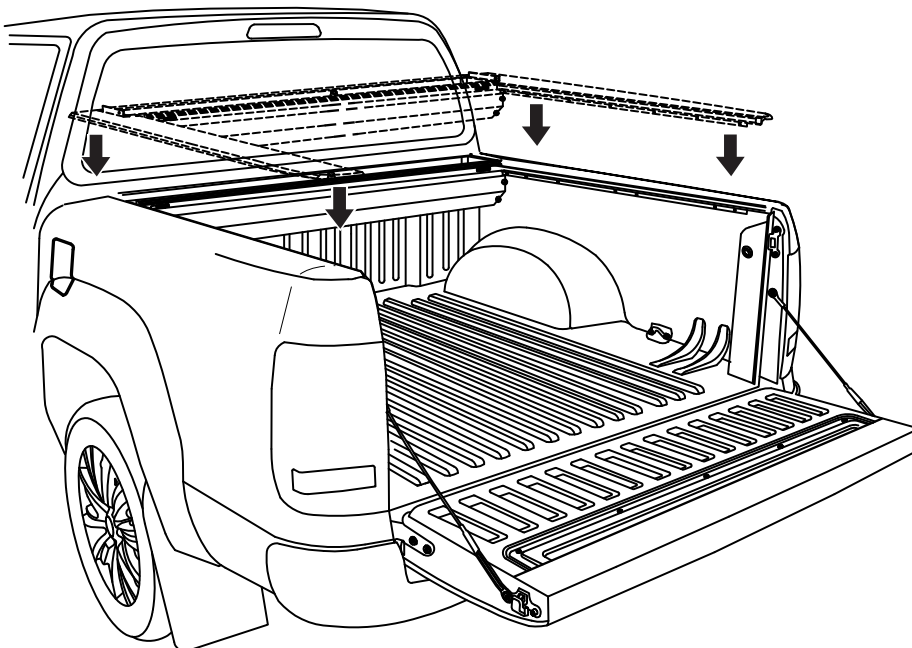

4 People  
Recommended for lift



With care, pull out any side rubber that has folded under the side rail.

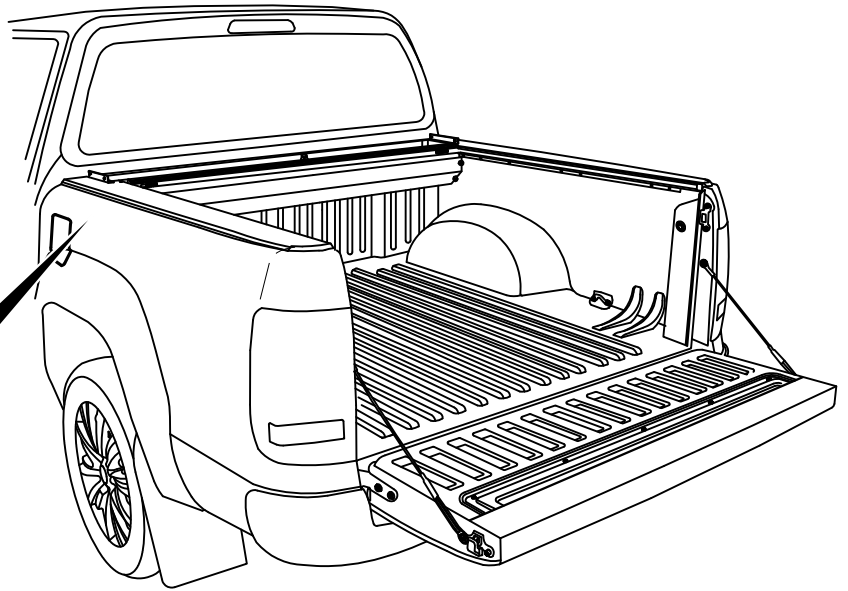
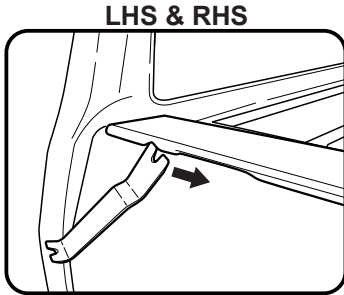

With the tailgate up (Closed position),  
Pull left & right hand side rails  
towards the tailgate, stopping short by  
5mm between tailgate and side-rail  
endcap.

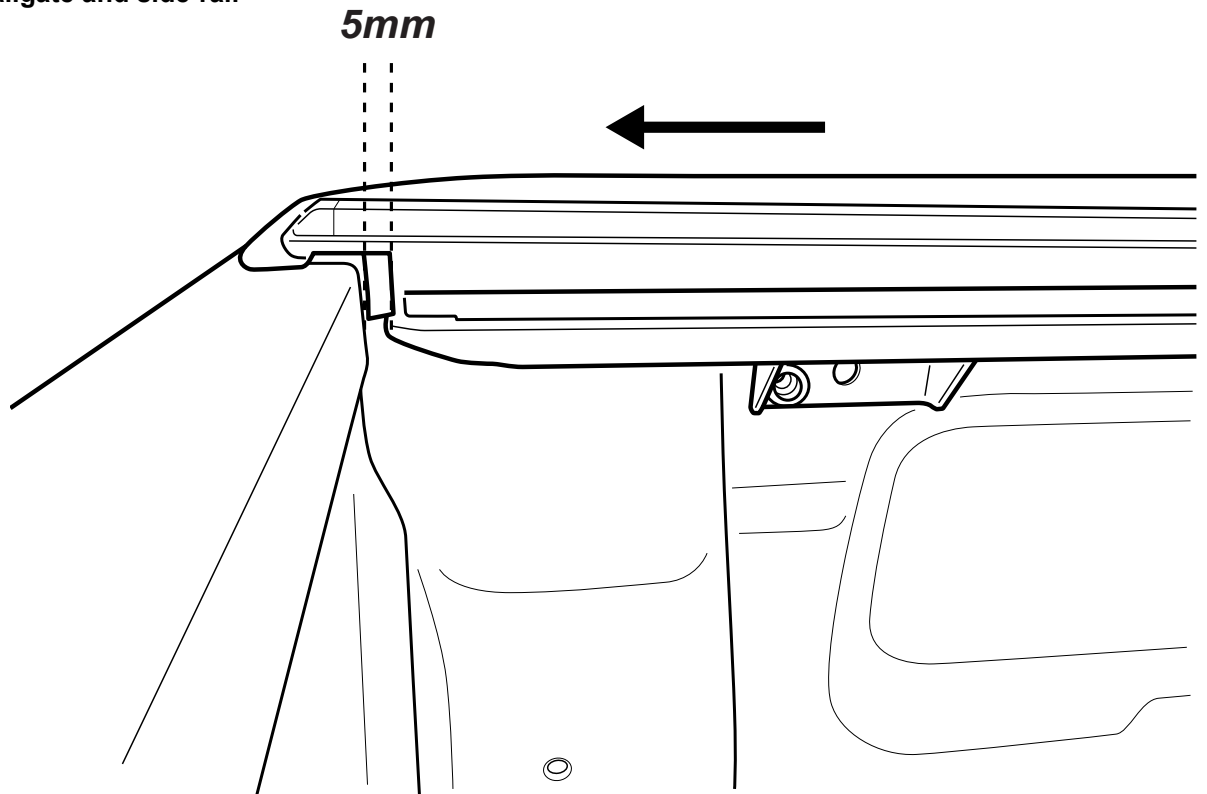

Foam compressed to  
5mm when tailgate is  
closed.

Gap between tailgate and side-rail end cap to be 5mm.



Foam compressed to 5mm when tailgate is closed.

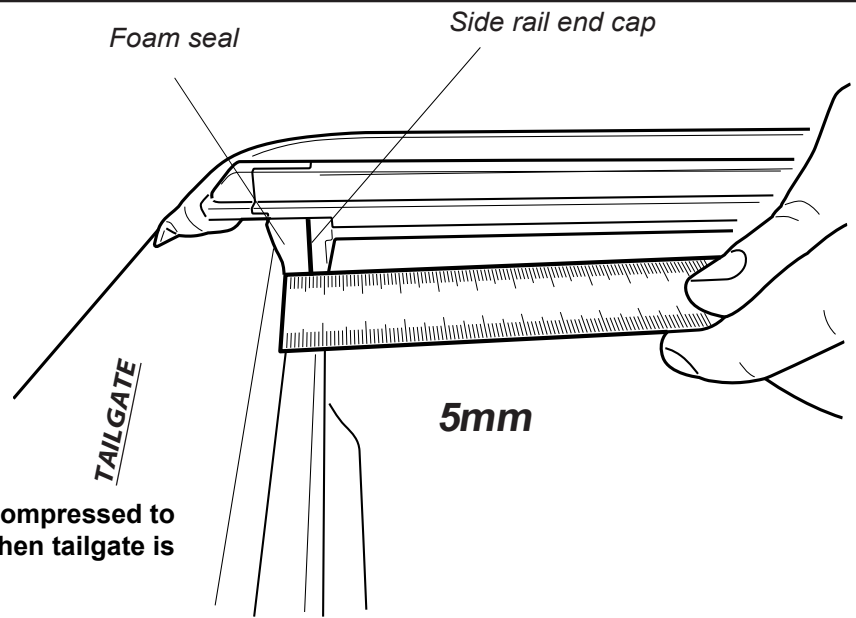

Position clamp behind the inner top lip of the bed rail and the **center elongated** hole of the side rail mounting brackets. Repeat to all 6 positions.

Ensure the M8 nut is in the indicated slot of the clamp

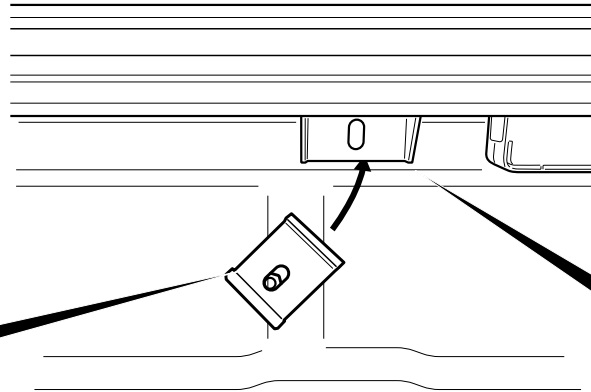
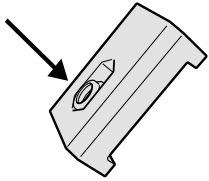

Fasten clamp loosely into position using M8 washer, M8 spring washer and M8 x 35mm bolt.

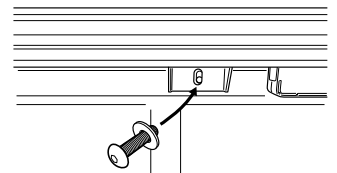

1. Apply downward pressure on side rails.
2. Lift **clamp** all the way up or as far up as possible then fasten clamp to 14Nm torque in the order indicated below.

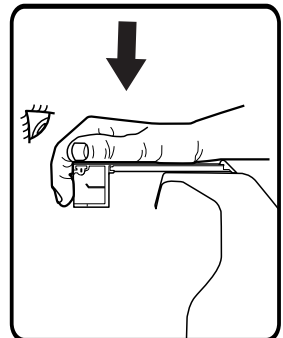
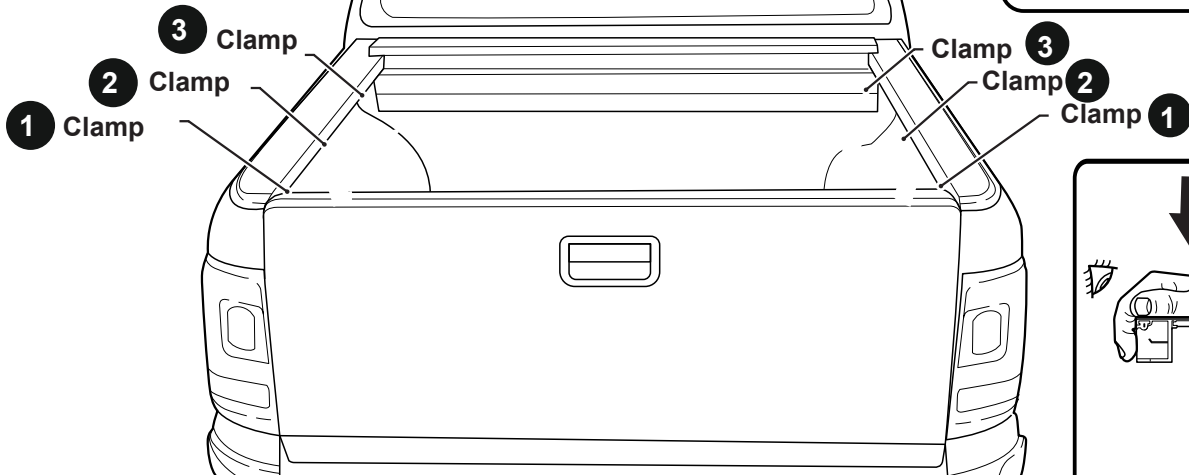
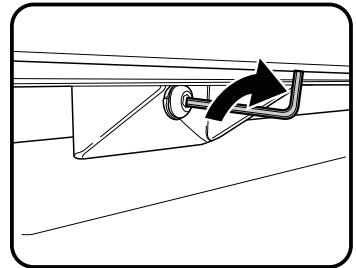

Apply flat plate behind adjusting bolt hole to the ute bed panel or to the liner if the Ute is equipped with a tub liner.

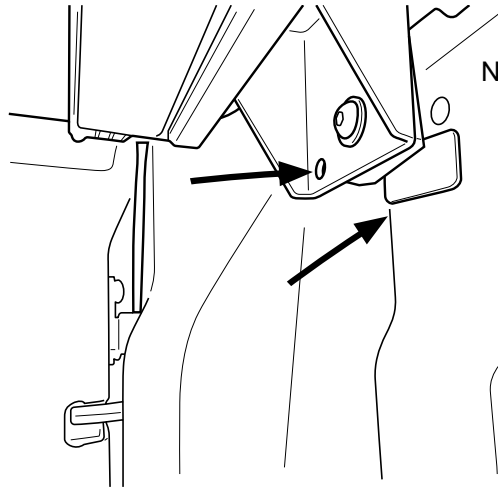

Note: Rear Clamp bracket.



Note: Clean surface before applying flat plate.

Feed M8 nut into M8x90mm bolt and through clamp bracket's pre-installed nutsurt as indicated.

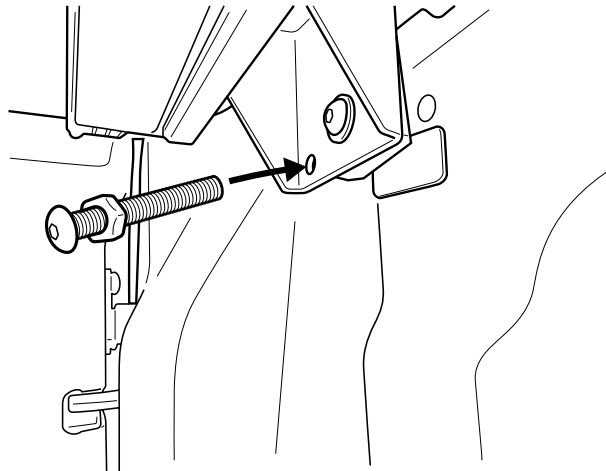

Side rail rubber to sit 1mm below from the top of the tailgate in the closed position.

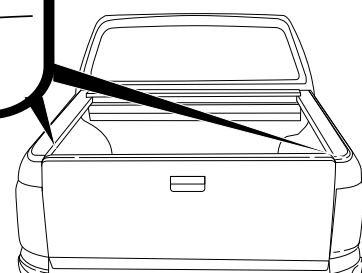
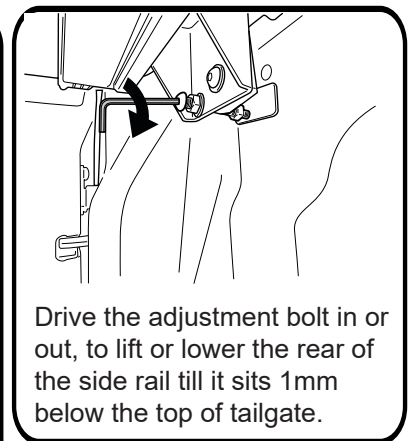
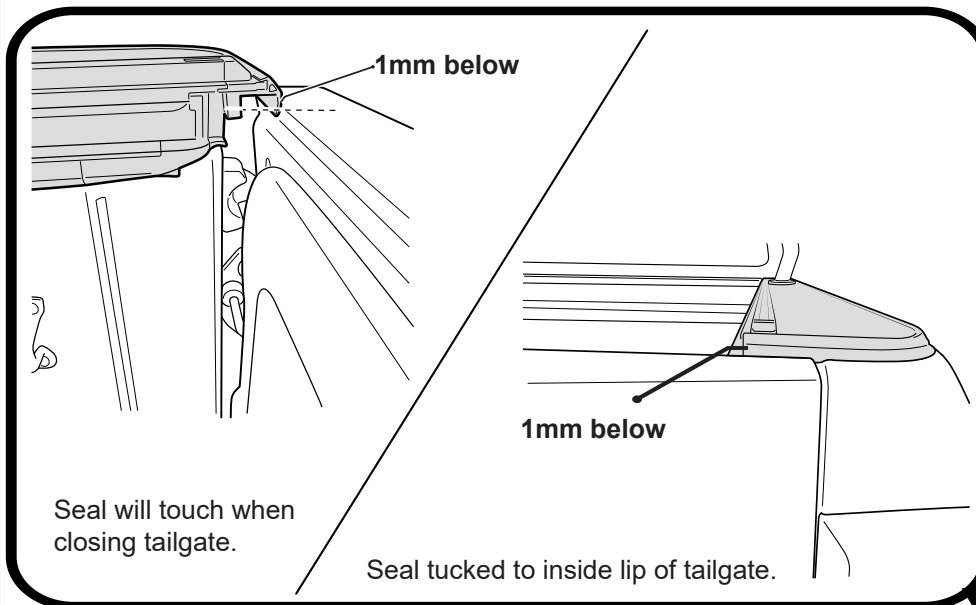

Fasten the M8 nut against clamp bracket.

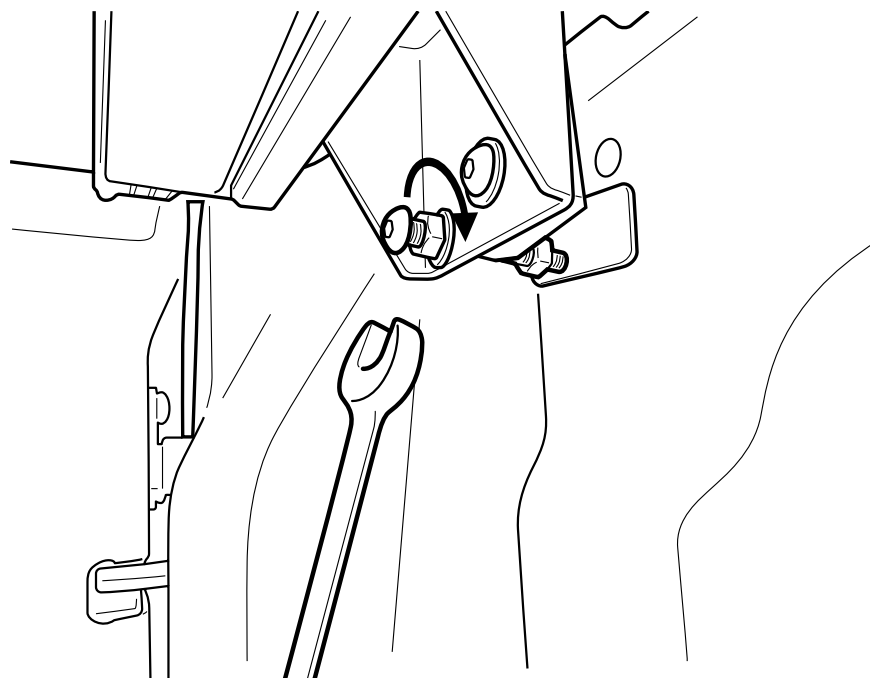

**Install front drain pipes through pre-drilled holes of the canister. ( RHS/LHS)**



Note: With care push tube in. Gently pull the tube back so it seals correctly against the front panel of the tub.



 **VISUAL TIP**

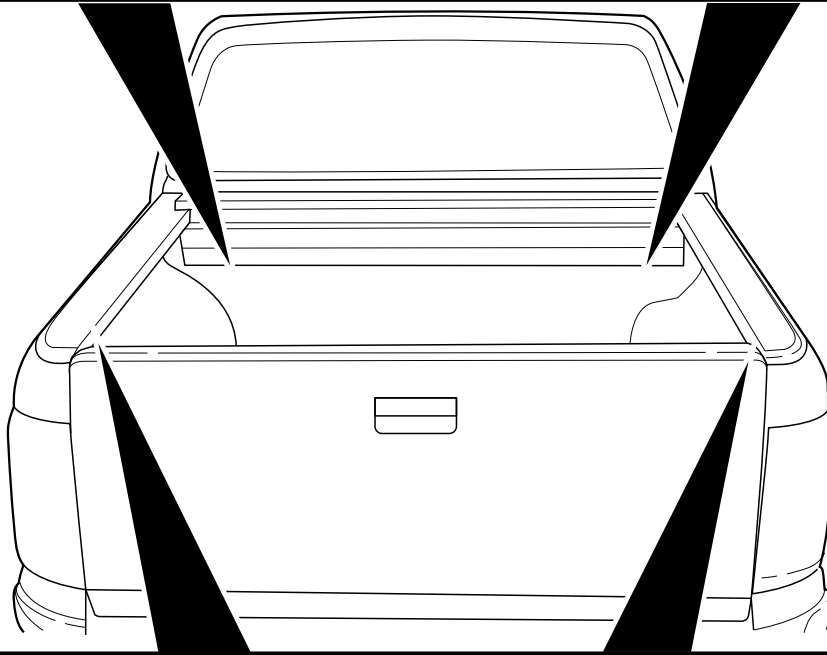
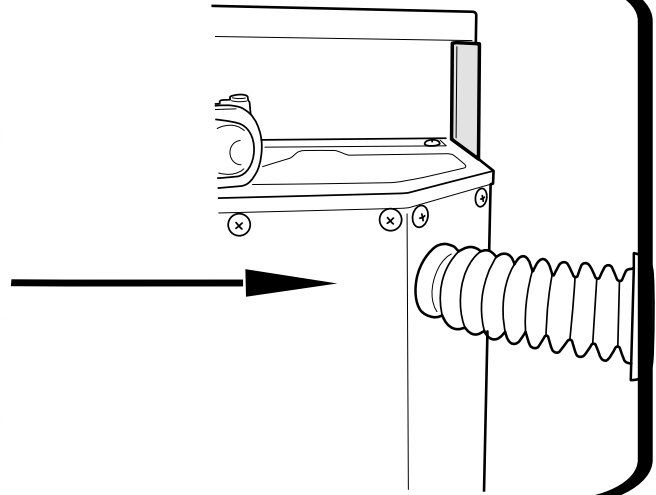
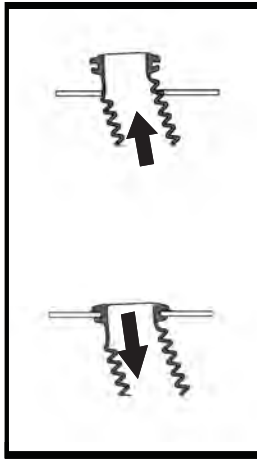

Note: With care push rear pipe in. Gently pull the pipe back so it seals correctly within the side rail channel.

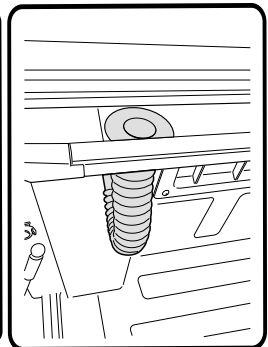
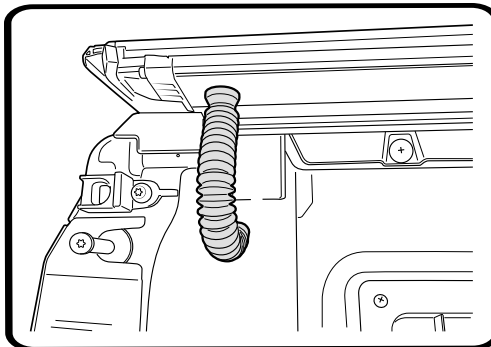
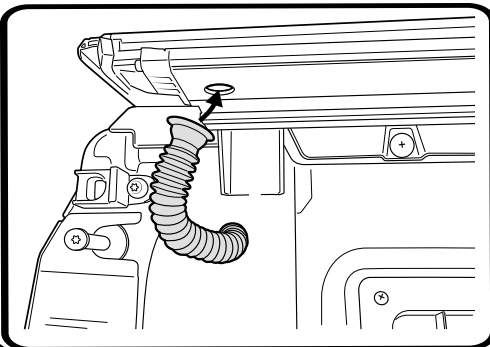
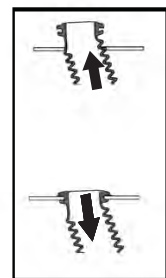

**Install rear drain pipes through pre-drilled holes of the siderails. ( RHS/LHS)**

- a. Connect Battery loom S2.75 to Receiver loom.
- b. **Carefully** connect CI-Loom-short to Receiver loom.



Align connectors carefully to avoid pushing pins out.

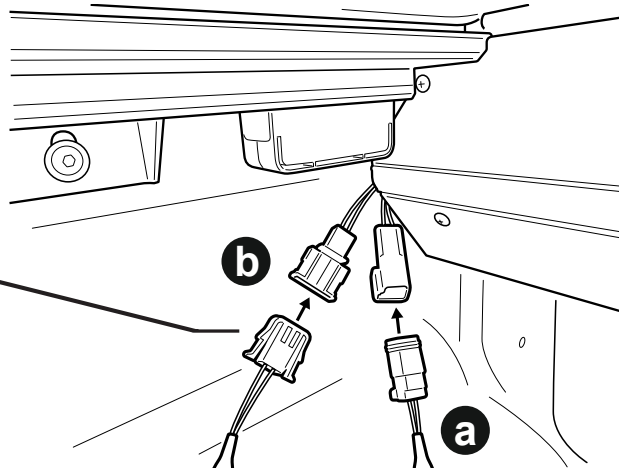

NOTE: 1. To wear in the Roll R Cover please fully open & close the cover approximately 15 times after install is complete.

2. Set your vehicle locking system to unlock all doors with one press of the factory remote unlock button. This setting can be found in your vehicle settings.

### Operating instructions:

Press unlock on vehicle key fob to activate controller.

When vehicle is unlocked the side rail sensor buttons will be active to control.

When vehicle is locked the side rail sensor buttons will be inactive.

### Using factory key fob to operate:

Pressing unlock twice on the factory key fob within 4 seconds, will activate the roll r cover to open.

Pressing lock twice on the factory key fob within 4 seconds, will activate the roll r cover to close.



### Vehicle proximity:

Tapping the proximity twice to open or lock the car door will act exactly the same way as the key fob being pressed twice.

Touch & let go to open, touch & let go again to pause.

Touch & let go to close, touch & let go again to pause.

