

ARMOUR BAR FITTING INSTRUCTIONS TO SUIT New-Gen Mitsubishi MV Triton

Check contents of kit before commencing fitment and report any discrepancies

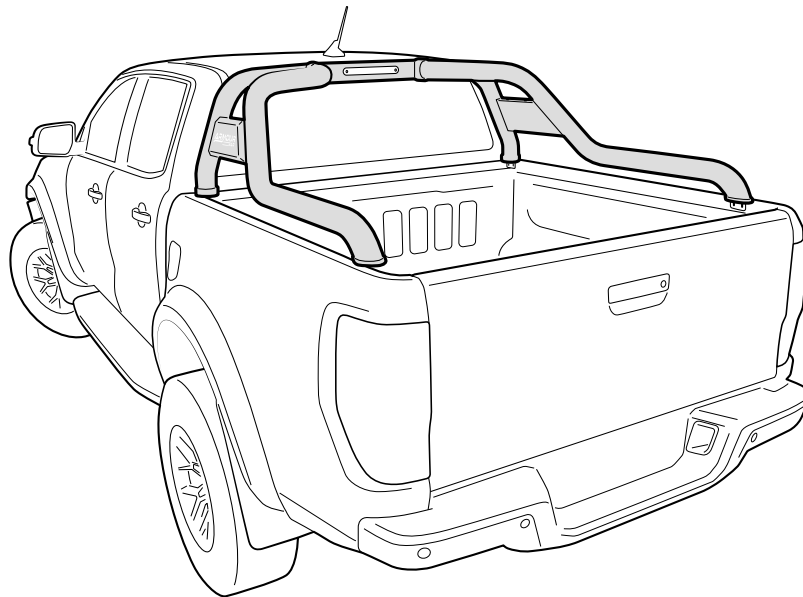

*Image example shown only

| | | | | |
|--|---|--|--|--|
| IMPORTANT | <ul style="list-style-type: none"> • Do not stand/sit or rest heavy objects on Armour bar. • Do not strap objects to the Armour bar. | | | |
| Care Instructions | <ul style="list-style-type: none"> • Read Instructions fully before commencing installation. • Clean Armour bar with a mild detergent and water solution • Do not use abrasive cleaners or solvents • Refer to manufactures instructions applicable to power drill. • Protect Tub & tub floor against scratches during installation process. | | | |
| Maintenance | <p>Check all fasteners regularly to make sure they are torqued up.</p> | | | |
| Tools Required | <table style="width: 100%; border: none;"> <tr> <td style="vertical-align: top;"> <ul style="list-style-type: none"> • Pen / Marker • Centre Punch • Drill & Drill bits </td> <td style="vertical-align: top;"> <ul style="list-style-type: none"> • Masking Tape • Spanner & Socket • Tape measure </td> <td style="vertical-align: top;"> <ul style="list-style-type: none"> • Soapy water solution • Allen Key set (Metric) • Test light </td> </tr> </table> | <ul style="list-style-type: none"> • Pen / Marker • Centre Punch • Drill & Drill bits | <ul style="list-style-type: none"> • Masking Tape • Spanner & Socket • Tape measure | <ul style="list-style-type: none"> • Soapy water solution • Allen Key set (Metric) • Test light |
| <ul style="list-style-type: none"> • Pen / Marker • Centre Punch • Drill & Drill bits | <ul style="list-style-type: none"> • Masking Tape • Spanner & Socket • Tape measure | <ul style="list-style-type: none"> • Soapy water solution • Allen Key set (Metric) • Test light | | |

PARTS CHECK SHEET

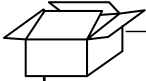

PARTS IN MAIN CARTON

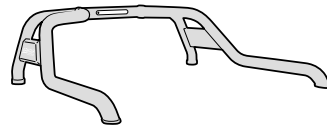



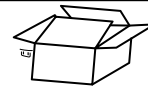



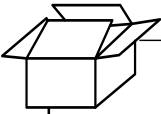









Armour Bar



Fitting Kit
Qty - 1





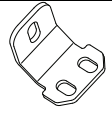

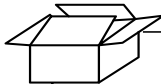











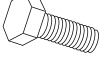

PARTS IN FITTING KIT

| | | | | | | | |
|--|--|---|--|---|--|--|--|
| 20042403801  FRONT TUBE ASSEMBLY Qty - 1 | 20040938201  SIDE TUBE(L) Qty - 1 | 20040943201  SIDE TUBE(R) Qty - 1 | 20040942601  SIDE PLATE ASSEMBLY(L) Qty - 1 | 20042173401  BACK COVER FOR SIDE PLATE(L) Qty - 1 | 20040944101  SIDE PLATE ASSEMBLY(R) Qty - 1 | 20042173501  BACK COVER FOR SIDE PLATE(R) Qty - 1 | |
| 20042554001  FRONT MOUNT BRACKET(L) Qty - 1 | 20042554101  FRONT MOUNT BRACKET(R) Qty - 1 | 20008912301  JOINT RUBBERCOVER(L) Qty - 1 | 20009589301  JOINT RUBBERCOVER(R) Qty - 1 | 20008160801  HOLE PLUG Qty - 2 | 20007045301  FRONT RUBBER FOOTING Qty - 2 | 20042379701  REAR RUBBER FOOTING Qty - 2 | |
| 20042554201  REAR MOUNT BRACKET(L) Qty - 1 | 20042554301  REAR MOUNT BRACKET(R) Qty - 1 | AB-T-FRONT  FRONT MOUNT BRACKET MV TRITON Qty - 2 | | | | | |

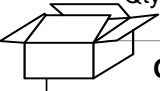

LID NUTS AND BOLTS

| | | | | | | |
|--|--|---|---|---|--|--|
| 3005581  M10 x 60 ALLEN Head Bolt Qty - 2 | E3000145  M8 SPRING WASHER Qty - 8 | E3000233  M6 LARGE WASHER Qty - 14 | E3008096  M8 FLAT WASHER Qty - 8 | E3000325  M10 FLAT WASHER Qty - 2 | E3008183  M8 FLANGE NUT Qty - 8 | |
| E3008066  M6 FLANGE NUT Qty - 8 | E3008107  M10 SPRING WASHER Qty - 2 | E3008109  M6 HEX BOLT Qty - 8 | E3008155  M8 HEX BOLT Qty - 8 | E3008097  M8 HEX FLANGE BOLT Qty - 8 | E3005469  M6 x 20 ALLEN Head Bolt Qty - 6 | |
| E3008196  M6 SPRING WASHER Qty - 6 | E3008270  M8 x 40 ALLEN Head Bolt Qty - 4 | OTHER  | | 3000062  S4 ALLEN KEY Qty - 1 | 3000078  S6 ALLEN KEY Qty - 1 |  Fitting Instructions Qty - 1 |

Thoroughly clean installation areas.

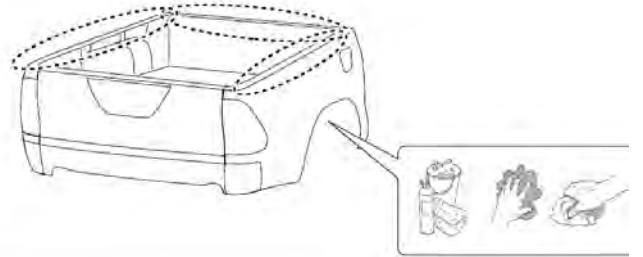

Place part number 20009589301 (JOINT RUBBERCOVER(R)) to 20042403801 (FRONT TUBE ASSEMBLY),
Repeat to the other side using part number 20008912301

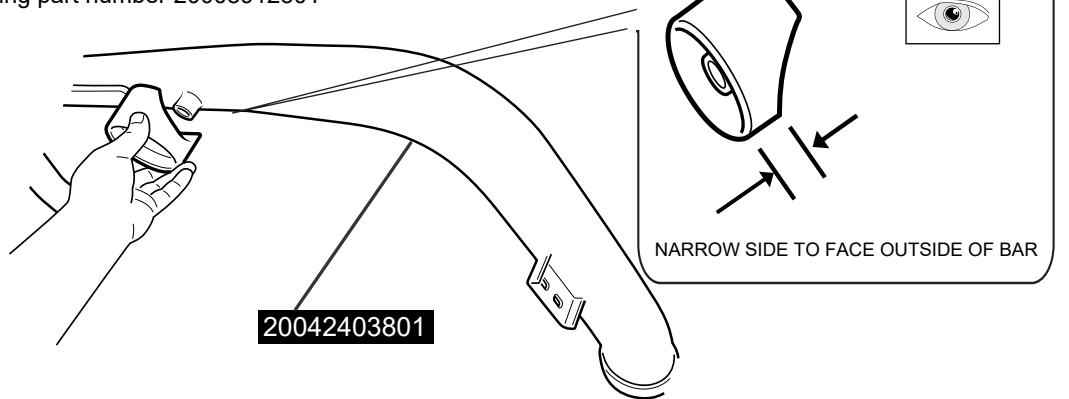

Feed into place part number 20040943201 (SIDE TUBE(R)) through 20009589301 and 20042403801.
Repeat to the other side using part number 20040938201 (SIDE TUBE(L))

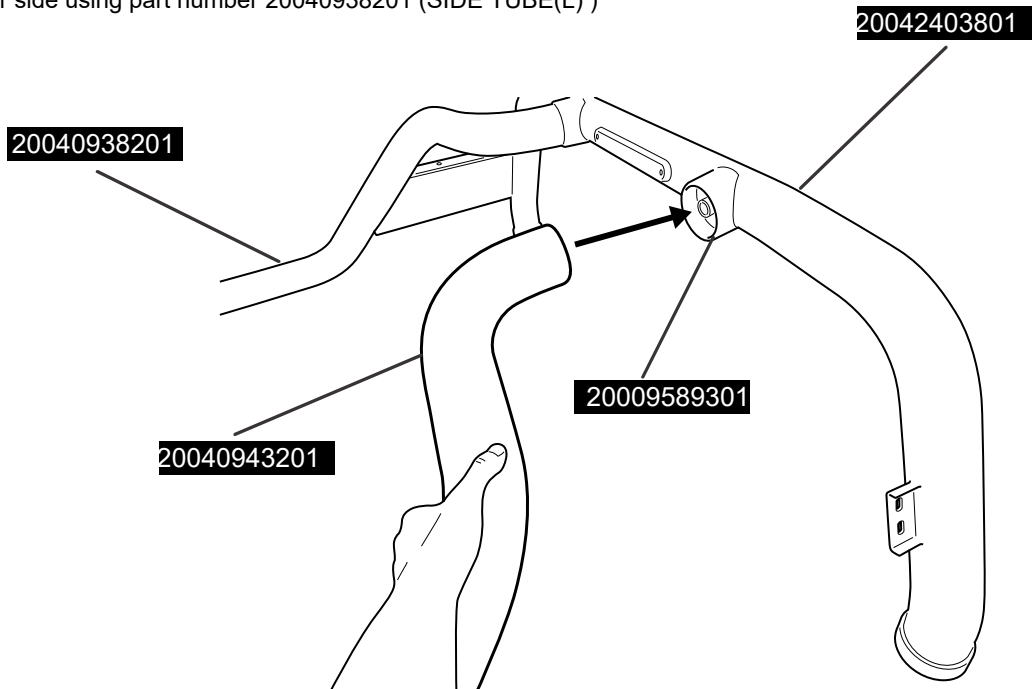

Feed part number 3005581 (M10 Allen head bolt) through E3008107 (M10 spring washer) , E3000325 (M10 washer), 20042403801 (Front tube assembly) and fasten to 20040943201 (SIDE TUBE(R)). Repeat to the other side.

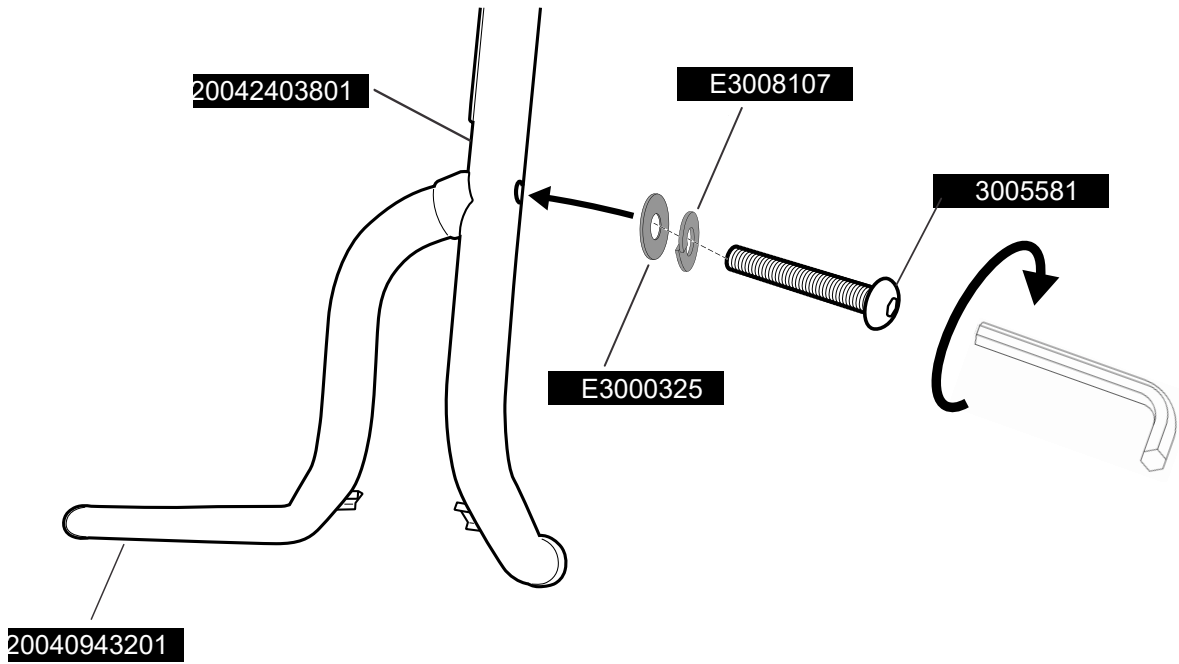

Align part number 20040944101 (side plate assembly (R)) as indicated.

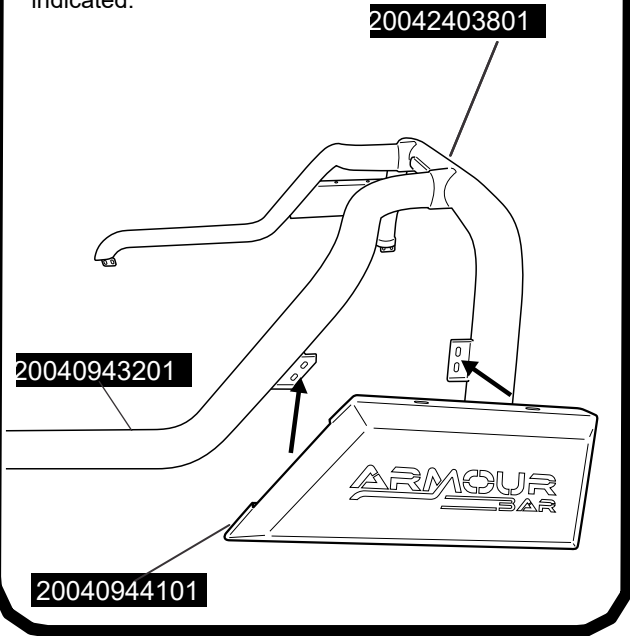

Fasten into position using, M6 Hex Flange bolt trough M6 large washer, the tube tabs, side plate tabs, & M6 Flange nut. Repeat to all 4 points.

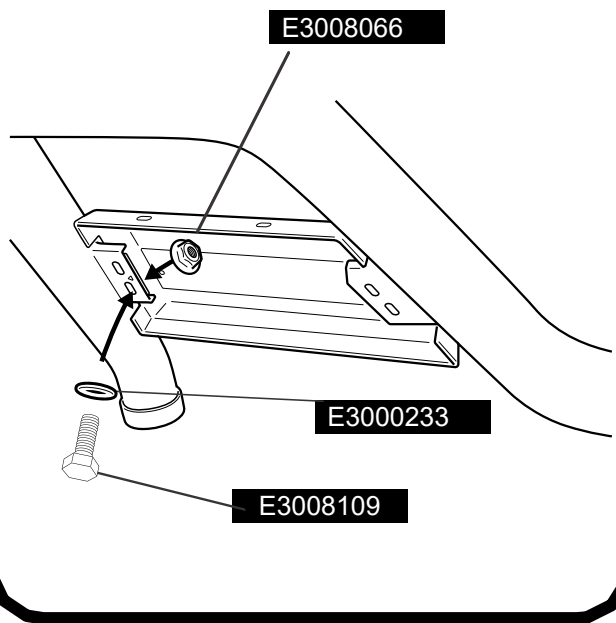

Repeat above steps to the other side using part number 20040942601 (side plate assembly (L))

Align part number 20042173501 (back cover for side plate (R)) as indicated.

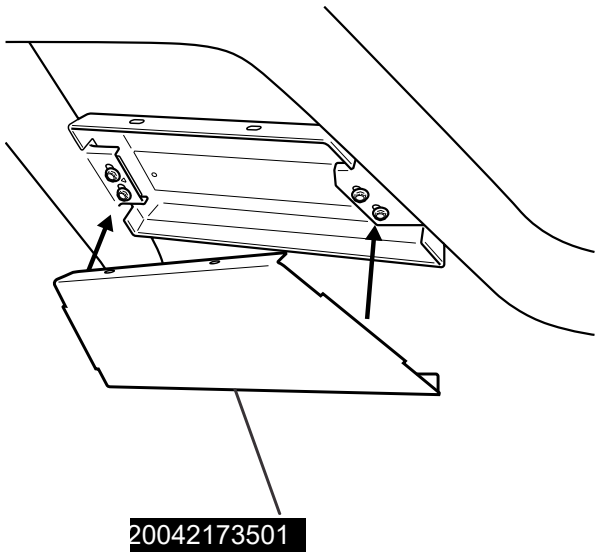

Fasten into position using M6x20 Allen head bolt through M6 spring washer and M6 large washer.

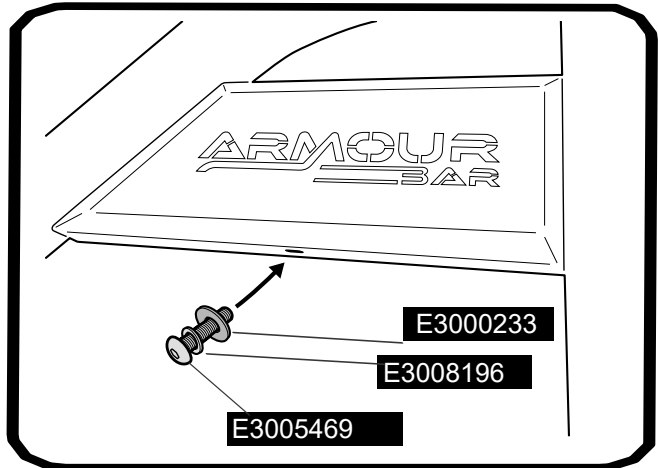
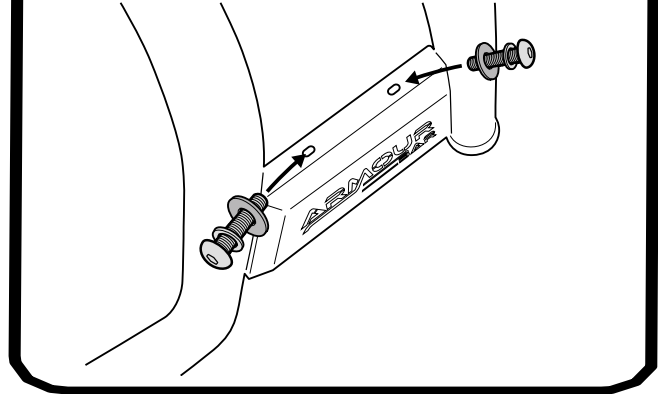

Repeat above steps to the other side using part number 20042173401 (back cover for side plate L))

Push in to position part number 20008160801 (hole plug) as indicated.
Repeat to the other side.

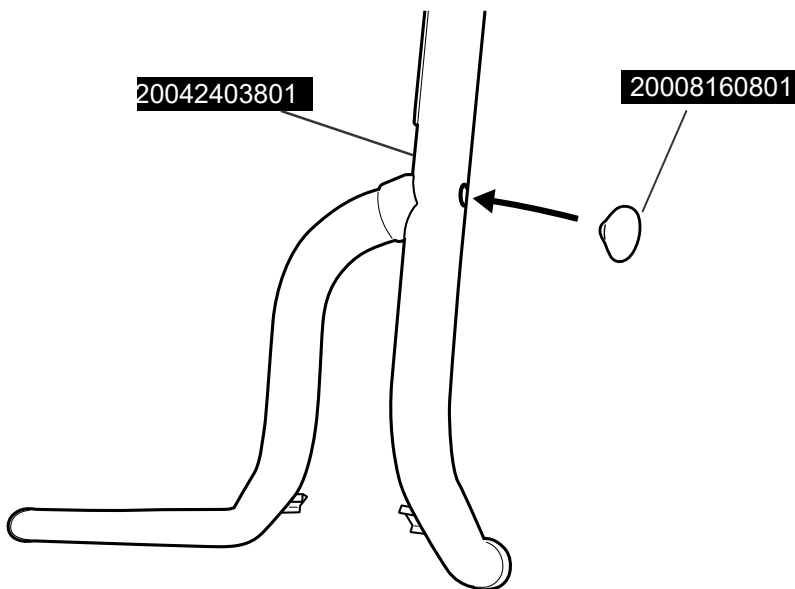

Using part number 20007045301 slide over front tube of Armour bar.

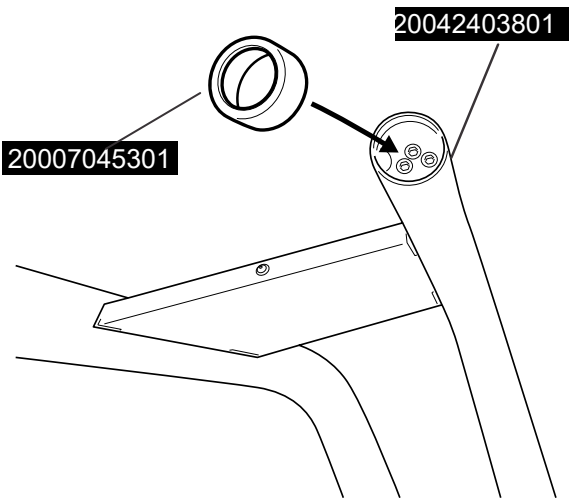

Using part number 20042379701 slide over rear tube of Armour bar.

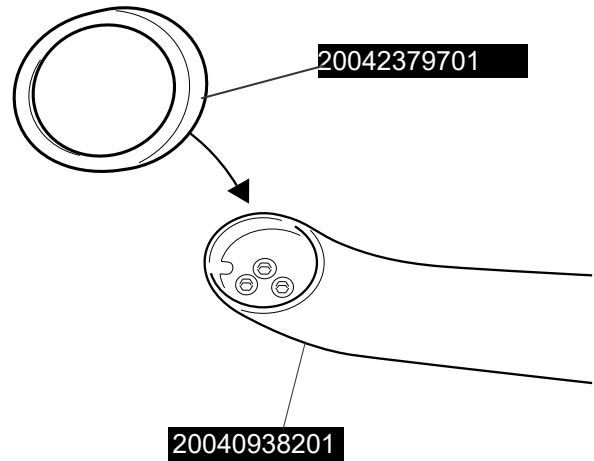

Repeat above steps to the other side using part number 20007045301 & 20042379701

1. Align part number AB-T-FRONT (front mount bracket as in the specified orientation.
2. Fasten in to position using M8 x 25mm hex bolt, M8 spring washer and M8 flat washer.

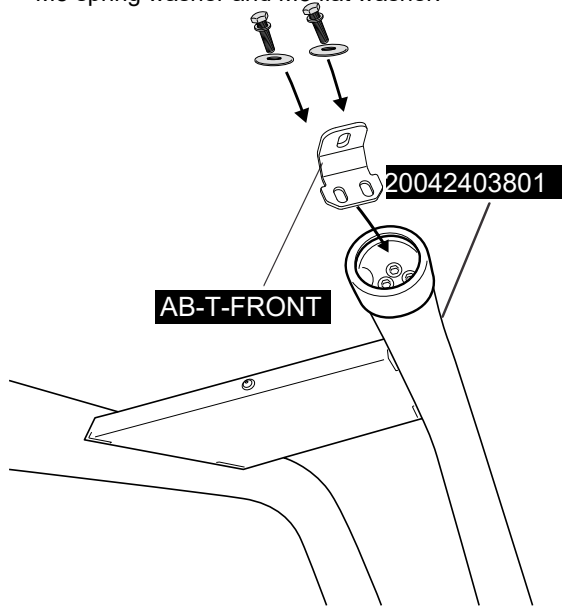

Repeat above steps to the other side.

1. Align part number 20042554201 (rear mount bracket (L)) as indicated.
2. Fasten in to position using M8 x 25mm hex bolt, M8 spring washer and M8 flat washer.

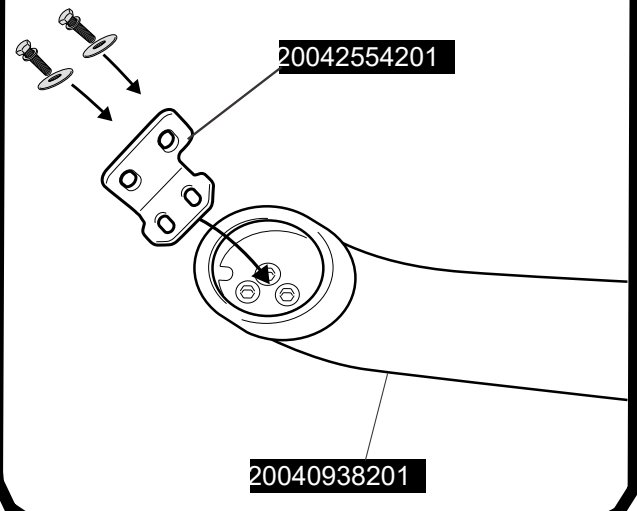

Repeat above steps to the other side. Using part number: 20042554301 (rear mount bracket (R))

Remove and retain the indicated M8 torx bolt located to the front of the tub.
Repeat to the other side.

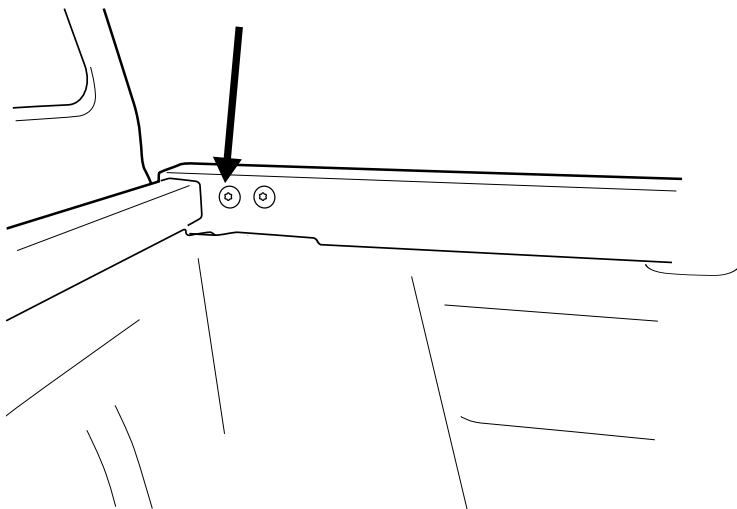

Place Armour bar on the tub rail.

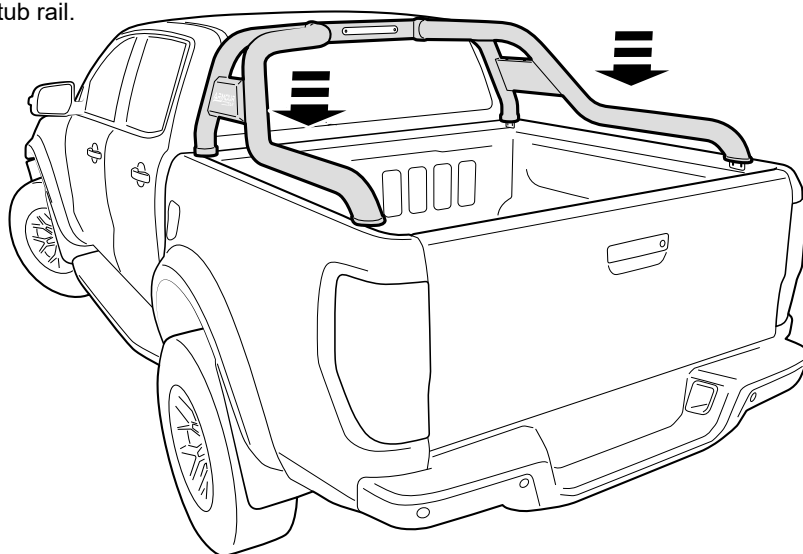

As indicated center the AB-T-FRONT bracket to the factory thread.

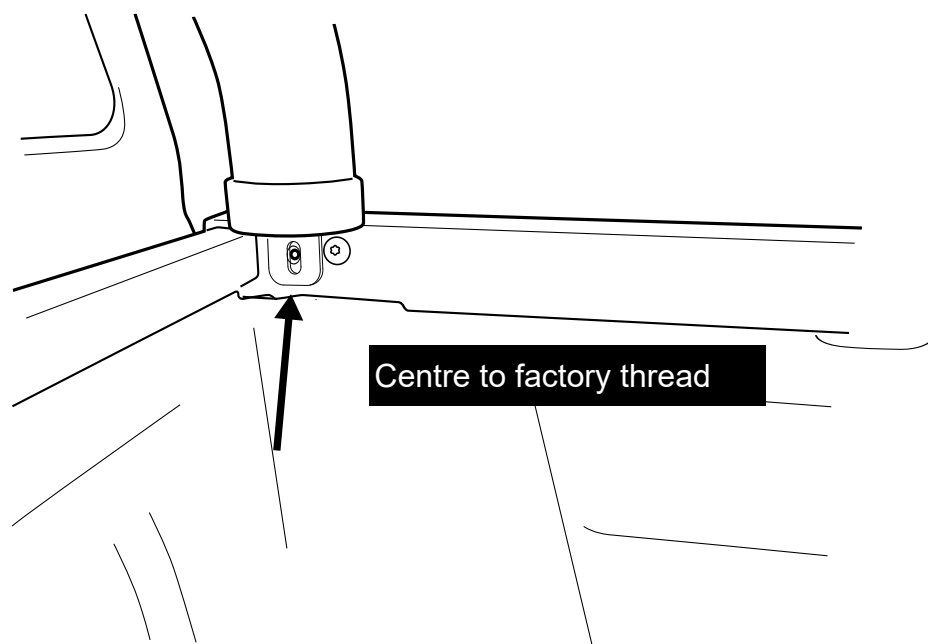

Repeat above steps to the other side.

Mark all points as indicated.

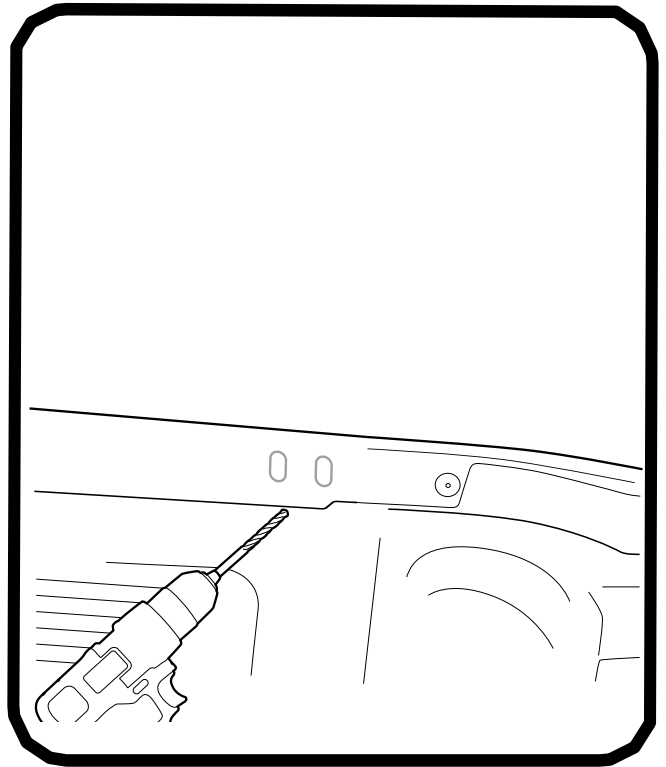
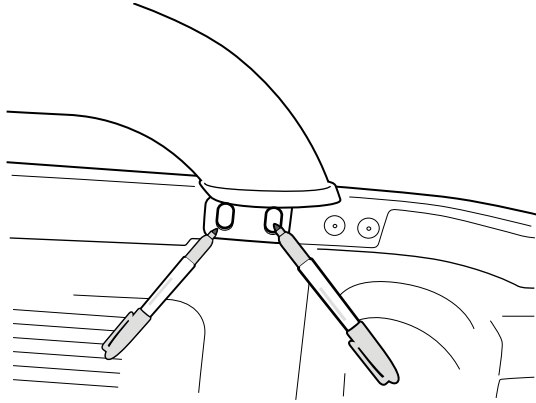

Repeat above steps to the other side.

Fasten into position using supplied M8 Hex flange bolt. Fasten to 10Nm torque.
Repeat to the otherside.

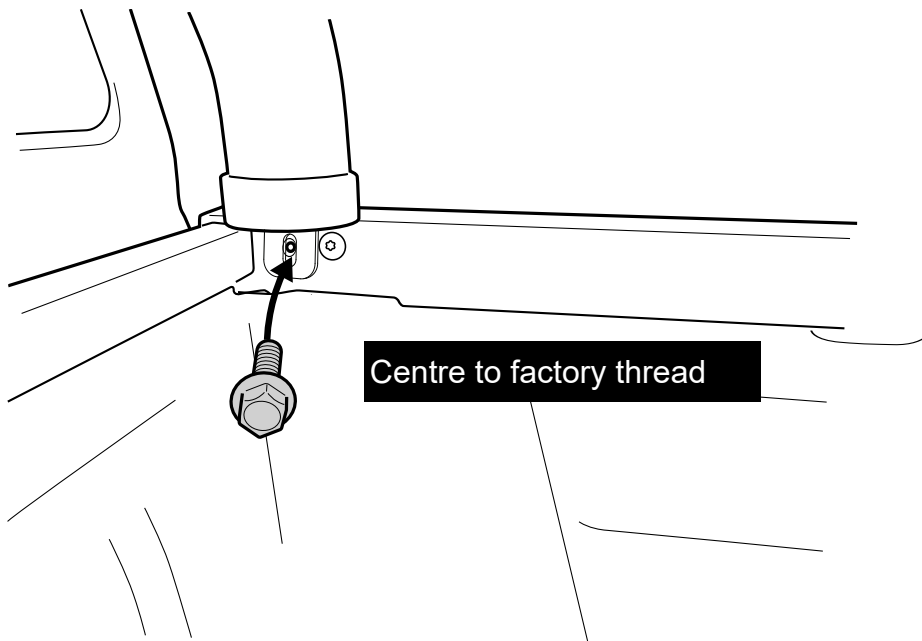

Feed M8 hex flange nut into the tub rail cavity behind the sports bar bracket hole.

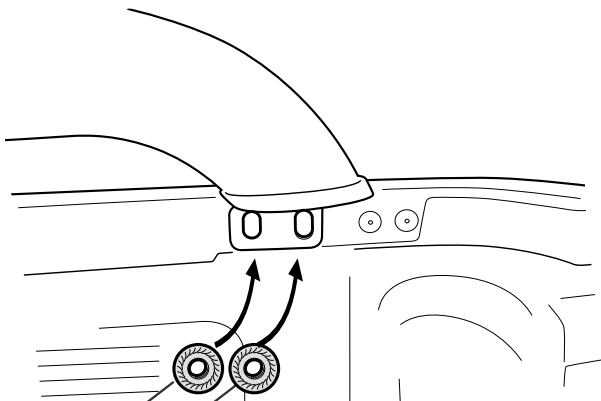

E3008183

Fasten into place by using M8 hex flange bolt.

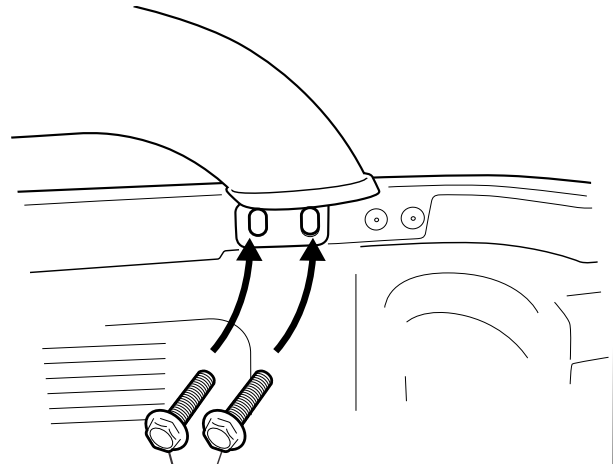

E3008097